



# 85mA Dual H-Bridge Odometer Driver with Buffered Speed Signal Output

## Description

The CS8442 is a stepper motor driver that implements an H-bridge design to drive two coils in an eight step sequence each revolution. Each H-bridge is capable of delivering 85mA to the load.

The sequencer function insures that the odometer is monotonic and that cross-conduction of each H bridges does not occur. Before the beginning of each sequence, both bridges are turned off. This "dead zone" minimizes the fly back energy generated in the inductive loads. In addition, on board clamp diodes across each output protect the output drive

transistors from excessive fly back voltages.

The CS8442 is fault protected against reverse battery, short circuit, and over voltage conditions. If a fault is detected, the IC shuts down.

The buffered speed signal output (SENSOR OUT) is an open collector NPN capable of driving a 4.7kΩ load connected to a 5V supply. The signal is a buffered, inverted version of the speed sensor input voltage (SENSOR IN). The input voltage can be either a sine or square wave form.

## Features

- Buffered Speed Sensor Output
- No Cross-conduction in either H-bridge
- Guaranteed Monotonic
- On Chip Flyback Diodes
- Fault Protection
  - Overvoltage
  - Short Circuit Protection
  - Load Dump Protection to 60V

## Absolute Maximum Ratings

Supply Voltage ( $V_{CC}$ ) (continuous) -40°C to +105°C .....	-0.5 to 24V
(100ms pulse transient) -40°C to +105°C .....	-0.5 to 60V
Input Voltage ( $V_{IN}$ ) .....	-0.3 to $V_{CC} + 0.3V$
Storage Temperature Range ( $T_{STG}$ ) .....	-65°C to +150°C
Junction Temperature .....	-40°C to +150°C
Speed Sensor Output .....	7V
ESD (Human Body Model) .....	2kV
Lead Temperature Soldering	
Wave Solder (through hole styles only) .....	10 sec. max, 260°C peak

## Block Diagram

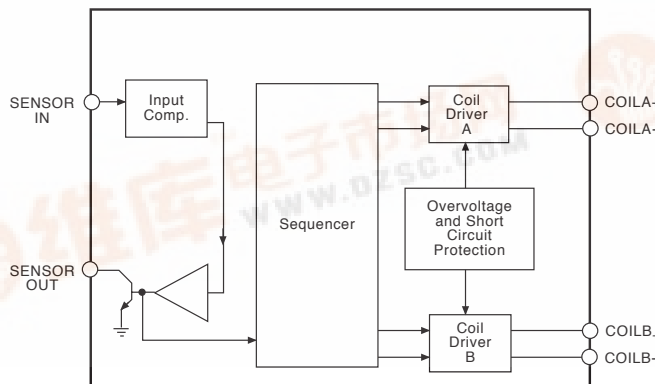

## Package Options

8L PDIP

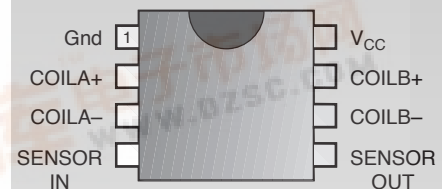

**Electrical Characteristics:** Unless otherwise stated, these specifications apply for -40°C to +105°C,  $V_{CC} = 6.5$  to 15.5 VDC. All voltage shall be referenced to Gnd unless otherwise noted. Overvoltage shutdown of coils occurs when  $V_{CC} > 16V$ .

PARAMETER	TEST CONDITIONS	MIN	TYP	MAX	UNIT
<b>■ Supply</b>					
Supply Voltage Range	$T_A = -40^\circ\text{C}$ to $+105^\circ\text{C}$	6.5		15.5	$\alpha$
	$T_A = -40^\circ\text{C}$ to $+25^\circ\text{C}$	6.5		24.0	$\alpha$
Supply Current	$V_{CC} = 15.5$ VDC Outputs not loaded			35	mA
Overvoltage Shutdown		16		23	V
<b>■ Speed Sensor</b>					
Input Frequency Range		0		400	Hz
Switching Threshold		1.6		3.0	VDC
Hysteresis		300			mV
Input Bias Current	$V_{IN} = 0.8$ VDC to $V_{CC}$			$\pm 1$	$\mu\text{A}$
Input Voltage Range		0		8	VDC
Operating Input Voltage	10K Ohm Resistor in Series			-15 to $V_{CC}$	VDC
Output Saturation Voltage	$I_{CC} = 1.3$ mA			0.4	V
Output Leakage	$V_{CC} = 5.5$ V			10	$\mu\text{A}$
Input Clamp Current	I Clamp at $V_{IN} = 0$ VDC		-0.4	-5.0	mA
<b>■ Coil Output Drivers</b>					
Coil Load	$+25^\circ\text{C}$	198	210	222	$\Omega$
Coil Inductance				80	mH
Coil Resistance Temperature Coefficient				0.39	$\% / ^\circ\text{C}$
* Energized Coil Voltage (Both Polarities) A and B	$V_{CC} = 6.5$ VDC $V_{CC} = 10.0$ VDC $V_{CC} = 15.5$ VDC, $T_A = -20^\circ\text{C}$ to $+105^\circ\text{C}$ $V_{CC} = 15.5$ VDC, $T_A = -40^\circ\text{C}$ to $-20^\circ\text{C}$	$V_{CC} - 1.50$ $V_{CC} - 1.60$ $V_{CC} - 1.75$ $V_{CC} - 2.00$			VDC VDC VDC VDC
De-Energized Coil Leakage Current				$\pm 100$	$\mu\text{A}$
<b>■ Short Circuit Protection</b>					
Short Circuit Threshold Coil A + Coil B			275	400	mA
Short Circuit Turn Off Delay			5		$\mu\text{s}$

\* Voltage across the coils shall be measured at the specific voltages, but shall also be within linearly interpolated limits.

Package Pin Description

PACKAGE PIN #	PIN SYMBOL	FUNCTION
<b>8L PDIP</b>		
1	Gnd	Ground connection.
2	COILA+	Output stage, when active, supplies current to COIL A.
3	COILA-	Output stage, when active, supplies current to COIL A.
4	SENSOR IN	Input signal from wheel speed or engine rpm.
5	SENSOR OUT	Buffered and inverted output of SENSOR IN signal.
6	COILB-	Output stage, when active, supplies current to COIL B.
7	COILB+	Output stage, when active, supplies current to COIL B.
8	V <sub>CC</sub>	Supply Voltage.

Application Information

Speed Sensor

SENSOR IN is a PNP comparator input that accepts a sine or square wave input. Signals in excess of V<sub>CC</sub> or Ground will not damage the input as long as the input current is limited to 1.5mA. An active clamp at 0V prevents negative input voltages from disrupting normal operation. The input can withstand 150 VDC as long as the input current does not exceed 1.5mA. This is possible if a 100kΩ resistor is placed in series with the SENSOR IN.

SENSOR OUT is an open collector NPN transistor that produces a buffered and inverted version of the SENSOR IN signal. It is capable of driving a 4.7kΩ load connected to a 5V supply.

Sequencer

The eight step sequencer moves the two H bridge output drivers through 8 sequential states (Table 1, Figure 1). In State 0, current flows from COILA+ out through COIL A and back in through COILA-. The same polarity also holds for COIL B. In State 1, COIL A outputs turn off while COIL B outputs continue conducting with the same polarity. In State 2, current flows from COIL A- out through the coil and back in COIL A+. COIL B outputs continue with their original polarity. COIL A outputs maintain this polarity through States 3 and 4 during which COIL B outputs are first turned off and then reversed. COIL B's reversed polarity continues in Stages 5 and 6. COIL A's outputs are turned off in Stage 5 and then turned back on (positive polarity) in Stage 6. In Stage 7, COIL B is off and COILA outputs continue with a positive polarity.

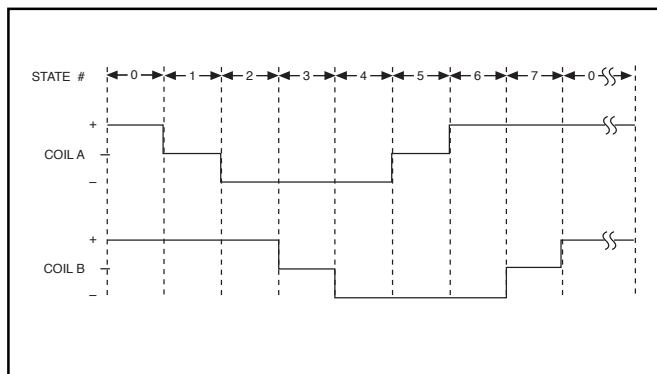

Figure 1: State Diagram for Coil Outputs

Table 1: Transition States

State	Coil A	Coil B
0	+	+
1	OFF	+
2	-	+
3	-	OFF
4	-	-
5	OFF	-
6	+	-
7	+	OFF

The polarity definition for the coil driver outputs is as follows:

Polarity	Connect Coil +	Connect Coil -
Positive (+)	V <sub>CC</sub>	Gnd
Negative (-)	Gnd	V <sub>CC</sub>

H Bridge Outputs A and B

Each H-bridge output stage consists of 4 power NPN transistors with fly back diodes (Figure 2). Each half bridge has a composite saturation voltage of 1.5V at V<sub>CC</sub>=15.5V and I<sub>OUT</sub>= 85mA.

The output stage is designed to prevent cross conduction: i.e., at no time can Q1 and Q2 or Q3 and Q4 conduct. This dead zone time minimizes fly back energy and helps protect the output stages from damage.

Protection Circuitry

The CS8442 is protected from short circuit, over voltage and thermal runaway conditions. When any of these faults is detected, an internal flip-flop is set and both H bridges are disabled. When the fault condition is removed, the Flip-Flop is reset after the first positive going edge from the speed sensor input.

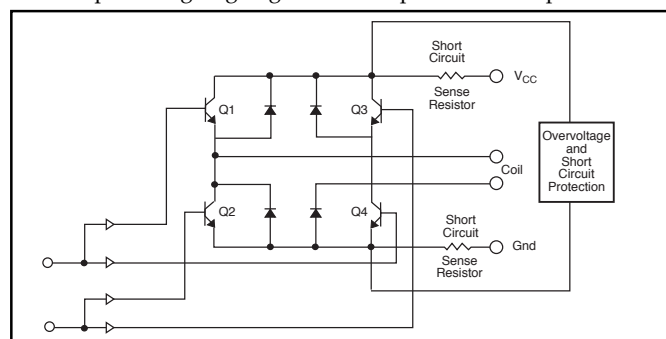
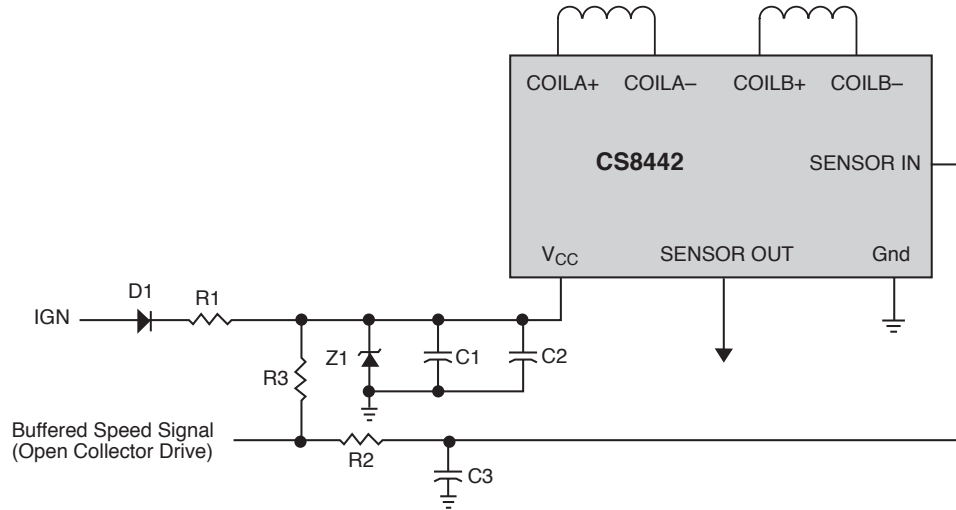

Figure 2: Coil Driver Output

**Application Diagram**

- C1 - 10 $\mu$ F
- C2 - 0.1 $\mu$ F
- C3 - 0.01 $\mu$ F
- R1 - 3.9 $\Omega$  0.5W
- R2 - 100k $\Omega$
- R3 - 15k $\Omega$
- D1 - 1A 600PIV
- Z1 - 50V 0.5W
- COIL A - 210 $\pm$ 12 $\Omega$ , 80mH
- COIL B - 210 $\pm$ 12 $\Omega$ , 80mH



**Package Specification**

**PACKAGE DIMENSIONS IN mm (INCHES)**

Lead Count	D			
	Metric		English	
	Max	Min	Max	Min
8L PDIP	10.16	9.02	.400	.355

**PACKAGE THERMAL DATA**

Thermal Data		8L PDIP	
R $\theta_{JC}$	typ	52	$^{\circ}$ C/W
R $\theta_{JA}$	typ	100	$^{\circ}$ C/W

**Plastic DIP (N); 300 mil wide**

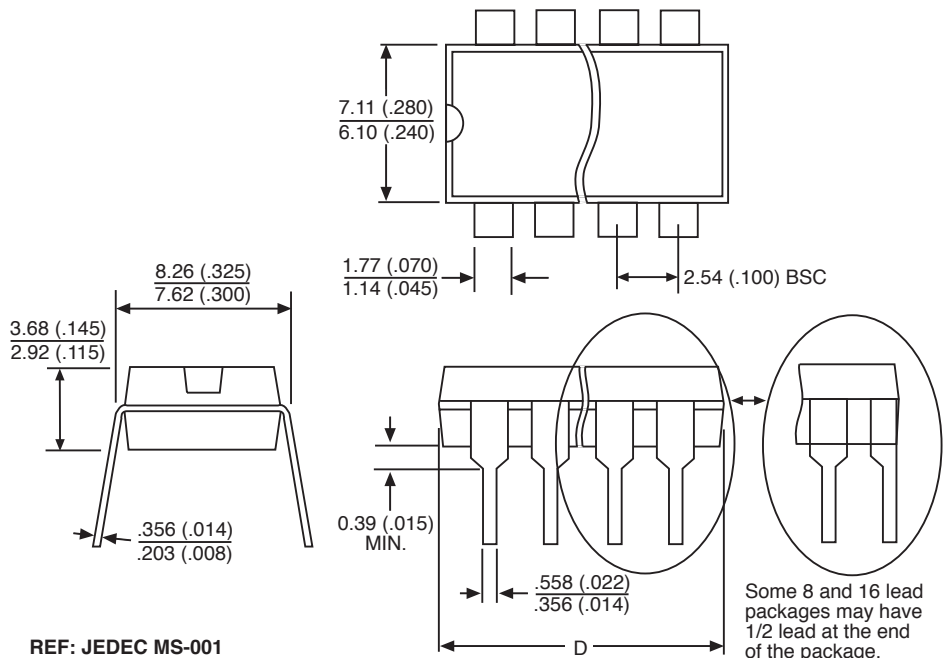

REF: JEDEC MS-001

**Ordering Information**

Part Number	Description
CS8442XN8	8L PDIP

Cherry Semiconductor Corporation reserves the right to make changes to the specifications without notice. Please contact Cherry Semiconductor Corporation for the latest available information.