

Universal High Brightness LED Driver

Features

- ▶ >90% Efficiency
- ▶ 8V to 450V input range
- ▶ Constant-current LED driver
- ▶ Applications from a few mA to more than 1A Output
- ▶ LED string from one to hundreds of diodes
- ▶ PWM Low-Frequency Dimming via Enable pin
- ▶ Input Voltage Surge ratings up to 450V

Applications

- ▶ DC/DC or AC/DC LED Driver applications
- ▶ RGB Backlighting LED Driver
- ▶ Back Lighting of Flat Panel Displays
- ▶ General purpose constant current source
- ▶ Signage and Decorative LED Lighting
- ▶ Automotive
- ▶ Chargers

General Description

The HV9910 is a PWM high-efficiency LED driver control IC. It allows efficient operation of High Brightness (HB) LEDs from voltage sources ranging from 8VDC up to 450VDC. The HV9910 controls an external MOSFET at fixed switching frequency up to 300kHz. The frequency can be programmed using a single resistor. The LED string is driven at constant current rather than constant voltage, thus providing constant light output and enhanced reliability. The output current can be programmed between a few milliamps and up to more than 1.0A.

HV9910 uses a rugged high voltage junction isolated process that can withstand an input voltage surge of up to 450V. Output current to an LED string can be programmed to any value between zero and its maximum value by applying an external control voltage at the linear dimming control input of the HV9910. The HV9910 provides a low-frequency PWM dimming input that can accept an external control signal with a duty ratio of 0-100% and a frequency of up to a few kilohertz.

Typical Application

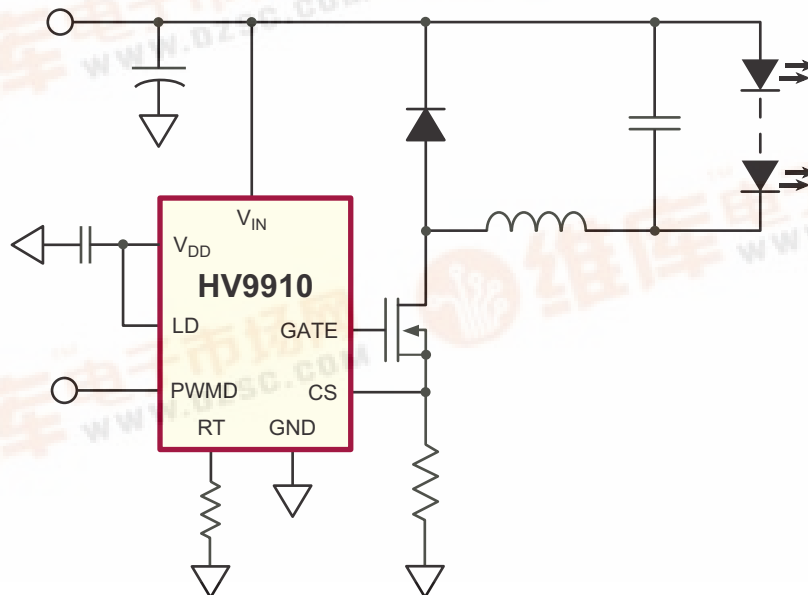

Ordering Information

Device	Package Options		
	SOIC-16	DIP-8	SOIC-8
HV9910	HV9910NG-G	HV9910P-G	HV9910LG-G

-G indicates package is RoHS compliant ('Green')



Absolute Maximum Ratings

Parameter	Value
V_{IN} to GND	-0.5V to +470V
CS	-0.3V to ($V_{DD} + 0.3V$)
LD, PWM_D to GND	-0.3V to ($V_{DD} - 0.3V$)
GATE to GND	-0.3V to ($V_{DD} + 0.3V$)
V_{DDMAX}	13.5V
Continuous Power Dissipation ($T_A = +25^\circ C$) (Note 1)	
16-Pin SO (derate 7.5mW/ $^\circ C$ above +25 $^\circ C$)	750mW
8-Pin DIP (derate 9mW/ $^\circ C$ above +25 $^\circ C$)	900mW
8-Pin SO (derate 6.3mW/ $^\circ C$ above +25 $^\circ C$)	630mW
Operating Temperature Range	-40 $^\circ C$ to +85 $^\circ C$
Junction Temperature	+125 $^\circ C$
Storage Temperature Range	-65 $^\circ C$ to +150 $^\circ C$

Absolute Maximum Ratings are those values beyond which damage to the device may occur. Functional operation under these conditions is not implied. Continuous operation of the device at the absolute rating level may affect device reliability. All voltages are referenced to device ground.

Electrical Characteristics

(Over recommended operating conditions unless otherwise specified - $T_A = 25^\circ C$)

Symbol	Parameter	Min	Typ	Max	Units	Conditions
V_{INDC}	Input DC supply voltage range	8.0		450	V	DC input voltage
I_{INsd}	Shut-Down mode supply current	-	0.5	1	mA	Pin PWM_D to GND, $V_{IN} = 8V$
V_{DD}	Internally regulated voltage	7.0	7.5	8.0	V	$V_{IN} = 8 - 450V$, $I_{DD(ext)} = 0$, pin Gate open
V_{DDmax}	Maximal pin V_{DD} voltage	-	-	13.5	V	When an external voltage applied to pin V_{DD}
$I_{DD(ext)}$	V_{DD} current available for external circuitry ¹	-	-	1.0	mA	$V_{IN} = 8 - 100V$
UVLO	V_{DD} undervoltage lockout threshold	6.45	6.7	6.95	V	V_{IN} rising
$\Delta UVLO$	V_{DD} undervoltage lockout hysteresis	-	500	-	mV	V_{IN} falling
$V_{EN(lo)}$	Pin PWM_D input low voltage	-	-	1.0	V	$V_{IN} = 8 - 450V$
$V_{EN(hi)}$	Pin PWM_D input high voltage	2.4	-	-	V	$V_{IN} = 8 - 450V$
R_{EN}	Pin PWM_D pull-down resistance	50	100	150	k Ω	$V_{EN} = 5V$
$V_{CS(hi)}$	Current sense pull-in threshold voltage	225	250	275	mV	@ $T_A = -40^\circ C$ to +85 $^\circ C$
$V_{GATE(hi)}$	GATE high output voltage	$V_{DD} - 0.3$	-	V_{DD}	V	$I_{OUT} = 10mA$
$V_{GATE(lo)}$	GATE low output voltage	0	-	0.3	V	$I_{OUT} = -10mA$
f_{OSC}	Oscillator frequency	20 80	25 100	30 120	kHz kHz	$R_{OSC} = 1.00M\Omega$ $R_{OSC} = 226k\Omega$
D_{MAXhf}	Maximum PWM Duty Cycle	-	-	100	%	$F_{PWMhf} = 25kHz$, at GATE, CS to GND.
V_{LD}	Linear Dimming pin voltage range	0	-	250	mV	@ $T_A < 85^\circ C$, $V_{IN} = 12V$
T_{BLANK}	Current sense blanking interval	150	215	280	ns	$V_{CS} = 0.55V_{LD}$, $V_{LD} = V_{DD}$

¹ Also limited by package power dissipation limit, whichever is lower.



Symbol	Parameter	Min	Typ	Max	Units	Conditions
t_{DELAY}	Delay from CS trip to GATE lo	-	-	300	ns	$V_{\text{IN}} = 12\text{V}$, $V_{\text{LD}} = 0.15$, $V_{\text{CS}} = 0$ to 0.22V after T_{BLANK}
t_{RISE}	GATE output rise time	-	30	50	ns	$C_{\text{GATE}} = 500\text{pF}$
t_{FALL}	GATE output fall time	-	30	50	ns	$C_{\text{GATE}} = 500\text{pF}$

Pinout

Pin	SOIC-16	SOIC-8 DIP-8	Description
V_{IN}	1	1	Input voltage 8V to 450V DC
CS	4	2	Senses LED string current
GND	5	3	Device ground
GATE	8	4	Drives the gate of the external MOSFET
PWM_D	9	5	Low Frequency PWM Dimming pin, also Enable input. Internal 100k Ω pull-down to GND
V_{DD}	12	6	Internally regulated supply voltage (7.5V nominal). Can supply up to 1mA for external circuitry. A sufficient storage capacitor is used to provide storage when the rectified AC input is near the zero crossings.
LD	13	7	Linear dimming by changing the current limit threshold at current sense comparator
R_{OSC}	14	8	Oscillator control. A resistor connected between this pin and ground sets the PWM frequency.

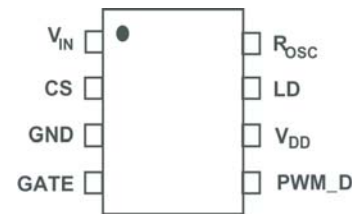

8-Lead DIP/SOIC

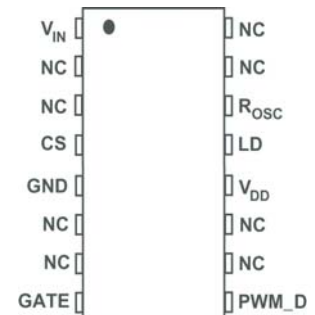

16-Lead SOIC

No Connects (NC) are not internally connected and may be used for pass-thru PCB traces.

Block Diagram & Typical Applications

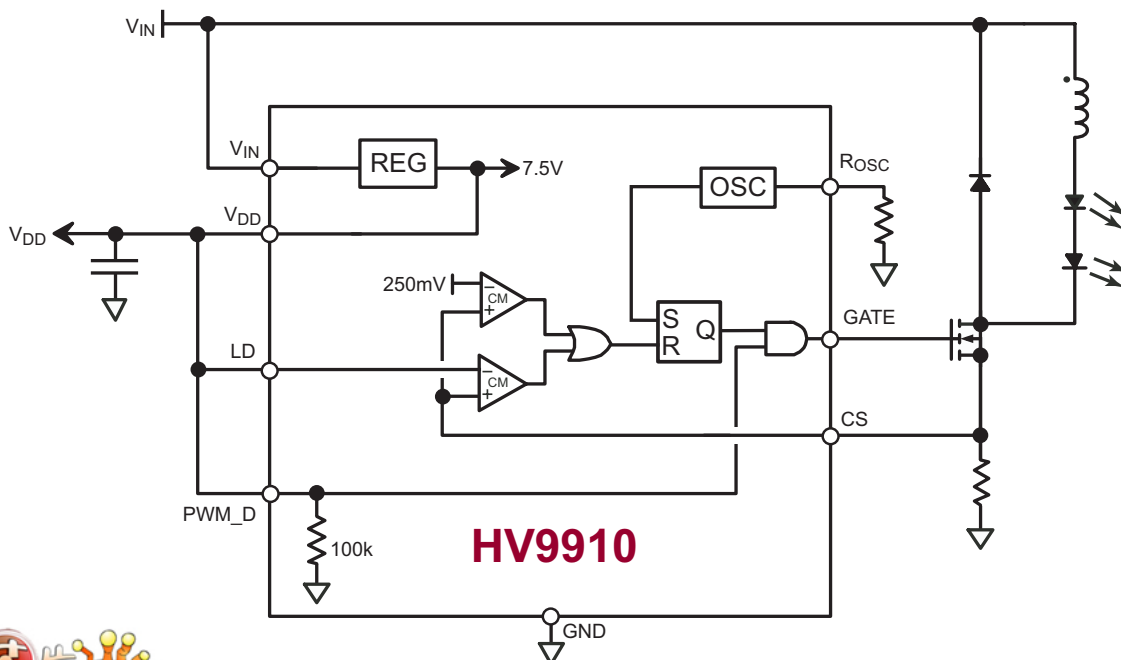

Application Information

AC/DC Off-Line Applications

The HV9910 is a low-cost off-line buck, boost or buck-boost converter control IC specifically designed for driving multi-LED strings or arrays. It can be operated from either universal AC line or any DC voltage between 8-450V. Optionally, a passive power factor correction circuit can be used in order to pass the AC harmonic limits set by EN 61000-3-2 Class C for lighting equipment having input power less than 25W. The HV9910 can drive up to hundreds of High-Brightness (HB) LEDs or multiple strings of HB LEDs. The LED arrays can be configured as a series or series/parallel connection. The HV9910 regulates constant current that ensures controlled brightness and spectrum of the LEDs, and extends their lifetime. The HV9910 features an enable pin (PWM_D) that allows PWM control of brightness.

The HV9910 can also control brightness of LEDs by programming continuous output current of the LED driver (so-called linear dimming) when a control voltage is applied to the LD pin.

The HV9910 is offered in standard 8-pin SOIC and DIP packages. It is also available in a high voltage rated SO-16 package for applications that require V_{IN} greater than 250V.

The HV9910 includes an internal high-voltage linear regulator that powers all internal circuits and can also serve as a bias supply for low voltage external circuitry.

LED Driver Operation

The HV9910 can control all basic types of converters, isolated or non-isolated, operating in continuous or discontinuous conduction mode. When the gate signal enhances the external power MOSFET, the LED driver stores the input energy in an inductor or in the primary inductance of a transformer and, depending on the converter type, may partially deliver the energy directly to LEDs. The energy stored in the magnetic component is further delivered to the output during the off-cycle of the power MOSFET producing current through the string of LEDs (Flyback mode of operation).

When the voltage at the V_{DD} pin exceeds the UVLO threshold the gate drive is enabled. The output current is controlled by means of limiting peak current in the external power MOSFET. A current sense resistor is connected in series with the source terminal of the MOSFET. The voltage from the sense resistor is applied to the CS pin of the HV9910. When the voltage at CS pin exceeds a peak current sense voltage threshold, the gate drive signal terminates, and the power MOSFET turns off. The threshold is internally set to 250mV, or it can be programmed externally by applying voltage to the LD pin. When soft start is required, a capacitor can be connected to the LD pin to allow this voltage to ramp

at a desired rate, therefore, assuring that output current of the LED ramps gradually.

Optionally, a simple passive power factor correction circuit, consisting of 3 diodes and 2 capacitors, can be added as shown in the application circuit diagram of Figure 1.

Supply Current

A current of 1mA is needed to start the HV9910. As shown in block diagram, this current is internally generated in HV9910 without using bulky startup resistors typically required in the offline applications. Moreover, in many applications the HV9910 can be continuously powered using its internal linear regulator that provides a regulated voltage of 7.5V for all internal circuits.

Setting Light Output

When the buck converter topology of Figure 1 is selected, the peak CS voltage is a good representation of the average current in the LED. However, there is a certain error associated with this current sensing method that needs to be accounted for. This error is introduced by the difference between the peak and the average current in the inductor. For example if the peak-to-peak ripple current in the inductor is 150mA, to get a 500mA LED current, the sense resistor should be $250\text{mV}/(500\text{mA} + 0.5 \cdot 150\text{mA}) = 0.43\Omega$.

Dimming

Dimming can be accomplished in two ways, separately or combined, depending on the application. Light output of the LED can be controlled either by linear change of its current, or by switching the current on and off while maintaining it constant. The second dimming method (so-called PWM dimming) controls the LED brightness by varying the duty ratio of the output current.

The linear dimming can be implemented by applying a control voltage from 0 to 250mV to the LD pin. This control voltage overrides the internally set 250mV threshold level of the CS pin and programs the output current accordingly. For example, a potentiometer connected between V_{DD} and ground can program the control voltage at the CS pin. Applying a control voltage higher than 250mV will not change the output current setting. When higher current is desired, select a smaller sense resistor.

The PWM dimming scheme can be implemented by applying an external PWM signal to the PWM_D pin. The PWM signal can be generated by a microcontroller or a pulse generator with a duty cycle proportional to the amount of desired light output. This signal enables and disables the converter modulating the LED current in the PWM fashion. In this mode, LED current can be in one of the two states: zero or



the nominal current set by the current sense resistor. It is not possible to use this method to achieve average brightness levels higher than the one set by the current sense threshold level of the HV9910. By using the PWM control method of the HV9910, the light output can be adjusted between zero and 100%. The accuracy of the PWM dimming method is limited only by the minimum gate pulse width, which is a fraction of a percent of the low frequency duty cycle.

Some of the typical waveforms illustrating the PWM dimming method used with the application circuit of Figure 1 are given below. CH₁ shows the MOSFET Drain voltage, CH₂ is the PWM signal to pin PWM_D and CH₄ is the current in the LED string.

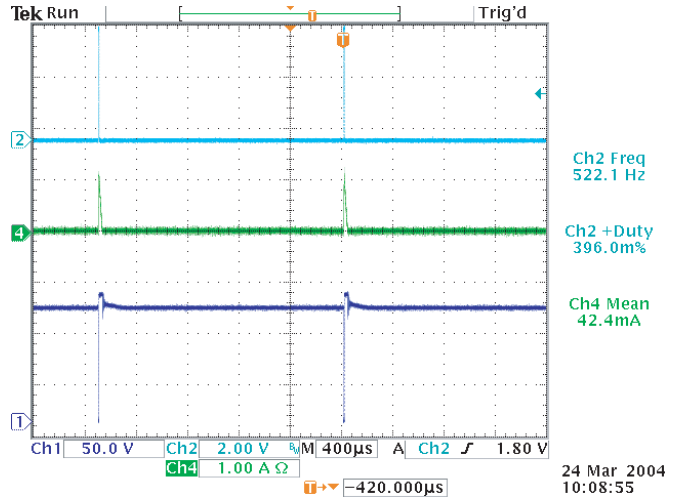

0.4% PWM Ratio at 500Hz Dimming

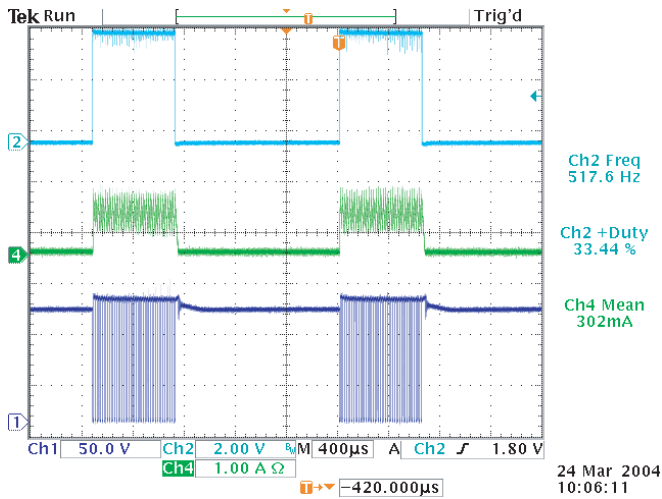

33% PWM Ratio at 500Hz Dimming

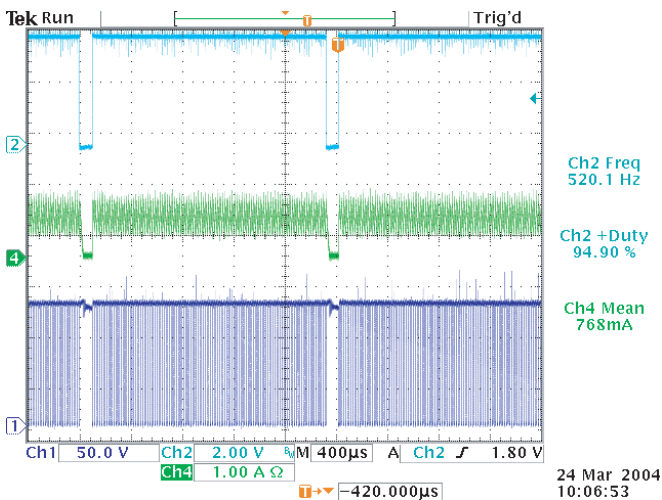

95% PWM Ratio at 500Hz Dimming

Programming Operating Frequency

The operating frequency of the oscillator is programmed between 25 and 300kHz using an external resistor connected to the R_{OSC} pin:

$$F_{OSC} = 25000 / (R_{OSC} [k\Omega] + 22) [kHz]$$

Power Factor Correction

When the input power to the LED driver does not exceed 25W, a simple passive power factor correction circuit can be added to the HV9910 application circuit of Figure 1 in order to pass the AC line harmonic limits of the EN61000-3-2 standard for Class C equipment. The typical application circuit diagram shows how this can be done without affecting the rest of the circuit significantly. A simple circuit consisting of 3 diodes and 2 capacitors is added across the rectified AC line input to improve the line current harmonic distortion and to achieve a power factor greater than 0.85.

Inductor Design

Referring to the Typical Application Circuit below the value can be calculated from the desired peak-to-peak LED ripple current in the inductor. Typically, such ripple current is selected to be 30% of the nominal LED current. In the example given here, the nominal current I_{LED} is 350mA.

The next step is determining the total voltage drop across the LED string. For example, when the string consists of 10 High-Brightness LEDs and each diode has a forward voltage drop of 3.0V at its nominal current; the total LED voltage V_{LEDS} is 30V.



HV9910

Knowing the nominal rectified input voltage $V_{IN} = 120V \cdot 1.41 = 169V$, the switching duty ratio can be determined, as:

$$D = V_{LEDs} / V_{IN} = 30/169 = 0.177$$

Then, given the switching frequency, in this example $f_{OSC} = 50KHz$, the required on-time of the MOSFET transistor can be calculated:

$$T_{ON} = D/f_{OSC} = 3.5 \text{ microsecond}$$

The required value of the inductor is given by:

$$L = (V_{IN} - V_{LEDs}) \cdot T_{ON} / (0.3 \cdot I_{LED}) = 4.6mH$$

Input Bulk Capacitor

An input filter capacitor should be designed to hold the rectified AC voltage above twice the LED string voltage throughout the AC line cycle. Assuming 15% relative voltage ripple across the capacitor, a simplified formula for the minimum value of the bulk input capacitor is given by:

$$C_{MIN} = I_{LED} \cdot V_{LEDs} \cdot 0.06 / V_{IN}^2$$

$C_{MIN} = 22 \mu F$, a value $22\mu F/250V$ can be used.

A passive PFC circuit at the input requires using two series connected capacitors at the place of calculated C_{MIN} . Each of these identical capacitors should be rated for $1/2$ of the input voltage and have twice as much capacitance.

Enable

The HV9910 can be turned off by pulling the PWM_D pin to ground. When disabled, the HV9910 draws quiescent current of less than 1mA.

Output Open Circuit Protection

When the buck topology is used, and the LED is connected in series with the inductor, there is no need for any protection

against an open circuit condition in the LED string. Open LED connection means no switching and can be continuous. However, in the case of the buck-boost or the Flyback topology the HV9910 may cause excessive voltage stress of the switching transistor and the rectifier diode and potential failure. In this case, the HV9910 can be disabled by pulling the PWM_D pin to ground when the over voltage condition is detected.

DC/DC Low Voltage Applications

Buck Converter Operation

The buck power conversion topology can be used when the LED string voltage is needed to be lower than the input supply voltage. The design procedure for a buck LED driver outlined in the previous chapters can be applied to the low voltage LED drivers as well. However, the designer must keep in mind that the input voltage must be maintained higher than 2 times the forward voltage drop across the LEDs. This limitation is related to the output current instability that may develop when the HV9910 buck converter operates at a duty cycle greater than 0.5. This instability reveals itself as an oscillation of the output current at a sub-harmonic of the switching frequency.

Flyback (Buck-Boost) Operation

This power conversion topology can be used when the forward voltage drop of the LED string is higher, equal or lower than the input supply voltage. For example, the buck-boost topology can be appropriate when input voltage is supplied by an automotive battery (12V) and output string consists of three to six HB LEDs, as the case may be for tail and break signal lights.

In the buck-boost converter, the energy from the input source is first stored in the inductor or a Flyback transformer when

Figure 1: Typical Application Circuit

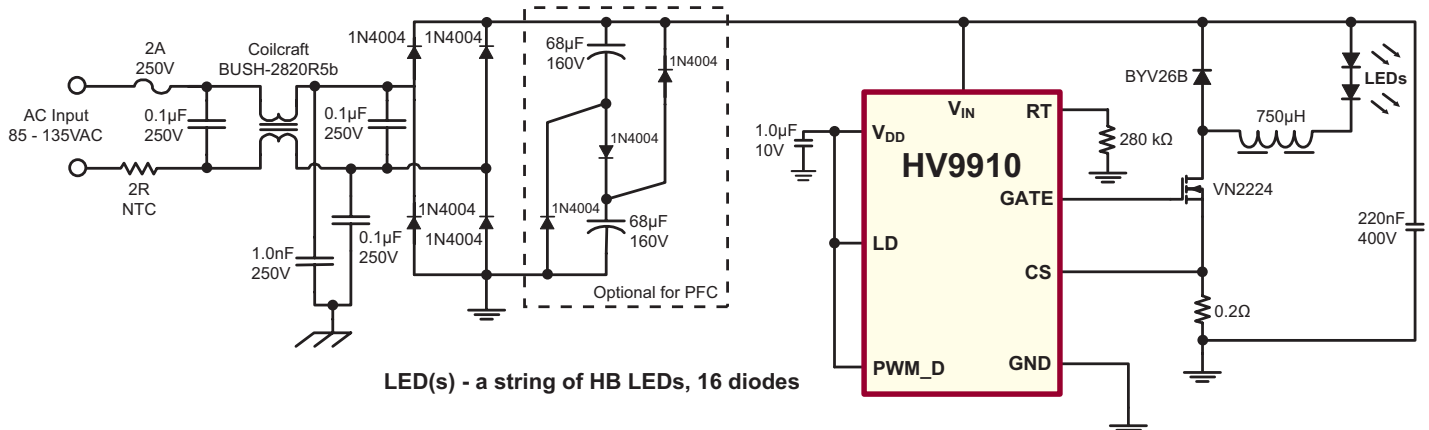

the switching transistor is ON. The energy is then delivered to the output during the OFF time of the transistor. When the energy stored in the Flyback inductor is not fully depleted by the next switching cycle (continuous conduction mode) the DC conversion between input and output voltage is given by:

$$V_{OUT} = -V_{IN} * D / (1 - D)$$

The output voltage can be either higher or lower than the input voltage, depending on duty ratio.

Let us discuss the above example of an automotive LED driver that needs to drive three HB LEDs at 350mA.

Knowing the nominal input voltage $V_{IN} = 12V$, the nominal duty ratio can be determined, as $D = V_{LEDs} / (V_{IN} + V_{LEDs}) = 9 / (12 + 9) = 0.43$

Then, given the switching frequency, in this example $f_{OSC} = 50KHz$, the required on-time of the MOSFET transistor can be calculated:

$$T_{ON} = D / f_{OSC} = 8.6 \text{ microsecond}$$

The required value of the inductor is given by:

$$L = V_{IN} * T_{ON} / (0.3 * I_{LED}) = 0.98mH, \text{ use } 1mH$$

Output Capacitor

Unlike the buck topology, the buck-boost converter requires an output filter capacitor to deliver power to the LED string during the ON time of switching the transistor, when the Flyback inductor current is diverted from the output of the converter.

In order to average the current in the LED, this capacitor must present impedance to the switching output AC ripple current that is much lower than the dynamic impedance R_{OUT} of the LED string. If we assume $R_{OUT} = 3.0\Omega$ in our example, in order to attenuate the switching ripple by a factor of 10, a capacitor with equivalent series resistance (ESR) of 0.3Ω is needed. A chip SMT tantalum capacitor can be selected for this purpose.



Figure 2: HV9910 Buck driver for a simple 900mA HB LED ($V_{IN} = 8 - 30V$)

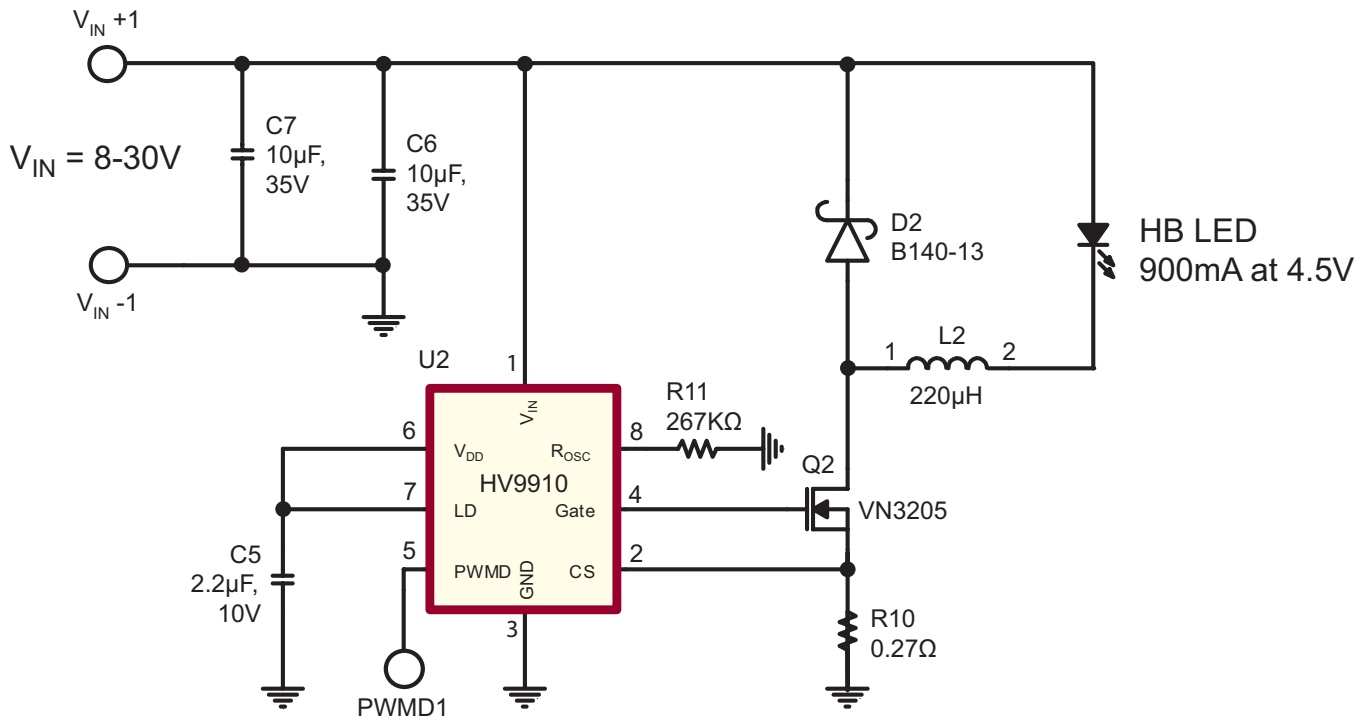
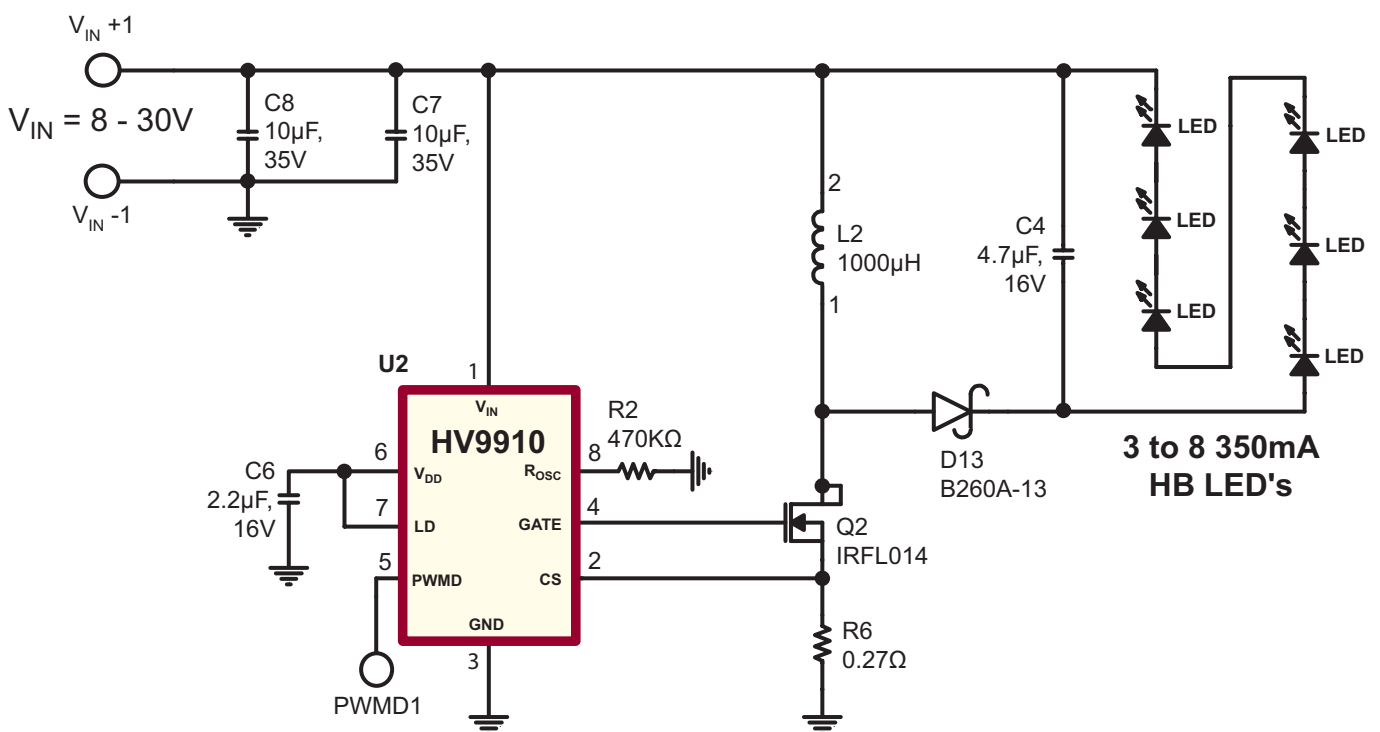
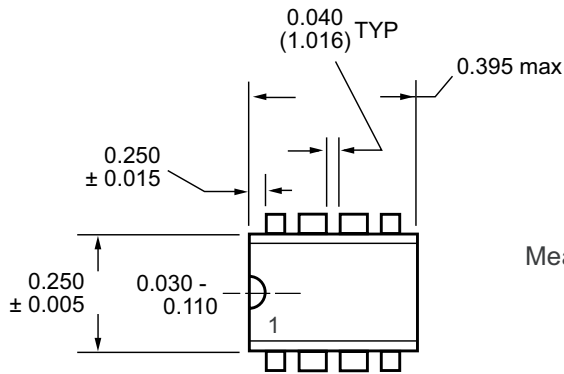

Figure 3: HV9910 Buck-Boost driver powering 3 to 8, 350mA HB LEDs ($V_{IN} = 8 - 30V$)



8-Lead Plastic Dual Inline (P) Package Outline



Measurement Legend = $\frac{\text{Dimensions in Inches}}{\text{(Dimensions in Millimeters)}}$

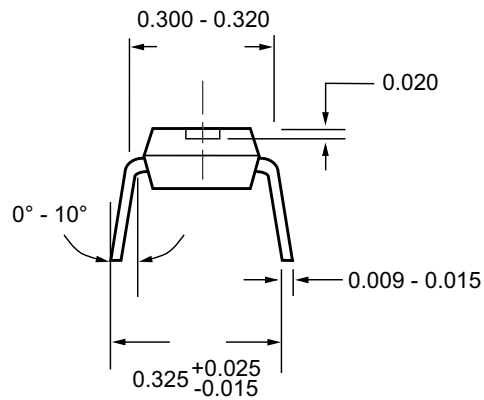
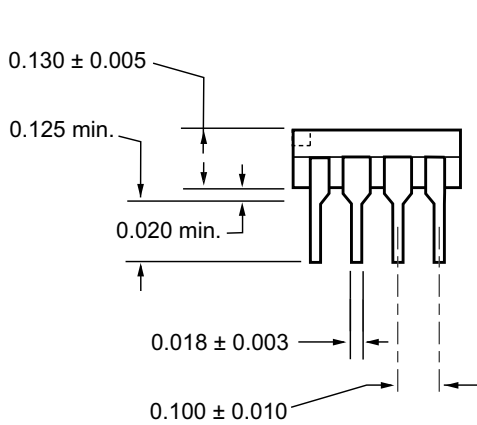

8-Lead SOIC (LG) Package Outline

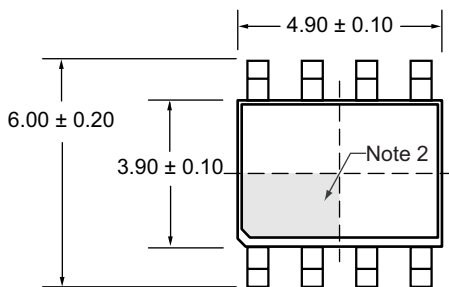

Top View

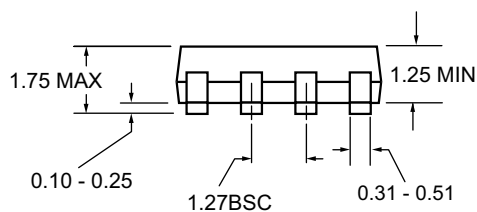

Side View

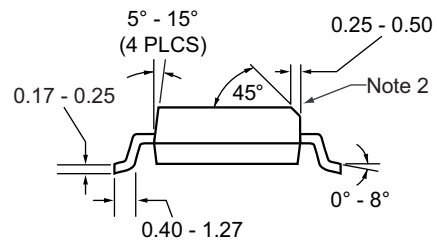

End View

Notes:

1. All dimensions in millimeters. Angles in degrees.
2. If the corner is not chamfered, then a Pin 1 identifier must be located within the area indicated.



16-Lead SOIC (NG) Package Outline

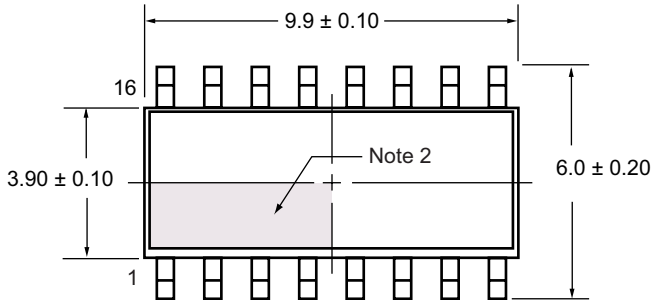

Top View

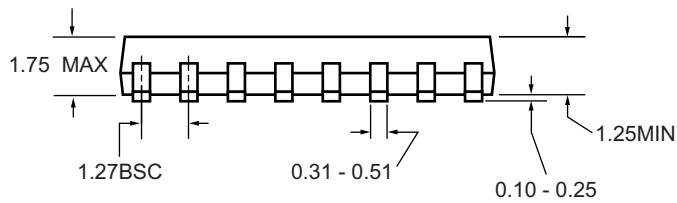

Side View

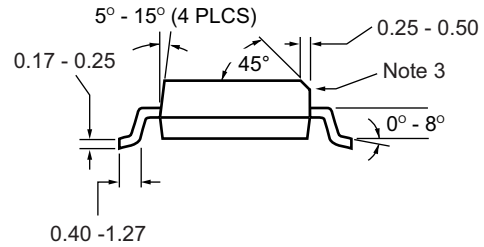

End View

Notes:

1. All dimensions in millimeters; angles in degrees
2. Pin 1 identifier must be located within the indicated area
3. Corner shape may differ from drawing

Supertex inc. does not recommend the use of its products in life support applications, and will not knowingly sell its products for use in such applications, unless it receives an adequate "product liability indemnification insurance agreement". **Supertex** does not assume responsibility for use of devices described and limits its liability to the replacement of the devices determined defective due to workmanship. No responsibility is assumed for possible omissions or inaccuracies. Circuitry and specifications are subject to change without notice. For the latest product specifications, refer to the **Supertex** website: <http://www.supertex.com>.