



# CH7017/CH7018

## CH7017/CH7018 TV Encoder / LVDS Transmitter

### Features

#### TV-Out:

- VGA to TV conversion supporting up to 1024x768 pixels.
- Macrovision™ 7.1.L1 copy protection support (CH7017 only, CH7018 is non-Macrovision™ version).
- Two variable-voltage digital input ports.
- Simultaneous LVDS and TV output.
- True scale rendering engine supporting under-scan in all TV output resolutions. †¥
- Enhanced text sharpness and adaptive flicker removal with up to 7 lines of filtering. ¥
- Support for NTSC and PAL TV formats.
- Outputs CVBS, S-Video, RGB and YPrPb.
- Support for SCART output.
- TV / Monitor connection detect.
- Output video switch for easy wiring to connectors.

#### LVDS-Out:

- Single / Dual LVDS transmitter.
  - Dual LVDS supporting pixel rates up to 330Mpixels/sec when both 12-bit input ports are ganged together.
  - Panel fitting scaler – up scale to 1600x1200 pixels.
  - LVDS low jitter PLL accepting EMI reduction input.
  - LVDS 18-bit and 24-bit outputs.
  - 2D dither engine.
  - Panel protection and Power-Down sequencing.
  - Programmable power management.
- Support for second CRT DAC bypass mode.
  - Four 10-bit video DAC outputs.
  - Fully programmable through serial port.
  - Complete Windows and DOS driver support.
  - Variable voltage interface to graphics device.
  - 128-pin LQFP package.

### 1.0 General Description

The CH7017/CH7018 is a Display Controller device that accepts two digital graphics input data streams. One data stream outputs through an LVDS transmitter to a LCD panel, while the other data stream is encoded for NTSC or PAL TV and outputs through four 10-bit high-speed DACs. The TV encoder device encodes a graphics signal up to 1024x768 resolution and outputs the video signals according to NTSC or PAL standards. The LVDS transmitter operates at pixel speeds up to 165MHz per link, supporting 1600x1200 panels at 60Hz refresh rate.

The device can also accept one graphics data stream over two 12-bit wide variable voltage ports which support nine different data formats including RGB and YCrCb (RGB must be used for LVDS output). A maximum of 330M pixels per second can be output through dual LVDS links.

The TV-Out processor will perform non-interlaced to interlaced conversion with scaling, flicker filtering, and encoding into any of the NTSC or PAL video standards. The scaler and flicker filter are adaptive and programmable for superior text display. Eight graphics resolutions are supported up to 1024 by 768 pixels with full vertical and horizontal under-scan capability in all modes. A high accuracy low jitter phase locked loop is integrated to create outstanding video quality. Anti-copy protection support is provided by Macrovision™ technology (CH7017 only). In addition to TV encoder modes, bypass modes are included which allow the TV DACs to be used as a second CRT DAC.

The LVDS transmitter includes a panel fitting up-scaler and a programmable dither function for the support of 18-bit panels. Data is encoded into commonly used formats, including those detailed in the OpenLDI and the SPWG specifications. Serialized data outputs on three to eight differential channels.

† Patent number 5,781,241  
 ¥ Patent number 5,914,753

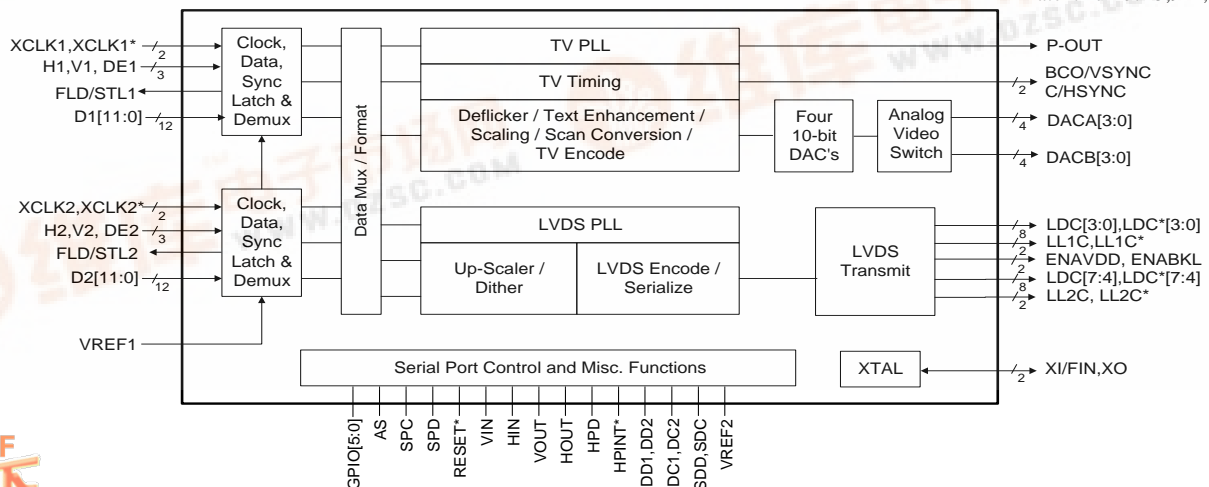

Figure 1: CH7017/CH7018 Functional Block Diagram



2.0 Pin Assignment

2.1 Package Diagram

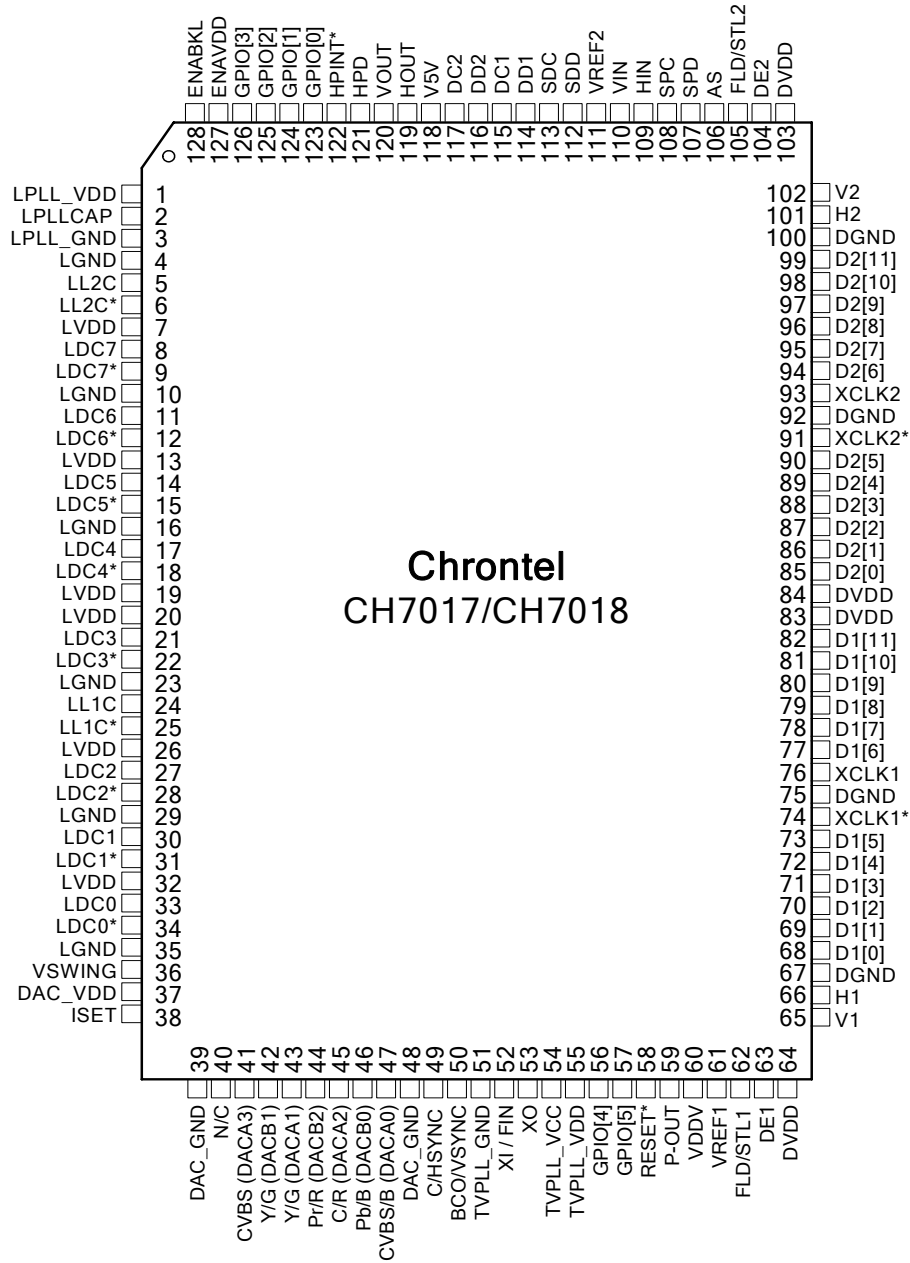

Figure 2: CH7017/CH7018 128 Pin LQFP Package (Top View)



**2.2 Pin Description**

**Table 1: Pin Description**

Pin #	# of Pins	Type	Symbol	Description
66, 101	2	In/Out	H1, H2	<b>Horizontal Sync Input / Output</b> When the SYO control bit is low, these pins accept a horizontal sync inputs for use with the input data. The amplitude will range from 0 to VDDV. VREF1 is the threshold level for these inputs. These pins must be used as inputs in RGB Bypass mode.  When the SYO control bit is high, the TV encoder will output a 64-pixels wide horizontal sync pulse from one of these pins. The output is driven from the DVDD supply, and it is valid ONLY when TV-Out is in operation.
65, 102	2	In/Out	V1, V2	<b>Vertical Sync Input / Output</b> When the SYO control bit is low, these pins accept a vertical sync inputs for use with the input data. The amplitude will range from 0 to VDDV. VREF1 is the threshold level for these inputs. These pins must be used as inputs in RGB Bypass mode.  When the SYO control bit is high, the TV encoder will output a 1-line wide vertical sync pulse from one of these pins. The output is driven from the DVDD supply, and it is valid ONLY when TV-Out is in operation.
63, 104	2	In	DE1, DE2	<b>Data Enable</b> These pins accept a data enable signal that is high when active video data is input to the device, and remains low during all other times. The amplitude will range from 0 to VDDV. VREF1 is the threshold level for these inputs. The TV-Out function uses H and V sync signals and values in the SAV Register as reference to active video.
62, 105	2	Out	FLD/STL1, FLD/STL2	<b>TV Field / Flat Panel Stall Signal</b> These outputs can be programmed to be either a TV Field output from the TV encoder, or a Stall output from the flat panel Up-scaler. These outputs are tri-stated upon power up.
107	1	In/Out	SPD	<b>Serial Port Data Input / Output</b> This pin functions as the bi-directional data pin of the serial port. It can operate with input levels from VDDV to DVDD. Outputs are driven from 0 to VREF2.
108	1	In	SPC	<b>Serial Port Clock Input</b> This pin functions as the clock input of the serial port. It can operate with input levels from VDDV to DVDD.
106	1	In	AS	<b>Address Select (Internal Pull-up)</b> This pin determines the device address of the serial port.
112	1	In/Out	SDD	<b>Low-Voltage DDC Serial Data</b> Low-voltage serial data for DDC. It uses VREF2 / 2 as the threshold voltage. VREF2 divide by 2 function is generated on-chip.
113	1	In/Out	SDC	<b>Low-Voltage DDC Serial Clock</b> Low-voltage serial clock for DDC. It uses VREF2 / 2 as the threshold voltage. VREF2 divide by 2 function is generated on-chip.
114, 116	2	In/Out	DD1, DD2	<b>DDC Serial Data</b> Serial data for DDC. (0V to 5V)
111	1	In	VREF2	<b>Reference Voltage 2</b> Used to generate the output supply level for the SPD port. This pin should be tied externally to the maximum voltage seen by the ports. (1.5V to 3.3V).
115, 117	2	In/Out	DC1, DC2	<b>DDC Serial Clock</b> Clock for DDC. (0V to 5V)
123-126, 56, 57	6	In/Out	GPIO[5:0]	<b>General Purpose Input / Output [5:0]</b> These pins provide general purpose I/O and are controlled via the serial port. (3.3V). See description of GPIO Controls for I/O configuration.
127	1	Out	ENAVDD	<b>Panel Power Enable</b> Enable panel VDD. (3.3V)
128	1	Out	ENABLK	<b>Back Light Enable</b> Enable Back-Light of LCD Panel. (3.3V)



**Table 1: Pin Description (Continued)**

Pin #	# of Pins	Type	Symbol	Description
121	1	In	HPD	<b>Hot Plug Detect</b> (Internal Pull-down) This input pin determines whether a display device is connected to the VGA connector. When terminated, the display device is required to apply a voltage greater than 2.4 volts. Changes on the status of this pin will be relayed to the graphics controller via the HPINT* pin pulling low.
122	1	Out	HPINT*	<b>Hot Plug Interrupt Output</b> This pin provides an open drain output, which pulls low when a termination change has been detected on the HPD input.
36	1	In	VSWING	<b>LVDS Voltage Swing Control</b> This pin sets the swing level of the LVDS outputs. A 2.4K Ohm resistor should be connected between this pin and LGND (pin 35) using short and wide traces.
58	1	In	RESET*	<b>Reset * Input</b> (Internal Pull-up) When this pin is low, the device is held in the power-on reset condition. When this pin is high, reset is controlled through the serial port.
2	1	Analog	LPLLCAP	<b>LVDS PLL Capacitor</b> This pin allows coupling of any signal to the on-chip loop filter capacitor.
5, 24	2	Out	LL2C, LL1C	<b>Positive LVDS differential Clock2 &amp; Clock1</b>
6, 25	2	Out	LL2C*, LL1C*	<b>Negative LVDS differential Clock2 &amp; Clock1</b>
8, 11, 14, 17	4	Out	LDC[7:4]	<b>Positive LVDS differential data[7:4]</b>
9, 12, 15, 18	4	Out	LDC[7:4]*	<b>Negative LVDS differential data[7:4]</b>
21, 27, 30, 33	4	Out	LDC[3:0]	<b>Positive LVDS differential data[3:0]</b>
22, 28, 31, 34	4	Out	LDC[3:0]*	<b>Negative LVDS differential data [3:0]</b>
38	1	Analog	ISET	<b>Current Set Resistor Input</b> This pin sets the DAC current. A 140-ohm resistor should be connected between this pin and DAC_GND (pin 39) using short and wide traces.
41	1	Out	CVBS (DACA3)	<b>Composite Video</b> This pin outputs a composite video signal capable of driving a 75 ohm doubly terminated load. During bypass modes this output is valid only if the data format is compatible with one of the TV-Out display modes.
42	1	Out	Y/G (DACB1)	<b>Luma / Green Output</b> This pin outputs a selectable video signal. The output is designed to drive a 75 ohm doubly terminated load. The output can be selected to be the luminance component of YPrPb or green (for VGA bypass)
43	1	Out	Y/G (DACA1)	<b>Luma / Green Output</b> This pin outputs a selectable video signal. The output is designed to drive a 75 ohm doubly terminated load. The output can be selected to be s-video luminance or green (for SCART type 1 connections) or the luminance component of YPrPb or green (for VGA bypass)
44	1	Out	Pr/R (DACB2)	<b>Pr / Red Output</b> This pin outputs a selectable video signal. The output is designed to drive a 75 ohm doubly terminated load. The output can be selected to be the Pr component of YPrPb or red (for VGA bypass)
45	1	Out	C/R/Pr (DACA2)	<b>Chroma / Red Output</b> This pin outputs a selectable video signal. The output is designed to drive a 75 ohm doubly terminated load. The output can be selected to be s-video chrominance or red (for SCART type 1 connections) or the Pr component of YPrPb or red (for VGA bypass)
46	1	Out	Pb/B (DACB0)	<b>Pb / Blue Output</b> This pin outputs a selectable video signal. The output is designed to drive a 75 ohm doubly terminated load. The output can be selected to be the Pb component of YPrPb or blue (for VGA bypass).
47	1	Out	CVBS/B/Pb (DACA0)	<b>Composite Video / Blue Output</b> This pin outputs a selectable video signal. The output is designed to drive a 75 ohm doubly terminated load. The output can be selected to be composite video or blue (for SCART type 1 connections) or the Pb component of YPrPb or blue (for VGA bypass).
120	1	Out	VOUT	<b>V-Sync Output</b> This pin is the output of a voltage translating digital buffer and is driven from V5V.



**Table 1: Pin Description (Continued)**

Pin #	# of Pins	Type	Symbol	Description
110	1	In	VIN	<b>V-Sync Input</b> This pin is the input of a voltage translating digital buffer. Input threshold can be programmed by serial port to equal to VREF2/2 or to DVDD/2.
119	1	Out	HOUT	<b>H-Sync Output</b> This pin is the output of a voltage translating digital buffer and is driven from V5V.
109	1	In	HIN	<b>H-Sync Input</b> This pin is the input of a voltage translating digital buffer. Input threshold can be programmed by serial port to equal to VREF2/2 or to DVDD/2.
49	1	Out	C/HSYNC	<b>Composite / Horizontal Sync</b> This pin provides composite sync in TV modes and horizontal sync in bypass RGB mode. This pin is driven by the DVDD supply.
50	1	Out	BCO/VSYNC	<b>Buffered Clock Outputs / Vertical Sync</b> This output pin provides buffered crystal oscillator clock output or VSYNC output in bypass RGB mode. This pin is driven by the DVDD supply.
52	1	In	XI / FIN	<b>Crystal Input / External Reference Input</b> A parallel resonant 14.31818MHz crystal ( $\pm 20$ ppm) should be attached between this pin and XO. However, an external CMOS compatible clock can drive the XI/FIN input.
53	1	Out	XO	<b>Crystal Output</b> A parallel resonance 14.31818MHz crystal ( $\pm 20$ ppm) should be attached between this pin and XI / FIN. However, if an external CMOS clock is attached to XI/FIN, XO should be left open.
59	1	Out	P-Out	<b>Pixel Clock Output</b> This pin provides a pixel clock signal to the VGA controller, which can be used as a reference frequency. The output is selectable between 1X and 2X of the pixel clock frequency. The output driver is driven from the VDDV supply (pin 60). This output has a programmable tri-state. The capacitive loading on this pin should be kept to a minimum.
61	1	In	VREF1	<b>Reference Voltage Input 1</b> The VREF1 pin inputs a reference voltage of VDDV / 2. The signal is derived externally through a resistor divider and decoupling capacitor, and will be used as a reference level for data, sync and clock inputs.
68-73, 77-82	12	In	D1[11:0]	<b>Data1[11] through Data1[0] Inputs</b> These pins accept the 12 data inputs from a digital video port of a graphics controller. The levels are 0 to VDDV. VREF1 is the threshold level.
76, 74	2	In	XCLK1, XCLK1*	<b>External Clock Inputs</b> These inputs form a differential clock signal input to the device for use with the H1, V1 and D1[11:0] data. If differential clocks are not available, the XCLK1* input should be connected to VREF1. The clock polarity can be selected by the MCP1 control bit.
85-90, 94-99	12	In	D2[11:0]	<b>Data2[11] through Data2[0] Inputs</b> These pins accept the 12 data inputs from a digital video port of a graphics controller. The levels are 0 to VDDV. VREF1 is the threshold level.
93, 91	2	In	XCLK2, XCLK2*	<b>External Clock Inputs</b> These inputs form a differential clock signal input to the device for use with the H2, V2 and D2[11:0] data. If differential clocks are not available, the XCLK2* input should be connected to VREF1. The clock polarity can be selected by the MCP2 control bit.
118	1	Power	V5V	<b>5V supply for H/VOUT (5V)</b>
64, 83, 84, 103	4	Power	DVDD	<b>Digital Supply Voltage (3.3V)</b>
67, 75, 92, 100	4	Power	DGND	<b>Digital Ground</b>
60	1	Power	VDDV	<b>I/O Supply Voltage (1.1V to 3.3V)</b>
55	2	Power	TVPLL_VDD	<b>TV PLL Supply Voltage (3.3V)</b>
54	1	Power	TVPLL_VCC	<b>TV PLL Supply Voltage (3.3V)</b>
51	1	Power	TVPLL_GND	<b>TV PLL Ground</b>
37	1	Power	DAC_VDD	<b>DAC Supply Voltage (3.3V)</b>



**Table 1: Pin Description (Continued)**

<b>Pin #</b>	<b># of Pins</b>	<b>Type</b>	<b>Symbol</b>	<b>Description</b>
39, 48	1	Power	DAC_GND	<b>DAC Ground</b>
7, 13, 19, 20, 26, 32	6	Power	LVDD	<b>LVDS Supply Voltage (3.3V)</b>
4, 10, 16, 23, 29, 35	6	Power	LGND	<b>LVDS Ground</b>
1	1	Power	LPLL_VDD	<b>LVDS PLL Supply Voltage (3.3V)</b>
3	1	Power	LPLL_GND	<b>LVDS PLL Ground</b>



**3.0 Overview**

The CH7017/CH7018 is a VGA to TV encoder with dual LVDS output for the graphics subsystem. Both TV-Out and LVDS-Out can operate simultaneously if the two 12-bit input ports are driven from different timing generators. TV timing requirements are usually different from that of the TFT-LCD panels. If the graphics controller can generate only one set of timing, simultaneous display on both the TV and the flat panel may not be available for all graphics modes. The blockdiagram of the device and the data flow within it is shown on **Figure 1**.

The CH7017/CH7018 also supports 24-bit input mode by ganging D1 and D2 together as a single 24-bit data port. In this case the timing signals H1, V1, DE1, XCLK1 and XCLK1\* are equal to H2, V2, DE2, XCLK2 and XCLK2\*, respectively. Video data are sent to either the TV encoder (including RGB bypass) or to the LVDS data path, but not both. Maximum data rate supported through the dual LVDS links is 330M Pixels /sec. The maximum pixel rate supported by the RGB bypass mode is 165 Mpixels/sec.

**3.1 Input Interface Timing**

Four distinct methods of transferring data to the CH7017/CH7018 are described below. In each of the four modes, DE<sub>x</sub> is used to signal active LVDS data for the panel and register SAV value denotes the start of active TV video.

**A. 12-bit Multiplexed Data – Dual-edge Transfer**

- Multiplexed data - two 12-bit words per pixel from either D1[11:0] or D2[11:0]
- Clock frequency equals 1X pixel rate with 12-bit data transfer at both rising and falling clock edges.
- Maximum pixel rate is 165M pixels per second with a 165 MHz pixel clock.

Simultaneous TV and panel display.

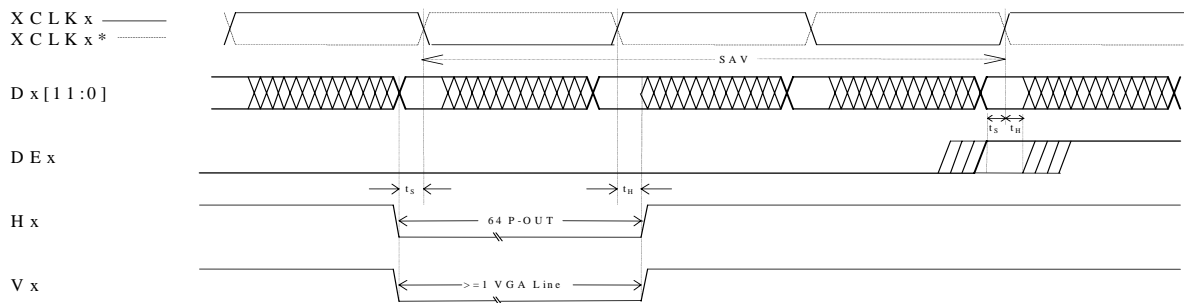

**Figure 3: Interface Timing for Multiplexed Data – Dual-edge Transfer**

**B. 12-bit Multiplexed Data – Single-edge Transfer**

- Multiplexed data - two 12-bit words per pixel from either D1[11:0] or D2[11:0]
- Clock frequency equals 2X pixel rate with 12-bit data transfer at either rising or falling edge of clock (programmable via serial port).
- Maximum pixel rate is 165M pixels per second with a 330 MHz pixel clock.
- Simultaneous TV and panel display.





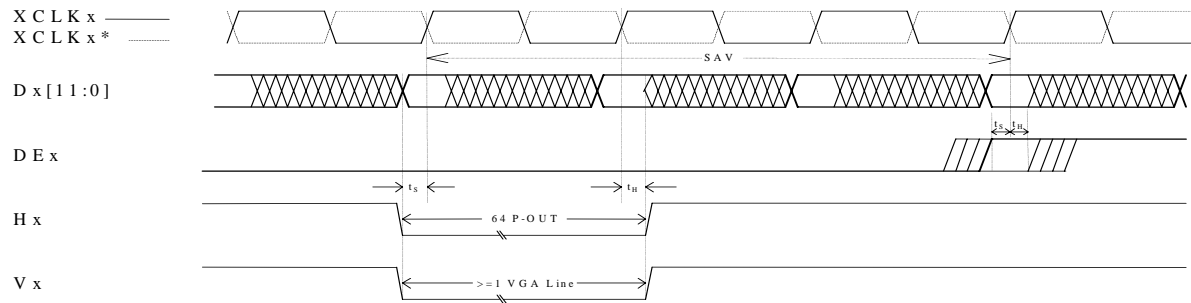

Figure 4: Interface Timing for Multiplexed Data – Single-edge Transfer

**C. 24-bit Ganged Data – Dual-edge Transfer**

- Multiplexed data - two 24-bit words per pixel from both D1[11:0] and D2[11:0]
- Clock frequency equals 1/2X pixel rate with 24-bit data transfer at both rising and falling clock edges.
- Maximum pixel rate is 330M pixels per second with a 165 MHz pixel clock.
- No Simultaneous TV and LVDS panel display.

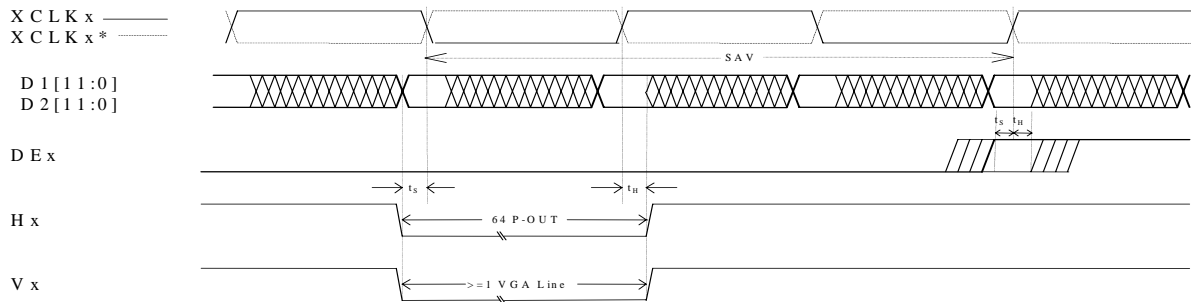

Figure 5: Interface Timing for 24-bit Multiplexed Data – Dual-edge Transfer

**D. 24-bit Ganged Data – Single-edge Transfer**

- Non-multiplexed data - one 24-bit word per pixel from both D1[11:0] and D2[11:0].
- Clock frequency equals 1X pixel rate with 24-bit data transfer at either rising or falling edge of clock (programmable via serial port).
- Maximum pixel rate is 330M pixels per second with a 330 MHz pixel clock.
- No simultaneous TV and LVDS panel display.





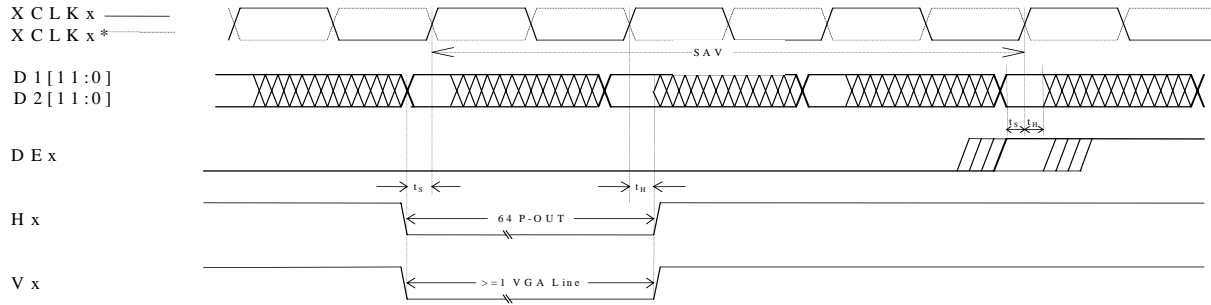

**Figure 6: Interface Timing for Non-multiplexed Data – Single-edge Transfer**

**Table 2: Interface Timing Specifications**

Symbol	Parameter	Min	Typ	Max	Unit
$t_s$	Setup time	See section 5.5			ns
$t_H$	Hold time	See section 5.5			ns

Note:  $t_s$ ,  $t_H$ , setup time and hold time are programmable through serial port – X1CMD [3:0] and X2CMD[3:0] by delay or advance of clock relative to data.



### 3.2 Input Data Formats

#### 3.2.1 12-Bit Multiplexed Data Formats

Multiplexed pixel data inputs to the CH7017/CH7018 through D1[11:0] or D2[11:0] using data transfer method A or B is described in 3.1. Received data is formatted and sent through an internal data bus P1[23:0] to TV encoder or directly to the TV DACs, or through bus P2[23:0] to the LVDS data path. The multiplexed input data formats are (IDF1[3:0]=0,1,2,3 and 4 for D1 and IDF2[3:0]=0,1,2,3 and 4 for D2):

IDFx	Description
0	RGB 8-8-8 (2x12-bit)
1	RGB 8-8-8 (2x12-bit) or RGB 5-6-5 (2x8-bit)
2	RGB 5-6-5 (2x8bit)
3	RGB 5-5-5 (2x8-bit)
4	YCrCb 8-8 (2x8-bit)

For multiplexed input data formats, data can be latched from the graphics controller by either rising only or falling only clock edges, or by both rising and falling clock edges. The MCPx bits select the rising or the falling clock edge, where rising refers to rising edge on the XCLKx signals and falling edge on the XCLKx\* signals. The multiplexed input data formats are shown in **Figure 7**. The input data bus Dx[11:0], where x can be either 1 or 2, transports a 12-bit or 8-bit multiplexed data stream containing either RGB or YCrCb formatted data. The input data rate is 2X the pixel rate and each pair of Pn values (e.g.; P0a and P0b) contains a complete pixel encoded as shown in the Tables 3 to 6 below and can be placed onto one or both of the internal pixel buses Py[23:0], where y equals 1 or 2. It is assumed that the first clock cycle following the leading edge of the incoming horizontal sync signal contains the first word (Pxa) of a pixel, if an active pixel was present immediately following the horizontal sync. When the input is a YCrCb data stream the color-difference data will be transmitted at half the data rate of the luminance data with the sequence being set as Cb0, Y0, Cr0, Y1, where Cb0,Y0,Cr0 refers to co-sited luminance and color-difference samples and the following Y1 byte refers to the next luminance sample, per CCIR-656 standards (the clock frequency is dependent upon the current mode, and is not 27MHz as specified in CCIR-656). All non-active pixels should be 0 in RGB formats, and 16 for Y and 128 for CrCb in YCrCb formats.

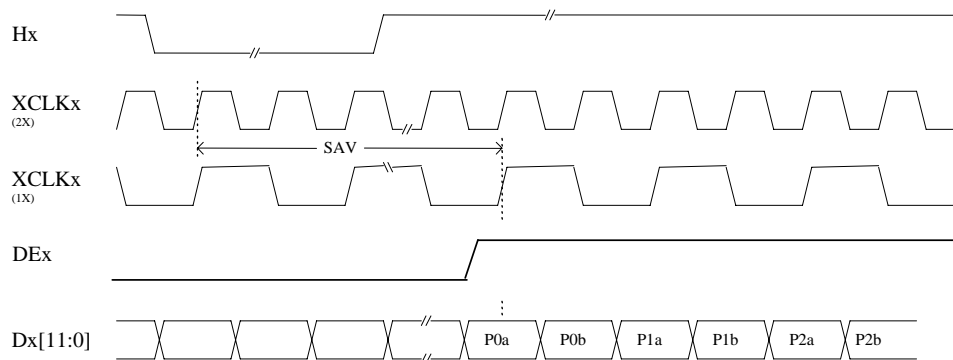

**Figure 7: 12-bit Multiplexed Input Data Formats (IDFx = 0,1,2,3,4)**



**Table 3: Multiplexed Input Data Formats (IDF<sub>x</sub> = 0, 1)**

IDF <sub>x</sub> = Format =		0 RGB 8-8-8 (2x12-bit) For TV/Bypass RGB or/and LVDS				1 RGB 8-8-8 (2x12-bit) or RGB 5-6-5 (2x8-bit) For TV/Bypass RGB or/and LVDS			
		P0a	P0b	P1a	P1b	P0a	P0b	P1a	P1b
Pixel #									
Bus Data	Dx[11]	G0[3]	R0[7]	G1[3]	R1[7]	G0[4]	R0[7]	G1[4]	R1[7]
	Dx[10]	G0[2]	R0[6]	G1[2]	R1[6]	G0[3]	R0[6]	G1[3]	R1[6]
	Dx[9]	G0[1]	R0[5]	G1[1]	R1[5]	G0[2]	R0[5]	G1[2]	R1[5]
	Dx[8]	G0[0]	R0[4]	G1[0]	R1[4]	B0[7]	R0[4]	B1[7]	R1[4]
	Dx[7]	B0[7]	R0[3]	B1[7]	R1[3]	B0[6]	R0[3]	B1[6]	R1[3]
	Dx[6]	B0[6]	R0[2]	B1[6]	R1[2]	B0[5]	G0[7]	B1[5]	G1[7]
	Dx[5]	B0[5]	R0[1]	B1[5]	R1[1]	B0[4]	G0[6]	B1[4]	G1[6]
	Dx[4]	B0[4]	R0[0]	B1[4]	R1[0]	B0[3]	G0[5]	B1[3]	G1[5]
	Dx[3]	B0[3]	G0[7]	B1[3]	G1[7]	G0[0]	R0[2]	G1[0]	R1[2]
	Dx[2]	B0[2]	G0[6]	B1[2]	G1[6]	B0[2]	R0[1]	B1[2]	R1[1]
	Dx[1]	B0[1]	G0[5]	B1[1]	G1[5]	B0[1]	R0[0]	B1[1]	R1[0]
	Dx[0]	B0[0]	G0[4]	B1[0]	G1[4]	B0[0]	G0[1]	B1[0]	G1[1]

**Table 4: Multiplexed Input Data Formats (IDF<sub>x</sub> = 2, 3)**

IDF <sub>x</sub> = Format =		2 RGB 5-6-5 (2x8bit) For TV/Bypass RGB or/and LVDS				3 RGB 5-5-5 (2x8-bit) for TV/Bypass RGB or/and LVDS			
		P0a	P0b	P1a	P1b	P0a	P0b	P1a	P1b
Pixel #									
Bus Data	Dx[11]	G0[4]	R0[7]	G1[4]	R1[7]	G0[5]	X	G1[5]	X
	Dx[10]	G0[3]	R0[6]	G1[3]	R1[6]	G0[4]	R0[7]	G1[4]	R1[7]
	Dx[9]	G0[2]	R0[5]	G1[2]	R1[5]	G0[3]	R0[6]	G1[3]	R1[6]
	Dx[8]	B0[7]	R0[4]	B1[7]	R1[4]	B0[7]	R0[5]	B1[7]	R1[5]
	Dx[7]	B0[6]	R0[3]	B1[6]	R1[3]	B0[6]	R0[4]	B1[6]	R1[4]
	Dx[6]	B0[5]	G0[7]	B1[5]	G1[7]	B0[5]	R0[3]	B1[5]	R1[3]
	Dx[5]	B0[4]	G0[6]	B1[4]	G1[6]	B0[4]	G0[7]	B1[4]	G1[7]
	Dx[4]	B0[3]	G0[5]	B1[3]	G1[5]	B0[3]	G0[6]	B1[3]	G1[6]

**Table 5: Multiplexed Input Data Formats (IDF<sub>x</sub> = 4)**

IDF <sub>x</sub> = Format =		4 YCrCb 4:2:2 (2x8-bit) for TV							
		P0a	P0b	P1a	P1b	P2a	P2b	P3a	P3b
Pixel #									
Bus Data	Dx[7]	Cb0[7]	Y0[7]	Cr0[7]	Y1[7]	Cb2[7]	Y2[7]	Cr2[7]	Y3[7]
	Dx[6]	Cb0[6]	Y0[6]	Cr0[6]	Y1[6]	Cb2[6]	Y2[6]	Cr2[6]	Y3[6]
	Dx[5]	Cb0[5]	Y0[5]	Cr0[5]	Y1[5]	Cb2[5]	Y2[5]	Cr2[5]	Y3[5]
	Dx[4]	Cb0[4]	Y0[4]	Cr0[4]	Y1[4]	Cb2[4]	Y2[4]	Cr2[4]	Y3[4]
	Dx[3]	Cb0[3]	Y0[3]	Cr0[3]	Y1[3]	Cb2[3]	Y2[3]	Cr2[3]	Y3[3]
	Dx[2]	Cb0[2]	Y0[2]	Cr0[2]	Y1[2]	Cb2[2]	Y2[2]	Cr2[2]	Y3[2]
	Dx[1]	Cb0[1]	Y0[1]	Cr0[1]	Y1[1]	Cb2[1]	Y2[1]	Cr2[1]	Y3[1]
	Dx[0]	Cb0[0]	Y0[0]	Cr0[0]	Y1[0]	Cb2[0]	Y2[0]	Cr2[0]	Y3[0]

When IDF<sub>x</sub> = 4 (YCrCb mode), the data inputs can also be used to transmit sync information to the device. In this mode, the embedded sync will follow the VIP2 convention, and the first byte of the ‘video timing reference code’ will be assumed to occur when a Cb sample would occur, if the video stream is continuous.



**Table 6: Multiplexed Input Data Formats (IDFx = 4) with Embedded Sync**

IDFx = Format =	4 YCrCb 4:2:2 (2x8-bit) for TV								
Pixel #		P0a	P0b	P1a	P1b	P2a	P2b	P3a	P3b
Bus Data	Dx[7]	1	0	0	S[7]	Cb2[7]	Y2[7]	Cr2[7]	Y3[7]
	Dx[6]	1	0	0	S[6]	Cb2[6]	Y2[6]	Cr2[6]	Y3[6]
	Dx[5]	1	0	0	S[5]	Cb2[5]	Y2[5]	Cr2[5]	Y3[5]
	Dx[4]	1	0	0	S[4]	Cb2[4]	Y2[4]	Cr2[4]	Y3[4]
	Dx[3]	1	0	0	S[3]	Cb2[3]	Y2[3]	Cr2[3]	Y3[3]
	Dx[2]	1	0	0	S[2]	Cb2[2]	Y2[2]	Cr2[2]	Y3[2]
	Dx[1]	1	0	0	S[1]	Cb2[1]	Y2[1]	Cr2[1]	Y3[1]
	Dx[0]	1	0	0	S[0]	Cb2[0]	Y2[0]	Cr2[0]	Y3[0]

In this mode, the S[7..0] byte contains the following data:

S[6] = F = 1 during field 2, 0 during field 1

S[5] = V = 1 during field blanking, 0 elsewhere

S[4] = H = 1 during EAV (synchronization reference at the end of active video)  
0 during SAV (synchronization reference at the start of active video)

S[7] and S[3:0] are ignored.

**3.2.2 24-Bit Data Formats**

The two 12-bit input data ports, D1[11:0] and D2[11:0], can be grouped together to form a single 24-bit interface to the graphic controller. In this case the timing signals H1, V1, DE1, XCLK1 and XCLK1\* are equal to H2, V2, DE2, XCLK2 and XCLK2\*, respectively. The CH7017/CH7018 supports 5 different 24-bit data formats. Each of which is used with a 1X pixel rate clock latching data with one of the clock edges (default is falling edge). The 24-bit input data formats are IDFx[3:0]=5,6,7,8 and 9 (note that IDF1 must be set equal to IDF2) and are illustrated in **Figure 8** below.

IDFx	Description
5	RGB 8-8-8 (1x24-bit) for TV/Bypass RGB
6	YCrCb 8-8 (1x16-bit with CrCb multiplexed and decimated by 2) for TV
7	YCrCb 8-8-8 (1x24-bit) for TV
8	RGB 8-8-8 (2x24-bit) Odd / Even Ganged for LVDS
9	RGB 8-8-8 (1x24-bit) Normal Ganged for LVDS

The pixel data bus represents a 24-bit or 16-bit data stream containing either RGB or YCrCb formatted data. When the input is a 16-bit YCrCb data stream the color-difference data will be transmitted at half the data rate of the luminance data, with the sequence being set as Cb0, Y0 transmitted during one clock cycle, followed by Cr0, Y1 the following clock cycle, where Cb0,Y0,Cr0 refers to co-sited luminance and color-difference samples and the Y1 data refers to the next luminance sample, per CCIR-601 sampling. Non-active data must be 0 in RGB format, and 16 for Y, 128 for Cr and Cb in YCrCb formats.

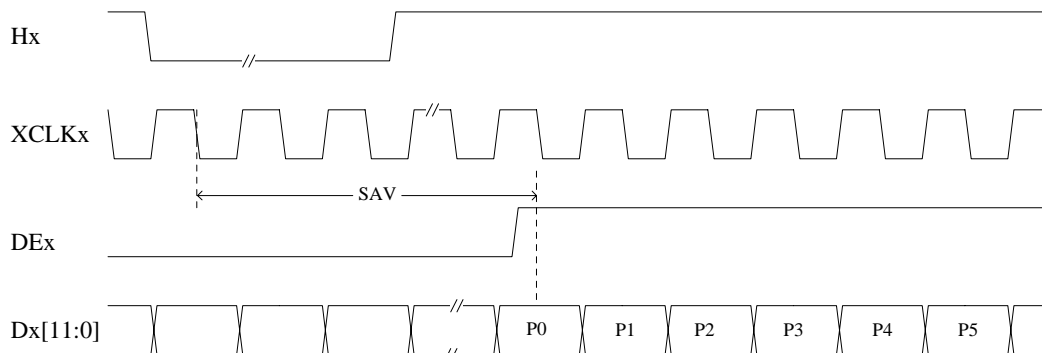

**Figure 8: Non-Multiplexed Input Data Formats (IDFx = 5,6,7,8 and 9)**



**Table 7: Non-Multiplexed Data Formats**

IDF <sub>x</sub> = Format =	Pixel #	5 24-bit RGB for TV/Bypass RGB		6 16-bit YCrCb FOR TV				7 24-bit YCrCb FOR TV		
		P0	P1	P0	P1	P2	P3	P0	P1	
Bus Data	D1[11]	R0[7]	R1[7]	Y0[7]	Y1[7]	Y2[7]	Y3[7]	Y0[7]	Y1[7]	
	D1[10]	R0[6]	R1[6]	Y0[6]	Y1[6]	Y2[6]	Y3[6]	Y0[6]	Y1[6]	
	D1[9]	R0[5]	R1[5]	Y0[5]	Y1[5]	Y2[5]	Y3[5]	Y0[5]	Y1[5]	
	D1[8]	R0[4]	R1[4]	Y0[4]	Y1[4]	Y2[4]	Y3[4]	Y0[4]	Y1[4]	
	D1[7]	R0[3]	R1[3]	Y0[3]	Y1[3]	Y2[3]	Y3[3]	Y0[3]	Y1[3]	
	DVOB	D1[6]	R0[2]	R1[2]	Y0[2]	Y1[2]	Y2[2]	Y3[2]	Y0[2]	Y1[2]
		D1[5]	R0[1]	R1[1]	Y0[1]	Y1[1]	Y2[1]	Y3[1]	Y0[1]	Y1[1]
		D1[4]	R0[0]	R1[0]	Y0[0]	Y1[0]	Y2[0]	Y3[0]	Y0[0]	Y1[0]
		D1[3]	G0[7]	G1[7]	Cr0[7]	Cb0[7]	Cr2[7]	Cb2[7]	Cr0[7]	Cr1[7]
		D1[2]	G0[6]	G1[6]	Cr0[6]	Cb0[6]	Cr2[6]	Cb2[6]	Cr0[6]	Cr1[6]
	DVOC	D1[1]	G0[5]	G1[5]	Cr0 [5]	Cb0 [5]	Cr2 [5]	Cb2 [5]	Cr0 [5]	Cr1 [5]
D1[0]		G0[4]	G1[4]	Cr0 [4]	Cb0 [4]	Cr2 [4]	Cb2 [4]	Cr0 [4]	Cr1 [4]	
D2[11]		G0[3]	G1[3]	Cr0 [3]	Cb0 [3]	Cr2 [3]	Cb2 [3]	Cr0 [3]	Cr1 [3]	
D2[10]		G0[2]	G1[2]	Cr0 [2]	Cb0 [2]	Cr2 [2]	Cb2 [2]	Cr0 [2]	Cr1 [2]	
D2[9]		G0[1]	G1[1]	Cr0 [1]	Cb0 [1]	Cr2 [1]	Cb2 [1]	Cr0 [1]	Cr1 [1]	
D2[8]		G0[0]	G1[0]	Cr0 [0]	Cb0 [0]	Cr2 [0]	Cb2 [0]	Cr0 [0]	Cr1 [0]	
D2[7]		B0[7]	B1[7]					Cb0[7]	Cb1[7]	
D2[6]		B0[6]	B1[6]					Cb0[6]	Cb1[6]	
D2[5]		B0[5]	B1[5]					Cb0 [5]	Cb1[5]	
D2[4]		B0[4]	B1[4]					Cb0 [4]	Cb1[4]	
D2[3]	B0[3]	B1[3]					Cb0 [3]	Cb1[3]		
D2[2]	B0[2]	B1[2]					Cb0 [2]	Cb1[2]		
D2[1]	B0[1]	B1[1]					Cb0 [1]	Cb1[1]		
D2[0]	B0[0]	B1[0]					Cb0 [0]	Cb1[0]		



When IDFx = 6 or 7 (YCrCb modes), the data inputs can be used to transmit sync information to the device. In these modes the embedded sync follows a subset of the VIP2 convention, and the first byte of the video timing reference code is assumed to occur when a Cb sample occurs, if the video stream is continuous. This is shown in **Table 8** below.

**Table 8: Non-Multiplexed YCrCb modes with Embedded Sync**

IDFx = Format =		6 16-bit YCrCb for TV				7 24-bit YCrCb for TV			
Pixel #		P0	P1	P2	P3	P0	P1	P2	P3
Bus Data	D1[11]	0	S[7]	Y0[7]	Y1[7]	0	S[7]	Y0[7]	Y1[7]
	D1[10]	0	S[6]	Y0[6]	Y1[6]	0	S[6]	Y0[6]	Y1[6]
	D1[9]	0	S[5]	Y0[5]	Y1[5]	0	S[5]	Y0[5]	Y1[5]
	D1[8]	0	S[4]	Y0[4]	Y1[4]	0	S[4]	Y0[4]	Y1[4]
	D1[7]	0	S[3]	Y0[3]	Y1[3]	0	S[3]	Y0[3]	Y1[3]
	D1[6]	0	S[2]	Y0[2]	Y1[2]	0	S[2]	Y0[2]	Y1[2]
	D1[5]	0	S[1]	Y0[1]	Y1[1]	0	S[1]	Y0[1]	Y1[1]
	D1[4]	0	S[0]	Y0[0]	Y1[0]	0	S[0]	Y0[0]	Y1[0]
	D1[3]	1	0	Cr0[7]	Cb0[7]	1	X	Cr0[7]	Cr1[7]
	D1[2]	1	0	Cr0[6]	Cb0[6]	1	X	Cr0[6]	Cr1[6]
	D1[1]	1	0	Cr0 [5]	Cb0 [5]	1	X	Cr0 [5]	Cr1[5]
	D1[0]	1	0	Cr0 [4]	Cb0 [4]	1	X	Cr0 [4]	Cr1[4]
	D2[11]	1	0	Cr0 [3]	Cb0 [3]	1	X	Cr0 [3]	Cr1[3]
	D2[10]	1	0	Cr0 [2]	Cb0 [2]	1	X	Cr0 [2]	Cr1[2]
	D2[9]	1	0	Cr0 [1]	Cb0 [1]	1	X	Cr0 [1]	Cr1[1]
	D2[8]	1	0	Cr0 [0]	Cb0 [0]	1	X	Cr0 [0]	Cr1[0]
	D2[7]					0	X	Cb0[7]	Cb1[7]
	D2[6]					0	X	Cb0[6]	Cb1[6]
	D2[5]					0	X	Cb0 [5]	Cb1 [5]
	D2[4]					0	X	Cb0 [4]	Cb1 [4]
	D2[3]					0	X	Cb0 [3]	Cb1 [3]
	D2[2]					0	X	Cb0 [2]	Cb1 [2]
	D2[1]					0	X	Cb0 [1]	Cb1 [1]
	D2[0]					0	X	Cb0 [0]	Cb1 [0]

In this mode, the S[7:0] byte contains the following data:

S[6] = F = 1 during field 2, 0 during field 1

S[5] = V = 1 during field blanking, 0 elsewhere

S[4] = H = 1 during EAV (synchronization reference at the end of active video)  
0 during SAV (synchronization reference at the start of active video)

S[7] and S[3:0] are ignored

Under modes 8 and 9, the CH7017/CH7018 takes 24-bit data from both D1 and D2 and outputs to the dual LVDS links. A maximum throughput of 330M pixels per second can be achieved. The timing signals of both input ports shall be identical. H1, V1 and XCLK1 equal H2, V2 and XCLK2, respectively. Up-scaling and dithering functions are not available in these modes.



**Table 9: Ganged Data Formats**

IDF <sub>x</sub> = Format =	Pixel #	8 24-bit RGB Odd/Even Ganged for LVDS		9 24-bit RGB Normal Ganged for LVDS		
		P0	P1	P0	P1	
Bus Data	D1[11]	G0[3]	R0[7]	R0[7]	R1[7]	
	D1[10]	G0[2]	R0[6]	R0[6]	R1[6]	
	D1[9]	G0[1]	R0[5]	R0[5]	R1[5]	
	D1[8]	G0[0]	R0[4]	R0[4]	R1[4]	
	D1[7]	B0[7]	R0[3]	R0[3]	R1[3]	
	DVOB	D1[6]	B0[6]	R0[2]	R0[2]	R1[2]
		D1[5]	B0[5]	R0[1]	R0[1]	R1[1]
		D1[4]	B0[4]	R0[0]	R0[0]	R1[0]
D1[3]		B0[3]	G0[7]	G0[7]	G1[7]	
D1[2]		B0[2]	G0[6]	G0[6]	G1[6]	
D1[1]		B0[1]	G0[5]	G0[5]	G1[5]	
D1[0]		B0[0]	G0[4]	G0[4]	G1[4]	
DVOC		D2[11]	G1[3]	R1[7]	G0[3]	G1[3]
	D2[10]	G1[2]	R1[6]	G0[2]	G1[2]	
	D2[9]	G1[1]	R1[5]	G0[1]	G1[1]	
	D2[8]	G1[0]	R1[4]	G0[0]	G1[0]	
	D2[7]	B1[7]	R1[3]	B0[7]	B1[7]	
	D2[6]	B1[6]	R1[2]	B0[6]	B1[6]	
	D2[5]	B1[5]	R1[1]	B0[5]	B1[5]	
	D2[4]	B1[4]	R1[0]	B0[4]	B1[4]	
	D2[3]	B1[3]	G1[7]	B0[3]	B1[3]	
	D2[2]	B1[2]	G1[6]	B0[2]	B1[2]	
	D2[1]	B1[1]	G1[5]	B0[1]	B1[1]	
	D2[0]	B1[0]	G1[4]	B0[0]	B1[0]	





**3.3 TV-Out**

Multiplexed input data, sync and clock signals from the graphics controller inputs to the CH7017/CH7018 through one of the two 12-bit variable voltage input ports, D1[11:0] or D2[11:0], and is directed to the TV data path. Non-multiplexed 24-bit input data also inputs through both of the two input ports. Detailed descriptions of the eight input data formats are given in **Section 3.2**. Clock signal (P-Out) outputs as a frequency reference to the graphics controller to ensure accurate frequency generation. Horizontal and vertical sync signals are normally sent to the CH7017/CH7018 from the graphics controller, but can be optionally generated by the CH7017/CH7018 and output to the graphics controller. Using the serial port, the CH7017/CH7018 can be programmed as the clock master, clock slave, sync master or sync slave. Data will be 2X multiplexed (2x12 bits) or non-multiplexed (1x24 bits), and the XCLK clock signal can be 1X or 2X times the pixel rate. The input data will be encoded into the selected video standard, and output from the video DACs.

**In order to minimize the hazard of ESD, a set of protection diodes MUST BE used for each DAC connecting to TV (Refer to AN-38 for details).**

**3.3.1 Display Modes**

The CH7017/CH7018 display mode is controlled by three independent factors: Input resolution, TV format, and scale factor, which are programmed via the display mode Register. It is designed to accept input resolutions of 512x384, 640x480, 640x400, 720x400, 720x480, 720x576, 800x600, and 1024x768.

It is designed to support output to either NTSC or PAL television formats. The CH7017/CH7018 provides interpolated scaling with selectable factors of 5:4, 1:1, 7:8, 5:6, 3:4, 7:10 and 25:21 in order to support adjustable overscan or underscan operation when displayed on a TV. The modes supported for TV-Out are shown in **Table 10** below.

**Table 10: TV Output Modes**

Graphics Resolution	Active Aspect Ratio	Pixel Aspect Ratio	TV Output Standard	Scaling Ratios
512x384	4:3	1:1	PAL	5/4, 1/1
512x384	4:3	1:1	NTSC	5/4, 1/1
720x400	4:3	1.35:1.00	PAL	5/4, 1/1
720x400	4:3	1.35:1.00	NTSC	5/4, 1/1, 25/21
640x400	8:5	1:1	PAL	5/4, 1/1
640x400	8:5	1:1	NTSC	5/4, 1/1, 7/8, 25/21
640x480	4:3	1:1	PAL	5/4, 1/1, 5/6, 25/21
640x480	4:3	1:1	NTSC	1/1, 7/8, 5/6
720x480 <sup>1</sup>	4:3	9:8	NTSC	1/1
720x480 <sup>2</sup>	4:3	9:8	NTSC	1/1, 7/8, 5/6
720x576 <sup>1</sup>	4:3	15:12	PAL	1/1
720x576 <sup>2</sup>	4:3	15:12	PAL	1/1, 5/6, 5/7
800x600	4:3	1:1	PAL	1/1, 5/6, 5/7
800x600	4:3	1:1	NTSC	3/4, 7/10, 5/8
1024x768	4:3	1:1	PAL	5/7, 5/8, 5/9
1024x768	4:3	1:1	NTSC	5/8, 5/9, 1/2

<sup>1</sup> These DVD modes operate with interlaced input. Scan conversion and flicker filter are bypassed.

<sup>2</sup> These DVD modes operate with non-interlaced input. Scan conversion and flicker filter are not bypassed.

**3.3.2 Adaptive Flicker Filter**

The CH7017/CH7018 integrates an advanced 2-line to 7-line (depending on mode) vertical deflickering filter circuit to help eliminate the flicker associated with interlaced displays. This flicker circuit provides an adaptive filter algorithm for implementing flicker reduction with selections of high, medium or low flicker content for both luma and chroma channels (see Register descriptions). In addition, a special text enhancement circuit incorporates additional filtering for enhancing the readability of text. These modes are fully programmable via serial port interface using the flicker filter Register (Reg. 01h).



### 3.3.3 Color Burst Generation\*

The CH7017/CH7018 allows the subcarrier frequency to be accurately generated from a 14.31818 MHz crystal oscillator, leaving the subcarrier frequency independent of the graphics pixel clock frequency. As a result, the CH7017/CH7018 may be used with most VGA chips (with an appropriate digital interface) since the CH7017/CH7018 subcarrier frequency can be generated without being dependent on the precise pixel rates of VGA controllers. This feature is important since even a  $\pm 0.01\%$  subcarrier frequency variation is enough to cause some televisions to lose color lock.

In addition, the CH7017/CH7018 has the capability to genlock the color burst signal to the VGA horizontal sync frequency, which enables a fully synchronous system between the graphics controller and the television. When genlocked, the CH7017/CH7018 can stop “dot crawl” motion (for composite NTSC modes), thus eliminating the annoyance of moving borders. Both of these features are under programmable control through a set of registers.

### 3.3.4 NTSC and PAL Operation

Composite and S-Video outputs are supported in either NTSC or PAL format. The general parameters used to characterize these outputs are listed in **Table 11** and shown in **Figure 9**. (See **Figure 10** through **Figure 17** for illustrations of composite and S-Video output waveforms).

#### ITU-R BT.470 Compliance

The CH7017/CH7018 is predominantly compliant with the recommendations called out in ITU-R BT.470. The following are the only exceptions to this compliance:

- The frequencies of  $F_{sc}$ ,  $F_h$ , and  $F_v$  can only be guaranteed in clock/sync master mode, not in clock/sync slave mode when the graphics device generates these frequencies.
- It is assumed that gamma correction, if required, is performed in the graphics device which establishes the color reference signals.
- All modes provide the exact number of lines called out for NTSC and PAL modes respectively, except mode 21, which outputs 800x600 resolution, scaled by 3:4, to PAL format with a total of 627 lines (vs. 625).
- Chroma signal frequency response will fall within 10% of the exact recommended value.
- Pulse widths and rise/fall times for sync pulses, front/back porches, and equalizing pulses are designed to approximate ITU-R BT.470 requirements, but will fall into a range of values due to the variety of clock frequencies used to support multiple operating modes.

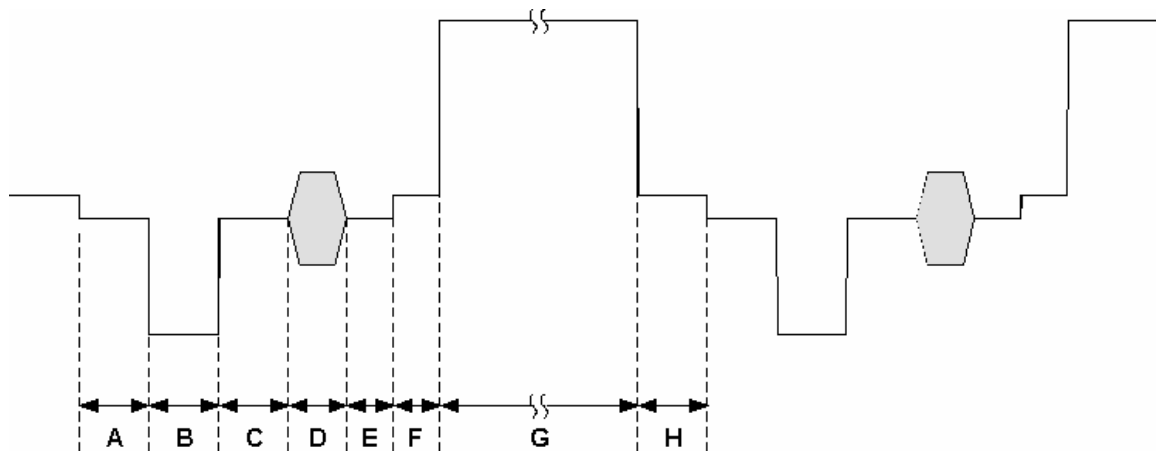

**Table 11: NTSC/PAL Composite Output Timing Parameters (in ms)**

Symbol	Description	Level (mV)		Duration ( $\mu$ s)	
		NTSC	PAL	NTSC	PAL
A	Front Porch	287	300	1.49 - 1.51	1.48 - 1.51
B	Horizontal Sync	0	0	4.69 - 4.72	4.69 - 4.71
C	Breezeway	287	300	0.59 - 0.61	0.88 - 0.92
D	Color Burst	287	300	2.50 - 2.53	2.24 - 2.26
E	Back Porch	287	300	1.55 - 1.61	2.62 - 2.71
F	Black	340	300	0.00 - 7.50	0.00 - 8.67
G	Active Video	340	300	37.66 - 52.67	34.68 - 52.01
H	Black	340	300	0.00 - 7.50	0.00 - 8.67

Note:

1.  $R(ISET) = 140$  ohms (external resistor connected to ISET);  $V(ISET) = 1.235V$ ; 75 ohms doubly terminated load.
2. Durations vary slightly in different modes due to the different clock frequencies used.
3. Active video and black (F, G, H) times vary greatly due to different scaling ratios used in different modes.
4. Black times (F and H) vary with position controls.



**Figure 9: NTSC / PAL Composite Output**



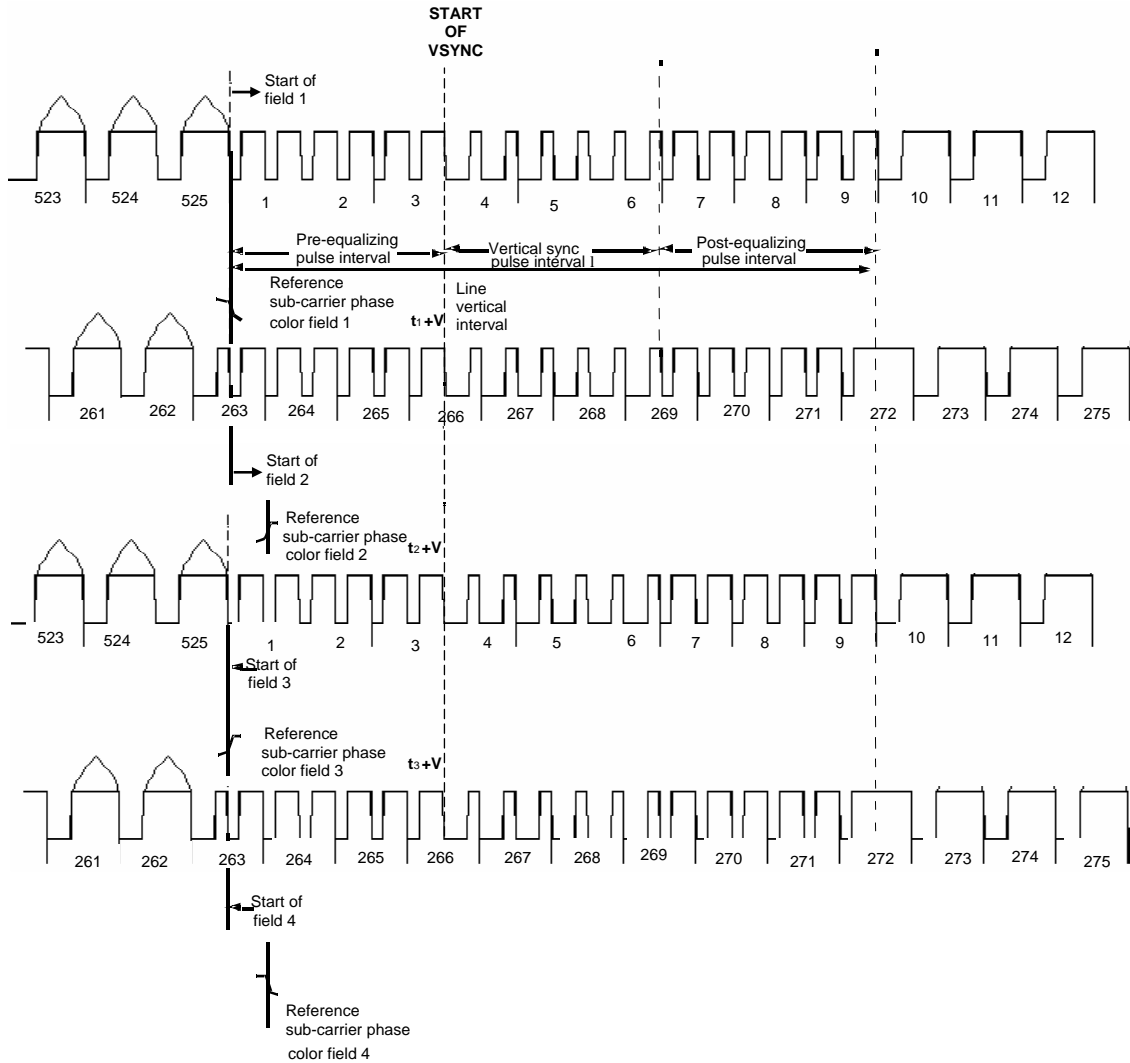

Figure 10: Interlaced NTSC Video Timing



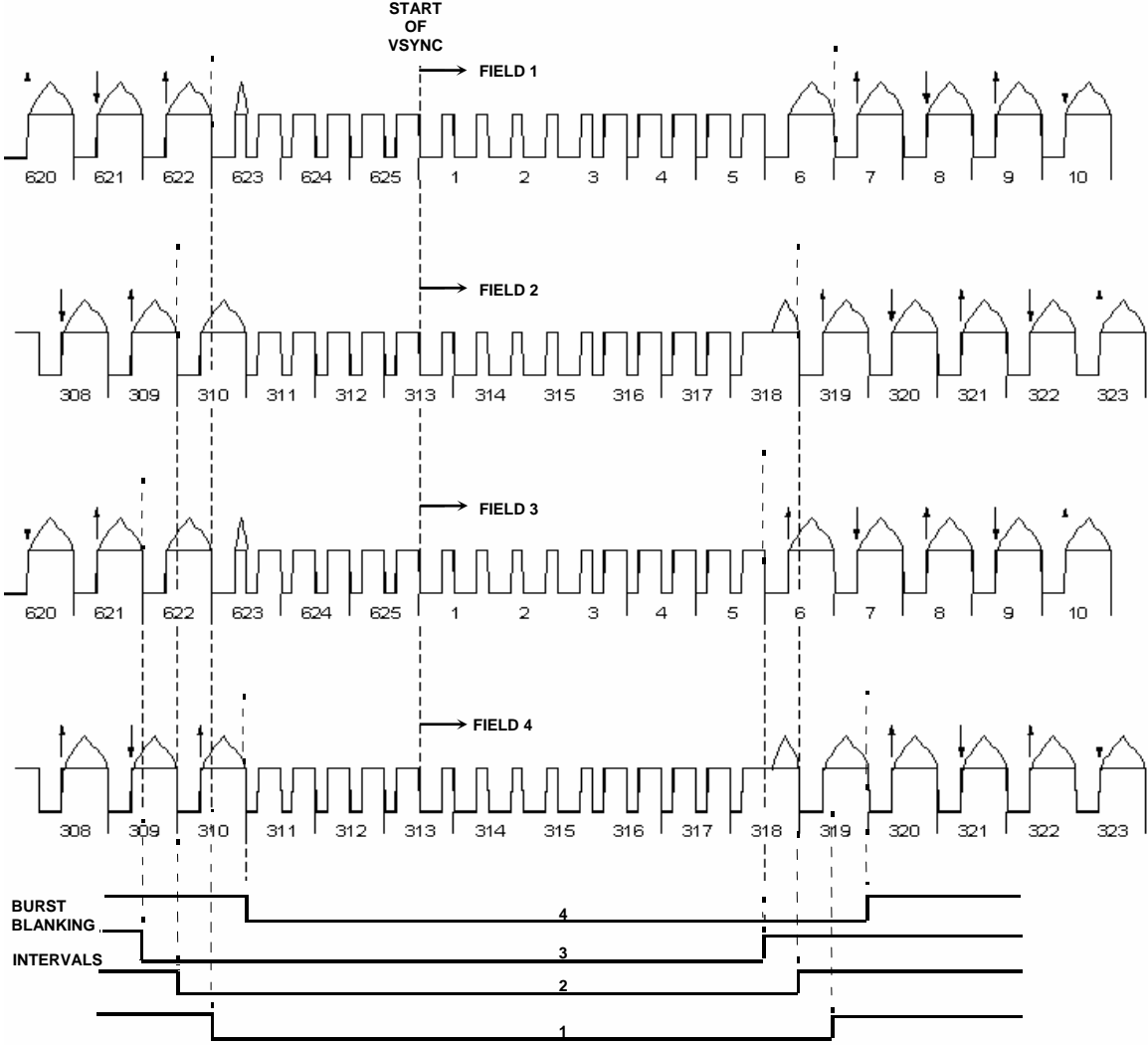
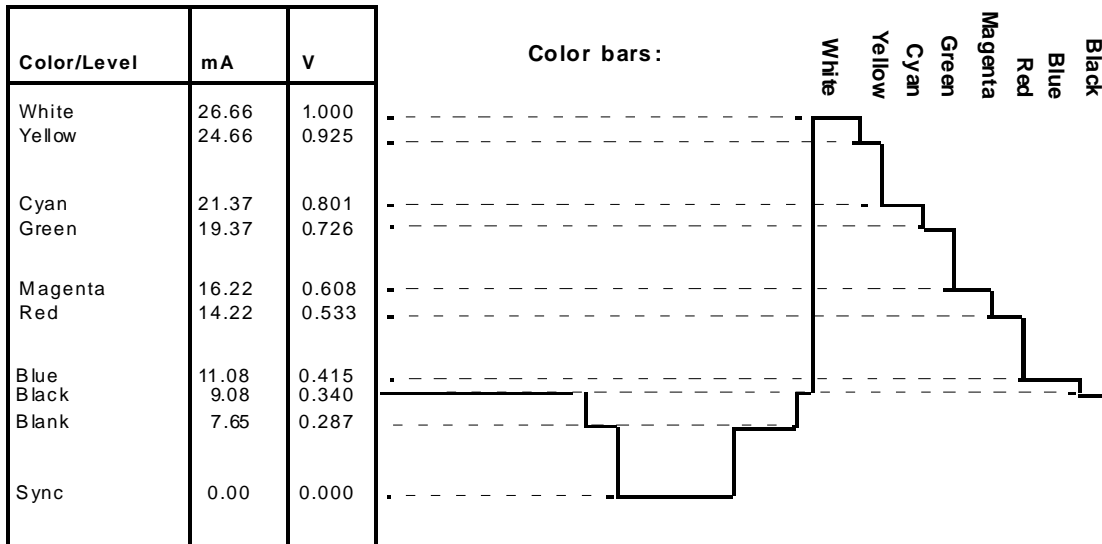
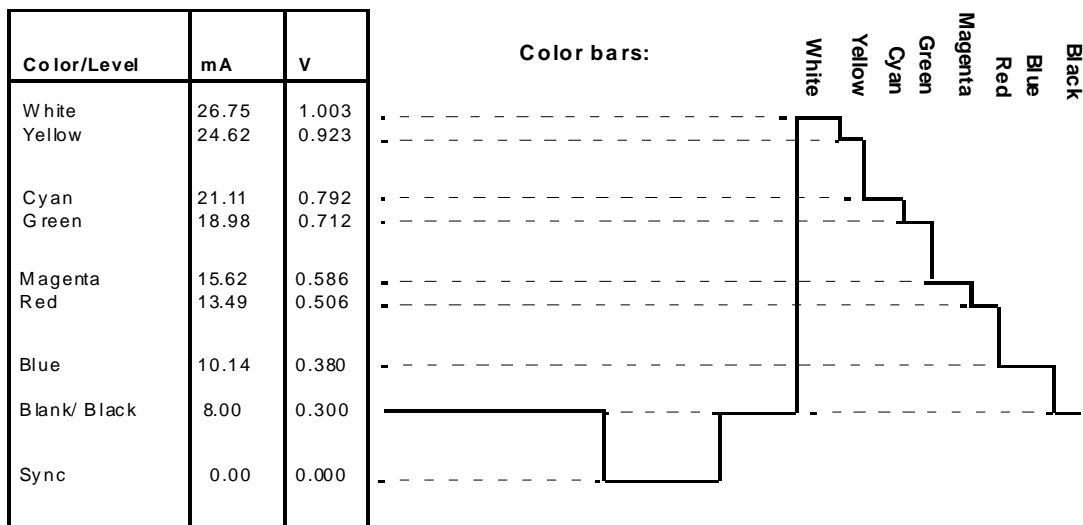

Figure 11: Interlaced PAL Video Timing





**Figure 12: NTSC Y (Luminance) Output Waveform (DACG = 0)**



**Figure 13: PAL Y (Luminance) Video Output Waveform (DACG = 1)**



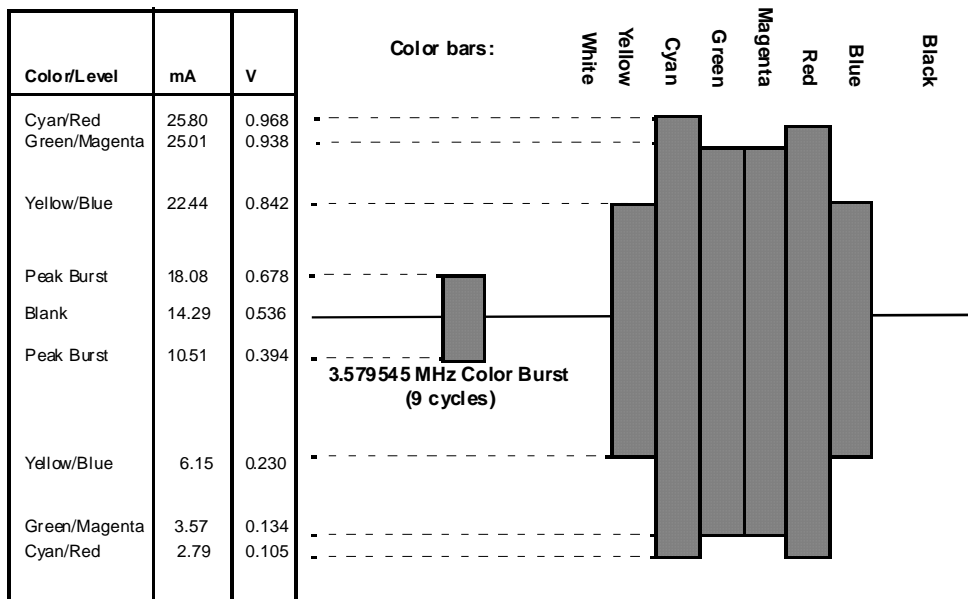

Figure 14: NTSC C (Chrominance) Video Output Waveform (DACG = 0)

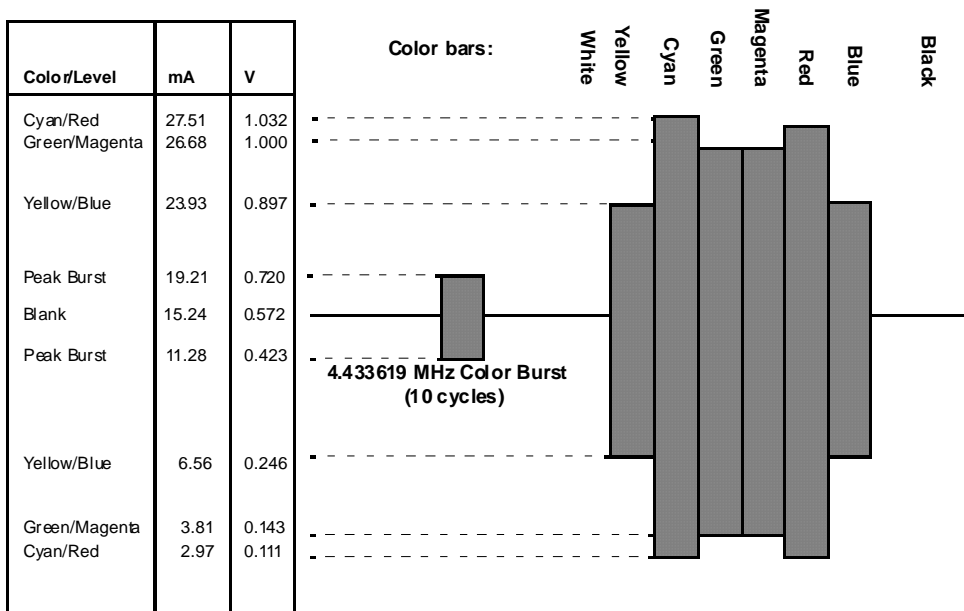

Figure 15: PAL C (Chrominance) Video Output Waveform (DACG = 1)





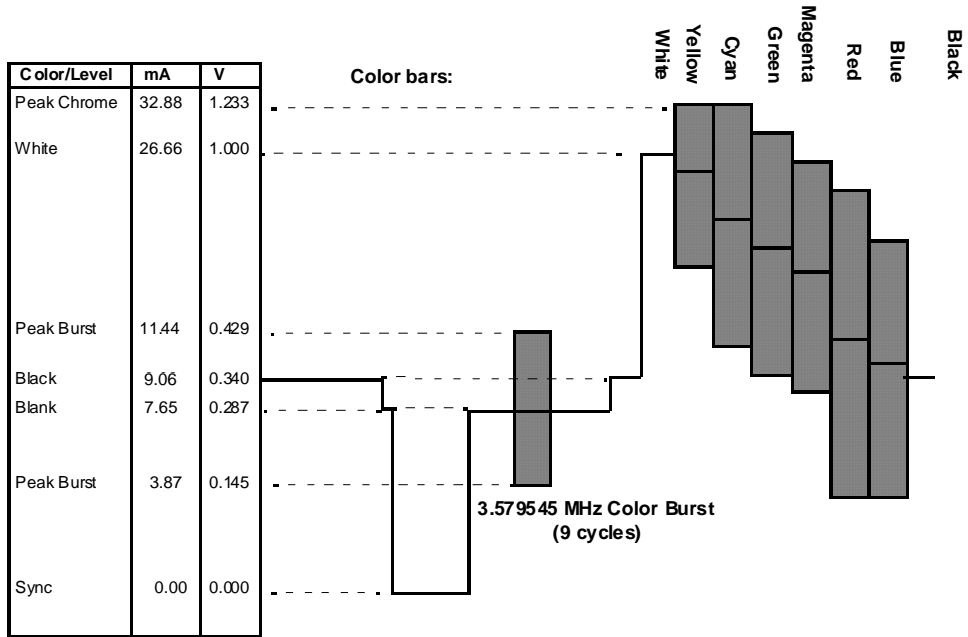

Figure 16: Composite NTSC Video Output Waveform (DACG = 0)

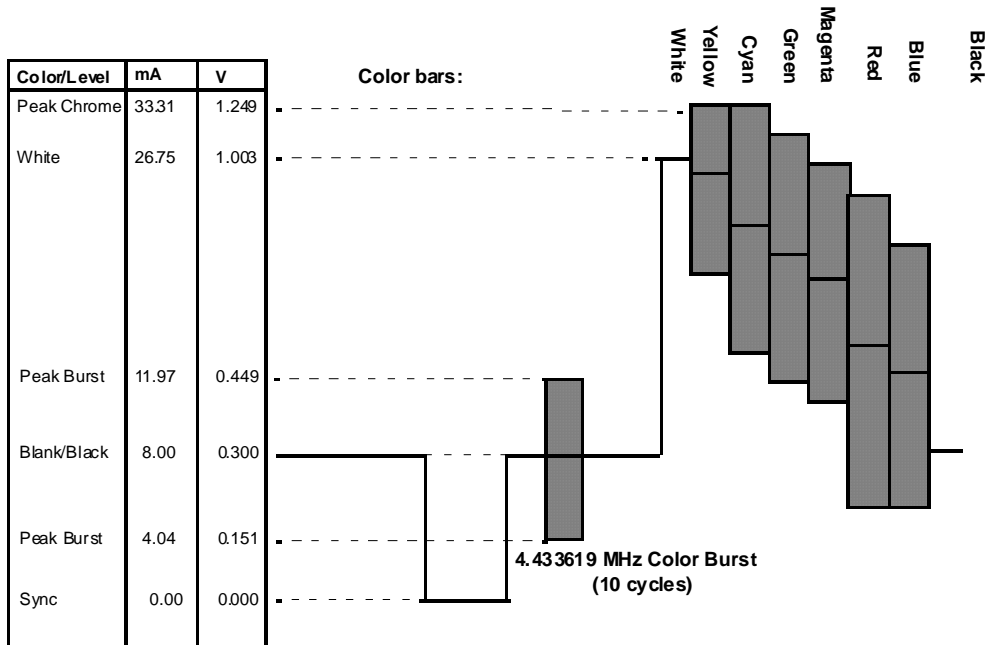

Figure 17: Composite PAL Video Output Waveform (DACG = 1)



**3.3.5 TV Encoder / Bypass RGB / Component Video Outputs**

The four TV encoder DAC outputs in the CH7017/CH7018 can be switched to two sets of output pins DACA[3:0] and DACB[3:0] via video switches. This feature facilitates simple connection to two sets of video connectors as listed in **Table 12**.

**Table 12: TV Output Configurations**

<b>Output DACs</b>	<b>2 RCA + 1 S-Video</b>	<b>SCART</b>
DACA0 (pin 47)	CVBS	B
DACA1 (pin 43)	Y	G
DACA2 (pin 45)	C	R
DACA3 (pin 41)	CVBS	CVBS
	<b>VGA – Bypass RGB</b>	<b>HDTV</b>
DACB0 (pin 46)	B	Pb
DACB1 (pin 42)	G	Y
DACB2 (pin 44)	R	Pr

If the application calls for CVBS/S-video, SCART, RGB and YPrPb to output on the DAC output pins, different reconstruction filters for each type of signal can be implemented on the breakout cables.

The TV Encoder can be bypassed with input data driving the DACs directly. This mode can go to 165 MP/s. The CH7017/CH7018 supports YPrPb output for driving 480i TV sets and SCART RGB for European TV.



**3.4 LVDS-Out**

Multiplexed input data, sync and clock signals from the graphics controllers input to the CH7017/CH7018 through one of the two 12-bit variable voltage input ports, D1[11:0] or D2[11:0]. Non-multiplexed 24-bit input data input through both of the two input ports. For correct LVDS operation, the input data format must be selected to IDFx=0, 1, 2, 3, 5, 8 or 9. Note for 24-bit formats, IDF1 must be set equal to IDF2.

If the two 12-bit input ports are driven from different timing generators then data can be sent to both the LVDS data path and the DACs in the TV data path. The DACs can output these data at 165 M pixels/sec to drive a second CRT monitor.

**3.4.1 Single LVDS Channel Signal Mapping**

**Table 13: Signal Mapping for Single LVDS Channel**

	<b>18-bit</b>	<b>24-bit SPWG</b>	<b>24-bit OpenLDI</b>
LDC[0](1)	R0	R0	R2
LDC[0](2)	R1	R1	R3
LDC[0](3)	R2	R2	R4
LDC[0](4)	R3	R3	R5
LDC[0](5)	R4	R4	R6
LDC[0](6)	R5	R5	R7
LDC[0](7)	G0	G0	G2
LDC[1](1)	G1	G1	G3
LDC[1](2)	G2	G2	G4
LDC[1](3)	G3	G3	G5
LDC[1](4)	G4	G4	G6
LDC[1](5)	G5	G5	G7
LDC[1](6)	B0	B0	B2
LDC[1](7)	B1	B1	B3
LDC[2](1)	B2	B2	B4
LDC[2](2)	B3	B3	B5
LDC[2](3)	B4	B4	B6
LDC[2](4)	B5	B5	B7
LDC[2](5)	HSYNC	HSYNC	HSYNC
LDC[2](6)	VSYNC	VSYNC	VSYNC
LDC[2](7)	DE	DE	DE
LDC[3](1)		R6	R0
LDC[3](2)		R7	R1
LDC[3](3)		G6	G0
LDC[3](4)		G7	G1
LDC[3](5)		B6	B0
LDC[3](6)		B7	B1
LDC[3](7)		RES	RES



**3.4.2 Dual LVDS Channel Signal Mapping**

**Table 14: Signal Mapping for Dual LVDS Channel**

	<b>18-bit</b>	<b>24-bit SPWG</b>	<b>24-bit OpenLDI</b>
LDC[0](1)	Ro0	Ro0	Ro2
LDC[0](2)	Ro1	Ro1	Ro3
LDC[0](3)	Ro2	Ro2	Ro4
LDC[0](4)	Ro3	Ro3	Ro5
LDC[0](5)	Ro4	Ro4	Ro6
LDC[0](6)	Ro5	Ro5	Ro7
LDC[0](7)	Go0	Go0	Go2
LDC[1](1)	Go1	Go1	Go3
LDC[1](2)	Go2	Go2	Go4
LDC[1](3)	Go3	Go3	Go5
LDC[1](4)	Go4	Go4	Go6
LDC[1](5)	Go5	Go5	Go7
LDC[1](6)	Bo0	Bo0	Bo2
LDC[1](7)	Bo1	Bo1	Bo3
LDC[2](1)	Bo2	Bo2	Bo4
LDC[2](2)	Bo3	Bo3	Bo5
LDC[2](3)	Bo4	Bo4	Bo6
LDC[2](4)	Bo5	Bo5	Bo7
LDC[2](5)	HSYNC	HSYNC	HSYNC
LDC[2](6)	VSYNC	VSYNC	VSYNC
LDC[2](7)	DE	DE	DE
LDC[3](1)		Ro6	Ro0
LDC[3](2)		Ro7	Ro1
LDC[3](3)		Go6	Go0
LDC[3](4)		Go7	Go1
LDC[3](5)		Bo6	Bo0
LDC[3](6)		Bo7	Bo1
LDC[3](7)		RES	RES
LDC[4](1)	Re0	Re0	Re2
LDC[4](2)	Re1	Re1	Re3
LDC[4](3)	Re2	Re2	Re4
LDC[4](4)	Re3	Re3	Re5
LDC[4](5)	Re4	Re4	Re6
LDC[4](6)	Re5	Re5	Re7
LDC[4](7)	Ge0	Ge0	Ge2
LDC[5](1)	Ge1	Ge1	Ge3
LDC[5](2)	Ge2	Ge2	Ge4
LDC[5](3)	Ge3	Ge3	Ge5
LDC[5](4)	Ge4	Ge4	Ge6
LDC[5](5)	Ge5	Ge5	Ge7
LDC[5](6)	Be0	Be0	Be2
LDC[5](7)	Be1	Be1	Be3
LDC[6](1)	Be2	Be2	Be4
LDC[6](2)	Be3	Be3	Be5
LDC[6](3)	Be4	Be4	Be6
LDC[6](4)	Be5	Be5	Be7
LDC[6](5)	LCTLE <sup>1</sup>	HSYNC	LCTLE <sup>1</sup>
LDC[6](6)	LCTLF <sup>1</sup>	VSYNC	LCTLF <sup>1</sup>
LDC[6](7)	LA6RL <sup>1</sup>	DE	LA6RL <sup>1</sup>
LDC[7](1)		Re6	Re0
		Re7	Re1



LDC[7](3)		Ge6	Ge0
LDC[7](4)		Ge7	Ge1
LDC[7](5)		Be6	Be0
LDC[7](6)		Be7	Be1
LDC[7](7)		RES	RES

Note:

1. See description for Register 65h.

### 3.4.3 Panel Fitting Up-Scaler

The Up-scaler in CH7017/CH7018 supports the following panel sizes:

**Table 15: Popular Panel Sizes**

UXGA	1600x1200
SXGA+	1400x1050
	1360x1024
SXGA	1280x1024
	1280x960
XGA	1024x768
	1024x600
SVGA	800x600

The CH7017/CH7018 can scale incoming graphics data from lower resolution graphics modes supported by the graphics controller to the native resolution of the supported panels. The up-scaler periodically sends a STALL signal to the graphics controller to halt transmission of one line of active video data. The Up-scaler performs 2D interpolation of the graphics input data and does not change pixel rate between input and output. Maximum pixel rate supported by the Up-scaler is 165 M Pixels / sec. This function must be bypassed if pixel rate exceeds 165Hz, as in the Gang modes (IDFx=8 or 9 running at 330MP/s). During system bootup, the CH7017/CH7018 relies on graphics controller to provide pixel data at the panel native data rate on the correct line and start position such that the WINDOWS logo can be center on the display panel.

Note: The maximum size that can be input to the upscaler is 1400 x 1050.

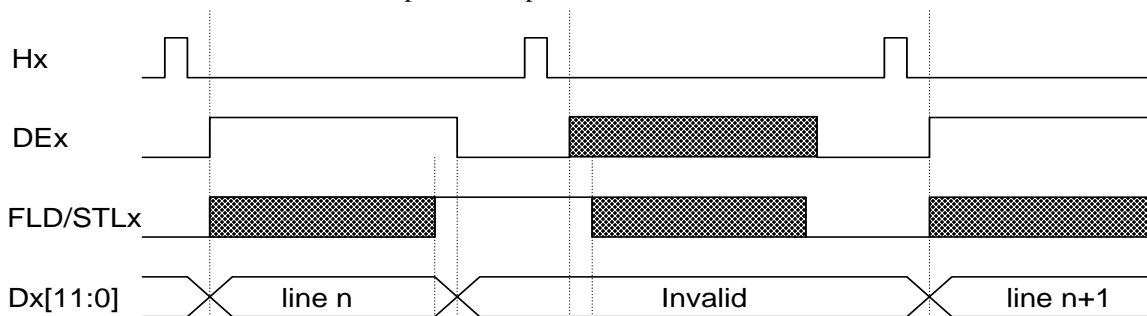

**Figure 18: Stall Signal Timing**

The up-scaler supports the following scaling algorithms:

- Bilinear interpolation
- Programmable non-linear interpolation (default)



3.4.4 Dithering

The dither engine in the CH7017/CH7018 converts 24-bit per pixel to 18-bit per pixel RGB data before sending to the LVDS encoder. The 1D or the 2D dither algorithm can be selected via serial port programming. Maximum pixel rate supported is 165 M Pixels / sec. This function must be bypassed when pixel rate exceeds 165MHz.

3.4.5 Power Sequencing

The CH7017/CH7018 conforms to SPWG’s requirements on power sequencing. The timing specification shown in **Figure 19** is a superset of the requirements dictated by the SPWG specification. The timing parameters can be programmed to different values via the serial port to suit requirements by different panels.

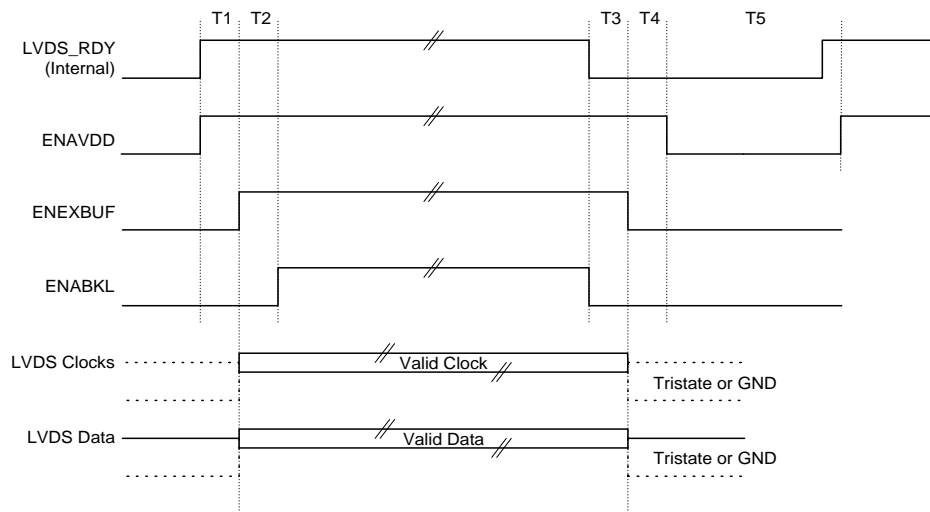

Figure 19: Power Sequencing

Table 16: Power Sequencing

	Range	Increment
T1	1-512 ms	1 ms
T2	2-256 ms	2ms
T3	2-256 ms	2ms
T4	1-512 ms	1 ms
T5	0-1600 ms	50ms

Power-on sequence begins when the LVDS software registers are set properly via serial port and the internal PLL lock detection circuit and the internal Sync detection circuits (See Section 3.4.6) indicate that HSYNC, VSYNC and XCLK are stable. Note that the BKLEN bit (register 66h) must be set in order for the ENABKL signal to be asserted. Power-off sequence begins when any detection circuits indicate an instability in the timing signals (See Section 3.4.6), or through software programming. Once power-off sequence starts, the internal state machine will complete the sequence and power-on sequence is allowed only after T5 is passed.

When the LVDS output clock and data signals become invalid, these outputs are tri-stated or grounded depending on the value of the LODP bit.



3.4.6 Panel Protection

The LCD panel can be damaged if HSYNC is absent from the LVDS link. This situation can happen when there is a catastrophic failure in the PC or the graphics system. The CH7017/CH7018 is designed to prevent damage to the panel under such a failure. If the system fails, the CH7017/CH7018 does not expect any software instruction from the graphics controller to power down the panel. Detection circuits are used to monitor the three timing signals – HSYNC, VSYNC and XCLK. If any one, combination of, or all of these signals becomes unstable, the CH7017/CH7018 will commence Power Down Sequencing according to section 3.4.5. A description of these detection circuits is shown in **Figure 20**.

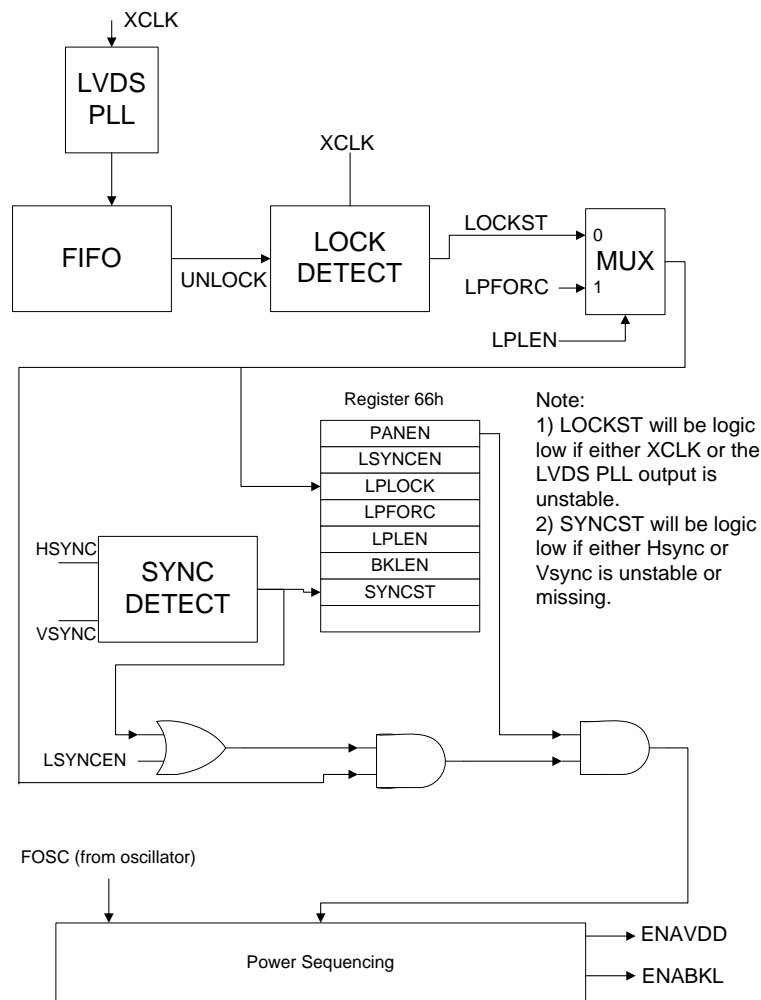

**Figure 20: Detection Circuits for Panel Protection**

A counter is used to count the number of Hsync per frame. If the end counts A, B, and C are the same, CH7017/CH7018 will commence Power-Up Sequence. If Hsync is not stable resulting in different end counts, i.e. A is not equal to B or C, then CH7017/CH7018 will commence Power-Down Sequence. CH7017/CH7018 will also go into Power-Down Sequence if Vsync is missing for 2 frames (D=1), Hsync is missing for 2 lines (E=1), or XCLK is not stable (F=1). The stability of XCLK is determined by the number of PLL unlock signals generated within one frame. This number is programmable via serial port using the BGLMT Register. Under software control, outputs of these detection circuits can be forced to 0 or ignored by the power sequencing circuits.

3.4.7 EMI Reduction Clock

LVDS data path can support a +/- 2.5% EMI reduction clock to reduce EMI emission. The frequency and amplitude of the EMI reduction triangle waveform can be programmed via the serial port.





**3.5 Misc. Functions**

**3.5.1 Voltage Buffering for H and V Syncs**

Two 5-volt non-inverting buffers are included so that the graphics controller can output low-voltage Hsync and Vsync signals to the CH7017/CH7018, which in-turn outputs a 5V sync signal to the CRT monitor. Input threshold voltage for these buffers is programmable via serial port to be equal to  $VREF2/2$ .

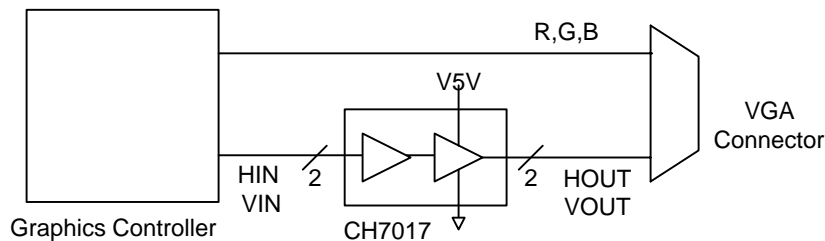

**Figure 21: H and V Sync Buffers**

**3.5.2 Voltage Translation Buffers**

DDC's for VGA and flat panels are typically terminated into 5V. CH7017/CH7018 can translate a low-voltage DDC signal into a 5V DDC signal and vice-versa, eliminating the use of external MOSFET's for such function.

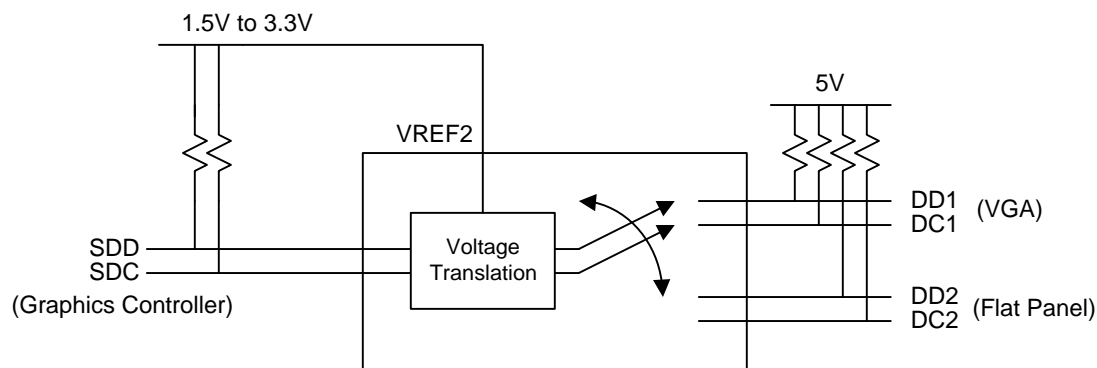

**Figure 22: Voltage Translation Buffers**



**3.6 Power Down**

The CH7017/CH7018 can be powered down under software control to achieve very low standby current. The matrix in the table below shows the function of all the power down control bits for the CH7017/CH7018. For a complete description of each individual bit please refer to the appropriate register description in **Sections 4.1** and **4.2**.

**Table 17: Power Down Control Bits**

<b>T V P D</b>	<b>D A C P D 3</b>	<b>D A C P D 2</b>	<b>D A C P D 1</b>	<b>D A C P D 0</b>	<b>L V S P D</b>	<b>L V S P D B 1</b>	<b>L V S P D B 0</b>	<b>Description</b>
1	X	X	X	X	1	X	X	Full Power Down
0	1	1	1	0	1	X	X	TV path powered up, DAC 0 on, DACs 1, 2, 3 off. LVDS path powered down.
0	0	0	0	1	1	X	X	TV path powered up, DAC 0 off, DACs 1, 2, 3 on. LVDS path powered down.
0	0	0	0	0	1	X	X	TV path powered up, DACs 0, 1, 2, 3 on. LVDS path powered down
1	X	X	X	X	0	0	0	TV path powered down LVDS path powered up. Both channels off..
1	X	X	X	X	0	0	1	TV path powered down. LVDS path powered up. Channel A on, channel B off.
1	X	X	X	X	0	1	0	TV path powered down. LVDS path powered up. Channel A off, channel B on.
1	X	X	X	X	0	1	1	TV path powered down. LVDS path powered up. Channel A on, channel B on.
0	0	0	0	0	0	1	1	TV path powered up, DACs 0, 1, 2, 3 on. LVDS path powered up. Channel A on, channel B on.

Note:

1. X = do not care.
2. TV bit (Register 49h, bit 5) enables the TV path but does not control power down. In order for the TV path to function, TV must be set to 1 and TVPD set to 0.
3. An input channel which is routing data to an inactive path (TV or LVDS) is automatically powered down. For example, if PTSEL[1:0] = 10 (D1 input routed to TV and D2 input routed to LVDS) and if TVPD = 1 (TV path powered down) then data channel D1 is automatically powered down.
4. LDEN[1:0] (Register 73h, bits 4-3) enable the LVDS outputs but do not control power down. In order for an LDVS channel to be active LVDSPD must be set to 0, the channel must be powered up (LODPDBx=1) and enabled (LDENx=1).



## 4.0 Register Control

The CH7017/CH7018 is controlled via a serial control port. The serial bus uses only the SC clock to latch data into Registers, and does not use any internally generated clocks so that the device can be written to in all Power-Down modes. The device should retain all Register values during Power-Down modes.

### 4.1 Non-Macrovision Control Registers Index

The non-Macrovision controls are listed below, divided into four sections: General & Power-Down controls, Input/Output controls, LVDS controls, TV-Out controls.

<b>GENERAL &amp; POWER DOWN CONTROLS</b>		<b>Address</b>
DACPD[3:0]	DAC Power Down	49h
DID[7:0]	Device ID Register	4Bh
LODPDB[1:0]	LVDS Output Driver Power Down control	76h
LSP2	DDC Voltage Translation Buffer select	73h
LVDSPD	LVDS Power Down	63h
PANEN	Panel Enable (0 – begin Power off sequence, 1 Power-on)	66h
RESETIB	Software SPP (serial port) reset	48h
RESETDB	Software datapath reset	48h
STFDEN[1:0]	Enables FLD/STL2 and FLD/STL1 pins	10h
STFDS[1:0]	Controls FLD/STL2 and FLD/STL1 output to VGA controller	60h
TPBLD [6:0]	Timer – Black Light Disable (T3)	69h
TPBLE [6:0]	Timer – Black Light Enable (T2)	68h
TPOFF [8:0]	Timer – Power Off (T4)	69h-6Ah
TPON [8:0]	Timer - Power On (T1)	67h-68h
TPPWD [5:0]	Timer – Power Cycle (T5)	6Bh
TSTP[1:0]	Enable/select test pattern generation (color bar, ramp)	48h
TV	TV Data and Channel select	49h
TVPD	TV Out Power Down	49h
VID[7:0]	Version ID Register	4Ah



<b>INPUT/OUTPUT CONTROLS</b>		<b>Address</b>
BCO[2:0]	Select output signal for BCO pin	22h
BCOEN	Enable BCO Output	22h
BCOP	BCO polarity	22h
BGBST	Bandgap Boost	14h
C3GP[5:0]	GPIO Controls	6Eh, 6Dh
C4GP[5:0]	GPIO Controls	6Bh-6Dh
C5GP[5:0]	GPIO Controls	5Ch, 65h
DACBP	DAC bypass	21h
DACG[1:0]	DAC gain control	21h
DACT[3:0]	DAC termination sense	20h
DES	Decode embedded sync (TV-Out data only)	1Fh
GOENB[5:0]	Direction control for GPIO pins	1Eh, 6Eh
GPIOL[5:0]	Read or Write Data for GPIO pins	1Eh, 6Dh
GPIODR[5:0]	GPIO Driver Type – Open Drain or TTL	6Ch
HPIE	Hot Plug detect interrupt enable	1Eh
HPIR	Hot plug detect interrupt reset	1Eh
HPIS	Hot Plug Interrupt Status	20h
HSPTV	H sync polarity control TV	1Fh
IBS1	Input buffer type select for D1	1Fh
IBS2	Input Buffer type select for D2	1Ch
IDF1[3:0]	Input Data Format for D1	1Fh, 21h
IDF2[3:0]	Input Data Format for D2	53h
MCP1	XCLK Polarity Control for D1	1Ch
MCP2	XCLK Polarity Control for D2	1Ch
PCM	P-Out 1X, 2X select	1Ch
POUTE	P-Out enable	1Eh
POUTP	P-Out clock polarity	1Eh
PTSEL[1:0]	Control data path from D1 and D2 to TV and/or or LVDS blocks	03h
SENSE	TV Sense	20h
SYNCO[1:0]	Enables/selects sync output for Scart and bypass modes	21h
SYOTV	H/V sync direction control (for TV-Out modes only)	1Fh
VSPTV	V sync polarity control for TV	1Fh
XCM1	XCLK 1X / 2X select for D1	1Ch
XCM2	XCLK 1X / 2X select for D2	1Ch
X1CMD[3:0]	Delay adjust between XCLK and D1[11:0]	1Dh
X2CMD[3:0]	Delay adjust between XCLK and D2[11:0]	53h
XOSC[2:0]	Crystal oscillator adjustments	21h, 20h



<b>LVDS CONTROLS</b>		<b>Address</b>
BGLMT[7:0]	Bang Limit control of internal LVDS FIFO over/under run	7Fh
BKLEN	Backlight enable	66h
FRSTB	FIFO Reset Enable	76h
HAPI[10:0]	LVDS Horizontal Active Pixel Input	5Fh - 60h
HAPO[10:0]	LVDS Horizontal Active Pixel Output	62h, 63h
HVEN	HOUT and VOUT level translators enable	64h
LA3RL	OpenLDI Reserved Bit	65h
LA6RL	OpenLDI reserved bit	65h
LA7RL	OpenLDI reserved bit	65h
LCNTLE	OpenLDI Miscellaneous Control Signal	65h
LCNTLF	OpenLDI Miscellaneous Control Signal	65h
LDD	LVDS Dithering Defeat	64h
LDEN[1:0]	LVDS Output Driver enable	73h
LDI	OpenLDI specification selection	64h
LDM2D	LVDS Dithering Mode – 2D	64h
LEOSWP	Odd/even sample output swap on LVDS link	64h
L1ODA[2:0]	LVDS Output Driver Amplitude control for bank 1	74h
L2ODA[2:0]	LVDS Output Driver Amplitude control for bank 2	74h
LODP	LVDS Output Driver Pull-down	74h
LODPE	LVDS Output Driver Pre-emphasis	74h
LODST	LVDS Output Driver Source Termination control	75h
LPCP[2:0]	LVDS PLL Charge pump control	73h
LPFBD[3:0]	LVDS PLL feed back divider controls	71h
LPFFD[1:0]	LVDS PLL feed forward divider controls	71h
LPLF[4:3]	LVDS PLL Loop Filter Capacitor Value	78h
LPLOCK	LVDS PLL Lock – read only Register	66h
LPPD[4:0]	LVDS PLL phase detector trim	78h
LPPDN	LVDS PLL Power Down	76h
LPPRB	LVDS PLL Reset	76h
LPPSD[1:0]	LVDS PLL post scale divider controls	72h
LPVCO[3:0]	LVDS PLL VCO frequency range controls	72h
LSYNCEN	Sync Detection Enable	66h
LVSDC	LVDS Dual Channel Select	64h
SYNCST	HSYNC and VSYNC stability status	66h
USC[39:0]	Up Scaler Coefficients	55h-59h
USHIV [17:0]	Up Scaler Horizontal Increment Value	5Ch-5Eh
US	Upscaler function enable	63h
USVIV [17:0]	Up Scaler Vertical Increment Value	5Ah-5Ch
VALO[10:0]	LVDS Vertical Active Line Output	60h, 61h



<b>TV-OUT CONTROLS</b>		<b>Address</b>
BL[7:0]	TV-Out Black level control	07h
BLKEN	Black Level control Register update	1Dh
CBW	Chroma video bandwidth	02h
CE[2:0]	TV-Out contrast enhancement	08h
CFF[1:0]	Chroma flicker filter setting	01h
CFRB	Chroma sub-carrier free run (bar) control	02h
CIV[25:0]	Calculated sub-carrier increment value read out	10h-13h
CIVC[1:0]	Calculated sub-carrier control (hysteresis)	10h
CIVEN	Calculated sub-carrier enable (was called ACIV)	10h
CVBW	CVBS DAC receives black & white (S-Video) signal	02h
DVS	Defeat External Vsync	47h
FSCI[32:0]	Sub-carrier generation increment value (when CIVEN=0)	0Ch-0Fh
HP[8:0]	TV-Out horizontal position control	05h, 03h
IR[2:0]	Input data resolution (when used for TV-Out)	00h
M/S*	TV-Out PLL reference input control	1Ch
M[8:0]	TV-Out PLL M divider	0Ah, 09h
MEM[2:0]	Memory sense amp reference adjust	09h
N[9:0]	TV-Out PLL N divider	0Bh, 09h
PALN	Select PAL-N when in a CIV mode	10h
PLLCAP	TV-Out PLL Capacitor Control	09h
PLLCPI	TV-Out PLL Charge Pump control settings	09h
SAV[8:0]	Horizontal start of active video	04h, 03h
SR[2:0]	TV-Out scaling ratio	00h
TE[2:0]	Text enhancement	03h
VBID	Vertical blanking interval defeat	02h
VOF[1:0]	TV-Out video format (s-video & composite, YPrPb or RGB)	01h
VOS[1:0]	TV-Out video standard	00h
VP[8:0]	TV-Out vertical position control	06h, 03h
YCV[1:0]	Composite video luma bandwidth	02h
YFFH[1:0]	Luma text enhancement flicker filter setting	01h
YFFL[1:0]	Luma flicker filter setting (incorporates old FLFF control bit)	01h
YSV[1:0]	S-Video luma bandwidth	02h



**Non-Macrovision Control Registers Description**

**Table 18: Non-Macrovision Serial Port Register Map**

Register	Bit 7	Bit 6	Bit 5	Bit 4	Bit 3	Bit 2	Bit 1	Bit 0
00h	IR2	IR1	IR0	VOS1	VOS0	SR2	SR1	SR0
01h	VOF1	VOF0	CFF1	CFF0	YFFH1	YFFH0	YFFL1	YFFL0
02h	VBID	CFRB	CVBW	CBW	YSV1	YSV0	YCV1	YCV0
03h	PTSEL1	PTSEL0	SAV8	HP8	VP8	TE2	TE1	TE0
04h	SAV7	SAV6	SAV5	SAV4	SAV3	SAV2	SAV1	SAV0
05h	HP7	HP6	HP5	HP4	HP3	HP2	HP1	HP0
06h	VP7	VP6	VP5	VP4	VP3	VP2	VP1	VP0
07h	BL7	BL6	BL5	BL4	BL3	BL2	BL1	BL0
08h						CE2	CE1	CE0
09h	MEM2	MEM1	MEM0	N9	N8	M8	PLLCP1	PLLCP0
0Ah	M7	M6	M5	M4	M3	M2	M1	M0
0Bh	N7	N6	N5	N4	N3	N2	N1	N0
0Ch	FSCI31	FSCI30	FSCI29	FSCI28	FSCI27	FSCI26	FSCI25	FSCI24
0Dh	FSCI23	FSCI22	FSCI21	FSCI20	FSCI19	FSCI18	FSCI17	FSCI16
0Eh	FSCI15	FSCI14	FSCI13	FSCI12	FSCI11	FSCI10	FSCI9	FSCI8
0Fh	FSCI7	FSCI6	FSCI5	FSCI4	FSCI3	FSCI2	FSCI1	FSCI0
10h	STFDEN1	STFDEN0	CIV25	CIV24	CIVC1	CIVC0	PALN	CIVEN
11h	CIV23	CIV22	CIV21	CIV20	CIV19	CIV18	CIV17	CIV16
12h	CIV15	CIV14	CIV13	CIV12	CIV11	CIV10	CIV9	CIV8
13h	CIV7	CIV6	CIV5	CIV4	CIV3	CIV2	CIV1	CIV0
14h	BGBST							
1Ch		IBS2	MCP2	XCM2	M/S*	MCP1	PCM	XCM1
1Dh		BLKEN			X1CMD3	X1CMD2	X1CMD1	X1CMD0
1Eh	GOENB1	GOENB0	GPIOL1	GPIOL0	HPIR	HPIE	POUTE	POUTP
1Fh	IBS1	DES	SYOTV	VSPTV	HSPTV	IDF12	IDF11	IDF10
20h		XOSC2	HPI	DACT3	DACT2	DACT1	DACT0	SENSE
21h	XOSC1	XOSC0	IDF13	SYNCO1	SYNCO0	DACG1	DACG0	DACBP
22h	SHF2	SHF1	SHF0	BCOEN	BCOP	BCO2	BCO1	BCO0
47h	DVS							
48h			TVPLL	ResetIB	ResetDB		TSTP1	TSTP0
49h			TV	DACPD3	DACPD2	DACPD1	DACPD0	TVPD
4Ah	VID7	VID6	VID5	VID4	VID3	VID2	VID1	VID0
4Bh	DID7	DID6	DID5	DID4	DID3	DID2	DID1	DID0
53h	X2CMD3	X2CMD2	X2CMD1	X2CMD0	IDF23	IDF22	IDF21	IDF20
55h	USC7	USC6	USC5	USC4	USC3	USC2	USC1	USC0
56h	USC15	USC14	USC13	USC12	USC11	USC10	USC9	USC8
57h	USC23	USC22	USC21	USC20	USC19	USC18	USC17	USC16
58h	USC31	USC30	USC29	USC28	USC27	USC26	USC25	USC24
59h	USC39	USC38	USC37	USC36	USC35	USC34	USC33	USC32
5Ah	USVIV7	USVIV6	USVIV5	USVIV4	USVIV3	USVIV2	USVIV1	USVIV0
5Bh	USVIV15	USVIV14	USVIV13	USVIV12	USVIV11	USVIV10	USVIV8	USVIV8
5Ch	C5GP2	C5GP1	C5GP0		USHIV17	USHIV16	USVIV17	USVIV16
5Dh	USHIV7	USHIV6	USHIV5	USHIV4	USHIV3	USHIV2	USHIV1	USHIV0
5Eh	USHIV15	USHIV14	USHIV13	USHIV12	USHIV11	USHIV10	USHIV9	USHIV8
5Fh	HAPI7	HAPI6	HAPI5	HAPI4	HAPI3	HAPI2	HAPI1	HAPI0
60h	STFDS1	STFDS0	VALO10	VALO9	VALO8	HAPI10	HAPI9	HAPI8
61h	VALO7	VALO6	VALO5	VALO4	VALO3	VALO2	VALO1	VALO0
62h	HAPO7	HAPO6	HAPO5	HAPO4	HAPO3	HAPO2	HAPO1	HAPO0
63h	US	LVDSPD				HAPO10	HAPO9	HAPO8
64h	HVEN		LVDS24	LVDSDC	LDD	LDM2D	LEOSWP	LDI
65h	C5GP5	C5GP4	C5GP3	LA3RL	LA6RL	LA7RL	LCNTLE	LCNTLF
66h		SYNCST	BKLEN	LPLEN	LPFORC	LPLOCK	LSYNCEN	PANEN
67h	TPON7	TPON6	TPON5	TPON4	TPON3	TPON2	TPON1	TPON0
68h	TPON8	TPBLE6	TPBLE5	TPBLE4	TPBLE3	TPBLE2	TPBLE1	TPBLE0
69h	TPOFF8	TPBLD6	TPBLD5	TPBLD4	TPBLD3	TPBLD2	TPBLD1	TPBLD0
		TPOFF6	TPOFF5	TPOFF4	TPOFF3	TPOFF2	TPOFF1	TPOFF0



**CHRONTEL****CH7017/CH7018**

6Bh	C4GP5	C4GP4	TPPWD5	TPPWD4	TPPWD3	TPPWD2	TPPWD1	TPPWD0
6Ch	C4GP3	C4GP2	GPIODR5	GPIODR4	GPIODR3	GPIODR2	GPIODR1	GPIODR0
6Dh	C4GP1	C4GP0	C3GP5	C3GP4	GPIOL5	GPIOL4	GPIOL3	GPIOL2
6Eh	C3GP3	C3GP2	C3GP1	C3GP0	GOENB5	GOENB4	GOENB3	GOENB2
71h			LPFFD1	LPFFD0	LPFBD3	LPFBD2	LPFBD1	LPFBD0
72h			LPPSD1	LPPSD0	LPVCO3	LPVCO2	LPVCO1	LPVCO0
73h	LSP2	DAS1	DAS0	LDEN1	LDEN0	LPCP2	LPCP1	LPCP0
74h	LODP	LODPE	L2ODA2	L2ODA1	L2ODA0	L1ODA2	L1ODA1	L1ODA0
75h	LODST							
76h	FRSTB				LPPDN	LPPRB	LODPDB1	LODPDB0
78h		LPLF4	LPLF3	LPPD4	LPPD3	LPPD2	LPPD1	LPPD0
7Fh	BGLMT7	BGLMT6	BGLMT5	BGLMT4	BGLMT3	BGLMT2	BGLMT1	BGLMT0





4.2 Non-Macrovision Control Registers Description

Display Mode Register

Symbol: DM  
 Address: 00h  
 Bits: 8

BIT:	7	6	5	4	3	2	1	0
SYMBOL:	IR2	IR1	IR0	VOS1	VOS0	SR2	SR1	SR0
TYPE:	R/W	R/W	R/W	R/W	R/W	R/W	R/W	R/W
DEFAULT	0	1	1	0	1	0	1	0

Register DM provides programmable control of the CH7017/CH7018 VGA to TV display mode, including input resolution (IR[2:0]), video output standard (VOS[1:0]), and scaling ratio (SR[2:0]). The mode of operation is determined according to **Table 19** below. Entries in which the output standard is shown as PAL, PAL-B,D,G,H,I,N,N<sub>C</sub> can be supported through proper selection of the chroma sub-carrier. Entries in which the output standard is shown as NTSC, NTSC-M,J and PAL-M can be supported through proper selection of VOS[1:0] and chroma sub-carrier.

Table 19: Display Modes

Mode	IR[2:0]	VOS [1:0]	SR[2:0]	Input Data Format (Active Video)	Total Pixels/Line x Total Lines/Frame	Output Standard [TV Standard]	Scaling	Percent Overscan	Pixel Clock (MHz)
0	000	00	000	512x384	840x500	PAL	5/4	-17	21.000000
1	000	00	001	512x384	840x625	PAL	1/1	-33	26.250000
2	000	01	000	512x384	800x420	NTSC	5/4	0	20.139860
3	000	01	001	512x384	784x525	NTSC	1/1	-20	24.671329
4	001	00	000	720x400	1125x500	PAL	5/4	-13	28.125000
5	001	00	001	720x400	1152x625	PAL	1/1	-30	36.000000
6	001	01	000	720x400	945x420	NTSC	5/4	+4	23.790210
7	001	01	001	720x400	936x525	NTSC	1/1	-16	29.454545
8	010	00	000	640x400	1000x500	PAL	5/4	-13	25.000000
9	010	00	001	640x400	1008x625	PAL	1/1	-30	31.500000
10	010	01	000	640x400	840x420	NTSC	5/4	+4	21.146854
11	010	01	001	640x400	832x525	NTSC	1/1	-17	26.181819
12	010	01	010	640x400	840x600	NTSC	7/8	-27	30.209791
13	011	00	000	640x480	840x500	PAL	5/4	+4	21.000000
14	011	00	001	640x480	840x625	PAL	1/1	-17	26.250000
15	011	00	011	640x480	840x750	PAL	5/6	-30	31.500000
16	011	01	001	640x480	784x525	NTSC	1/1	0	24.671329
17	011	01	010	640x480	784x600	NTSC	7/8	-13	28.195805
18	011	01	011	640x480	800x630	NTSC	5/6	-18	30.209790
19	100	01	001	720x480	882x525	NTSC	1/1	0	27.755245
20	100	01	010	720x480	882x600	NTSC	7/8	-13	31.720280
21	100	01	011	720x480	900x630	NTSC	5/6	-18	33.986015
22	101	00	001	720x576	882x625	PAL	1/1	0	27.562500
23	101	00	011	720x576	900x750	PAL	5/6	-18	33.750000
24	101	00	100	720x576	900x875	PAL	5/7	-30	39.375000
25	110	00	001	800x600	944x625	PAL	1/1	+4	29.500000
26	110	00	011	800x600	960x750	PAL	5/6	-14	36.000000
27	110	00	100	800x600	960x875	PAL	5/7	-27	42.000000
28	110	01	110	800x600	1040x700	NTSC	3/4	-6	43.636364
29	110	01	111	800x600	1064x750	NTSC	7/10	-14	47.832169
		01	101	800x600	1040x840	NTSC	5/8	-22	52.363637



31	111	00	100	1024x768	1400x875	PAL	5/7	-4	61.250000
32	111	00	101	1024x768	1400x1000	PAL	5/8	-16	70.000000
33	111	00	110	1024x768	1400x1125	PAL	5/9	-25	78.750000
34	111	01	101	1024x768	1160x840	NTSC	5/8	0	58.405595
35	111	01	110	1024x768	1160x945	NTSC	5/9	-10	65.706295
36	111	01	111	1024x768	1168x1050	NTSC	1 / 2	-20	73.510491
37 <sup>1</sup>	101	00	000	720x576	864x625	PAL	1/1	0	13.500000
38 <sup>1</sup>	100	01	000	720x480	858x525	NTSC	1/1	0	13.500000
39	001	01	111	720x400	900x441	NTSC	25/21	-1	23.790210
40	010	01	111	640x400	800x441	NTSC	25/21	-1	21.146854
41	011	00	111	640x480	800x525	PAL	25/21	-1	21.000000
42	100	01	101	720x480	880x525	NTSC	1/1	0	27.692308
43	100	01	110	720x480	784x600	NTSC	7/8	-13	28.195805
44	100	01	111	720x480	880x630	NTSC	5/6	-18	33.230770
45	101	00	101	720x576	888x625	PAL	1/1	0	27.750000
46	101	00	110	720x576	880x750	PAL	5/6	-18	33.000000
47	101	00	111	720x576	880x875	PAL	5/7	-30	38.500000

<sup>1</sup> These DVD modes operate with interlaced input. Scan conversion and flicker filter are bypassed.

**Table 20: Video Output Standard Selection**

VOS[1:0]	00	01	10	11
Output Format	PAL	NTSC	PAL-M	NTSC-J

**Flicker Filter Register**

**Symbol:** FF  
**Address:** 01h  
**Bits:** 8

BIT:	7	6	5	4	3	2	1	0
SYMBOL:	VOF1	VOF0	CFF1	CFF0	YFFH1	YFFH0	YFFL1	YFFL0
TYPE:	R/W	R/W	R/W	R/W	R/W	R/W	R/W	R/W
DEFAULT:	0	1	1	0	0	1	1	1

YFFL[1:0] (bits 1-0) of Register FF control the filter used in the scaling and flicker reduction block applied to the non-text portion (low frequency) of the luminance signal as shown in **Table 21** below.

YFFH[1:0] (bits 3-2) of Register FF control the filter used in the scaling and flicker reduction block applied to the text portion (high frequency) of the luminance signal as shown in **Table 21** below.

**Table 21: Luma Flicker Filter Control**

Scaling Ratio	YFFH and YFFL Flicker Filter Settings (lines)			
	00	01	10	11
5/4	2	3	3	3
1/1, 7/8, 5/6, 3/4, 5/7, 7/10	2	3	4	5
5/8	2	3	4	6
25/21	2	3	6	6
5/9	3	4	5	6
1/2	3	5	5	7



CFF[1:0] (bits 5-4) of **Register FF** control the filter used in the scaling and flicker reduction block applied to the chrominance signal as shown in **Table 22** below. A setting of ‘11’ applies a dot crawl reduction filter which can reduce the ‘hanging dots’ effect of an NTSC composite video signal when displayed on a TV with a comb filter.

**Table 22: Chroma Flicker Filter Control**

Scaling Ratio	CFF Flicker Filter Settings (lines)			
	00	01	10	11
5/4	2	3	3	3
1/1, 7/8, 5/6, 3/4, 5/7, 7/10	2	3	4	5
5/8	2	3	4	5
25/21	2	3	4	6
5/9	3	4	5	6
1/2	3	5	5	7

VOF[1:0] (bits 7-6) of Register FF control the video output format. Must be set per the table below:

**Table 23: TV Output Configurations**

VOF1	VOF0	TV Output Configuration
0	0	YCrCb
0	1	Composite, S-Video
1	0	YPrPb (480I component HDTV set)
1	1	SCART + Composite

For the TV out DAC by-pass for RGB out, refer to DACBP (bit0 of Register 21h). Refer to **Table 12** in **Section 3.3.5** for TV Output DAC configuration.

**Video Bandwidth Register**

**Symbol: VBW**  
**Address: 02h**  
**Bits: 8**

BIT:	7	6	5	4	3	2	1	0
SYMBOL:	VBID	CFRB	CVBW	CBW	YSV1	YSV0	YCV1	YCV0
TYPE:	R/W	R/W	R/W	R/W	R/W	R/W	R/W	R/W
DEFAULT:	1	0	0	1	1	1	1	0

YCV[1:0] (bits 1-0) of Register VBW control the filter used to limit the bandwidth of the luma signal in the CVBS output signal. A table of –3dB bandwidth values is given in **Table 24** below.

YSV[1:0] (bits 3-2) of Register VBW control the filter used to limit the bandwidth of the luma signal in the S-Video output signal. A table of –3dB bandwidth values is given in **Table 24** below.

CBW (bit 4) of Register VBW controls the filter used to limit the bandwidth of the chroma signal in the CVBS and S-Video output signals. A table of –3dB bandwidth values is given in **Table 24** below.



**Table 24: Video Bandwidth**

Mode	CBW		YSV[1:0] and YCV[1:0]			
	0	1	00	01	10	11
0	0.620	0.856	2.300	2.690	3.540	5.880
1	0.775	1.070	2.880	3.360	4.430	7.350
2	0.529	0.730	1.960	2.290	3.020	5.010
3	0.648	0.894	2.410	2.810	3.700	6.140
4	0.831	1.150	3.080	3.600	4.750	7.870
5	1.060	1.470	3.950	4.610	6.080	10.100
6	0.703	0.970	2.610	3.040	4.010	6.660
7	0.870	1.200	3.230	3.770	4.970	8.240
8	0.738	1.020	2.740	3.200	4.220	7.000
9	0.930	1.280	3.460	4.030	5.320	8.820
10	0.624	0.862	2.320	2.710	3.570	5.920
11	0.773	1.070	2.870	3.350	4.420	7.330
12	0.892	1.230	3.310	3.870	5.100	8.450
13	0.620	0.856	2.300	2.690	3.540	5.880
14	0.775	1.070	2.880	3.360	4.430	7.350
15	0.930	1.280	3.460	4.030	5.320	8.820
16	0.648	0.894	2.410	2.810	3.700	6.140
17	0.740	1.020	2.750	3.210	4.230	7.010
18	0.793	1.100	2.950	3.440	4.530	7.510
19	0.729	1.010	2.710	3.160	4.160	6.900
20	0.833	1.150	3.090	3.610	4.760	7.890
21	0.892	1.230	3.310	3.870	5.100	8.450
22	0.724	0.999	2.690	3.140	4.130	6.860
23	0.886	1.220	3.290	3.840	5.060	8.400
24	1.030	1.430	3.840	4.480	5.910	9.790
25	0.774	1.070	2.880	3.360	4.430	7.340
26	0.945	1.310	3.510	4.100	5.400	8.960
27	1.100	1.520	4.100	4.780	6.300	10.400
28	0.859	1.190	3.190	3.720	4.910	8.140
29	0.942	1.300	3.500	4.080	5.380	8.920
30	1.030	1.420	3.830	4.470	5.890	9.770
31	0.804	1.110	2.990	3.480	4.590	7.620
32	0.919	1.270	3.410	3.980	5.250	8.710
33	1.030	1.430	3.840	4.480	5.910	9.790
34	0.767	1.060	2.850	3.320	4.380	7.260
35	0.862	1.190	3.200	3.740	4.930	8.170
36	0.965	1.330	3.580	4.180	5.510	9.140
37	0.709	0.979	2.630	3.070	4.050	6.720
38	0.466	0.643	1.730	2.020	2.660	4.410
39	0.703	0.970	2.610	3.040	4.010	6.660
40	0.624	0.862	2.320	2.710	3.570	5.920
41	0.620	0.856	2.300	2.690	3.540	5.880
42	0.727	1.003	2.696	3.153	4.149	6.892
43	0.833	1.150	3.090	3.610	4.760	7.890
44	0.892	1.231	3.309	3.870	5.093	8.459
45	0.728	1.005	2.702	3.160	4.158	6.907
46	0.866	1.196	3.213	3.757	4.945	8.213
47	1.010	1.395	3.748	4.384	5.769	9.582



CVBW (bit 5) of Register VBW controls the chroma component of the CVBS signal. CVBW = ‘0’ disables the chroma signal being added to the CVBS signal, CVBW = ‘1’ enables the chroma signal being added to the CVBS signal.

CFRB (bit 6) of Register VBW controls whether the chroma sub-carrier free-runs, or is locked to the video signal. A ‘1’ causes the sub-carrier to lock to the TV vertical rate, and should be used when the CIVEN bit (Register 10h) is set to ‘0’. A ‘0’ causes the sub-carrier to free-run, and should be used when the CIVEN bit is set to ‘1’.

VBID (bit 7) of Register VBW controls the vertical blanking interval defeat function. A ‘1’ in this Register location forces the flicker filter to minimum filtering during the vertical blanking interval. A ‘0’ in this location causes the flicker filter to remain at the same setting inside and outside of the vertical blanking interval.

**Text Enhancement Register**

**Symbol: TE**  
**Address: 03h**  
**Bits: 8**

BIT:	7	6	5	4	3	2	1	0
SYMBOL:	PTSEL1	PTSEL0	SAV8	HP8	VP8	TE2	TE1	TE0
TYPE:	R/W	R/W	R/W	R/W	R/W	R/W	R/W	R/W
DEFAULT:	1	0	0	0	0	1	0	1

TE[2:0] (bits 2-0) of Register TE control the text enhancement circuitry within the CH7017/CH7018. A value of ‘000’ minimizes the enhancement feature, while a value of ‘111’ maximizes the enhancement.

SAV8, HP8 and VP8 (bits 5-3) of Register TE contain the MSB values for the start of active video, horizontal position and vertical position controls. They are described in detail in the SAV (address 04h), HP (address 05h) and VP (address 06h) Register descriptions.

PTSEL[1:0] (bits 7-6) of Register TE control the data path from D1[11:0] and D2[11:0] inputs to internal TV and LVDS blocks. These bits allow one to swap the input data paths to internal TV or LVDS blocks. The default setting which routes D1 input to TV block and D2 input to LVDS block is recommended.

PTSEL1	PTSEL0	Description
0	0	D1 input is routed to both internal TV and LVDS block
0	1	D1 input is routed to LVDS and D2 input is routed to TV block
1	0	D1 input is routed to TV and D2 input is routed to LVDS block
1	1	D2 input is routed to both internal TV and LVDS block

**Start of Active Video Register**

**Symbol: SAV**  
**Address: 04h**  
**Bits: 8**

BIT:	7	6	5	4	3	2	1	0
SYMBOL:	SAV7	SAV6	SAV5	SAV4	SAV3	SAV2	SAV1	SAV0
TYPE:	R/W	R/W	R/W	R/W	R/W	R/W	R/W	R/W
DEFAULT:	0	1	0	1	0	0	0	0



Register SAV controls the delay, in pixel increments, from leading edge of horizontal sync to start of active video. The entire bit field SAV[8:0] is comprised of this Register SAV[7:0], plus SAV[8] contained in the Text Enhancement Register (03h, bit 5). This is decoded as a whole number of pixels, which can be set anywhere between 0 and 511 pixels. Therefore, in any 2X clock mode, the number of 2X clocks from the leading edge of Hsync to the first active data must be a multiple of two clocks.

**Horizontal Position Register**

**Symbol: HP**  
**Address: 05h**  
**Bits: 8**

BIT:	7	6	5	4	3	2	1	0
SYMBOL:	HP7	HP6	HP5	HP4	HP3	HP2	HP1	HP0
TYPE:	R/W	R/W	R/W	R/W	R/W	R/W	R/W	R/W
DEFAULT:	0	1	0	1	0	0	0	0

Register HP is used to shift the displayed TV image in a horizontal direction (left or right) to achieve a horizontally centered image on screen. The entire bit field, HP[8:0], is comprised of this Register HP[7:0] plus HP[8] contained in the Text Enhancement Register (03h, bit 4). Increasing values move the displayed image position right, and decreasing values move the image position left.

**Vertical Position Register**

**Symbol: VP**  
**Address: 06h**  
**Bits: 8**

BIT:	7	6	5	4	3	2	1	0
SYMBOL:	VP7	VP6	VP5	VP4	VP3	VP2	VP1	VP0
TYPE:	R/W	R/W	R/W	R/W	R/W	R/W	R/W	R/W
DEFAULT:	0	0	0	0	0	0	0	0

Register VP is used to shift the displayed TV image in a vertical direction (up or down) to achieve a vertically centered image on screen. The entire bit field, VP[8:0], is comprised of this Register VP[7:0] plus VP[8] contained in the Text Enhancement Register (03h, bit 3). The value represents the TV line number (relative to the VGA vertical sync) used to initiate the generation and insertion of the TV vertical interval (i.e. the first sequence of equalizing pulses). Increasing values delay the output of the TV vertical sync, causing the image position to move up on the TV screen. Decreasing values, therefore, move the image position DOWN. Each increment moves the image position by one TV line (approximately 2 input lines). The maximum value that should be programmed into VP[8:0] is the number of TV lines per field minus one half (262 or 312). When panning the image up, the number should be increased until (TVLPF-1/2) is reached, the next step should be to reset the Register to zero. When panning the image down the screen, decrement the VP[8:0] value until the value zero is reached. The next step should set the Register to TVLPF-1/2, and then decrement for further changes.



**Black Level Register**

**Symbol:** BL  
**Address:** 07h  
**Bits:** 8

BIT:	7	6	5	4	3	2	1	0
SYMBOL:	BL7	BL6	BL5	BL4	BL3	BL2	BL1	BL0
TYPE:	R/W	R/W	R/W	R/W	R/W	R/W	R/W	R/W
DEFAULT:	1	0	0	0	0	0	1	1

Register BL controls the black level. The luminance data is added to this black level, which must be set between 65 and 170. When the input data format is 0 through 3 or 5 the default values are 131 for NTSC and PAL-M, 110 for PAL and 102 for NTSC-J. When the input data format is 4, 6 or 7 the default values are 112 for NTSC and PAL-M, 94 for PAL and 88 for NTSC-J and YPrPb.

**Contrast Enhancement Register**

**Symbol:** CE  
**Address:** 08h  
**Bits:** 3

BIT:	7	6	5	4	3	2	1	0
SYMBOL:	Reserved	Reserved	Reserved	Reserved	Reserved	CE2	CE1	CE0
TYPE:	R/W	R/W	R/W	R/W	R/W	R/W	R/W	R/W
DEFAULT:	0	0	0	0	0	0	1	1

CE[2:0] (bits 2-0) of Register CE control the contrast enhancement feature of the CH7017/CH7018, according to **Figure 23** below. A setting of '0' results in reduced contrast, a setting of '1' leaves the image contrast unchanged, and values beyond '1' result in increased contrast. [Note: The straight line denotes  $Y_{out} = Y_{in}$  and therefore no enhancement.]

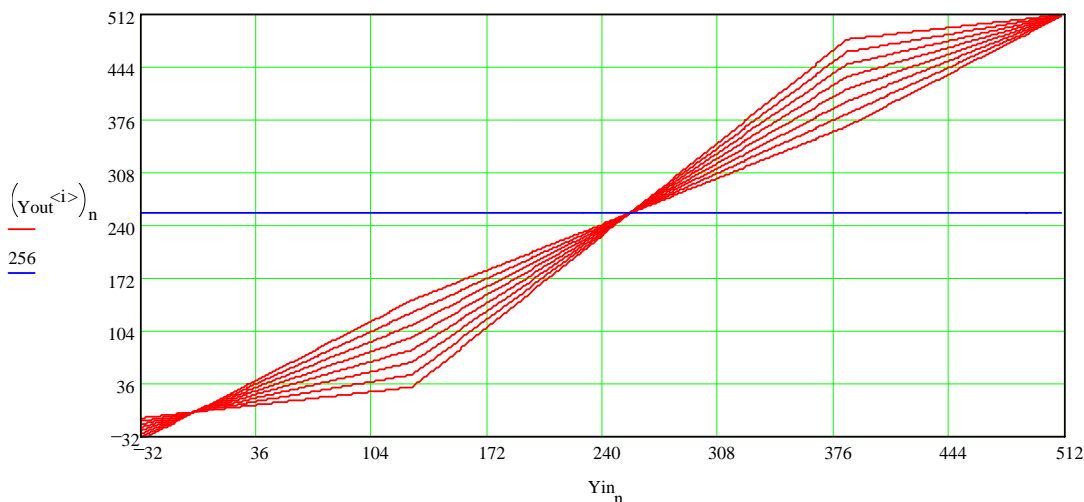

**Figure 23: Contrast Enhancement of the CH7017/CH7018**



**TV PLL Control Register**

**Symbol:** TPC  
**Address:** 09h  
**Bits:** 8

BIT:	7	6	5	4	3	2	1	0
SYMBOL:	MEM2	MEM1	MEM0	N9	N8	M8	PLLCPI	PLLCAP
TYPE:	R/W	R/W	R/W	R/W	R/W	R/W	R/W	R/W
DEFAULT:	1	0	0	0	0	0	0	0

PLLCAP (bit 0) of Register TPC controls the TV PLL loop filter capacitor. A recommended listing of PLLCAP settings versus mode is given in **Table 25** below.

**Table 25: PLLCAP setting vs. Display Mode**

Mode	PLLCAP Value	Mode	PLLCAP Value
0	1	24	1
1	1	25	0
2	0	26	1
3	0	27	1
4	1	28	1
5	1	29	0
6	0	30	1
7	1	31	1
8	0	32	1
9	1	33	1
10	0	34	0
11	1	35	0
12	0	36	0
13	1	37	1
14	1	38	1
15	1	39	0
16	0	40	0
17	0	41	1
18	0	42	0
19	0	43	0
20	0	44	0
21	0	45	0
22	1	46	0
23	1	47	1

PLLCPI (bit 1) of Register TPC should be left at the default value.

M8 and N[9:8] (bits 4-2) of Register TPC contain the MSB values for the TV PLL divider ratio's. These controls are described in detail in the PLLM (address 0Ah) and PLLN (address 0Bh) Register descriptions.

MEM[0] (bit 5) of Register TPC controls the input latch bias current level. The default value is recommended.

MEM[2:1] (bits 7-6) of Register TPC control the memory sense amp reference level. The default value is recommended.





**TV PLL M Value Register**

**Symbol:** PLLM  
**Address:** 0Ah  
**Bits:** 8

BIT:	7	6	5	4	3	2	1	0
SYMBOL:	M7	M6	M5	M4	M3	M2	M1	M0
TYPE:	R/W	R/W	R/W	R/W	R/W	R/W	R/W	R/W
DEFAULT:	0	0	1	1	1	1	1	1

Register PLLM controls the division factor applied to the 14.31818MHz frequency reference clock before it is input to the TV PLL phase detector when the CH7017/CH7018 is operating in clock master mode. The entire bit field, M[8:0], is comprised of this Register M[7:0] plus M[8] contained in the TV PLL Control Register (09h, bit2). In slave mode, an external pixel clock is used instead of the 14.31818MHz frequency reference, but the division factor is also controlled by M[8:0]. In slave mode, the value of ‘M’ is internally set to 1. A table of values (**Table 26**) versus display mode is given following the PLLN Register description.

**TV PLL N Value Register**

**Symbol:** PLLN  
**Address:** 0Bh  
**Bits:** 8

BIT:	7	6	5	4	3	2	1	0
SYMBOL:	N7	N6	N5	N4	N3	N2	N1	N0
TYPE:	R/W	R/W	R/W	R/W	R/W	R/W	R/W	R/W
DEFAULT:	0	1	1	1	1	1	1	0

Register PLLN controls the division factor applied to the VCO output before being applied to the PLL phase detector, when the CH7017/CH7018 is operating in clock master mode. The entire bit field, N[9:0], is comprised of this Register N[7:0] plus N[9:8] contained in the TV PLL Control Register (09h, bits 3 and 4). In slave mode, the value of ‘N’ is internally set to 1. The pixel clock generated in clock master modes is calculated according to the equation  $F_{pixel} = F_{ref} * [(N+2) / (M+2)]$ . When using a 14.31818MHz frequency reference, the required M and N values for each mode are shown in **Table 26** below:

**Table 26: TV PLL M and N values vs. Display Mode**

Mode	VGA Resolution, TV Standard, Scaling Ratio	N 10-bits (dec)	N 10-bits (hex)	M 9-bits (dec)	M 9-bits (hex)
0	512x384, PAL, 5:4	20	0x14	13	0x0D
1	512x384, PAL, 1:1	9	0x09	4	0x04
2	512x384, NTSC, 5:4	126	0x7E	89	0x59
3	512x384, NTSC, 1:1	110	0x6E	63	0x3F
4	720x400, PAL, 5:4	53	0x35	26	0x1A
5	720x400, PAL, 1:1	86	0x56	33	0x21
6	720x400, NTSC, 5:4	106	0x6A	63	0x3F
7	720x400, NTSC, 1:1	70	0x46	33	0x21
8	640x400, PAL, 5:4	108	0x6C	61	0x3D



Mode	VGA Resolution, TV Standard, Scaling Ratio	N 10-bits (dec)	N 10-bits (hex)	M 9-bits (dec)	M 9-bits (hex)
9	640x400, PAL, 1:1	9	0x09	3	0x03
10	640x400, NTSC, 5:4	94	0x5E	63	0x3F
11	640x400, NTSC, 1:1	62	0x3E	33	0x21
12	640x400, NTSC, 7:8	190	0xBE	89	0x59
13	640x480, PAL, 5:4	20	0x14	13	0x0D
14	640x480, PAL, 1:1	9	0x09	4	0x04
15	640x480, PAL, 5:6	9	0x09	3	0x03
16	640x480, NTSC, 1:1	110	0x6E	63	0x3F
17	640x480, NTSC, 7:8	126	0x7E	63	0x3F
18	640x480, NTSC, 5:6	190	0xBE	89	0x59
19	720x480, NTSC, 1:1	124	0x7C	63	0x3F
20	720x480, NTSC, 7:8	142	0x8E	63	0x3F
21	720x480, NTSC, 5:6	214	0xD6	89	0x59
22	720x480, PAL, 1:1	75	0x4B	38	0x26
23	720x480, PAL, 5:6	31	0x1F	12	0x0C
24	720x480, PAL, 5:7	9	0x09	2	0x02
25	800x600, PAL, 1:1	647	0x287	313	0x139
26	800x600, PAL, 5:6	86	0x56	33	0x21
27	800x600, PAL, 5:7	42	0x2A	13	0x0D
28	800x600, NTSC, 3:4	62	0x3E	19	0x13
29	800x600, NTSC, 7:10	302	0x12E	89	0x59
30	800x600, NTSC, 5/8	126	0x7E	33	0x21
31	1024x768, PAL, 5:7	75	0x4B	16	0x10
32	1024x768, PAL, 5:8	42	0x2A	7	0x07
33	1024x768, PAL, 5:9	20	0x14	2	0x02
34	1024x768, NTSC, 5:8	565	0x235	137	0x89
35	1024x768, NTSC, 5:9	333	0x14D	71	0x47
36	1024x768, NTSC, 1:2	917	0x395	177	0xB1
37	720x576, PAL, 1:1	31	0x1F	33	0x21
38	720x480, NTSC, 1:1	31	0x1F	33	0x21
39	720x480, NTSC, 1:1	106	0x6A	63	0x3F
40	640x400, NTSC, 25:21	94	0x5E	63	0x3F
41	640x480, PAL, 25:21	20	0x14	13	0x0D
42	720x480, NTSC, 1:1	174	0xAE	89	0x59
43	720x480, NTSC, 7:8	126	0x7E	63	0x3F
44	720x480, NTSC, 5:6	309	0x135	132	0x84
45	720x576, PAL, 1:1	405	0x195	208	0xD0
46	720x576, PAL, 5:6	240	0xF0	103	0x67
47	720x576, PAL, 5:7	119	0x77	43	0x2B



**Sub-carrier Value Register**

**Symbol:** FSCI  
**Address:** 0Ch – 0Fh  
**Bits:** 8 each

BIT:	7	6	5	4	3	2	1	0
SYMBOL:	FSCI#	FSCI#	FSCI#	FSCI#	FSCI#	FSCI#	FSCI#	FSCI#
TYPE:	R/W	R/W	R/W	R/W	R/W	R/W	R/W	R/W
DEFAULT:								

Registers FSCI contain a 32-bit value which is used as an increment value for the ROM address generation circuitry when CIVEN=0. The bit locations are specified as follows:

Register	Contents
0Ch	FSCI[31:24]
0Dh	FSCI[23:16]
0Eh	FSCI[15:8]
0Fh	FSCI[7:0]

When the CH7017/CH7018 is used in the clock master mode, the tables below should be used to set the FSCI Registers. When using these values, the CIVEN bit in Register 10h should be set to ‘0’, and the CFRB bit in Register 02h should be set to ‘1’.

**Table 27: FSCI Values (525-Line TV-Out Modes)**

Mode	NTSC “Normal Dot Crawl” (dec)	NTSC “Normal Dot Crawl” (hex)	NTSC “No Dot Crawl” (dec)	NTSC “No Dot Crawl” (hex)	PAL-M “Normal Dot Crawl” (dec)	PAL-M “Normal Dot Crawl” (hex)
2	763,363,328	0x2D800000	763,366,524	0x2D800C7C	762,524,467	0x2D733333
3	623,153,737	0x25249249	623,156,346	0x25249C7A	622,468,953	0x251A1F59
6	574,429,782	0x223D1A56	574,432,187	0x223D23BB	573,798,541	0x2233788D
7	463,962,517	0x1BA78195	463,964,459	0x1BA7892B	463,452,668	0x1B9FB9FC
10	646,233,505	0x2684BDA1	646,236,211	0x2684C833	645,523,358	0x2679E79E
11	521,957,831	0x1F1C71C7	521,960,019	0x1F1C7A53	521,384,251	0x1F13B13B
12	452,363,454	0x1AF684BE	452,365,347	0x1AF68C23	451,866,351	0x1AEFFFFFFF
16	623,153,737	0x25249249	623,156,346	0x25249C7A	622,468,953	0x251A1F59
17	545,259,520	0x20800000	545,261,803	0x208008EB	544,660,334	0x2076DB6E
18	508,908,885	0x1E555555	508,911,016	0x1E555DA8	508,349,645	0x1E4CCCCD
19	553,914,433	0x21041041	553,916,752	0x21041950	553,305,736	0x20FAC688
20	484,675,129	0x1CE38E39	484,677,158	0x1CE39626	484,142,519	0x1CDB6DB7
21	452,363,454	0x1AF684BE	452,365,347	0x1AF68C23	451,866,351	0x1AEFFFFFFF
28	469,762,048	0x1C000000	469,764,015	0x1C0007AF	469,245,826	0x1BF81F82
29	428,554,851	0x198B3A63	428,556,645	0x198B4165	428,083,911	0x19840AC7
30	391,468,373	0x17555555	391,470,012	0x17555BBC	391,038,188	0x174EC4EC
34	526,457,468	0x1F611A7C	526,459,671	0x1F612317	525,878,943	0x1F58469F
35	467,962,193	0x1BE48951	467,964,152	0x1BE490F8	467,447,949	0x1BDCB08D
36	418,281,276	0x18EE773C	418,283,027	0x18EE7E13	417,821,626	0x18E773BA
38	569,408,543	0x21F07C1F	569,410,927	0x21F0856F	568,782,819	0x21E6EFE3
39	574,429,782	0x223D1A56	574,432,187	0x223D23BB	573,798,541	0x2233788D
40	646,233,505	0x2684BDA1	646,236,211	0x2684C833	645,523,358	0x2679E79E
42	555,173,329	0x211745D1	555,175,654	0x21174EE6	554,563,249	0x210DF6B1
43	484,675,129	0x1CE38E39	484,677,158	0x1CE39626	484,142,519	0x1CDB6DB7
44	462,644,441	0x1B9364D9	462,646,378	0x1B936C6A	462,136,041	0x1B8BA2E9



**Table 28: FSCI Values (625-Line TV-Out Modes)**

Mode	PAL “Normal Dot Crawl”	PAL “Normal Dot Crawl”(hex)	PAL-N “Normal Dot Crawl”	PAL-N “Normal Dot Crawl”(hex)
0	806,021,060	0x300AE7C4	651,209,077	0x26D0A975
1	644,816,848	0x266F1FD0	520,967,262	0x1F0D545E
4	601,829,058	0x23DF2EC2	486,236,111	0x1CFB5FCF
5	470,178,951	0x1C065C87	379,871,962	0x16A462DA
8	677,057,690	0x285B149A	547,015,625	0x209ACBC9
9	537,347,373	0x2007452D	434,139,385	0x19E070F9
13	806,021,060	0x300AE7C4	651,209,077	0x26D0A975
14	644,816,848	0x266F1FD0	520,967,262	0x1F0D545E
15	537,347,373	0x2007452D	434,139,385	0x19E070F9
22	690,875,194	0x292DEB3A	558,179,209	0x21452389
23	564,214,742	0x21A13BD6	455,846,354	0x1B2BF022
24	483,612,636	0x1CD357DC	390,725,446	0x1749FF46
25	645,499,916	0x26798C0C	521,519,134	0x1F15C01E
26	528,951,320	0x1F872818	427,355,957	0x1978EF35
27	453,386,846	0x1B06225E	366,305,106	0x15D55F52
31	621,787,675	0x250FBA1B	502,361,288	0x1DF16CCB
32	544,064,215	0x206DC2D7	439,566,127	0x1A333F2F
33	483,612,636	0x1CD357DC	390,725,446	0x1749FF46
37	705,268,427	0x2A098ACB	569,807,942	0x21F69446
41	806,021,060	0x300AE7C4	651,209,077	0x26D0A975
45	686,207,118	0x28E6B08E	554,407,728	0x210B9730
46	577,037,804	0x2264E5EC	466,206,498	0x1BC9BF22
47	494,603,832	0x1D7B0E38	399,605,570	0x17D17F42

**CIV Control Register**

**Symbol:** CIVC  
**Address:** 10h  
**Bits:** 8

BIT:	7	6	5	4	3	2	1	0
SYMBOL:	STFDEN1	STFDEN0	CIV25	CIV24	CIVC1	CIVC0	PALN	CIVEN
TYPE:	R/W	R/W	R	R	R/W	R/W	R/W	R/W
DEFAULT:	0	0	X	X	0	0	0	1

CIVEN (bit 0) of Register CIVC controls whether the FSCI value is used to set the sub-carrier frequency, or the automatically calculated (CIV) value. When the CIVEN value is ‘1’, the number calculated and present at the CIV Registers will automatically be used as the increment value for sub-carrier generation. Whenever this bit is set to ‘1’, the CFRB bit should be set to ‘0’.

PALN (bit 1) of Register CIVC forces the CIV algorithm to generate the PAL-N (Argentina) sub-carrier frequency when it is set to ‘1’. When this bit is set to ‘0’, the VOS[1:0] value is used by the CIV algorithm to determine which sub-carrier frequency to generate.

CIVC[1:0] (bits 3-2) of Register CIVC control the hysteresis circuit which is used to calculate the CIV value. The default value should be used.

CIV[25:24] (bits 5-4) of Register CIVC contain the MSB values for the calculated increment value (CIV) readout. This is the CIV (address 11h-13h) Register description.



STFDEN0 (bit6) of Register CIVC enables the FLD/STL1 output on pin 62.

- STFDEN0 = 0 => FLD/STL1 pin high impedance
- = 1 => Field or stall output depending on the value of the STFDS0 bit in Register 60h, bit 6.

STFDEN1 (bit6) of Register CIVC enables the FLD/STL2 output on pin 105.

- STFDEN1 = 0 => FLD/STL2 pin high impedance
- = 1 => Field or stall output depending on the value of the STFDS1 bit in Register 60h, bit 7.

**Calculated Increment Value Register**

**Symbol:** CIV  
**Address:** 11h –13h  
**Bits:** 8 each

BIT:	7	6	5	4	3	2	1	0
SYMBOL:	CIV#	CIV#	CIV#	CIV#	CIV#	CIV#	CIV#	CIV#
TYPE:	R	R	R	R	R	R	R	R
DEFAULT:	X	X	X	X	X	X	X	X

Registers CIV contain the value that was calculated by the CH7017/CH7018 as the sub-carrier increment value. The entire bit field, CIV[25:0], is comprised of these three Registers CIV[23:0] plus CIV[25:24] contained in the CIV Control Register (10h, bits 4 and 5). This value is used when the CIVEN bit is set to '1'. The bit locations are specified below.

Register	Contents
10h	CIV[25:24]
11h	CIV[23:16]
12h	CIV[15:8]
13h	CIV[7:0]

**Chroma Boost Register**

**Symbol:** CB  
**Address:** 14h  
**Bits:** 1

BIT:	7	6	5	4	3	2	1	0
SYMBOL:	BGBST	Reserved	Reserved	Reserved	Reserved	Reserved	Reserved	Reserved
TYPE:	R/W	R/W	R/W	R/W	R/W	R/W	R/W	R/W
DEFAULT:	0	0	0	0	0	0	0	0

BGBST (bit 7) of register CB boost the bandgap voltage which controls the DAC output by 6% when set to 1. This has the effect of boosting the DAC output by about 6%. The recommended value is 1.



**Clock Mode Register**

**Symbol:** CM  
**Address:** 1Ch  
**Bits:** 7

BIT:	7	6	5	4	3	2	1	0
SYMBOL:	Reserved	IBS2	MCP2	XCM2	M/S*	MCP1	PCM	XCM1
TYPE:	R/W	R/W	R/W	R/W	R/W	R/W	R/W	R/W
DEFAULT:	0	0	0	0	0	0	0	0

XCM1 (bit 0) of Register CM signifies the XCLK frequency for the D1 input. A value of ‘0’ is used when XCLK1 is at the pixel frequency (dual edge clocking mode) and a value of ‘1’ is used when XCLK1 is twice the pixel frequency (single edge clocking mode).

PCM (bit 1) of Register CM controls the P-Out clock frequency. A value of ‘0’ generates a clock output at the pixel frequency, while a value of ‘1’ generates a clock at twice the pixel frequency.

MCP1 (bit 2) of Register CM controls the phase of the XCLK clock input for the D1 input. A value of ‘1’ inverts the XCLK signal at the input of the device. This control is used to select which edge of the XCLK signal to use for latching input data.

M/S\* (bit 3) of Register CM controls whether the device operates in master or slave clock mode. In master mode (M/S\* = ‘1’), the 14.31818MHz clock is used as a frequency reference in the TV PLL, and the M and N values are used to determine the TV PLL’s operating frequency. In slave mode (M/S\* = ‘0’) the XCLK input is used as a reference to the TV PLL. The M and N TV PLL divider values are forced to one.

XCM2 (bit 4) of Register CM signifies the XCLK frequency for the D2 input. A value of ‘0’ is used when XCLK2 is at the pixel frequency (dual edge clocking mode) and a value of ‘1’ is used when XCLK3 is twice the pixel frequency (single edge clocking mode).

MCP2 (bit 5) of Register CM controls the phase of the XCLK clock input for the D2 input. A value of ‘1’ inverts the XCLK signal at the input of the device. This control is used to select which edge of the XCLK signal to use for latching input data.

IBS2 (bit 6) of Register CM selects the data and clock input buffer type for the D2 data according to the following table:

**Table 29: D2 Input Buffer Type Selection**

IBS2	D2 Input Buffer Type
0	CMOS, single ended type for clock and data
1	Differential (clock) and comparator (data) type



**Input Clock Register**

**Symbol: IC**  
**Address: 1Dh**  
**Bits: 5**

BIT:	7	6	5	4	3	2	1	0
SYMBOL:	Reserved	BLKEN	Reserved	Reserved	X1CMD3	X1CMD2	X1CMD1	X1CMD0
TYPE:	R/W	R/W	R/W	R/W	R/W	R/W	R/W	R/W
DEFAULT:	0	1	0	0	1	0	0	0

X1CMD[3:0] (bits 3-0) of Register IC control the delay applied to the XCLK1 signal before latching input data D1[11:0] per the following table. 1 unit is approximately 70 ps worst case.

**Table 30: Delay applied to XCLK1 before latching input data D1**

X1CMD3	X1CMD2	X1CMD1	X1CMD0	Adjust phase of Clock relative to Data
0	0	0	0	0 unit, XCLK1 ahead of Data
0	0	0	1	1 unit, XCLK1 ahead of Data
0	0	1	0	2 unit, XCLK1 ahead of Data
0	0	1	1	3 unit, XCLK1 ahead of Data
0	1	0	0	4 unit, XCLK1 ahead of Data
0	1	0	1	5 unit, XCLK1 ahead of Data
0	1	1	0	6 unit, XCLK1 ahead of Data
0	1	1	1	7 unit, XCLK1 ahead of Data
1	0	0	0	0 unit, XCLK1 behind Data
1	0	0	1	1 unit, XCLK1 behind Data
1	0	1	0	2 unit, XCLK1 behind Data
1	0	1	1	3 unit, XCLK1 behind Data
1	1	0	0	4 unit, XCLK1 behind Data
1	1	0	1	5 unit, XCLK1 behind Data
1	1	1	0	6 unit, XCLK1 behind Data
1	1	1	1	7 unit, XCLK1 behind Data

BLKEN (bit 6) of Register IC controls the Black Level control Register update during the vertical sync blanking period. A value of '0' disables the Black Level control Register update. A value of '1' enables the Black Level control Register update.

**GPIO Control Register**

**Symbol: GPIO**  
**Address: 1Eh**  
**Bits: 8**

BIT:	7	6	5	4	3	2	1	0
SYMBOL:	GOENB1	GOENB0	GPIOL1	GPIOL0	HPIR	HPIE	POUTE	POUTP
TYPE:	R/W	R/W	R/W	R/W	R/W	R/W	R/W	R/W
DEFAULT:	1	1	1	1	0	0	0	0



POUTP (bit 0) of Register GPIO controls the polarity of the P-Out signal. A value of ‘0’ does not invert the clock at the output pad.

POUTE (bit 1) of Register GPIO enables the P-Out signal. A value of ‘1’ drives the P-Out clock signal out of the P-Out pin. A value of ‘0’ disables the P-Out signal.

HPIE (bit 2) of Register GPIO enables the hot plug interrupt detection signal to be output from the HPINT\* pin. A value of ‘1’ allows the hot plug detect circuit to pull the HPINT\* pin low when a change of state has taken place on the hot plug detect pin. A value of ‘0’ disables the interrupt signal.

HPIR (bit 3) of Register GPIO resets the hot plug detection circuitry. A value of ‘1’ causes the CH7017/CH7018 to release the HPINT\* pin. When a hot plug interrupt is asserted by the CH7017/CH7018 (HPINT\*) the CH7017/CH7018 driver should read Register 20h bit 5 to determine the state of the LVDS termination. After having read this bit, the HPIR bit should be set high to reset the circuitry, and then set low again.

GPIOL[1:0] (bits 5-4) of Register GPIO define the GPIO Read or Write Data bits [1:0]. The entire bit field is made up of these bits GPIOL[1:0] plus GPIOL[5:2] contained in the GPIO Data Register (address 6Dh, bits 3-0). Refer to the description of the GPIOD Register (6Dh) for more information.

GOENB[1:0] (bits 7-6) of Register GPIO define the GPIO Direction Control bits [1:0]. The entire bit field is made up of these bits GOENB[1:0] plus GOENB[5:2] contained in the GPIO Direction Control Register (address 6Eh, bits 3-0). Refer to the description of the GPIODC Register (6Eh) for more information.

**Input Data Format Register**

**Symbol: IDF**  
**Address: 1Fh**  
**Bits: 8**

BIT:	7	6	5	4	3	2	1	0
SYMBOL:	IBS1	DES	SYOTV	VSPTV	HSPTV	IDF12	IDF11	IDF10
TYPE:	R/W	R/W	R/W	R/W	R/W	R/W	R/W	R/W
DEFAULT:	0	0	0	0	0	0	0	0

IDF1[2:0] (bits 2-0) of Register IDF select the input data format for the D1 input. The entire bit field, IDF1[3:0], is comprised of this Register IDF1[2:0] plus IDF3 contained in the DAC Control Register (21h, bit5). See **Section 3.2** for a listing of available formats.

HSPTV (bit 3) of Register IDF controls the horizontal sync polarity for TV. A value of ‘0’ defines the horizontal sync to be active low, and a value of ‘1’ defines the horizontal sync to be active high.

VSPTV (bit 4) of Register IDF controls the vertical sync polarity for TV. A value of ‘0’ defines the vertical sync to be active low, and a value of ‘1’ defines the vertical sync to be active high.

SYOTV (bit 5) of Register IDF controls the sync direction for TV. A value of ‘0’ defines sync to be input to the CH7017/CH7018, and a value of ‘1’ defines sync to be output from the CH7017/CH7018. The CH7017/CH7018 can only output sync signals when operating as a VGA to TV encoder, not when operating as an LVDS transmitter.

DES (bit 6) of Register IDF signifies when the CH7017/CH7018 is to decode embedded sync signals present in the input data stream instead of using the H and V pins. This feature is only available for input data formats # 4, 6 or 7. A value of ‘0’ selects the H and V pins to be used as the sync inputs, and a value of ‘1’ selects the embedded sync signal.

IBS1 (bit 7) of Register IDF selects the data and clock input buffer type for the D1 data according to the following table:





**Table 31: D1 Input Buffer Type Selection**

IBS1	D1 Input Buffer Type
0	CMOS, single ended type for clock and data
1	Differential (clock) and comparator (data) type

**Connection Detect Register**

**Symbol:** CD  
**Address:** 20h  
**Bits:** 7

BIT:	7	6	5	4	3	2	1	0
SYMBOL:	Reserved	XOSC2	HPI	DACT3	DACT2	DACT1	DACT0	SENSE
TYPE:	R/W	R/W	R	R	R	R	R	R/W
DEFAULT:	0	1	X	X	X	X	X	0

DACT[3:0] (bits 4-1) and SENSE (bit 0) of Register CD provide a means to sense the connection of a TV to the four DAC outputs. The status bits, DACT[3:0] correspond to the termination of the four DAC outputs. However, the values contained in these status bits ARE NOT VALID until a sensing procedure is performed. Use of this Register requires a sequence of events to enable the sensing of outputs, then reading out the applicable status bits. The detection sequence works as follows:

- 1) Set the power management Register (address 49h) to enable all DAC's.
- 2) Set the SENSE bit to a 1. This forces a constant output from the DAC's. Note that during SENSE = 1, these 4 analog outputs are at steady state and no TV synchronization pulses are asserted.
- 3) Reset the SENSE bit to 0. This triggers a comparison between the voltage present on these analog outputs and the reference value. During this step, each of the four status bits corresponding to individual DAC outputs will be reset to "0" if they are NOT CONNECTED.
- 4) Read the status bits. The status bits, DACT[3:0] now contain valid information which can be read to determine which outputs are connected to a TV. Again, a "1" indicates a valid connection, a "0" indicates an unconnected output.

HPI (bit 5) of Register CD can be read at any time to determine the level of the hot plug detect pin. When the hot plug detect pin changes state, and the LVDS output is selected, the HPINT\* output pin will be pulled low signifying a change in the LVDS termination. At this point, the HPIR bit in Register 1Eh should be set high, then low to reset the hot plug detect circuit.

XOSC2 (bit 6) of Register CD contains the MSB value for the XOSC (crystal oscillator gain control) word which is described in detail in the DC (address 21h) Register description.

**DAC Control Register**

**Symbol:** DC  
**Address:** 21h  
**Bits:** 8

BIT:	7	6	5	4	3	2	1	0
SYMBOL:	XOSC1	XOSC0	IDF13	SYNCO1	SYNCO0	DACG1	DACG0	DACBP
TYPE:	R/W	R/W	R/W	R/W	R/W	R/W	R/W	R/W
DEFAULT:	0	0	0	0	0	0	0	0

DACBP (bit 0) of Register DC selects the DAC bypass mode. A value of '1' outputs the incoming data directly at the DAC[3:0] outputs for the VGA-Bypass RGB output. For the other TV output modes such as S-Video, RCA, SCART and bit must be set to 0.



DACG[1:0] (bits 2-1) of Register DC control the DAC gain. DACG0 should be set to ‘0’ for NTSC and PAL-M video standards, and ‘1’ for PAL and NTSC-J video standards. DACG1 should be ‘0’ when the input data format is RGB (IDF = 0-3, 5, 8 and 9), and ‘1’ when the input data format is YCrCb (IDF = 4, 6 and 7).

SYNCO[1:0] (bits 4-3) of Register DC select the signal to be output from the C/H Sync pin according to **Table 32** below.

**Table 32: Composite / Horizontal Sync Output**

SYNCO[1:0]	Composite / Horizontal Sync Output
00	No Output
01	VGA Horizontal Sync
10	TV Composite Sync
11	TV Horizontal Sync

IDF13 (bit 5) of Register DC is the MSB of the IDF1 word which is described in the IDF (address 1Fh) Register description.

XOSC[1:0] (bits 7-6) of Register DC control the crystal oscillator. The entire bit field, XOSC[2:0], is comprised of XOSC[1:0] from this Register plus XOSC2 contained in the Connection Detect Register (20h, bit 6).The default value is recommended.

**Buffered Clock Output Register**

**Symbol:** BCO  
**Address:** 22h  
**Bits:** 8

BIT:	7	6	5	4	3	2	1	0
SYMBOL:	SHF2	SHF1	SHF0	BCOEN	BCOP	BCO2	BCO1	BCO0
TYPE:	R/W	R/W	R/W	R/W	R/W	R/W	R/W	R/W
DEFAULT:	0	0	0	0	0	0	0	0

BCO[2:0] (bits 2-0) of Register BCO select the signal output at the BCO pin, according to **Table 33** below:

**Table 33: BCO Output Signal**

BCO[2:0]	Buffered Clock Output	BCO[2:0]	Buffered Clock Output
000	The 14MHz crystal	100	Sine ROM MSB
001		101	Cosine ROM MSB
010		110	VGA Vertical Sync
011	Field ID	111	TV Vertical Sync

BCOP (bit 3) of Register BCO selects the polarity of the BCO output. A value of ‘1’ does not invert the signal at the output pad.

BCOEN (bit 4) of Register BCO enables the BCO output pin. When BCOEN is high, the BCO pin will output the selected signal. When BCOEN is low, the BCO pin will be held in tri-state mode.



**Defeat External Vsync Register**

**Symbol: DVS**  
**Address: 47h**  
**Bits: 1**

BIT:	7	6	5	4	3	2	1	0
SYMBOL:	DVS	Reserved	Reserved	Reserved	Reserved	Reserved	Reserved	Reserved
TYPE:	R/W	R/W	R/W	R/W	R/W	R/W	R/W	R/W
DEFAULT:	0	0	0	0	0	0	0	0

DVS (bit 7) of Register DVS defeats the input Vertical SYNC signal going into the VSYNC timing block when set to ‘1’. As a result of this, the internal self generated TV SYNC will be used.

**Test Pattern Register**

**Symbol: STP**  
**Address: 48h**  
**Bits: 5**

BIT:	7	6	5	4	3	2	1	0
SYMBOL:	Reserved	Reserved	TVPLL	ResetIB	ResetDB	Reserved	TSTP1	TSTP0
TYPE:	R/W	R/W	R/W	R/W	R/W	R/W	R/W	R/W
DEFAULT:	0	0	0	1	1	0	0	0

TSTP[1:0] (bits 1:0) of Register STP enable and select test pattern generation (color bar, ramp). This test pattern can be used for both the LVDS output and the TV Output. The pattern generated is determined by the table below:

**Table 34: Test Pattern Selection**

TSTP1	TSTP0	Test Pattern
0	0	No test pattern – Input data is used
0	1	Color Bars
1	0	Horizontal Luminance Ramp
1	1	Horizontal Luminance Ramp

ResetDB (bit 3) of Register STP resets the datapath. When ResetDB is ‘0’ the datapath is reset. When ResetDB is ‘1’ the datapath is enabled. The datapath is also reset at power on by an internally generated power-on-reset signal.

ResetIB (bit 4) of Register STP resets all control Registers (addresses 00h – 7Fh). When ResetIB is ‘0’ the control Registers are reset to the default values. When ResetIB is ‘1’ the control Registers operate normally. The control Registers are also reset at power on by an internally generated power on reset signal.

TVPLL (bit 5) of Register STP resets the TV PLL. When TVPLL is ‘1’ the PLL is reset. When TVPLL is ‘0’ the PLL is enabled. The PLL is also reset at power on by an internally generated power-on-reset signal. In addition it can be reset using the ResetDB bit above.



**Power Management Register**

**Symbol: PM**  
**Address: 49h**  
**Bits: 6**

BIT:	7	6	5	4	3	2	1	0
SYMBOL:	Reserved	Reserved	TV	DACPD3	DACPD2	DACPD1	DACPD0	TVPD
TYPE:	R/W	R/W	R/W	R/W	R/W	R/W	R/W	R/W
DEFAULT:	0	0	0	0	0	0	0	1

TVPD (bit 0) of Register PM controls the TV Out block power down. When TVPD is ‘0’ the TV block is ON. When TVPD is ‘1’ the TV block is powered down.

DACPD[3:0] (bits 4:1) of register PM control DAC0 through DAC3 Power Down. DAC0 through DAC3 will be turned on only if TVPD bit is set to ‘0’. If TVPD bit is set to ‘1’, then DAC0 through DAC3 will be in power down state regardless of DACPD0 through DACPD3 state.

**Table 35: DAC Power Down Control**

TVPD	DACPD[3:0]	Functional Description
0	0000	All DACs on
0	0001	DAC 0 powered down, DACs 1, 2, 3 on
0	0010	DAC 1 powered down, DACs 0, 2, 3 on
0	0100	DAC 2 powered down, DACs 0, 1, 3 on
0	1000	DAC 3 powered down, DACs 0, 1, 2 on
1	xxxx	All DACs powered down

TV (bit 5) of register PM enables the TV path. When TV is ‘0’, the TV data path is disabled. When TV is ‘1’ the TV data path is enabled.

**Version ID Register**

**Symbol: VID**  
**Address: 4Ah**  
**Bits: 8**

BIT:	7	6	5	4	3	2	1	0
SYMBOL:	VID7	VID6	VID5	VID4	VID3	VID2	VID1	VID0
TYPE:	R	R	R	R	R	R	R	R
DEFAULT:	1	0	0	0	0	0	0	1

Register VID is a read only Register containing the version ID number of the CH7017/CH7018 family.

Note:

The Current Version ID of CH7017 is 81h.

The Current Version ID of CH7018 is 01h.



**Device ID Register**

**Symbol: DID**  
**Address: 4Bh**  
**Bits: 8**

BIT:	7	6	5	4	3	2	1	0
SYMBOL:	DID7	DID6	DID5	DID4	DID3	DID2	DID1	DID0
TYPE:	R	R	R	R	R	R	R	R
DEFAULT:	0	0	0	1	1	0	1	1

Register DID is a read only Register containing the device ID number of the CH7017/CH7018 family.

Note:

The Device ID of CH7017 is 1Bh.  
 The Device ID of CH7018 is 1Ah.

**XCLK and D2 Adjust & IDF2**

**Symbol: XDIDF2**  
**Address: 53h**  
**Bits: 8**

BIT:	7	6	5	4	3	2	1	0
SYMBOL:	X2CMD3	X2CMD2	X2CMD1	X2CMD0	IDF23	IDF22	IDF21	IDF20
TYPE:	R/W	R/W	R/W	R/W	R/W	R/W	R/W	R/W
DEFAULT:	1	0	0	0	0	0	0	0

IDF2[3:0] (bits 3-0) of Register XDIDF2 select the input data format for the D2 input. See **Section 3.2** for a listing of available formats.

X2CMD[3:0] (bits 7-4) of Register XDIDF2 control the delay applied to the XCLK2 signal before latching input data D2[11:0] per the following table. 1 unit is approximately 70 ps worst case.

**Table 36: Delay applied to XCLK2 before latching input data D2**

X2CMD3	X2CMD2	X2CMD1	X2CMD0	Adjust phase of Clock relative to Data
0	0	0	0	0 unit, XCLK2 ahead of Data
0	0	0	1	1 unit, XCLK2 ahead of Data
0	0	1	0	2 unit, XCLK2 ahead of Data
0	0	1	1	3 unit, XCLK2 ahead of Data
0	1	0	0	4 unit, XCLK2 ahead of Data
0	1	0	1	5 unit, XCLK2 ahead of Data
0	1	1	0	6 unit, XCLK2 ahead of Data
0	1	1	1	7 unit, XCLK2 ahead of Data
1	0	0	0	0 unit, XCLK2 behind Data
1	0	0	1	1 unit, XCLK2 behind Data
1	0	1	0	2 unit, XCLK2 behind Data
1	0	1	1	3 unit, XCLK2 behind Data
1	1	0	0	4 unit, XCLK2 behind Data
1	1	0	1	5 unit, XCLK2 behind Data
1	1	1	0	6 unit, XCLK2 behind Data
1	1	1	1	7 unit, XCLK2 behind Data



**Up Scaler Coefficient Register 0**

**Symbol:** USCR0  
**Address:** 55h  
**Bits:** 8 each

BIT:	7	6	5	4	3	2	1	0
SYMBOL:	USC12	USC11	USC10	USC04	USC03	USC02	USC01	USC00
TYPE:	R/W	R/W	R/W	R/W	R/W	R/W	R/W	R/W
DEFAULT:	0	0	0	0	0	0	0	0

This Register contains the LSB byte of the Up Scaler Coefficient defined by USCR[4:0] in Registers 55h to 59h. There are eight Up Scaler coefficients (USC7:0) in groups of 5 bits. Register USCR0 contains the entire coefficient USC0[4:0] and 3 bits from coefficient USC1.

The value of each coefficient should be in 2’s complement format.

**Default Up Scaler Coefficient :**

USC	8 [39:35]	7[34:30]	6[29:25]	5[24:20]	4[19:15]	3[14:10]	2[9:5]	1[4:0]
Default	8	8	7	4	1	0	0	0

Note: USC0[4:0] must be always zero and the other coefficient values must be between –3 to 11 in 2’s complement number. The default Up Scaler Coefficient value is for a non-linear interpolation up scaling function.

**Up Scaler Coefficient Register 1**

**Symbol:** USCR1  
**Address:** 56h  
**Bits:** 8

BIT:	7	6	5	4	3	2	1	0
SYMBOL:	USC30	USC24	USC23	USC22	USC21	USC20	USC14	USC13
TYPE:	R/W	R/W	R/W	R/W	R/W	R/W	R/W	R/W
DEFAULT:	1	0	0	0	0	0	0	0

This Register contains the second byte of the Up Scaler Coefficient defined by USCR[4:0] in Registers 55h to 59h. There are eight Up Scaler coefficients ( USC7:0) in groups of 5 bits. Register USCR1 contains the entire coefficient USC2[4:0], 2 bits from coefficient USC1 and 1 bit from coefficient USC3.

The value of each coefficient should be in 2’s complement format.

The default values of the Up Scaler coefficients are described in the USCR0 Register (address 55h) description.



**Up Scaler Coefficient Register 2**

**Symbol: USCR2**  
**Address: 57h**  
**Bits: 8**

BIT:	7	6	5	4	3	2	1	0
SYMBOL:	USC43	USC42	USC41	USC40	USC34	USC33	USC32	USC31
TYPE:	R/W	R/W	R/W	R/W	R/W	R/W	R/W	R/W
DEFAULT:	0	1	0	0	0	0	0	0

This Register contains the third byte of the Up Scaler Coefficient defined by USCR[4:0] in Registers 55h to 59h. There are eight Up Scaler coefficients ( USC7:0) in groups of 5 bits. Register USCR2 contains 4 bits from coefficient USC3 and 4 bits from coefficient USC4. The value of each coefficient should be in 2’s complement format.

The default values of the Up Scaler coefficients are described in the USCR0 Register (address 55h) description.

**Up Scaler Coefficient Register 3**

**Symbol: USCR3**  
**Address: 58h**  
**Bits: 8**

BIT:	7	6	5	4	3	2	1	0
SYMBOL:	USC61	USC60	USC54	USC53	USC52	USC51	USC50	USC44
TYPE:	R/W	R/W	R/W	R/W	R/W	R/W	R/W	R/W
DEFAULT:	0	0	0	0	1	1	1	0

This Register contains the fourth byte of the Up Scaler Coefficient defined by USCR[4:0] in Registers 55h to 59h. There are eight Up Scaler coefficients ( USC7:0) in groups of 5 bits. Register USCR3 contains the entire coefficient USC5[4:0], 1 bit from coefficient USC4 and 2 bits from coefficient USC6.

The value of each coefficient should be in 2’s complement format.

The default values of the Up Scaler coefficients are described in the USCR0 Register (address 55h) description.

**Up Scaler Coefficient Register 4**

**Symbol: USCR4**  
**Address: 59h**  
**Bits: 8**

BIT:	7	6	5	4	3	2	1	0
SYMBOL:	USC74	USC73	USC72	USC71	USC70	USC64	USC63	USC62
TYPE:	R/W	R/W	R/W	R/W	R/W	R/W	R/W	R/W
DEFAULT:	0	1	0	0	0	0	1	0

This Register contains the fifth byte of the Up Scaler Coefficient defined by USCR[4:0] in Registers 55h to 59h. There are eight Up Scaler coefficients ( USC7:0) in groups of 5 bits. Register USCR4 contains the entire coefficient USC7[4:0] and 3 bits from coefficient USC6.

The value of each coefficient should be in 2’s complement format.

The default values of the Up Scaler coefficients are described in the USCR0 Register (address 55h) description.



**Up Scaler Vertical Increment Value 0**

**Symbol:** USVIV0  
**Address:** 5Ah  
**Bits:** 8

BIT:	7	6	5	4	3	2	1	0
SYMBOL:	USVIV7	USVIV6	USVIV5	USVIV4	USVIV3	USVIV2	USVIV1	USVIV0
TYPE:	R/W	R/W	R/W	R/W	R/W	R/W	R/W	R/W
DEFAULT:	0	1	1	1	1	1	1	1

Register USVIV0 defines the Up Scaler Vertical Increment Value bits [7:0]. The entire bit field, USVIV[17:0], is comprised of this Register USVIV[7:0] plus USVIV[15:8] contained in the Upscaler vertical Increment Value 1 Register (5Bh) and USVIV[17:16] in the Upscaler Increment Value Register (5Ch).

For computing the value of USVIV[17:0] use following equation below:

$$USVIV = 2^{18} \times \frac{VALI - 1}{VALO - 1}$$

where ( for example, input is 640 x 480 and LVDS panel output is 1024 x 768 )

VALI is the Vertical Active Line Input from a VGA controller (480 in this example).

VALO is the Vertical Active Line Output and is equal to the LVDS vertical resolution (768 in this example).

Refer to Register 60-61h.

USVIV is the Up Scaler Vertical Increment Value which is in an integer number with truncated (do not round off) decimal (163711 in this example).

**Up Scaler Vertical Increment Value 1**

**Symbol:** USVIV1  
**Address:** 5Bh  
**Bits:** 8

BIT:	7	6	5	4	3	2	1	0
SYMBOL:	USVIV15	USVIV14	USVIV13	USVIV12	USVIV11	USVIV10	USVIV9	USVIV8
TYPE:	R/W	R/W	R/W	R/W	R/W	R/W	R/W	R/W
DEFAULT:	0	1	1	1	1	1	1	1

Register USVIV1 defines the Up Scaler Vertical Increment Value bits [15:8]. The entire bit field, USVIV[17:0], is comprised of this Register USVIV[15:8] plus USVIV[7:0] contained in the Upscaler Vertical Increment Value 0 Register (5Ah) and USVIV[17:16] in the Upscaler Increment Value Register (5Ch).

For computing the value of USVIV[17:0] refer to the description for Register USVIV0 (address 5Ah).





**GPIO Invert**

**Symbol:** GPIOINV  
**Address:** 5Ch  
**Bits:** 7

BIT:	7	6	5	4	3	2	1	0
SYMBOL:	C5GP2	C5GP1	C5GP0	Reserved	USHIV17	USHIV16	USVIV17	USVIV16
TYPE:	R/W	R/W	R/W	R/W	R/W	R/W	R/W	R/W
DEFAULT:	0	0	0	0	1	0	1	0

USVIV[17:16] (bits 1:0) of Register USIV define the Up Scaler Vertical Increment Value bits [17:16]. The entire bit field, USVIV[17:0], is comprised of these bits USVIV[17:16] plus USVIV[7:0] contained in the Upscaler Vertical Increment Value 0 Register (5Ah) and USVIV[15:8] in the Upscaler Vertical Increment Value 1 Register (5Bh).

For computing the value of USVIV[17:0] refer to the description for Register USVIV0 (address 5Ah).

C5GP[2:0] (bits 7-5) of Register GPIOINV define the GPIO C5 Control bits [5:4]. The entire bit field is made up of these bits C5GP[2:0] plus C5GP[5:3] contained in the LVDS Encoding 2 Register (65h, bits 7-5). Refer to the description of the LVDSE2 Register (address 65h) for more information.

**Up Scaler Horizontal Increment Value 0**

**Symbol:** USHIV0  
**Address:** 5Dh  
**Bits:** 8

BIT:	7	6	5	4	3	2	1	0
SYMBOL:	USHIV7	USHIV6	USHIV5	USHIV4	USHIV3	USHIV2	USHIV1	USHIV0
TYPE:	R/W	R/W	R/W	R/W	R/W	R/W	R/W	R/W
DEFAULT:	1	0	0	1	1	1	1	1

Register USHIV0 defines the Up Scaler Horizontal Increment Value bits [7:0]. The entire bit field, USHIV[17:0], is comprised of these bits USHIV[7:0] plus USHIV[15:8] contained in the Up Scaler Horizontal Increment Value 1 Register (5Eh) and USHIV[17:16] in the Up Scaler Increment Value Register (5Ch).

For computing the value of USHIV[17:0] use following equation below:

$$USHIV = 2^{18} \times \frac{HAPI - 1}{HAPO}$$

where (for example, input is 640 x 480 and LVDS panel output is 1024 x 768 )

HAPI is the Horizontal Active Pixel Input from VGA controller (640 in this example).

HAPO is the Horizontal Active Pixel Output and is equal to LVDS panel horizontal resolution minus one (1024-1 = 1023 in this example). Refer to Registers 62h-63h.

USHIV is the Up Scaler Horizontal Increment Value which is an integer number with truncated (do not round off) decimal (163743 in this example)



**Up Scaler Horizontal Increment Value 1**

**Symbol:** USHIV1  
**Address:** 5Eh  
**Bits:** 8

BIT:	7	6	5	4	3	2	1	0
SYMBOL:	USHIV15	USHIV14	USHIV13	USHIV12	USHIV11	USHIV10	USHIV9	USHIV8
TYPE:	R/W	R/W	R/W	R/W	R/W	R/W	R/W	R/W
DEFAULT:	0	1	1	1	1	1	1	1

Register USHIV1 defines the Up Scaler Horizontal Increment Value bits [15:8]. The entire bit field, USHIV[17:0], is comprised of these bits USHIV[15:8] plus USHIV[7:0] contained in the Upscaler Horizontal Increment Value 0 Register (5Dh) and USHIV[17:16] in the Upscaler Increment Value Register (5Ch).

For computing the value of USHIV[17:0] refer to the description for Register USHIV0 (address 5Dh).

**Horizontal Active Pixel Input**

**Symbol:** HAPI  
**Address:** 5Fh  
**Bits:** 8

BIT:	7	6	5	4	3	2	1	0
SYMBOL:	HAPI7	HAPI6	HAPI5	HAPI4	HAPI3	HAPI2	HAPI1	HAPI0
TYPE:	R/W	R/W	R/W	R/W	R/W	R/W	R/W	R/W
DEFAULT:	1	0	0	0	0	0	0	0

Register HAPI defines the Horizontal Active Pixel Input value (from a VGA controller) bits [7:0]. The entire bit field, HAPI[10:0], is comprised of these bits HAPI[7:0] plus HAPI[10:8] contained in the Active Pixel Input and Line Output Register (60h). For example, if the VGA input resolution is 640 x 480, the value of HAPI[10:0]=280h=640.

**Active Pixel Input & Line Output**

**Symbol:** APILO  
**Address:** 60h  
**Bits:** 8

BIT:	7	6	5	4	3	2	1	0
SYMBOL:	STFDS1	STFDS0	VALO10	VALO9	VALO8	HAPI10	HAPI9	HAPI8
TYPE:	R/W	R/W	R/W	R/W	R/W	R/W	R/W	R/W
DEFAULT:	1	0	0	1	1	0	1	0

HAPI[10:8] (bits 2-0) of Register APILO define the Horizontal Active Pixel Input value bits [10:8]. The entire bit field, HAPI[10:0], is comprised of these bits HAPI[10:8] plus HAPI[7:0] contained in the Horizontal Active Pixel Input Register (address 5Fh). Refer to the description of the HAPI Register (address 5Fh) for more details.



VALO[10:8] (bits 5-3) of Register APILO define the Vertical Active Line Output value bits [10:8]. The entire bit field, VALO[10:0], is comprised of these bits VALO[10:8] plus VALO[7:0] contained in the Vertical Active Line Output Register (address 61h). Refer to the description of the VALO Register (address 61h) for more details.

STFDS[1:0] (bits 8-7) of Register APILO control FLD/STL2 and FLD/STL1 output to a VGA controller. These bits can be programmed to be either a TV field output from the TV encoder or a Stall output from the flat panel Up-Scaler. These outputs are tri-stated upon power up. A value of '1' allows FLD output. A value of '0' enables STL output. STFDS0 controls FLD/STL1 and STFDS1 controls FLD/STL2 output. Note that the FLD/STLx pins must first be enabled using the STFDENx bits located in Register 10h, bits 7-6.

**Vertical Active Line Output**

**Symbol: VALO**  
**Address: 61h**  
**Bits: 8**

BIT:	7	6	5	4	3	2	1	0
SYMBOL:	VALO7	VALO6	VALO5	VALO4	VALO3	VALO2	VALO1	VALO0
TYPE:	R/W	R/W	R/W	R/W	R/W	R/W	R/W	R/W
DEFAULT:	0	0	0	0	0	0	0	0

Register VALO defines the Vertical Active Line Output value bits [7:0]. The entire bit field, VALO[10:0], is comprised of these bits VALO[7:0] plus VALO[10:8] contained in the Active Pixel Input and Line Output Register (60h). VALO[10:0] is equal to the target LVDS panel vertical resolution. For example, if the LVDS panel resolution is 1024 x 768, the value of VALO[10:0]=300h=768).

**Horizontal Active Pixel Output**

**Symbol: HAPO**  
**Address: 62h**  
**Bits: 8**

BIT:	7	6	5	4	3	2	1	0
SYMBOL:	HAPO7	HAPO6	HAPO5	HAPO4	HAPO3	HAPO2	HAPO1	HAPO0
TYPE:	R/W	R/W	R/W	R/W	R/W	R/W	R/W	R/W
DEFAULT:	1	1	1	1	1	1	1	1

Register HAPO defines the Horizontal Active Pixel Output value bits [7:0]. The entire bit field, HAPO[10:0], is comprised of these bits HAPO[7:0] plus HAPO[10:8] contained in the LVDS Test Mode and Horizontal Active Pixel Output Register (address 63h, bits 2-0). The value of HAPO[10:0] is equal to the target LVDS panel horizontal resolution minus one. For example, if the target LVDS Panel resolution is 1024 x 768, the value of HAPO[10:0]=3FFh=(1024-1).



**LVDS Power Down**

**Symbol: LPD**  
**Address: 63h**  
**Bits: 5**

BIT:	7	6	5	4	3	2	1	0
SYMBOL:	US	LVDSPD	Reserved	Reserved	Reserved	HAPO10	HAPO9	HAPO8
TYPE:	R/W	R/W	R/W	R/W	R/W	R/W	R/W	R/W
DEFAULT:	0	0	0	0	1	0	1	1

HAPO[10:8] (bits 2-0) of Register LPD define the Horizontal Active Pixel Output value bits [10:8]. The entire bit field, HAPO[10:0], is comprised of these bits HAPO[10:8] plus HAPO[7:0] contained in the Horizontal Active Pixel Output Register (62h). Refer to the description of the HAPO Register (address 62h) for more information.

LVDSPD (bit 6) of Register LPD controls the LVDS power down. When LVDSPD is '0' the LVDS path is ON, when LVDSPD is '1' the LVDS path is powered down.

US (bit 7) of Register LPD enables the up scaler function. When US is '0' the up scaler is disabled, when US is '1' the up scaler is enabled.

**LVDS Encoding 1 Register**

**Symbol: LVDSE1**  
**Address: 64h**  
**Bits: 7**

BIT:	7	6	5	4	3	2	1	0
SYMBOL:	HVEN	Reserved	LVDS24	LVDSDC	LDD	LDM2D	LEOSWP	LDI
TYPE:	R/W	R/W	R/W	R/W	R/W	R/W	R/W	R/W
DEFAULT:	0	0	0	0	1	1	0	1

LDI (bit 0) of Register LVDSE1 controls OpenLDI specification selection. A '1' corresponds to OpenLDI, and a '0' corresponds to SPWG. See **Section 3.4.1** for more details.

LEOSWP (bit 1) of Register LVDSE1 provides the added flexibility to swap odd/even samples output on the LVDS link.

LDM2D (bit 2) of Register LVDSE1 selects the dithering function to minimize quantization noise by spreading it out spatially. A '1' turns on the 2D dither function, and a '0' turns off the dither function.

LDD (bit 3) of Register LVDSE1 bypasses the dither function. A '1' bypasses the dither function. A '0' does not bypass the dither function.

LVDSDC (bit 4) of Register LVDSE1 allows single or dual channel LVDS to be selected. If the bit is 1, dual channel is selected. If the bit is 0, single channel is selected.

LVDS24 (bit 5) of Register LVDSE1 selects LVDS 24 bit or 18 bit output format. A '1' provides 24-bit output mode and a '0' provides 18-bit output mode.

HVEN (bit 7) of Register LVDSE1 controls HOUT and VOUT output level translators from HIN and VIN respectively. When HVEN is '0' the level translators are disabled and HOUT and VOUT are in tri-state. When HVEN is '1' the level



**LVDS Encoding 2 Register**

**Symbol:** LVDSE2  
**Address:** 65h  
**Bits:** 8

BIT:	7	6	5	4	3	2	1	0
SYMBOL:	C5GP5	C5GP4	C5GP3	LA3RL	LA6RL	LA7RL	LCNTLE	LCNTLF
TYPE:	R/W	R/W	R/W	R/W	R/W	R/W	R/W	R/W
DEFAULT:	0	0	0	0	0	0	0	0

LCNTLF and LCNTLE (bits 1-0) of Register LVDSE2 are OpenLDI miscellaneous control signals, Cntl F and Cntl E, for the Display Source Serializer respectively. Refer to the OpenLDI specification v0.95. See **Section 3.4.2**.

LA7RL and LA3RL (bits 4 and 2) of Register LVDSE2 are OpenLDI reserved bits for future use and may take any value in 24 bit unbalanced dual pixel mode. Refer to the OpenLDI specification v0.95. See **Section 3.4.2**.

LA6RL (bit 3) of Register LVDSE2 is an OpenLDI reserved bit for future use and may take any value. Refer to the OpenLDI specification v0.95, P5. See **Section 3.4.2**.

C5GP[5:3] (bits 7-5) of Register LVDSE2 define the GPIO C5 Control bits [5:3]. The entire bit field is made up of these bits C5GP[5:3] plus C5GP[2:0] contained in the GPIO Invert Register (5Ch, bits 7-5). C5GP[5:0] invert the data output on the GPIO[5:0] pins when the pins are configured in output mode. When the corresponding GOENB bits (GOENB[5:0], see GPIODC Register, address 6Eh, bits 3-0 and GPIO Register, address 1Eh, bits 7-6) are '0' and the corresponding C5GP bits are '1' the values in GPIOL[5:0] are driven out inverted at the corresponding GPIO pins.

**LVDS PLL Miscellaneous Control Register**

**Symbol:** LPMC  
**Address:** 66h  
**Bits:** 7

BIT:	7	6	3	4	3	2	1	0
SYMBOL:	Reserved	SYNCST	BKLEN	LPLEN	LPFORC	LPLOCK	LSYNCEN	PANEN
TYPE:	R/W	R	R/W	R/W	R/W	R	R/W	R/W
DEFAULT:	0	0	0	0	0	0	0	1

The LPMC Register controls panel protection circuits which control the LVDS panel power up and down sequence (refer to **Section 3.4.6** Panel Protection).

PANEN (bit 0) of the LPMC Register controls the LVDS panel enable.

- PANEN = 0 => Begin Power off sequence
- PANEN = 1 => Power-on

LSYNCEN (bit 1) of the LPMC Register controls the Sync Detection Enable for Power Down.

- LSYNCEN = 0 => Normal Power down based on abnormal HSYNC and VSYNC detection.
- LSYNCEN = 1 => Force unstable SYNC state regardless of HSYNC and VSYNC status to initiate Power Down cycle via SW control.

LPLOCK (bit 2) of the LPMC Register indicates the status of the PLL Lock

- LPLOCK = 0 => PLL is not stable.
- LPLOCK = 1 => PLL is stable and properly locked.

LPFORC (bit 3) of the LPMC register : Bypass LVDS Lock Detect Sentry

- Bit 3 = 0 => Lock detect sentry is active.
- Bit 3 = 1 => Lock detect sentry is overridden if LPLEN is set to '1'.



LPLEN (bit 4) of the LMPC register controls LVDS PLL Lock Enable between LPLOCK and LPFORC.

- LPLEN = 0 => Select LPLOCK (normal operation)
- = 1 => Select LPFORC (Lock detect sentry is overridden if LPFORC is set to '1')

BKLEN (bit 5) of the LMPC Register enables the panel backlight.

- BKLEN = 0 => Disable Backlight
- =1 => Enable Backlight

SYNCST(bit 6) of the LMPC Register is the Hsync and Vsync stability status bit. Refer to **Section 3.4.6**.

- SYNCST = 0 => Hsync or Vsync are not stable
- = 1 => Hsync and Vsync are stable

**Power Sequencing T1**

**Symbol: PST1**  
**Address: 67h**  
**Bits: 8**

BIT:	7	6	5	4	3	2	1	0
SYMBOL:	TPON7	TPON6	TPON5	TPON4	TPON3	TPON2	TPON1	TPON0
TYPE:	R/W	R/W	R/W	R/W	R/W	R/W	R/W	R/W
DEFAULT:	0	0	0	0	0	0	0	0

This Register defines Power On time (T1), the time duration between LVDS\_RDY (internal signal) to valid LVDS Clock and Data. The entire bit field, TPON[8:0], is comprised of these bits TPON[7:0] plus TPON8 contained in the PST2 Power Sequencing T2 Register (68h). Refer to **Figure 19** and **Table 16** in **Section 3.4.5**. The range of T1 is 1ms to 512ms in increments of 1ms.

**Power Sequencing T2**

**Symbol: PST2**  
**Address: 68h**  
**Bits: 8**

BIT:	7	6	5	4	3	2	1	0
SYMBOL:	TPON8	TPBLE6	TPBLE5	TPBLE4	TPBLE3	TPBLE2	TPBLE1	TPBLE0
TYPE:	R/W	R/W	R/W	R/W	R/W	R/W	R/W	R/W
DEFAULT:	0	0	0	0	0	0	0	0

TPBLE[6:0] (bits 6:0) of Register PST2 define the Back Light Enable time (T2), the waiting time after valid LVDS Clock and Data before enabling the LVDS panel back light. Refer to **Figure 19** and **Table 16** in **Section 3.4.5**. The range of T2 is 2ms to 256ms in increments of 2ms.

TPON8 (bit 7) of Register PST2 defines the MSB of the Power On time (T1). The entire bit field, TPON[8:0], is comprised of this bit, TPON8, plus TPON[7:0] contained in the Power Sequencing T1 Register (address 67h). Refer to the description of the PST1 Register (address 67h) for more information.



**Power Sequencing T3**

**Symbol: PST3**  
**Address: 69h**  
**Bits: 8**

BIT:	7	6	5	4	3	2	1	0
SYMBOL:	TPOFF8	TPBLD6	TPBLD5	TPBLD4	TPBLD3	TPBLD2	TPBLD1	TPBLD0
TYPE:	R/W	R/W	R/W	R/W	R/W	R/W	R/W	R/W
DEFAULT:	0	0	0	0	0	0	0	0

TPBLD[6:0] (bits 6-0) of Register PST3 define the Back Light Disable time (T3), the required time after disabling the back light before the valid LVDS Clock and Data become tri-stated or disabled. Refer **Figure 19** and **Table 16** in **Section 3.4.5**. The range of T3 is 2ms to 256ms in increments of 2ms.

TPOFF8 (bit 7) of Register PST3 defines the MSB of the Power Off time (T4). The entire bit field, TPOFF[8:0], is comprised of this bit, TPOFF8, plus TPOFF[7:0] contained in the Power Sequencing T4 Register (address 6Ah). Refer to the description of the PST4 Register (address 6Ah) for more information.

**Power Sequencing T4**

**Symbol: PST4**  
**Address: 6Ah**  
**Bits: 8**

BIT:	7	6	5	4	3	2	1	0
SYMBOL:	TPOFF7	TPOFF6	TPOFF5	TPOFF4	TPOFF3	TPOFF2	TPOFF1	TPOFF0
TYPE:	R/W	R/W	R/W	R/W	R/W	R/W	R/W	R/W
DEFAULT:	0	0	0	0	0	0	0	0

Register PST4 defines the Power Off time (T4), the required time prior to power off after the valid LVDS Clock and Data become tri-stated or disabled. The entire bit field, TPOFF[8:0], is comprised of these bits, TPOFF[7:0], plus TPOFF8 contained in the Power Sequencing T3 Register (address 69h). Refer to **Figure 19** and **Table 16** in **Section 3.4.5**.

The range is 1ms to 512ms in increments of 1ms.

**Power Sequencing T5**

**Symbol: PST5**  
**Address: 6Bh**  
**Bits: 8**

BIT:	7	6	5	4	3	2	1	0
SYMBOL:	C4GP5	C4GP4	TPPWD5	TPPWD4	TPPWD3	TPPWD2	TPPWD1	TPPWD0
TYPE:	R/W	R/W	R/W	R/W	R/W	R/W	R/W	R/W
DEFAULT:	1	1	0	0	0	0	0	1

TPPWD[5:0] (bits 5-0) of Register PST5 define the Power Cycle time (T5), the waiting time required prior to enabling power on after power has been off. Refer to **Figure 19** and **Table 16** in **Section 3.4.5**. The range is 0 to 1600ms in increments of 50ms.



C4GP[5:4] (bits 7-6) of Register PST5 define the GPIO C4 Control bits [5:4]. The entire bit field is made up of these bits C4GP[5:4] plus C4GP[3:2] contained in the GPIO Driver Type Register (6Ch, bits 7-6) and C4GP[1:0] contained in the GPIO Data [5:2] Register (6Dh, bits 7-6). Refer to the description of the GPIOD Register (6Dh) for more information.

**GPIO Driver Type**

**Symbol: GPIODR**  
**Address: 6Ch**  
**Bits: 8**

BIT:	7	6	5	4	3	2	1	0
SYMBOL:	C4GP3	C4GP2	GPIODR5	GPIODR4	GPIODR3	GPIODR2	GPIODR1	GPIODR0
TYPE:	R/W	R/W	R/W	R/W	R/W	R/W	R/W	R/W
DEFAULT:	1	1	1	1	1	1	1	1

GPIODR[5:0] (bits 5:0) of Register GPIODR defines the output driver type for pins GPIO[5:0] – CMOS or Open Drain. A value of ‘0’ sets corresponding GPIO output to CMOS output type , and a value of ‘1’ sets corresponding GPIO output to Open Drain type.

C4GP[3:2] (bits 7-6) of Register GPIODR define the GPIO C4 Control bits [3:2]. The entire bit field is made up of these bits C4GP[3:2] plus C4GP[5:4] contained in the Power Sequencing T5 Register (6Bh, bits 7-6) and C4GP[1:0] contained in the GPIO Data [5:2] Register (6Dh, bits 7-6). Refer to the description of the GPIOD Register (6Dh) for more information.

**GPIO Data**

**Symbol: GPIOD**  
**Address: 6Dh**  
**Bits: 8**

BIT:	7	6	5	4	3	2	1	0
SYMBOL:	C4GP1	C4GP0	C3GP5	C3GP4	GPIOL5	GPIOL4	GPIOL3	GPIOL2
TYPE:	R/W	R/W	R/W	R/W	R/W	R/W	R/W	R/W
DEFAULT:	1	1	0	0	1	1	1	1

GPIOL[5:2] (bits 3-0) of Register GPIOD define the GPIO Read or Write Data bits [5:2]. The entire bit field is made up of these bits GPIOL[5:2] plus GPIOL[1:0] contained in the GPIO Control Register (1Eh, bits 5-4). GPIOL[5:0] define the state of the GPIO[5:0] pins in read or write mode.

When the corresponding GOENB bits (GOENB[5:0], see GPIO Control Register, address 1Eh, bits 7-6 and GPIO Direction Control Register, address 6Eh, bits 3-0) are ‘0’, the values in GPIOL[5:0] are driven out at the corresponding GPIO pins. When the corresponding GOENB bits are ‘1’, the values in GPIOL[5:0] can be read to determine the level forced into the corresponding GPIO pins. Note that the default state of GPIOLx depends on the state of the GPIOx pins since by default these pins are configured as inputs. With no external pullup or pulldown the internal pullup created by C4GPx being ‘1’ causes GPIOLx to be ‘1’.

When the corresponding GOENB bits are ‘0’ and the corresponding C5GP bits (C5GP[5:0], see GPIOINV Register, address 5Ch, bits 7-5 and LVDSE2 Register, address 65h, bits 7-5) are ‘1’ the values in GPIOL[5:0] are driven out inverted at the corresponding GPIO pins.

C3GP[5:4] (bits 5-4) of Register GPIOD define the GPIO C3 Control bits [5:4]. The entire bit field is made up of these bits C3GP[5:4] plus C3GP[3:0] contained in the GPIO Direction Control Register (6Eh, bits 7-4). C3GP[5:0] control the weak pull-down (approximately 1MΩ) for the pins GPIO[5:0]. A value of ‘0’ means no pull-down, a value of ‘1’ means the pull-down is active.





C4GP[1:0] (bits 7-6) of Register GPIOD define the GPIO C4 Control bits [1:0]. The entire bit field is made up of these bits C4GP[1:0] plus C4GP[5:4] contained in the Power Sequencing T5 Register (6Bh, bits 7-6) and C4GP[3:2] contained in the GPIO Driver Type Register (6Ch, bits 7-6). C4GP[5:0] control the weak pull-up (approximately 1MΩ) for the pins GPIO[5:0]. A value of ‘0’ means no pull-up, a value of ‘1’ means the pull-up is active.

**GPIO Direction Control**

**Symbol: GPIODC**  
**Address: 6Eh**  
**Bits: 8**

BIT:	7	6	5	4	3	2	1	0
SYMBOL:	C3GP3	C3GP2	C3GP1	C3GP0	GOENB5	GOENB4	GOENB3	GOENB2
TYPE:	R/W	R/W	R/W	R/W	R/W	R/W	R/W	R/W
DEFAULT:	0	0	0	0	1	1	1	1

GOENB[5:2] (bits 3-0) of Register GPIODC define the GPIO Direction Control bits [5:2]. The entire bit field is made up of these bits GOENB[5:2] plus GOENB[1:0] contained in the GPIO Control Register (address 1Eh, bits 7-6). GOENB[5:0] control the direction of the GPIO[5:0] pins. A value of ‘1’ sets the corresponding GPIO pin to an input, and a value of ‘0’ sets the corresponding pin to a non-inverting output. The level at the output depends on the value of the corresponding bit GPIOL[5:0]. Refer to the description for the GPIOD Register (address 6Dh) for more information.

C3GP[3:0] (bits 7-4) of Register GPIODC define the GPIO C3 Control bits [3:0]. The entire bit field is made up of these bits C3GP[3:0] plus C3GP[5:4] contained in the GPIO Data [5:2] Register (6Dh, bits 5-4). Refer to the description of the GPIOD Register (address 6Dh) for more information.

**LVDS PLL Feed Back Divider Control**

**Symbol: LPFBDC**  
**Address: 71h**  
**Bits: 6**

BIT:	7	6	5	4	3	2	1	0
SYMBOL:	Reserved	Reserved	LPFFD1	LPFFD0	LPFBD3	LPFBD2	LPFBD1	LPFBD0
TYPE:	R/W	R/W	R/W	R/W	R/W	R/W	R/W	R/W
DEFAULT:	1	0	1	0	0	0	1	1

LPFBD[3:0] (bits 3-0) of Register LPFBDC define the LVDS PLL Feed-Back Divider Control. The recommended settings are shown in **Table 41** in **Section 4.3**.

LPFFD[1:0] (bits 5:4) of Register LPFBDC define the LVDS PLL Feed-Forward Divider Control. The recommended settings are shown in **Table 41** in **Section 4.3**.



**LVDS PLL VCO Control Register**

**Symbol:** LPVC  
**Address:** 72h  
**Bits:** 6

BIT:	7	6	5	4	3	2	1	0
SYMBOL:	Reserved	Reserved	LPPSD1	LPPSD0	LPVCO3	LPVCO2	LPVCO1	LPVCO0
TYPE:	R/W	R/W	R/W	R/W	R/W	R/W	R/W	R/W
DEFAULT:	1	0	0	1	0	1	1	0

LPVCO[3:0] (bits 3-0) of Register LPVC determine the LVDS PLL VCO open-loop frequency range. The recommended settings are shown in **Table 41** in **Section 4.3**.

LPPSD[1:0] (bits 5:4) of Register LPVC define the LVDS PLL post scale divider controls. The recommended settings are shown in **Table 41** in **Section 4.3**.

**Outputs Enable Register**

**Symbol:** OUTEN  
**Address:** 73h  
**Bits:** 8

BIT:	7	6	5	4	3	2	1	0
SYMBOL:	LSP2	DAS1	DAS0	LDEN1	LDENO	LPCP2	LPCP1	LPCP0
TYPE:	R/W	R/W	R/W	R/W	R/W	R/W	R/W	R/W
DEFAULT:	1	1	0	0	1	0	0	0

LPCP[2:0] (bits 2-0) of Register LPCPC control the LVDS PLL Charge Pump current value. The recommended settings are shown in **Table 41**.

LDEN[1:0] (bits 4-3) of Register LPCPC control the output drivers of LVDS output Channel A (LDC[2:0], LDC\*[2:0], LL1C and LL1C\*), and Channel B ( LDC[6:4], LDC\*[6:4], LL2C and LL2C\*) per the following table:

**Table 37: LVDS Output Drivers Enable**

LDEN1	LDENO	Description
0	0	Both LVDS Channel A and B are Off
0	1	LVDS Channel A is 'On' and B is 'Off'
1	0	LVDS Channel A is 'Off' and B is 'On'
1	1	Both LVDS Channel A and B are 'On'

DAS[1:0] (bits 6-5) of Register OUTEN control the TV DAC (DACA and DACB ) analog switch per the following table. Refer also to Table 12: TV Output Configurations.

**Table 38: TV DAC Analog Switch Control**

DAS1	DAS0	DACA path	DACB path
0	0	Off	Off
0	1	Off	On
1	0	On	Off
1	1	On	On

LSP2 (bit 7) of Register OUTEN selects the DDC voltage translation buffer output as follows:

- 0 -> DD1 and DC1 are selected, DD2 and DC2 are not active
- > DD2 and DC2 are selected, DD1 and DC1 are not active

**LVDS Output Driver Amplitude control**

**Symbol: LODA**  
**Address: 74h**  
**Bits: 8**

BIT:	7	6	5	4	3	2	1	0
SYMBOL:	LODP	LODPE	L2ODA2	L2ODA1	L2ODA0	L1ODA2	L1ODA1	L1ODA0
TYPE:	R/W	R/W	R/W	R/W	R/W	R/W	R/W	R/W
DEFAULT:	1	1	0	0	0	0	0	0

L1ODA[2:0] (bits 2-0) of Register LODA control the Output Driver Amplitude for LVDS Bank 1. See Table 39 below.

L2ODA[2:0] (bits 5-3) of Register LODA control the Output Driver Amplitude for LVDS Bank 2. See **Table 39** below.

**Table 39: LVDS Output Driver Amplitude**

LxODA2	LxODA1	LxODA0	Output Driver Amplitude (mV)
0	0	0	305
0	0	1	285
0	1	0	265
0	1	1	245
1	0	0	225
1	0	1	410
1	1	0	370
1	1	1	330

LODPE (bit 6) of Register LODA controls LVDS Output Driver Pre-Emphasis for both LDC[6:4] and LDC[2:0] by simultaneous Pull-up and Pull-down diode currents.

- LODPE = 0 => Pull up reduced by 33% and pull down reduced by 66%.
- LODPE = 1 => Default value

LODP (bit 7) of Register LODA activates the LVDS Outputs Driver Pull-Down during power-down.

- LODP = 0 => Pull-down devices not active
- LODP = 1 => Pull-down devices active

**LVDS PLL EMI Reduction Control**

**Symbol: LPSSC**  
**Address: 75h**  
**Bits: 1**

BIT:	7	6	5	4	3	2	1	0
SYMBOL:	LODST	Reserved	Reserved	Reserved	Reserved	Reserved	Reserved	Reserved
TYPE:	R/W	R/W	R/W	R/W	R/W	R/W	R/W	R/W
DEFAULT:	0	0	0	0	0	0	0	0

LODST (bit 7) of Register LPSSC controls the LVDS Output Drive Source Termination.

- LODST = 0 => 100Ω (typ.) shunt disabled between LVDS outputs LDCx and LDCx\*, also LLxC and LLxC\*
- LODST = 1 => 100Ω (typ.) shunt enabled between LVDS outputs LDCx and LDCx\*, also LLxC and LLxC\*



**LVDS Power Down & Loop Filter Resister**

**Symbol:** LPDLFR  
**Address:** 76h  
**Bits:** 5

BIT:	7	6	5	4	3	2	1	0
SYMBOL:	FRSTB	Reserved	Reserved	Reserved	LPPDN	LPPRB	LODPDB1	LODPDB0
TYPE:	R/W	R/W	R/W	R/W	R/W	R/W	R/W	R/W
DEFAULT:	1	0	1	0	1	1	0	1

LODPDB[1:0] (bits 1-0) of Register LPDLFR control the LVDS Output Power Down per the following table:

**Table 40: LVDS Output Power Down**

LODPDB1	LODPDB0	LDC[6:4] & LL2C , LL2C* path	LDC[2:0] , LL1C & LL1C* path
0	0	Power Down <sup>1</sup>	Power Down <sup>1</sup>
0	1	Power Down <sup>1</sup>	Power On
1	0	Power On	Power Down <sup>1</sup>
1	1	Power On	Power On

Note 1: Outputs are tri-stated in power down mode unless LODP (address 74h, bit 7) is '1', in which case outputs are pulled to ground.

LPPRB (bit 2) of Register LPDLFR controls the LVDS PLL Reset.

- LPPRB = 0 => LVDS PLL is reset
- LPPRB = 1 => Normal operation

LPPDN (bit 3) of Register LPDLFR controls the LVDS PLL Power Down.

- LPPDN = 0 => LVDS PLL is powered down
- LPPDN = 1 => Normal operation

FRSTB (bit 7) of Register LPDLFR controls the FIFO reset.

- FRSTB = 0 => Enable FIFO Reset
- FRSTB = 1 => Normal Operation

**LVDS Control 2**

**Symbol:** LVCTL2  
**Address:** 78h  
**Bits:** 7

BIT:	7	6	5	4	3	2	1	0
SYMBOL:	Reserved	LPLF4	LPLF3	LPPD4	LPPD3	LPPD2	LPPD1	LPPD0
TYPE:	R/W	R/W	R/W	R/W	R/W	R/W	R/W	R/W
DEFAULT:	0	0	1	1	1	0	0	0

LPPD[4:0] (bits 4-0) of Register LVCTL2 define the LVDS PLL Phase Detector Control. The recommended values are shown in **Table 41** in **Section 4.3**.

LPLF[4:3] (bits 6-5) of Register LVCTL2 control the LVDS PLL Loop Filter Capacitor. The recommended settings are shown in **Table 41**.



**Bang Limit Control****Symbol: BGLMT****Address: 7Fh****Bits: 8**

BIT:	7	6	5	4	3	2	1	0
SYMBOL:	BGLMT7	BGLMT6	BGLMT5	BGLMT4	BGLMT3	BGLMT2	BGLMT1	BGLMT0
TYPE:	R/W	R/W	R/W	R/W	R/W	R/W	R/W	R/W
DEFAULT:	0	0	0	1	0	0	0	0

This Register limits the allowable occurrences of internal LVDS FIFO over and under-runs within one VGA frame.



**4.3 Recommended Settings**

The recommended values for the LVDS PLL are shown in **Table 41** below.

**Table 41: LVDS Divider Control Settings**

25MHz to 50MHz operation

Address/Bit	7	6	5	4	3	2	1	0
71h			1	0	1	1	0	1
72h			1	0	0	0	1	1
73h						0	0	0
78h		0	1	0	0	0	0	0

50MHz to 100MHz operation

Address/Bit	7	6	5	4	3	2	1	0
71h			1	0	1	1	0	1
72h			1	0	0	0	1	1
73h						0	0	0
78h		0	1	0	0	0	0	0

100MHz to 160MHz operation (dual panel)

Address/Bit	7	6	5	4	3	2	1	0
71h			1	0	0	0	1	1
72h			1	0	1	1	0	1
73h						0	1	1
78h		1	1	0	0	0	0	0

100MHz to 160MHz operation (single panel)

Address/Bit	7	6	5	4	3	2	1	0
71h			1	0	0	0	1	1
72h			0	1	1	1	0	1
73h						0	1	1
78h		1	1	0	0	0	0	0



**5.0 Electrical Specifications**

**5.1 Absolute Maximum Ratings**

Symbol	Description	Min	Typ	Max	Units
	All power supplies relative to GND	-0.5		5.0	V
	Input voltage of all digital pins	GND – 0.5		VDD + 0.5	V
T <sub>SC</sub>	Analog output short circuit duration		Indefinite		Sec
T <sub>AMB</sub>	Ambient operating temperature	0		85	°C
T <sub>STOR</sub>	Storage temperature	-65		150	°C
T <sub>J</sub>	Junction temperature			150	°C
T <sub>VPS</sub>	Vapor phase soldering (5 second )			260	°C
	Vapor phase soldering (11 second )			245	°C
	Vapor phase soldering (60 second )			225	°C

**Note:**

- 1) Stresses greater than those listed under absolute maximum ratings may cause permanent damage to the device. These are stress ratings only. Functional operation of the device at these or any other conditions above those indicated under the normal operating condition of this specification is not recommended. Exposure to absolute maximum rating conditions for extended periods may affect reliability. The temperature requirements of vapor phase soldering apply to all standard and lead free parts.
- 2) The device is fabricated using high-performance CMOS technology. It should be handled as an ESD sensitive device. Voltage on any signal pin that exceeds the power supply voltages by more than ± 0.5V can induce destructive latchup.

**5.2 Recommended Operating Conditions**

Symbol	Description	Min	Typ	Max	Units
TVPLL_VDD	TV PLL Digital Power Supply Voltage	3.1	3.3	3.6	V
TVPLL_VCC	TV PLL Analog Power Supply Voltage	3.1	3.3	3.6	V
DAC_VDD	DAC Power Supply Voltage	3.1	3.3	3.6	V
LPLL_VDD	LVDS PLL Power Supply Voltage	3.1	3.3	3.6	V
DVDD	Digital Power Supply Voltage	3.1	3.3	3.6	V
LVDD	LVDS Power Supply Voltage	3.1	3.3	3.6	V
VDD	Generic for all of the above supplies	3.1	3.3	3.6	V
VDDV	I/O Power Supply Voltage	1.1	1.8	3.6	V
V5V	5V Supply for H/VOUT	4.75	5	5.25	V
R <sub>L</sub>	Output load to DAC Outputs		37.5		Ω



**5.3 Electrical Characteristics (Operating Conditions:  $T_A = 0^{\circ}\text{C} - 70^{\circ}\text{C}$ ,  $V_{DD} = 3.3\text{V} \pm 5\%$ )**

Symbol	Description	Min	Typ	Max	Units
	Video D/A Resolution	10	10	10	bits
	Full scale output current		33.9		mA
	Video level error			10	%
$I_{VDD}$	Gang Mode @ 165MHz (TV path and upscaler off)		412		mA
$I_{VDD}$	Total supply current 1 DVO input for TV @ 70 MHz 1 DVO input for LVDS @ 165 MHz LVDS output @ 165 MHz (with upscaler)		530		mA
$I_{VDD}$	Total supply current 1 DVO input for TV @ 70 MHz 1 DVO input for LVDS @ 165 MHz LVDS output @ 165 MHz (w/o upscaler)		400		mA
$I_{VDD}$	Total supply current 1 DVO input for TV @ 70 MHz 1 DVO input for LVDS @ 108MHz LVDS output @ 108 MHz		360		mA
$I_{VDDV}$	VDDV (1.8V) current (15pF load)		4		mA
$I_{PD}$	Total Power Down Current		0.06		mA





**5.4 Digital Inputs / Outputs**

Symbol	Description	Test Condition	Min	Typ	Max	Unit
V <sub>SDOL</sub>	SPD (serial port data) Output Low Voltage	I <sub>OL</sub> = 2.0 mA			0.4	V
V <sub>SPIH</sub>	Serial Port (SPC, SPD) Input High Voltage		1.0		VDD + 0.5	V
V <sub>SPI L</sub>	Serial Port (SPC, SPD) Input Low Voltage		GND-0.5		0.4	V
V <sub>HYS</sub>	Hysteresis of Inputs		0.25			V
V <sub>DATAIH</sub>	D[0-11] Input High Voltage		Vref1+0.25		DVDD+0.5	V
V <sub>DATAIL</sub>	D[0-11] Input Low Voltage		GND-0.5		Vref1-0.25	V
V <sub>MISCAIH</sub>	GPIO, AS, RESET* Input High Voltage	DVDD=3.3V	2.7		VDD + 0.5	V
V <sub>MISCAIL</sub>	GPIO, AS, RESET* Input Low Voltage	DVDD=3.3V	GND-0.5		0.6	V
I <sub>MISCAPU</sub>	Pull Up Current (GPIO, AS, RESET*)	V <sub>IN</sub> = 0V	0.5		5	uA
I <sub>MISCAPD</sub>	Pull Down Current (GPIO)	V <sub>IN</sub> = 3.3V	0.5		5	uA
V <sub>MISCAOH</sub>	GPIO, ENAVDD, ENABKL, C/HSYNC, BCO/VSYNC, Hx, Vx, HPINTB Output High Voltage	I <sub>OH</sub> = -0.4mA	VDD-0.2			V
V <sub>MISCAOL</sub>	GPIO, ENAVDD, ENABKL, C/HSYNC, BCO/VSYNC, Hx, Vx, HPINTB Output Low Voltage	I <sub>OL</sub> = 3.2mA			0.2	V
V <sub>MISCBOH</sub>	P-OUT, FLD/STL1, FLD/STL2 Output High Voltage	I <sub>OH</sub> = - 400 uA	VDDV-0.2			V
V <sub>MISC BOL</sub>	P-OUT, FLD/STL1, FLD/STL2 Output Low Voltage	I <sub>OL</sub> = 3.2 mA			0.2	V
V <sub>MISCCIH</sub>	HIN, VIN, HPDET Input High Voltage	DVDD=3.3V	2.7		VDD + 0.5	V
V <sub>MISCCIL</sub>	HIN, VIN, HPDET Input Low Voltage	DVDD=3.3V	GND-0.5		0.6	V
I <sub>MISCCPD</sub>	Pull Down Current (HIN, VIN, HPDET)	V <sub>IN</sub> = 3.3V	0.5		5	uA
V <sub>MISCDOH</sub>	HOUT, VOUT Output High Voltage	V5V = 5V				V
V <sub>MISCDOL</sub>	HOUT, VOUT Output Low Voltage	V5V = 5V				V

**Note :**

V<sub>DATA</sub> - refers to all digital pixel, clock, data enable and sync inputs.

V<sub>MISCA</sub> - refers to GPIOx, AS, and RESET\* inputs and GPIOx, ENAVDD, ENABKL, C/HSYNC, BCO/VSYNC, HPINTB outputs and Hx, Vx when configured as outputs (SYOTV=1).

I<sub>MISCAPD</sub> refers to the pulldown current on the GPIOx pins when pull-down is activated. See the description for register 6Dh.

V<sub>MISCB</sub> - refers to P-OUT, FLD/STL1 and FLD/STL2 outputs.

V<sub>MISCC</sub> - refers to HIN, VIN and HPDET inputs.



**5.5 AC Specifications**

Symbol	Description	Test Condition	Min	Typ	Max	Unit
$f_{XCLK}$	Input (XCLK) frequency		25		165	MHz
$t_{PIXEL}$	Pixel time period		6.06		40	ns
$DC_{XCLK}$	Input (XCLK) Duty Cycle	$T_S + T_H < 1.2ns$	30		70	%
$t_{XJIT}$	XCLK clock jitter tolerance			2		ns
$t_S$	Setup Time: D[11:0], H, V and DE to XCLK, XCLK*	XCLK = XCLK* to D[11:0], H, V, DE = Vref1	0.5			ns
$t_H$	Hold Time: D[11:0], H, V and DE to XCLK, XCLK*	D[11:0], H, V, DE = Vref1 to XCLK = XCLK*	0.5			ns
$t_R$	Pout, H and V (when configured as outputs) Output Rise Time (20% - 80%)	15pF load DVDD, VDDV = 3.3V			1.50	ns
$t_F$	Pout, H and V (when configured as outputs) Output Fall Time (20% - 80%)	15pF load VDDV = 3.3V			1.50	ns
$t_{STEP}$	De-skew time increment		50		80	ps



**5.6 LVDS Output Specifications**

The LVDS specifications meet the requirements of ANSI/EIA/TIA-644. Refer to Figure 24 for definitions of parameters.

Symbol	Description	Test Condition	Min	Typ	Max	Unit
$ V_t $	Steady State Differential Output Magnitude for logic 1	100Ω differential load	247		453	mV
$ V_t^* $	Steady State Differential Output Magnitude for logic 0	100Ω differential load	247		453	mV
$ V_t  -  V_t^* $	Steady State Magnitude of Difference between Logic 1 and 0 Outputs	100Ω differential load			50	mV
$ V_{os} $	Steady State Magnitude of Offset Voltage for Logic 1	Measured at center-tap of two 50Ω resistors connected between outputs	1.125		1.375	V
$ V_{os}^* $	Steady State Magnitude of Offset Voltage for Logic 0	Measured at center-tap of two 50Ω resistors connected between outputs	1.125		1.375	V
$ V_{os}  -  V_{os}^* $	Steady State Magnitude of Offset Difference between Logic States	Measured at center-tap of two 50Ω resistors connected between outputs			50	mV
$f_{LLC}$	LVDS Output Clock Frequency		25		$108^{-1}$	MHz
$t_{UI}$	LVDS data unit time interval	$25\text{MHz} < f_{LLC} < 108\text{MHz}$	1.3		5.7	ns
$t_R$	LVDS data rise time $t_{UI} > 5\text{ns}$ $1.3\text{ns} < t_{UI} < 5\text{ns}$	100Ω and 5pF differential load 20% -> 80% $V_{SWING}$			$0.3^* t_{UI}$ 1.5	ns ns
$t_F$	LVDS data fall time $t_{UI} > 5\text{ns}$ $1.3\text{ns} < t_{UI} < 5\text{ns}$	100Ω and 5pF differential load 80% -> 20% $V_{SWING}$			$0.3^* t_{UI}$ 1.5	ns ns
$V_{RING}$	Voltage ringing after transition	100Ω and 5pF differential load			20% $V_{SWING}$	

Note 1: Corresponds to maximum pixel rate  $f_{XCLK}$  for single channel operation. Dual channel operation is required for pixel rates greater than 108MHz.



5.7 Timing Information

Note:

In the figures and tables in the following sections XCLK, XCLK\*, D[11:0], H, V and DE refer respectively to XCLK1 and XCLK2, XCLK1\* and XCLK2\*, D1[11:0] and D2[11:0], H1 and H2, V1 and V2, DE1 and DE2.

5.7.1 LVDS Output Timing

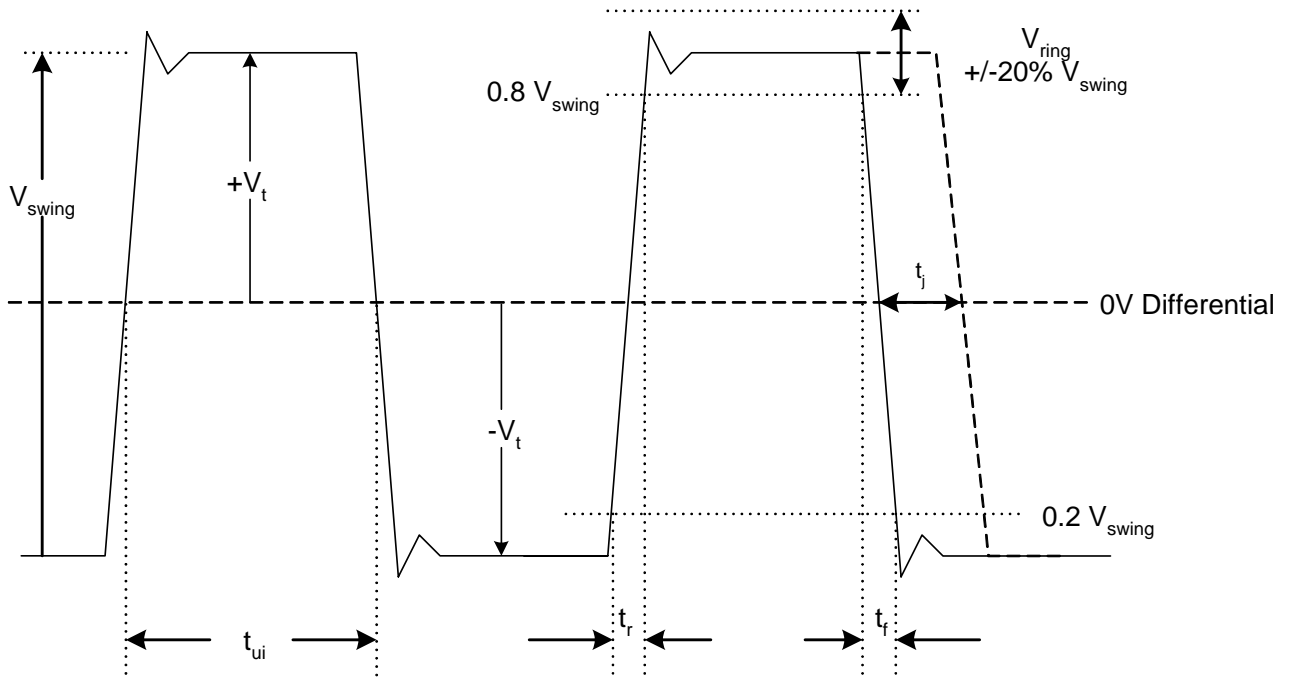

Figure 24: AC Timing for LVDS Outputs

Table 42: AC Timing for LVDS Outputs

Symbol	Parameter	Min	Typ	Max
$ V_t $	Steady State Differential Output Magnitude	see section 5.6		
$V_{SWING}$	Voltage Difference between the two Steady State Values of Output	see section 5.6		
$t_{ui}$	Unit time interval	see section 5.6		
$t_r$	Rise time	see section 5.6		
$t_f$	Fall time	see section 5.6		
$t_j$	Jitter peak to peak <sup>1</sup>			350ps

Note 1: Maximum jitter with EMI reduction turned off.



5.7.2 Clock-Slave, Sync-Slave Mode

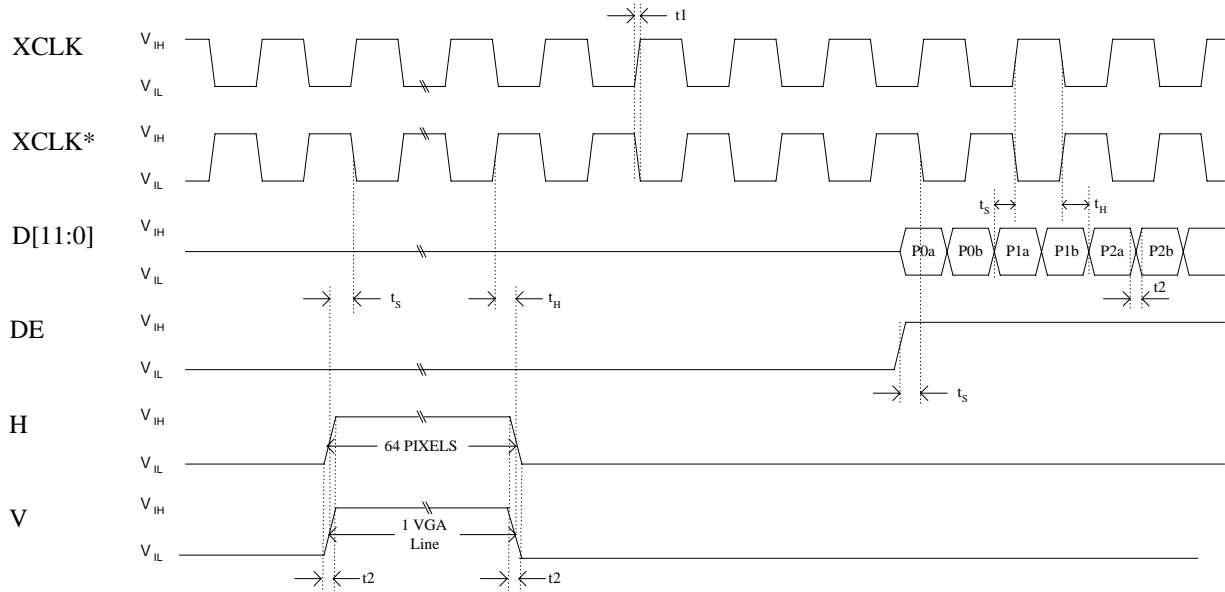

Figure 25: Timing for Clock-Slave, Sync-Slave Mode

Table 43: Timing for Clock - Slave, Sync - Slave Mode

Symbol	Parameter	Min	Typ	Max	Unit
$t_s$	Setup Time: D[11:0], H, V and DE to XCLK, XCLK*	See section 5.5			
$t_h$	Hold Time: D[11:0], H, V and DE to XCLK, XCLK*	See section 5.5			
$t_1$	XCLK & XCLK* rise/fall time w/15pF load		1		ns
$t_2$	D[11:0], H, V & DE rise/fall time w/ 15pF load		1		ns



5.7.3 Clock-Master, Sync-Slave Mode

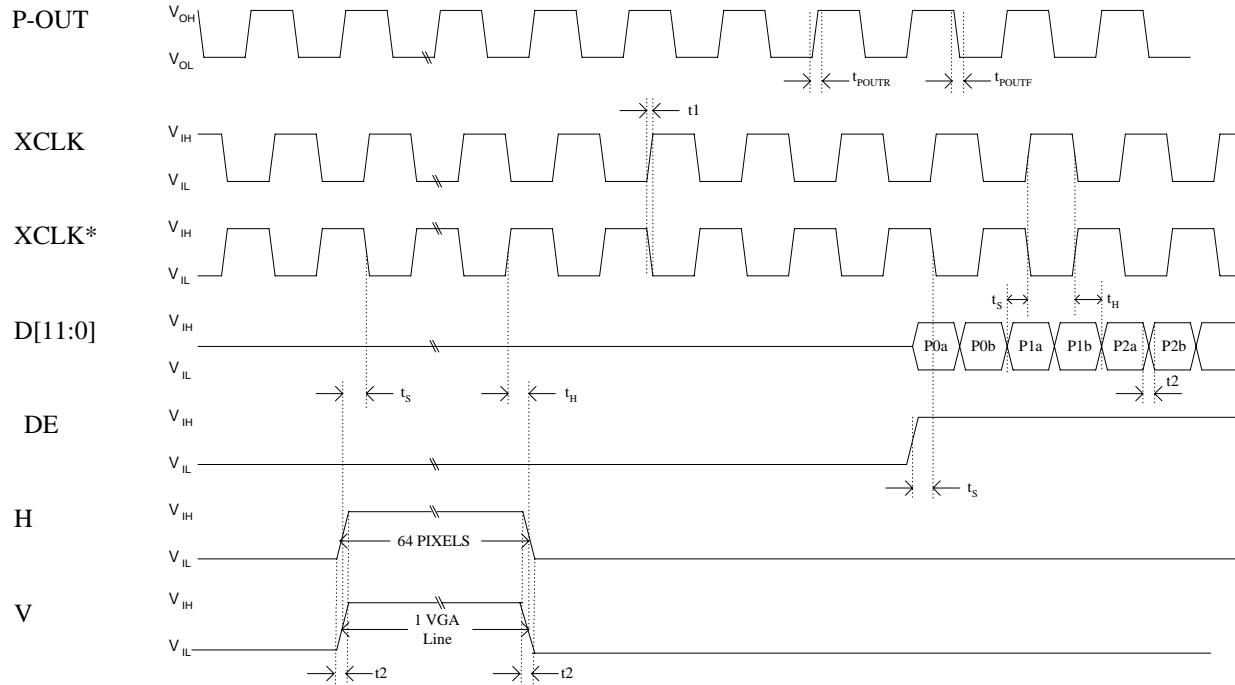

Figure 26: Timing for Clock-Master, Sync-Slave Mode

Table 44: Timing for Clock - Master, Sync - Slave Mode

Symbol	Parameter	Min	Typ	Max	Unit
t <sub>s</sub>	Setup Time: D[11:0], H, V and DE to XCLK, XCLK*	See section 5.5			
t <sub>h</sub>	Hold Time: D[11:0], H, V and DE to XCLK, XCLK*	See section 5.5			
t <sub>R</sub>	Pout Output Rise Time	See section 5.5			
t <sub>F</sub>	Pout Output Fall Time	See section 5.5			
t <sub>1</sub>	XCLK & XCLK* rise/fall time w/15pF load		1		ns
t <sub>2</sub>	D[11:0], H, V & DE rise/fall time w/15pF load		1		ns



5.5.3 Clock-Master, Sync-Master Mode

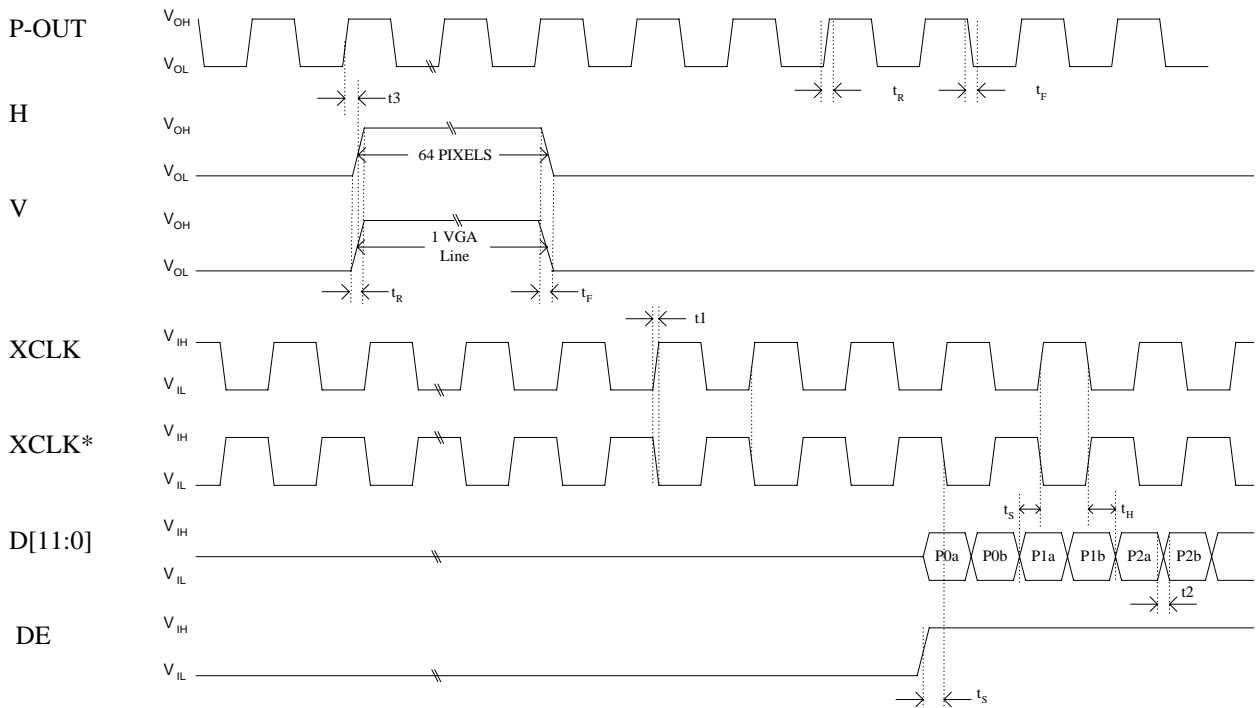

Figure 27: Clock-Master, Sync-Master Mode

Table 45: Timing for Clock - Master, Sync - Master Mode

Symbol	Parameter	Min	Typ	Max	Unit
$t_s$	Setup Time: D[11:0], H, V and DE to XCLK, XCLK*	See section 5.5			
$t_H$	Hold Time: D[11:0], H, V and DE to XCLK, XCLK*	See section 5.5			
$t_R$	Pout, H, V (when configured as outputs) Output Rise Time	See section 5.5			
$t_F$	Pout, H, V (when configured as outputs) Output Fall Time	See section 5.5			
$t_1$	XCLK & XCLK* rise/fall time w/15pF load		1		ns
$t_2$	D[11:0] & DE rise/fall time w/15pF load		1		ns
$t_3$	Hold time: P-OUT to HSYNC, VSYNC delay		1.5		ns



**6.0 Package Dimensions**

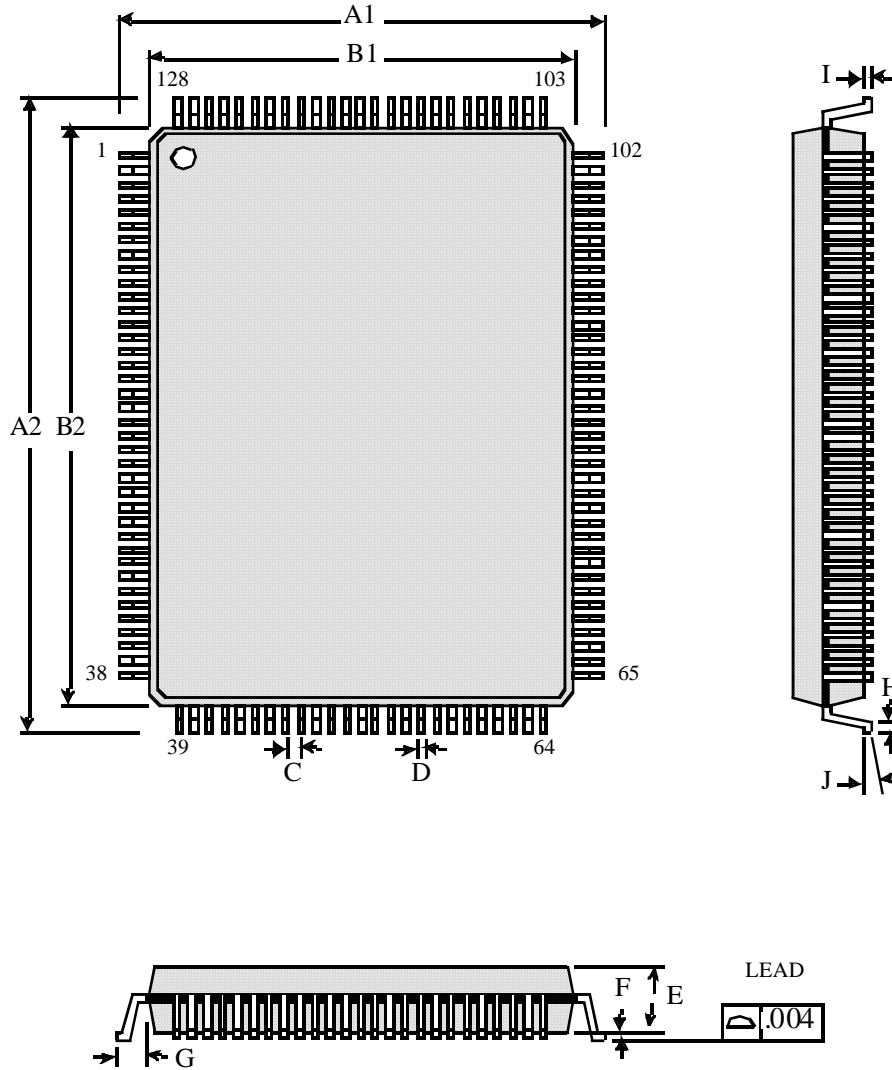

**Table of Dimensions**

No. of Leads		SYMBOL											
		A1	A2	B1	B2	C	D	E	F	G	H	I	J
128 (14X20)													
Milli-meters	MIN	16	22	14	20	0.50	0.17	1.35	0.05	1.00	0.45	0.09	0°
	MAX						0.27	1.45	0.15		0.75	0.20	7°

**Notes:**

1. Conforms to JEDEC standard JESD-30 MS-026D.
2. Dimension B: Top Package body size may be smaller than bottom package size by as much as 0.15 mm. Dimension B does not include allowable mold protrusions up to 0.25 mm per side.





7.0 Revision History

Rev. #	Date	Section	Description
1.0	1/12/02	Package Diagram	Change package to 14x20 LQFP, removed BGA.
		Pin Definition	New pin number assignments.
		VREF2 definition	Set threshold for HIN, VIN, SPC, SPD, SDC & SDD
		5.15.1	Updated register map and added index.
		5.35.3	Added registers 77h – 7Fh
		all	Multiple corrections and clarifications.
		3	Added TV-Out descriptions.
		all	Moved package description to section 5. Corrections. Added table numbers.
		6.0	Inserted electrical specs and timing diagrams
		Table 20 and 21	Added entries for 25/21 scaling
		Table 18	Added foot-note 1
1.1	5/24/02	Register 20h	Corrected description of DAC connect detect.
		Register 50h	Correct description of USMBS[4:0]
		3.2.1	Corrected Table 6 in <i>P0a</i> , <i>P0b</i> and <i>P1a</i> columns
		3.2.2	Corrected Table 8 in both <i>P0</i> columns
		3.4.2	Corrected Table 14 on <i>24-Bit OpenLDI</i> column
		Register 54h	Corrected bit assignment for IBAB[1:0]
		Register 64h	Name correction: DVSDSDC changed to LVSDSDC
		Register 76h	Correct headings in Table 44.
			Corrected default bit settings in registers 00h, 65h, 74h, 7Fh
		5.4 and 5.5	References to Vref corrected to Vref1.
		5.5.2 and 5.5.3	Correct DS to DE in figures
		Register 66h	Swapped polarity of LPLOCK
		Register 79h and 7Ah	Rearranged LPVCO[11:8] to match design.
		3.4.5	Added note about BKLEN affect on ENABKL to second paragraph.
		1.2	7/04/02
3.3.4	Corrected Note 1 in Table 11		
4.2	Added register 7Fh to customer accessible register list		
Register 63h	Changed name and symbol.		
Register 73h	Changed name and symbol		
3.4.2	Corrected bit setting for 18bit and 24bit LDI modes and added note 1.		
1.3	9/23/02	Register 48h	Added TVPLL <sub>R</sub> bit to reset TV PLL.
		Register 10h	Added 2 bits to enable FLD/STL <sub>x</sub> pins.
		2.2	Changed descriptions of the SPC, SPD and VREF2 pins
		Register 76h	LODPD bits name corrected to LODPDB (active low).
		Register 11h-13h	Changed to read only
		Table 26, 26, 27	Added hex values
		Register 5Ch	Renamed register to GPIO Invert (GPIOINV)
		0	Changed V <sub>IH</sub> and V <sub>IL</sub> . Added hysteresis. Corrected test condition for V <sub>P-OUTOH</sub> . Changed I <sub>MISCAPU</sub> and added additional outputs to spec. – FLD/STL1, FLD/STL2, C/HSYNC and BCO/VSYNC.
			Swapped descriptions for modes 8 and 9
		Register 02h	Changed default value for bit 7 (VBID).
Register 10h –13h	Changed CIV bits to read only		
Registers 1Eh and 6Dh	Changed default value and description of GPIOI <sub>x</sub> bits.		
1.4	2/06/03	4.1	Changed reference to ACIV to CIVEN.
		All	Changed all references of DVDDV to VDDV
		4.1	Moved LPLOCK and LSYNCEN in the Control Register Index from “Input/Output Controls” to “LVDS Controls”
		Various	Updated Figure 20 and Table 26 - Corrected N value for mode 11 from 64 to 62.



<b>Rev. #</b>	<b>Date</b>	<b>Section</b>	<b>Description</b>
		All	Updated Section 5.5, tables 42-44 on Timings for Clock.
1.5	6/13/03	Register 07h	Updated max and min range for black level pedestal.
	6/13/03	5.4, 5.5, and 5.6	Updated section 5.4. Added AC specifications to section 5.5. Changed format to section 5.6.
1.6	1/19/04	Table 27	Mode 42 values have been updated
		5.6, 5.7.1, Table 42	Added section 5.6, 5.7.1, and table 42
1.7	10/20/04	4	Add Vapor phase soldering information.
1.8	10/29/04	3	Typo corrections
2.0	4/17/06	All	Combined CH7017 and CH7018 datasheet.



### Disclaimer

This document provides technical information for the user. Chrontel reserves the right to make changes at any time without notice to improve and supply the best possible product and is not responsible and does not assume any liability for misapplication or use outside the limits specified in this document. We provide no warranty for the use of our products and assume no liability for errors contained in this document. The customer should make sure that they have the most recent data sheet version. Customers should take appropriate action to ensure their use of the products does not infringe upon any patents. Chrontel, Inc. respects valid patent rights of third parties and does not infringe upon or assist others to infringe upon such rights.

Chrontel PRODUCTS ARE NOT AUTHORIZED FOR AND SHOULD NOT BE USED WITHIN LIFE SUPPORT SYSTEMS OR NUCLEAR FACILITY APPLICATIONS WITHOUT THE SPECIFIC WRITTEN CONSENT OF Chrontel. Life support systems are those intended to support or sustain life and whose failure to perform when used as directed can reasonably expect to result in personal injury or death.

<b>ORDERING INFORMATION</b>			
Part Number	Package Type	Number of Pins	Voltage Supply
CH7017A-TF	LQFP, Lead free	128	3.3V
CH7017A-TF-TR	LQFP, Lead free, Tape&Reel	128	3.3V
CH7018A-TF	LQFP, Lead free	128	3.3V
CH7018A-TF-TR	LQFP, Lead free, Tape&Reel	128	3.3V

---

## Chrontel

2210 O'Toole Avenue, Suite 100,  
San Jose, CA 95131-1326  
Tel: (408) 383-9328  
Fax: (408) 383-9338  
[www.chrontel.com](http://www.chrontel.com)  
E-mail: [sales@chrontel.com](mailto:sales@chrontel.com)

