

1,310nm DFB CATV Laser

FLD3F7CZ

FEATURES

- Direct Modulation DFB Laser
- Built-in TEC, Thermistor and Monitor PD
- Optical Isolator
- 14 Pin Butterfly Type Module
- 78 Channel NTSC Loading (112 Channel device available)
- Low Residual CSO & CTB
- 11 dB Link Budget Available

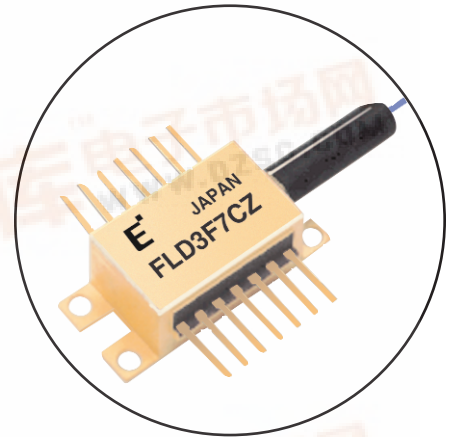

APPLICATIONS

This DFB laser is intended for application in analog AM, CATV at 1,310nm. Transmission spans of 30 km are possible without amplification.

DESCRIPTION

This DFB laser for analog AM application is a high power laser capable of carrying 78 channels with excellent CSO, CTB, and CNR performance. It is packaged in a 'butterfly' type module. The module employs a high efficiency optical coupling system, coupling the laser output through a built-in optical isolator into a single mode fiber pigtail. The module also includes a monitor photodiode, a thermoelectric cooler (TEC) and a thermistor.

ABSOLUTE MAXIMUM RATINGS (T_C=25°C, unless otherwise specified)

Parameter	Symbol	Condition	Ratings		Unit
			Min.	Max.	
Storage Temperature	T _{stg}	-	-40	+70	°C
Operating Case Temperature	T _{op}	-	-20	+65	°C
Optical Output Power	P _f	CW	-	20	mW
LD Forward Current	I _F	CW	-	150	mA
LD Reverse Voltage	V _R	-	-	2	V
PD Reverse Voltage	V _{DR}	-	-	20	V
PD Forward Current	I _{PD}	-	-	10	mA
TEC Voltage	V _C	Cooling	-	+2.5	V
		Heating	-2.0	-	
TEC Current	I _C	Cooling	-	+1.4	A
		Heating	-0.5	-	
Thermistor Temperature	T _{th}	ATC Operation	-20	+65	°C
Lead Soldering Time	T _{sold}	260°C	-	10	sec
Environmental Operating Humidity	X _{op}	Top<30°C	-	95	%
Environmental Storage Humidity	X _{st}	Tstg<30°C	-	95	%

TEC & THERMISTOR CHARACTERISTICS ($T_L=25\pm 1^\circ\text{C}$)

Parameter	Symbol	Test Conditions	Limits		Unit
			Min.	Max.	
TEC Current	I_C	$\Delta T=40^\circ\text{C}$	-	1.0	A
TEC Voltage	V_C	$\Delta T=40^\circ\text{C}$	-	2.0	V
TEC Capacity	ΔT	$I_C=1\text{A}$	40	-	$^\circ\text{C}$
Thermistor Resistance	R_{Tr}	-	9.5	10.5	$\text{k}\Omega$
Thermistor B Constant	B	-	Typ. 3,900		K

T_C = Case Temperature, T_L = Laser Temperature

OPTICAL AND ELECTRICAL CHARACTERISTICS ($T_L=25\pm 1^\circ\text{C}$)

Parameter	Symbol	Test Conditions	Limits		Unit
			Min.	Max.	
Threshold Current	I_{th}	CW	-	20	mA
Forward Voltage (pin 3-13)	V_F	CW, $I_F=30\text{mA}$	-	1.5	V
Optical Output Power	P_f	CW	8	20	mW
Slope Efficiency	S	CW, $I_F=I_{op}$	0.20	-	mW/mA
Tracking Error	T_E	Note (1)	-0.5	+0.5	dB
Monitor Current	I_m	CW, $I_F=I_{op}$, $V_{DR}=5\text{V}$	30	900	μA
Photodiode Dark Current	I_d	$V_{DR}=5\text{V}$	-	100	nA
Photodiode Capacitance	C_t	$V_{DR}=5\text{V}$, $f=1\text{MHz}$	-	12	pF
Peak Wavelength	λ_p	CW, $I_F=I_{op}$	1,290	1,330	nm
SideMode Suppression Ratio	SSR	CW, $I_F=I_{op}$	25	-	dB
Bandwidth (-1dB)	f_c	Note (2)	1.5	-	GHz
Isolation	I_s	$T_c=0$ to 65°C	25	-	dB
Relative Intensity Noise	RIN	Note (3)	-	-155	dB/Hz
Composite Second Power	CSO	Note (4)	-	-57	dBc
Composite Triple Beat	CTB		-	-65	dBc
Carrier to Noise Ratio	CNR		50	-	dB

(1) Total change in P_f over $-20 < T_c < +65^\circ\text{C}$, Test conditions: $P_f=8\text{mW}$ at $T_L=T_c=25^\circ\text{C}$. Constant current operation with TEC operating.

(2) Test condition: $P_f=8\text{mW}$, No matching network is used in the measurement.

(3) Test condition: P_f ; same power of Note 4, measuring bandwidth: 45-600MHz, Optical reflection=-40dB (no long-haul fiber is used in the measurement.)

(4) Test condition: $P_f=8\text{mW}$ (minimum), Optical Modulation, Index=3.2%/channel (minimum), 78 unmodulated carriers (55.25 to 547.25 MHz; ch. 2 to 78 plus A-1), Optical link loss=11dB (30 km singlemode fiber), Noise equivalent current of 1st stage of the receiver= $7\text{pA}/\sqrt{\text{Hz}}$, Receiver responsivity=0.86A/W, Optical reflection=-40dB (excluding reflection from long-haul fiber).



Fig. 1 Optical Output Power and Monitor Current vs. Laser Forward Current

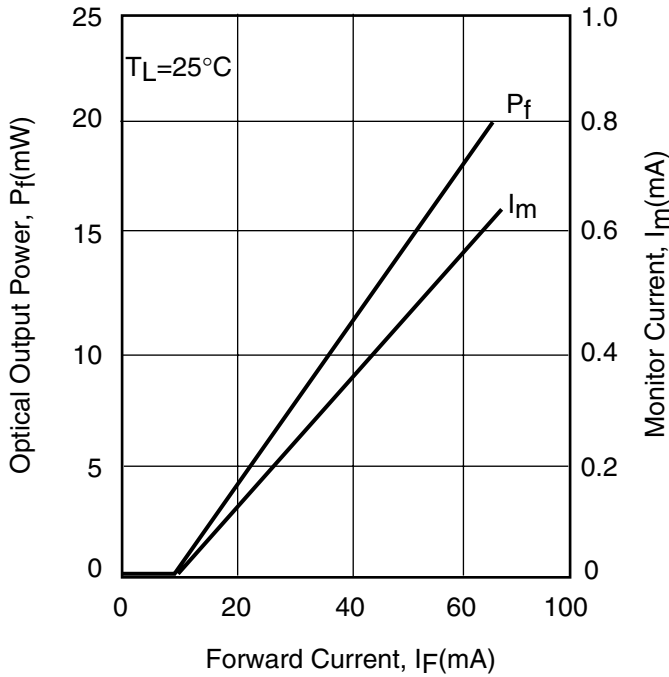

Fig. 2 Forward Current vs. Forward Voltage

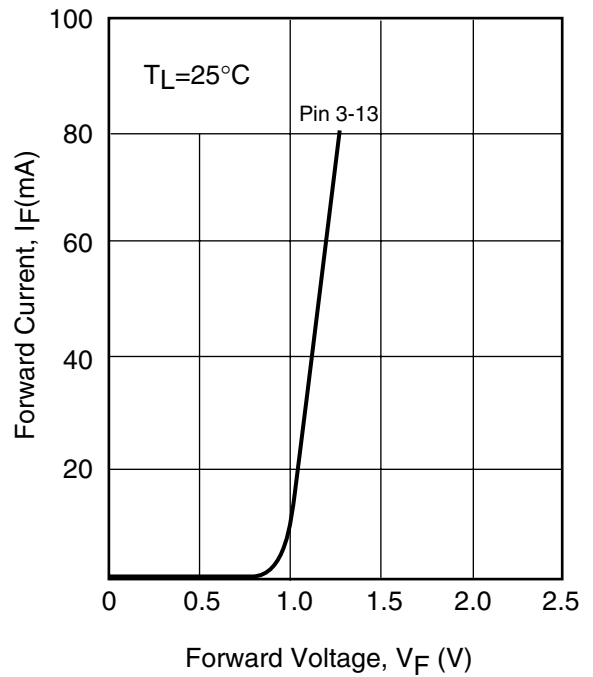

Fig. 3 Temperature Dependence of Threshold Current

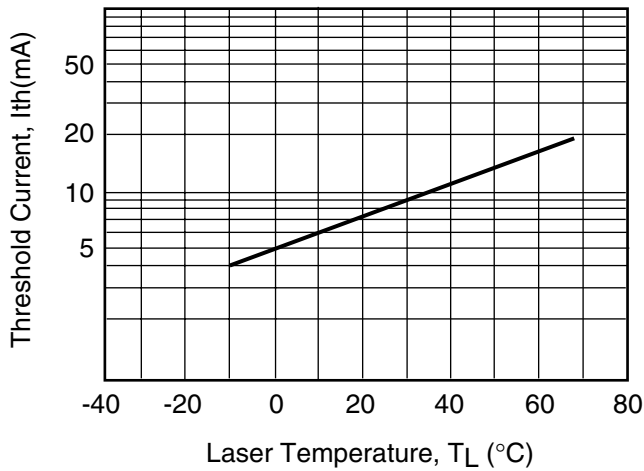

Fig. 4 Lasing Spectrum

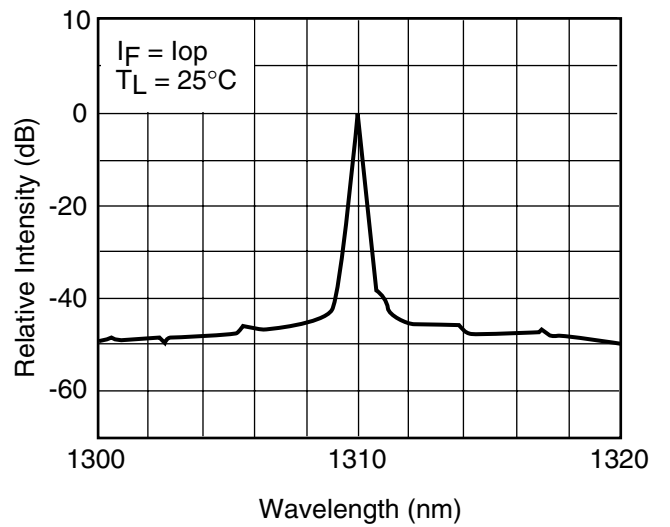

Fig. 5 Tracking Characteristics

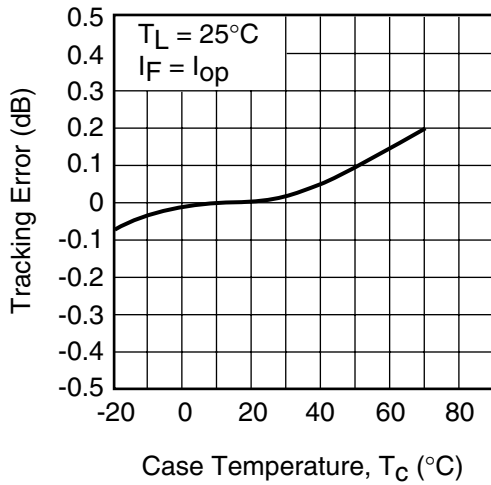

Fig. 6 Frequency Response

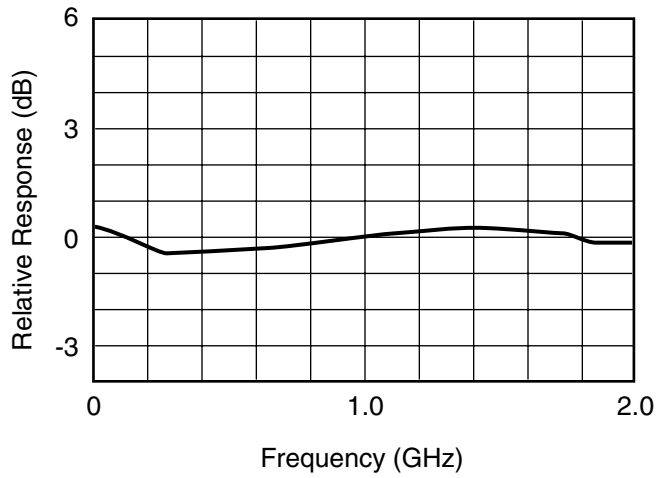

Fig. 7 RIN Characteristics

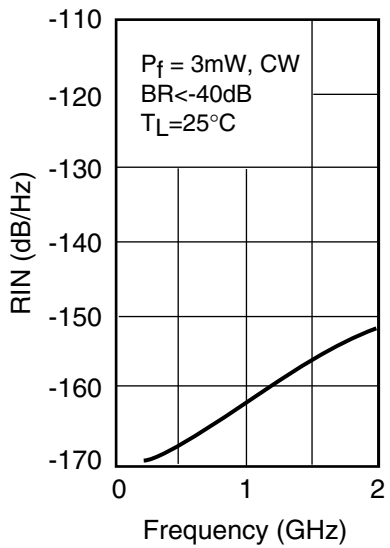

Fig. 8 Thermistor Resistance vs. Temperature

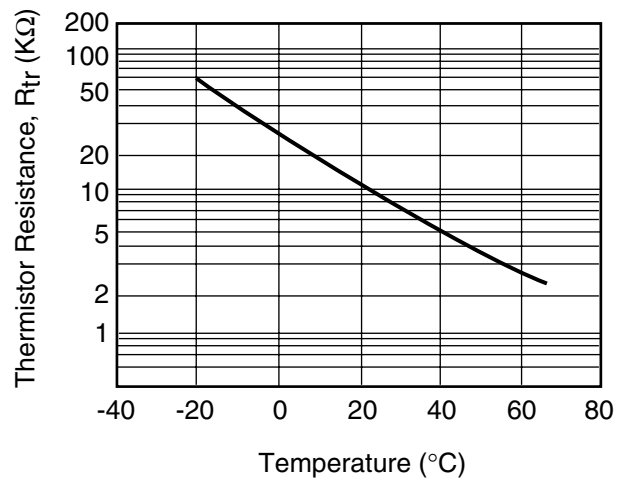

Fig. 9 Cooler voltage and Cooler Current vs. Case Temperature

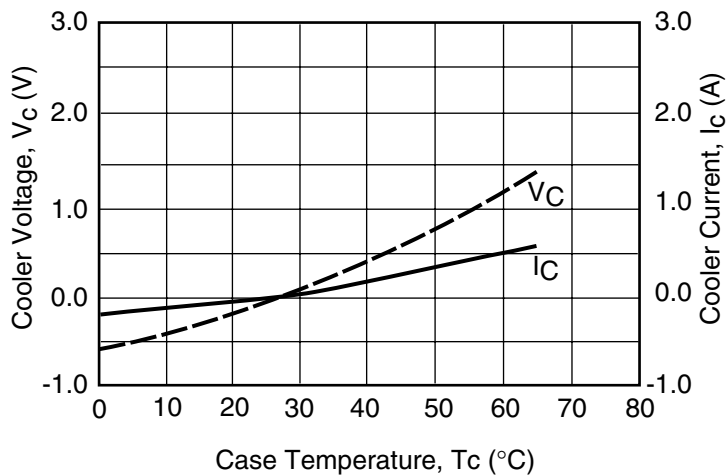

Fig. 10 CSO vs. Output Power

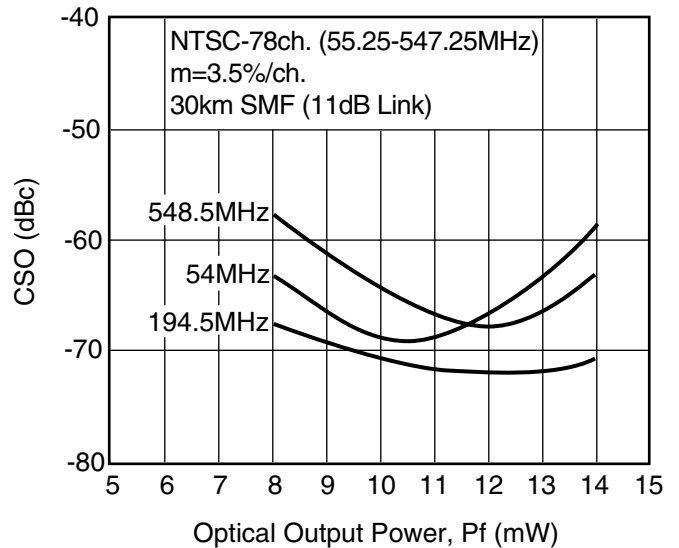

Fig. 11 CTB vs. Output Power

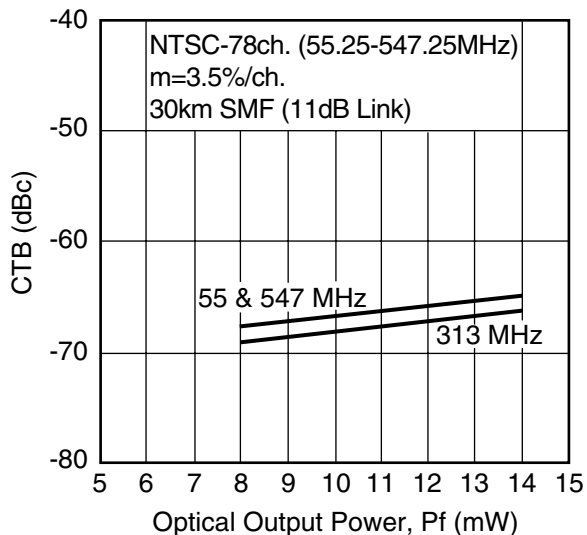
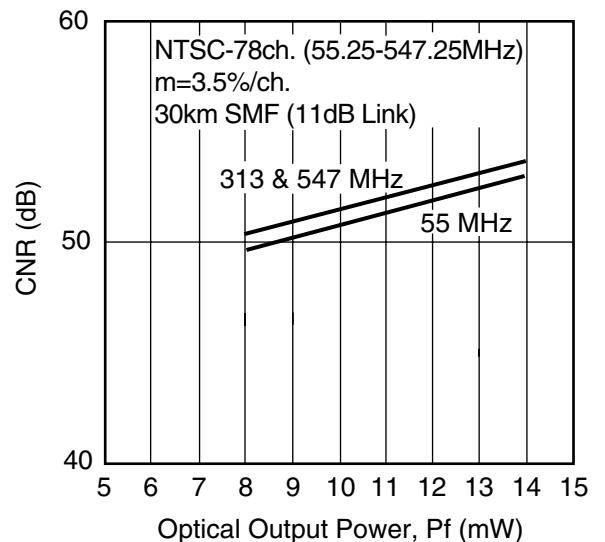

Fig. 12 CNR vs. Output Power



FLD3F7CZ

1,310nm DFB CATV Laser

"CZ" PACKAGE

UNIT: mm

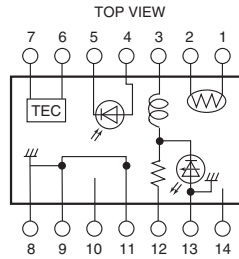
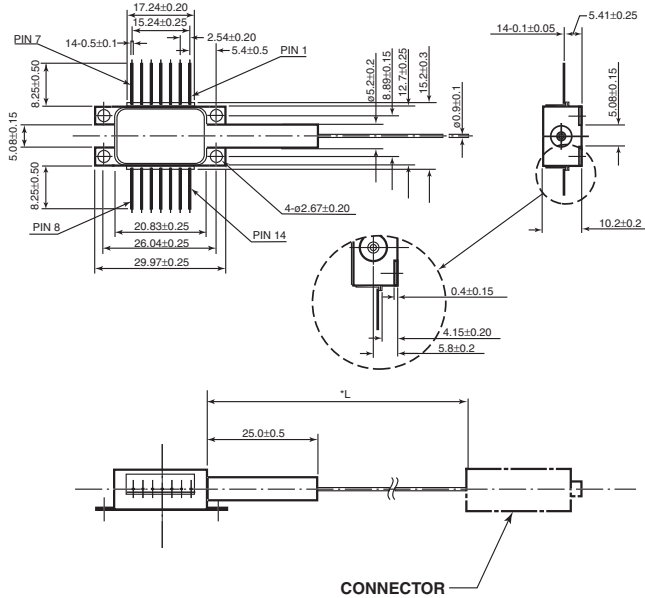

#	PIN DESIGNATIONS
1	Thermistor
2	Thermistor
3	LD Cathode
4	Power Monitor Anode
5	Power Monitor Cathode
6	Thermoelectric Cooler (+)
7	Thermoelectric Cooler (-)
8	Case Ground
9	Case Ground
10	NC
11	Case Ground
12	LD Modulation (-)
13	Case Ground
14	NC

Case Ground: LD Anode

* Pigtail length (L) and connector type are specified in the detail (individual) specification.

For further information please contact:

Eudyna Devices USA Inc.

2355 Zanker Rd.
San Jose, CA 95131-1138, U.S.A.
TEL: (408) 232-9500
FAX: (408) 428-9111
www.us.eudyna.com

Eudyna Devices Europe Ltd.

Network House
Norreys Drive
Maidenhead, Berkshire SL6 4FJ
United Kingdom
TEL: +44 (0) 1628 504800
FAX: +44 (0) 1628 504888

Eudyna Devices Asia Pte Ltd.

Hong Kong Branch
Rm. 1101, Ocean Centre, 5 Canton Rd.
Tsim Sha Tsui, Kowloon, Hong Kong
TEL: +852-2377-0227
FAX: +852-2377-3921

Eudyna Devices Inc.

Sales Division
1, Kanai-cho, Sakae-ku
Yokohama, 244-0845, Japan
TEL: +81-45-853-8156
FAX: +81-45-853-8170

CAUTION

Eudyna Devices Inc. products contain **gallium arsenide (GaAs)** which can be hazardous to the human body and the environment. For safety, observe the following procedures:

- Do not put this product into the mouth.
- Do not alter the form of this product into a gas, powder, or liquid through burning, crushing, or chemical processing as these by-products are dangerous to the human body if inhaled, ingested, or swallowed.
- Observe government laws and company regulations when discarding this product. This product must be discarded in accordance with methods specified by applicable hazardous waste procedures.

Eudyna Devices Inc. reserves the right to change products and specifications without notice. The information does not convey any license under rights of Eudyna Devices Inc. or others.

© 2004 Eudyna Devices USA Inc.
Printed in U.S.A.

