

**OPA350**  
**OPA2350**  
**OPA4350**

For most current data sheet and other product information, visit [www.burr-brown.com](http://www.burr-brown.com)

# High-Speed, Single-Supply, Rail-to-Rail OPERATIONAL AMPLIFIERS

## MicroAmplifier™ Series

### FEATURES

- RAIL-TO-RAIL INPUT
- RAIL-TO-RAIL OUTPUT (within 10mV)
- WIDE BANDWIDTH: 38MHz
- HIGH SLEW RATE: 22V/μs
- LOW NOISE: 5nV/√Hz
- LOW THD+NOISE: 0.0006%
- UNITY-GAIN STABLE
- MicroSIZE PACKAGES
- SINGLE, DUAL, AND QUAD

### APPLICATIONS

- CELL PHONE PA CONTROL LOOPS
- DRIVING A/D CONVERTERS
- VIDEO PROCESSING
- DATA ACQUISITION
- PROCESS CONTROL
- AUDIO PROCESSING
- COMMUNICATIONS
- ACTIVE FILTERS
- TEST EQUIPMENT

### DESCRIPTION

OPA350 series rail-to-rail CMOS operational amplifiers are optimized for low voltage, single-supply operation. Rail-to-rail input/output, low noise (5nV/√Hz), and high speed operation (38MHz, 22V/μs) make them ideal for driving sampling analog-to-digital converters. They are also well suited for cell phone PA control loops and video processing (75Ω drive capability) as well as audio and general purpose applications. Single, dual, and quad versions have identical specifications for maximum design flexibility.

The OPA350 series operates on a single supply as low as 2.5V with an input common-mode voltage range that

extends 300mV below ground and 300mV above the positive supply. Output voltage swing is to within 10mV of the supply rails with a 10kΩ load. Dual and quad designs feature completely independent circuitry for lowest crosstalk and freedom from interaction.

The single (OPA350) and dual (OPA2350) come in the miniature MSOP-8 surface mount, SO-8 surface mount, and 8-pin DIP packages. The quad (OPA4350) packages are the space-saving SSOP-16 surface mount and SO-14 surface mount. All are specified from -40°C to +85°C and operate from -55°C to +125°C.

SPICE Model available at [www.burr-brown.com](http://www.burr-brown.com)

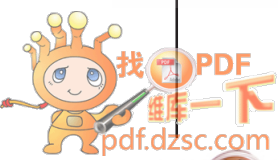
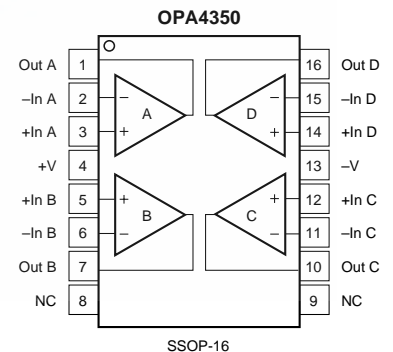
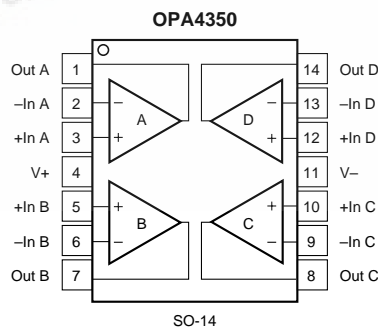
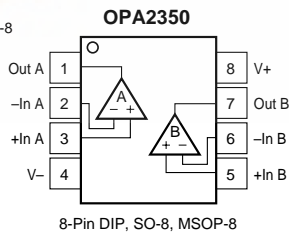
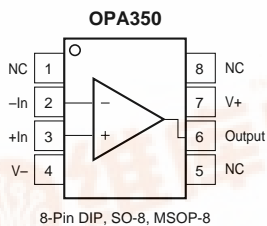

# SPECIFICATIONS: $V_S = 2.7V$ to $5.5V$

At  $T_A = +25^\circ C$ ,  $R_L = 1k\Omega$  connected to  $V_S/2$  and  $V_{OUT} = V_S/2$ , unless otherwise noted.  
**Boldface** limits apply over the specified temperature range,  $T_A = -40^\circ C$  to  $+85^\circ C$ .  $V_S = 5V$ .

PARAMETER	CONDITION	OPA350EA, UA, PA OPA2350EA, UA, PA OPA4350EA, UA			UNITS
		MIN	TYP <sup>(1)</sup>	MAX	
<b>OFFSET VOLTAGE</b> Input Offset Voltage $V_{OS}$ $T_A = -40^\circ C$ to $+85^\circ C$ vs Temperature vs Power Supply Rejection Ratio PSRR $T_A = -40^\circ C$ to $+85^\circ C$ Channel Separation (dual, quad)	$V_S = 5V$  $T_A = -40^\circ C$ to $+85^\circ C$ $V_S = 2.7V$ to $5.5V$ , $V_{CM} = 0V$ $V_S = 2.7V$ to $5.5V$ , $V_{CM} = 0V$ dc		$\pm 150$  $\pm 4$ 40 0.15	$\pm 500$ $\pm 1$ 150 175	$\mu V$ mV $\mu V/^\circ C$ $\mu V/V$ $\mu V/V$
<b>INPUT BIAS CURRENT</b> Input Bias Current $I_B$ vs Temperature Input Offset Current $I_{OS}$			$\pm 0.5$ See Typical Performance Curve $\pm 0.5$	$\pm 10$ $\pm 10$	pA pA
<b>NOISE</b> Input Voltage Noise, $f = 100Hz$ to $400kHz$ Input Voltage Noise Density, $f = 10kHz$ $f = 100kHz$ Current Noise Density, $f = 10kHz$			4 7 5 4		$\mu V_{rms}$ $nV/\sqrt{Hz}$ $nV/\sqrt{Hz}$ $fA/\sqrt{Hz}$
<b>INPUT VOLTAGE RANGE</b> Common-Mode Voltage Range $V_{CM}$ Common-Mode Rejection Ratio CMRR  $T_A = -40^\circ C$ to $+85^\circ C$	$T_A = -40^\circ C$ to $+85^\circ C$ $V_S = 2.7V$ , $-0.1V < V_{CM} < 2.8V$ $V_S = 5.5V$ , $-0.1V < V_{CM} < 5.6V$ $V_S = 5.5V$ , $-0.1V < V_{CM} < 5.6V$	<b>-0.1</b> 66 76 74		<b>(V+)+0.1</b>	V dB dB dB
<b>INPUT IMPEDANCE</b> Differential Common-Mode			$10^{13} \parallel 2.5$ $10^{13} \parallel 6.5$		$\Omega \parallel pF$ $\Omega \parallel pF$
<b>OPEN-LOOP GAIN</b> Open-Loop Voltage Gain $A_{OL}$ $T_A = -40^\circ C$ to $+85^\circ C$  $T_A = -40^\circ C$ to $+85^\circ C$	$R_L = 10k\Omega$ , $50mV < V_O < (V+) - 50mV$ <b><math>R_L = 10k\Omega</math>, <math>50mV &lt; V_O &lt; (V+) - 50mV</math></b> $R_L = 1k\Omega$ , $200mV < V_O < (V+) - 200mV$ <b><math>R_L = 1k\Omega</math>, <math>200mV &lt; V_O &lt; (V+) - 200mV</math></b>	100 <b>100</b> 100 <b>100</b>	122  120		dB dB dB dB
<b>FREQUENCY RESPONSE</b> Gain-Bandwidth Product GBW Slew Rate SR Settling Time, 0.1% 0.01% Overload Recovery Time Total Harmonic Distortion + Noise THD+N Differential Gain Error Differential Phase Error	$C_L = 100pF$ $G = 1$ $G = 1$ $G = \pm 1$ , 2V Step $G = \pm 1$ , 2V Step $V_{IN} \cdot G = V_S$ $R_L = 600\Omega$ , $V_O = 2.5V_{p-p}^{(2)}$ , $G = 1$ , $f = 1kHz$ $G = 2$ , $R_L = 600\Omega$ , $V_O = 1.4V^{(3)}$ $G = 2$ , $R_L = 600\Omega$ , $V_O = 1.4V^{(3)}$		38 22 0.22 0.5 0.1 0.0006 0.17 0.17		MHz V/ $\mu s$ $\mu s$ $\mu s$ $\mu s$ % % deg
<b>OUTPUT</b> Voltage Output Swing from Rail <sup>(4)</sup> $V_{OUT}$ $T_A = -40^\circ C$ to $+85^\circ C$  $T_A = -40^\circ C$ to $+85^\circ C$ Output Current $I_{OUT}$ Short-Circuit Current $I_{SC}$ Capacitive Load Drive $C_{LOAD}$	$R_L = 10k\Omega$ , $A_{OL} \geq 100dB$ <b><math>R_L = 10k\Omega</math>, <math>A_{OL} \geq 100dB</math></b> $R_L = 1k\Omega$ , $A_{OL} \geq 100dB$ <b><math>R_L = 1k\Omega</math>, <math>A_{OL} \geq 100dB</math></b>		10  25  $\pm 40^{(5)}$ $\pm 80$ See Typical Curve	50 <b>50</b> 200 <b>200</b>	mV mV mV mV mA mA
<b>POWER SUPPLY</b> Operating Voltage Range $V_S$ Minimum Operating Voltage Quiescent Current (per amplifier) $I_Q$ $T_A = -40^\circ C$ to $+85^\circ C$	$T_A = -40^\circ C$ to $+85^\circ C$  $I_Q = 0$ $I_Q = 0$	<b>2.7</b>		<b>5.5</b> 2.5 5.2 7.5 8.5	V V mA mA
<b>TEMPERATURE RANGE</b> Specified Range Operating Range Storage Range Thermal Resistance $\theta_{JA}$ MSOP-8 Surface Mount SO-8 Surface Mount 8-Pin DIP SO-14 Surface Mount SSOP-16 Surface Mount		-40 -55 -55		+85 +125 +125	$^\circ C$ $^\circ C$ $^\circ C$ $^\circ C/W$ $^\circ C/W$ $^\circ C/W$ $^\circ C/W$ $^\circ C/W$

NOTES: (1)  $V_S = +5V$ . (2)  $V_{OUT} = 0.25V$  to  $2.75V$ . (3) NTSC signal generator used. See Figure 6 for test circuit. (4) Output voltage swings are measured between the output and power supply rails. (5) See typical performance curve, "Output Voltage Swing vs Output Current."



## ABSOLUTE MAXIMUM RATINGS<sup>(1)</sup>

Supply Voltage .....	5.5V
Signal Input Terminals, Voltage <sup>(2)</sup> .....	(V-) – 0.3V to (V+) + 0.3V
Current <sup>(2)</sup> .....	10mA
Output Short Circuit <sup>(3)</sup> .....	Continuous
Operating Temperature .....	–55°C to +125°C
Storage Temperature .....	–55°C to +125°C
Junction Temperature .....	150°C
Lead Temperature (soldering, 10s) .....	300°C

NOTES: (1) Stresses above these ratings may cause permanent damage. Exposure to absolute maximum conditions for extended periods may degrade device reliability. (2) Input terminals are diode-clamped to the power supply rails. Input signals that can swing more than 0.3V beyond the supply rails should be current-limited to 10mA or less. (3) Short circuit to ground, one amplifier per package.



## ELECTROSTATIC DISCHARGE SENSITIVITY

This integrated circuit can be damaged by ESD. Burr-Brown recommends that all integrated circuits be handled with appropriate precautions. Failure to observe proper handling and installation procedures can cause damage.

ESD damage can range from subtle performance degradation to complete device failure. Precision integrated circuits may be more susceptible to damage because very small parametric changes could cause the device not to meet its published specifications.

## PACKAGE/ORDERING INFORMATION

PRODUCT	PACKAGE	PACKAGE DRAWING NUMBER <sup>(1)</sup>	SPECIFIED TEMPERATURE RANGE	PACKAGE MARKING	ORDERING NUMBER <sup>(2)</sup>	TRANSPORT MEDIA
<b>Single</b>						
OPA350EA	MSOP-8 Surface Mount	337	–40°C to +85°C	C50	OPA350EA/250	Tape and Reel
"	"	"	"	"	OPA350EA/2K5	Tape and Reel
OPA350UA	SO-8 Surface-Mount	182	–40°C to +85°C	OPA350UA	OPA350UA	Rails
"	"	"	"	"	OPA350UA/2K5	Tape and Reel
OPA350PA	8-Pin DIP	006	–40°C to +85°C	OPA350PA	OPA350PA	Rails
<b>Dual</b>						
OPA2350EA	MSOP-8 Surface-Mount	337	–40°C to +85°C	D50	OPA2350EA/250	Tape and Reel
"	"	"	"	"	OPA2350EA/2K5	Tape and Reel
OPA2350UA	SO-8 Surface-Mount	182	–40°C to +85°C	OPA2350UA	OPA2350UA	Rails
"	"	"	"	"	OPA2350UA/2K5	Tape and Reel
OPA2350PA	8-Pin DIP	006	–40°C to +85°C	OPA2350PA	OPA2350PA	Rails
<b>Quad</b>						
OPA4350EA	SSOP-16 Surface-Mount	322	–40°C to +85°C	OPA4350EA	OPA4350EA/250	Tape and Reel
"	"	"	"	"	OPA4350EA/2K5	Tape and Reel
OPA4350UA	SO-14 Surface Mount	235	–40°C to +85°C	OPA4350UA	OPA4350UA	Rails
"	"	"	"	"	OPA4350UA/2K5	Tape and Reel

NOTES: (1) For detailed drawing and dimension table, please see end of data sheet, or Appendix C of Burr-Brown IC Data Book. (2) Models with a slash (/) are available only in Tape and Reel in the quantities indicated (e.g., /2K5 indicates 2500 devices per reel). Ordering 2500 pieces of "OPA2350EA/2K5" will get a single 2500-piece Tape and Reel. For detailed Tape and Reel mechanical information, refer to Appendix B of Burr-Brown IC Data Book.



# TYPICAL PERFORMANCE CURVES

At  $T_A = +25^\circ\text{C}$ ,  $V_S = +5\text{V}$ , and  $R_L = 1\text{k}\Omega$  connected to  $V_S/2$ , unless otherwise noted.

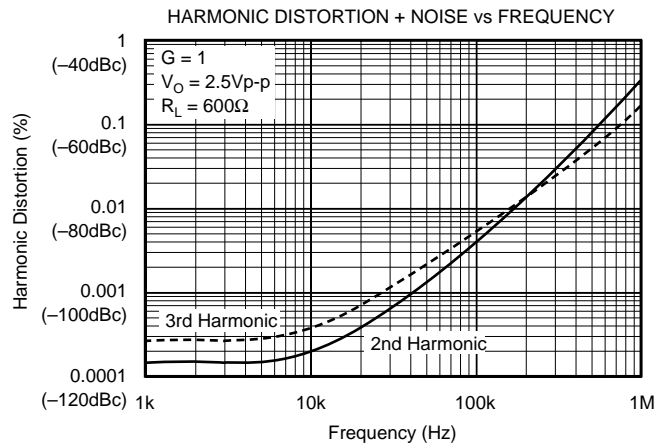
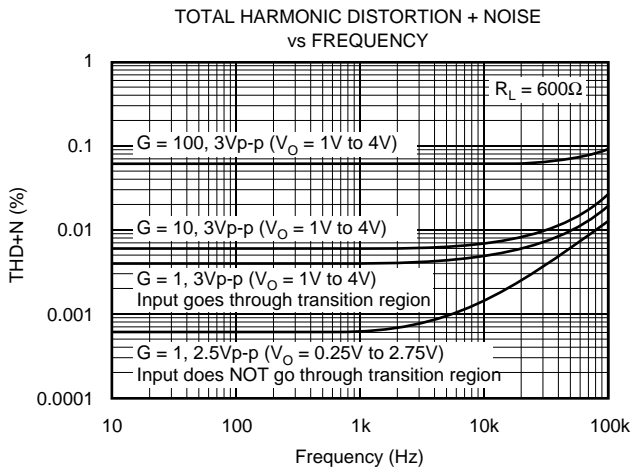
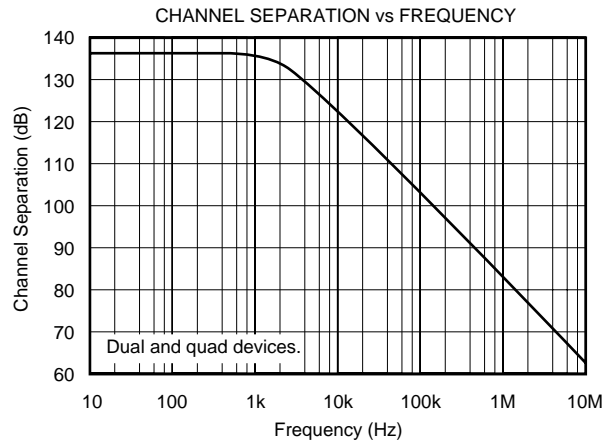
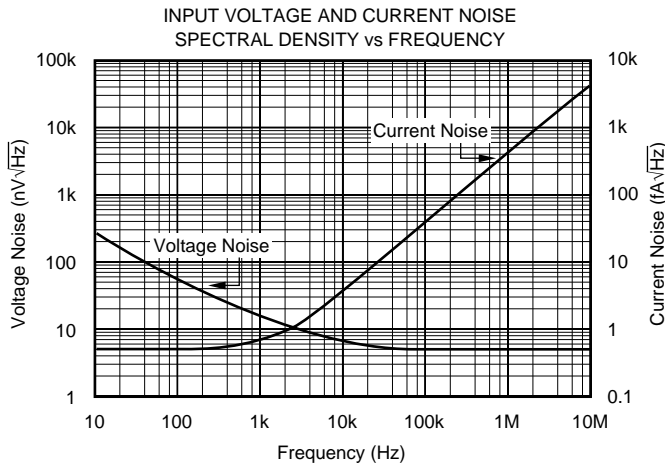
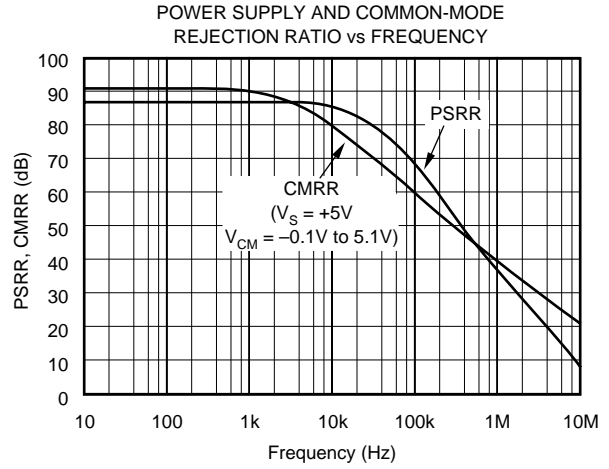
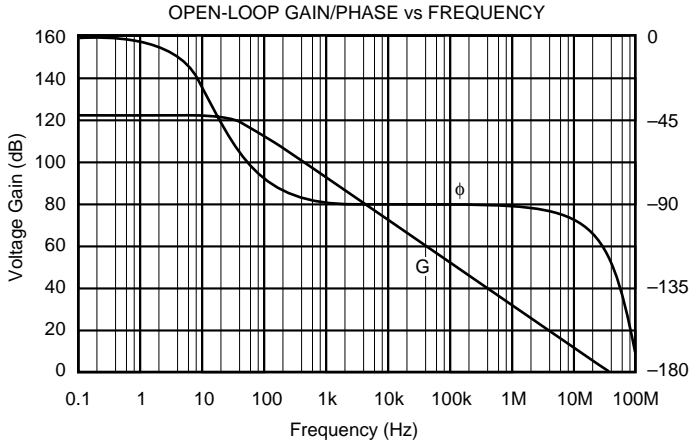

# TYPICAL PERFORMANCE CURVES (CONT)

At  $T_A = +25^\circ\text{C}$ ,  $V_S = +5\text{V}$ , and  $R_L = 1\text{k}\Omega$  connected to  $V_S/2$ , unless otherwise noted.

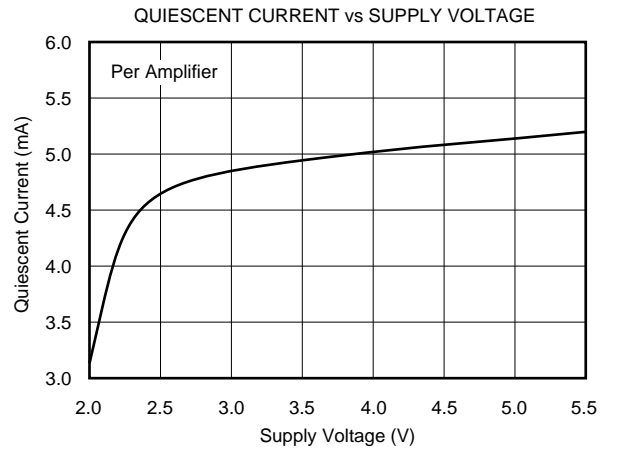
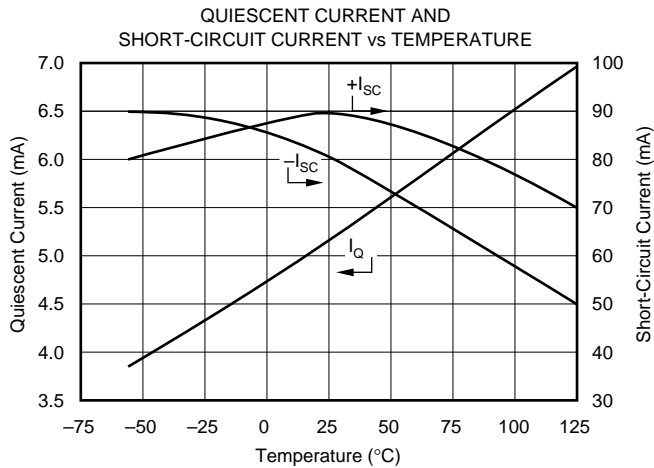
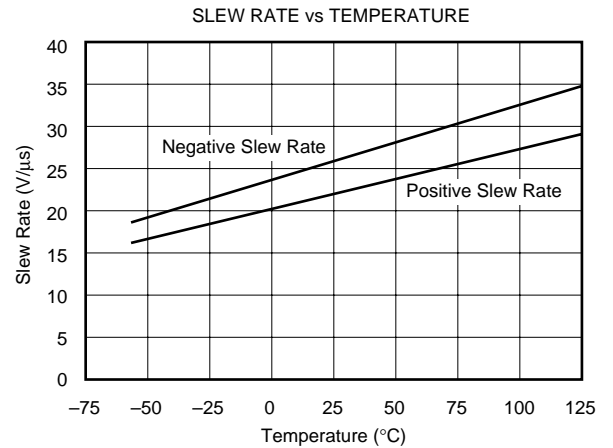
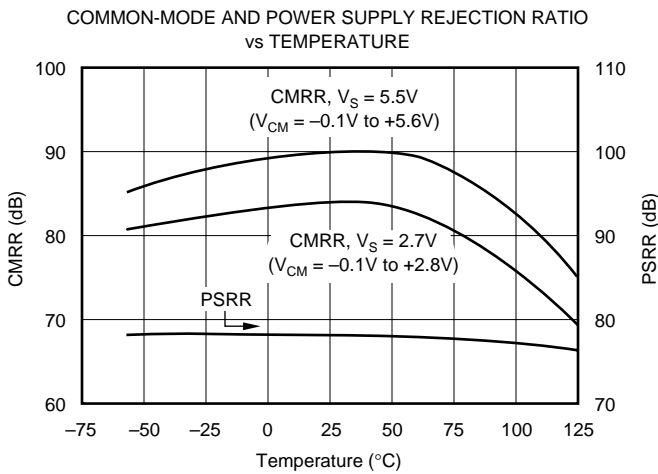
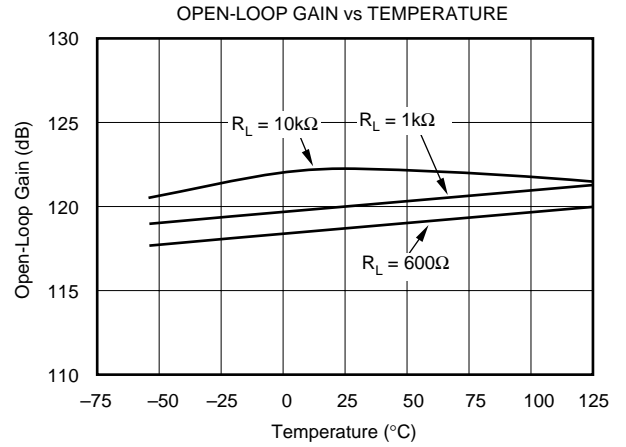
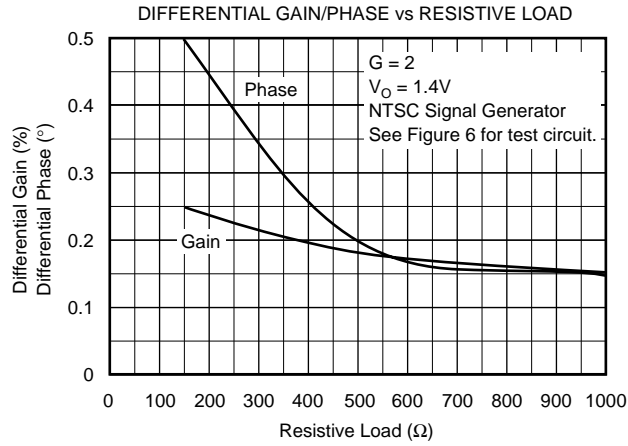

# TYPICAL PERFORMANCE CURVES (CONT)

At  $T_A = +25^\circ\text{C}$ ,  $V_S = +5\text{V}$ , and  $R_L = 1\text{k}\Omega$  connected to  $V_S/2$ , unless otherwise noted.

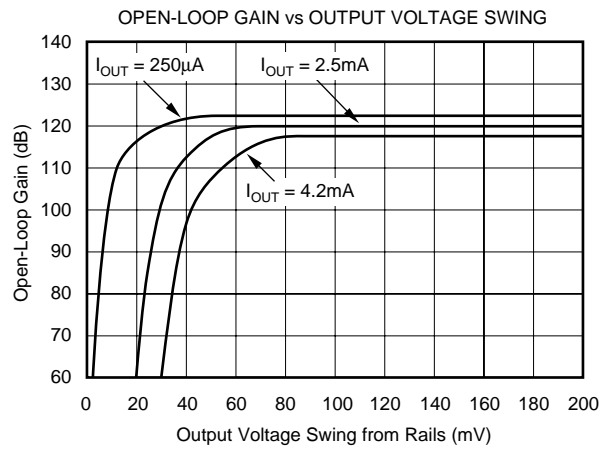
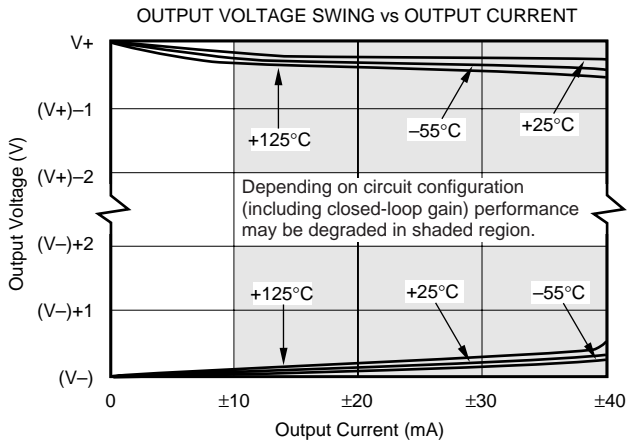
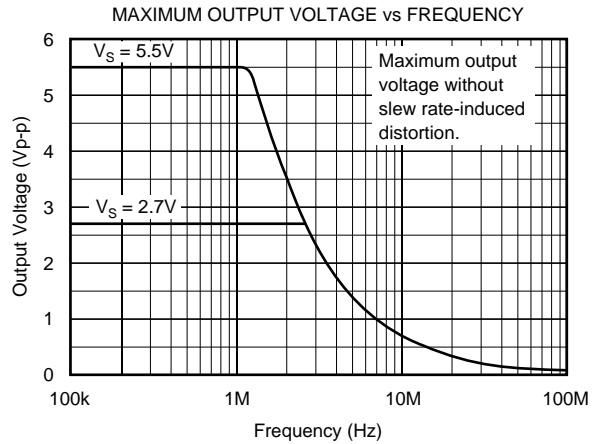
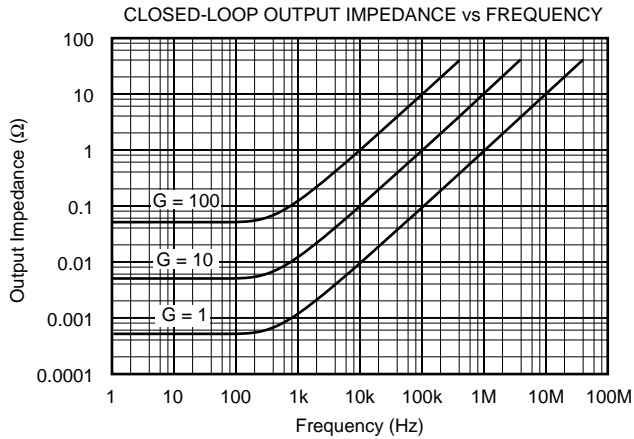
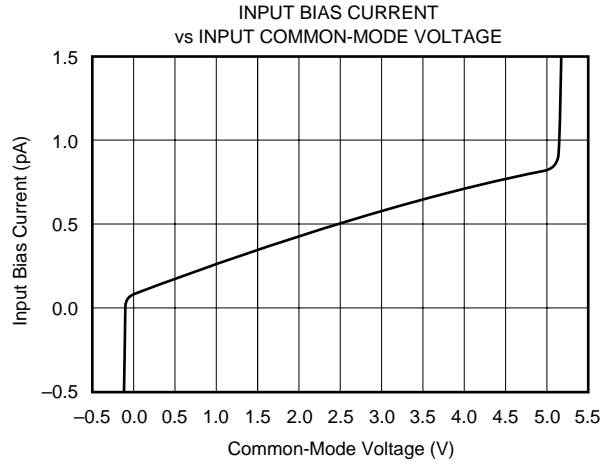
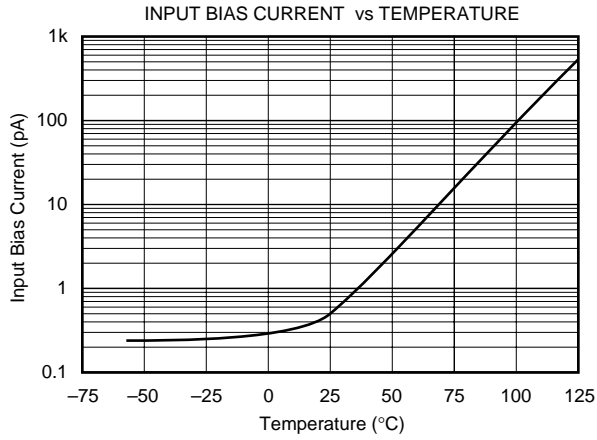

# TYPICAL PERFORMANCE CURVES (CONT)

At  $T_A = +25^\circ\text{C}$ ,  $V_S = +5\text{V}$ , and  $R_L = 1\text{k}\Omega$  connected to  $V_S/2$ , unless otherwise noted.

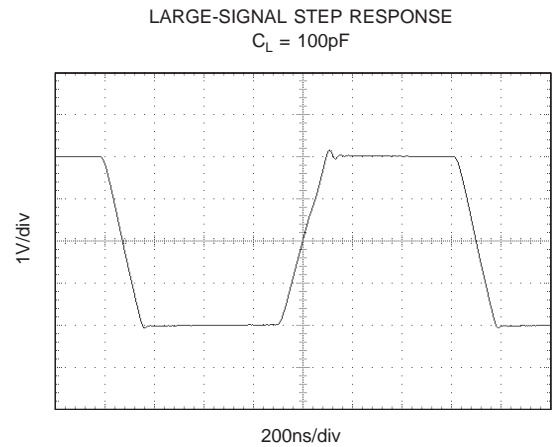
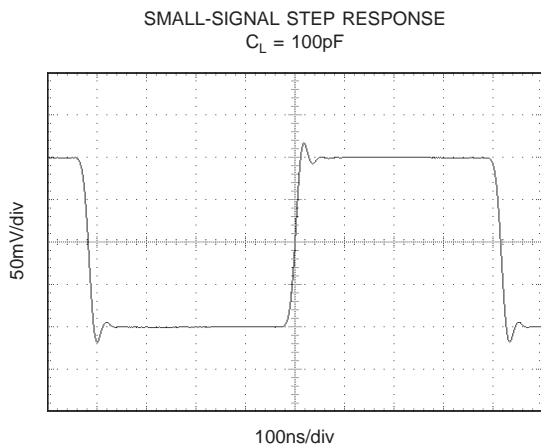
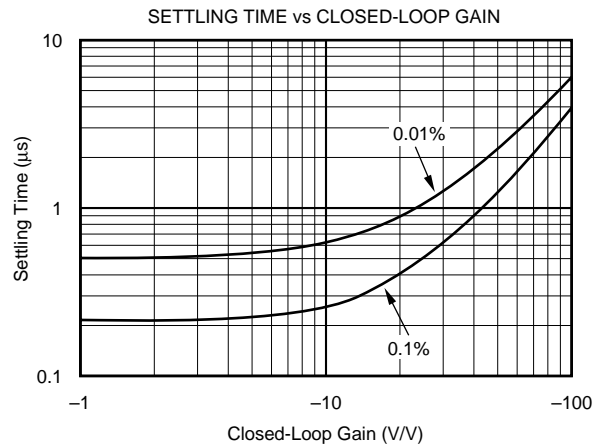
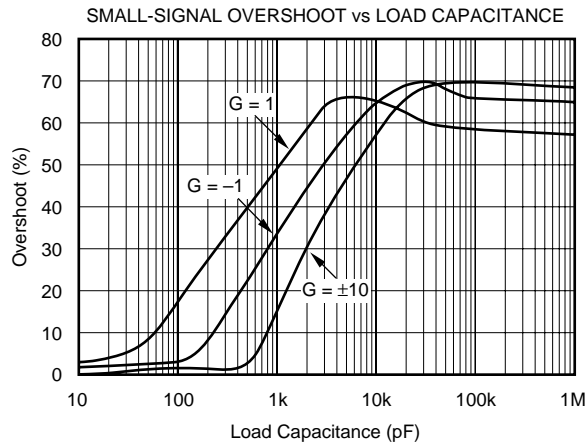
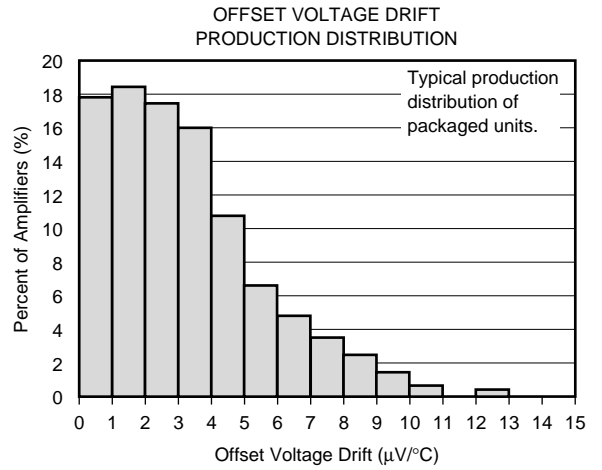
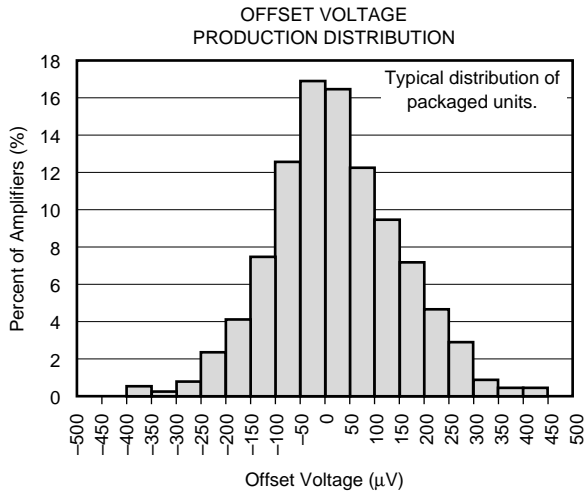

# APPLICATIONS INFORMATION

OPA350 series op amps are fabricated on a state-of-the-art 0.6 micron CMOS process. They are unity-gain stable and suitable for a wide range of general purpose applications. Rail-to-rail input/output make them ideal for driving sampling A/D converters. They are also well suited for controlling the output power in cell phones. These applications often require high speed and low noise. In addition, the OPA350 series offers a low cost solution for general purpose and consumer video applications (75Ω drive capability).

Excellent ac performance makes the OPA350 series well suited for audio applications. Their bandwidth, slew rate, low noise (5nV/√Hz), low THD (0.0006%), and small package options are ideal for these applications. The class AB output stage is capable of driving 600Ω loads connected to any point between V+ and ground.

Rail-to-rail input and output swing significantly increases dynamic range, especially in low voltage supply applications. Figure 1 shows the input and output waveforms for

the OPA350 in unity-gain configuration. Operation is from a single +5V supply with a 1kΩ load connected to V<sub>S</sub>/2. The input is a 5Vp-p sinusoid. Output voltage swing is approximately 4.95Vp-p.

Power supply pins should be bypassed with 0.01μF ceramic capacitors.

## OPERATING VOLTAGE

OPA350 series op amps are fully specified from +2.7V to +5.5V. However, supply voltage may range from +2.5V to +5.5V. Parameters are guaranteed over the specified supply range—a unique feature of the OPA350 series. In addition, many specifications apply from -40°C to +85°C. Most behavior remains virtually unchanged throughout the full operating voltage range. Parameters which vary significantly with operating voltage or temperature are shown in the typical performance curves.

## RAIL-TO-RAIL INPUT

The guaranteed input common-mode voltage range of the OPA350 series extends 100mV beyond the supply rails. This is achieved with a complementary input stage—an N-channel input differential pair in parallel with a P-channel differential pair (see Figure 2). The N-channel pair is active for input voltages close to the positive rail, typically (V+) - 1.8V to 100mV above the positive supply, while the P-channel pair is on for inputs from 100mV below the negative supply to approximately (V+) - 1.8V. There is a small transition region, typically (V+) - 2V to (V+) - 1.6V, in which both pairs are on. This 400mV transition region can vary ±400mV with process variation. Thus, the transition region (both input stages on) can range from (V+) - 2.4V to (V+) - 2.0V on the low end, up to (V+) - 1.6V to (V+) - 1.2V on the high end.

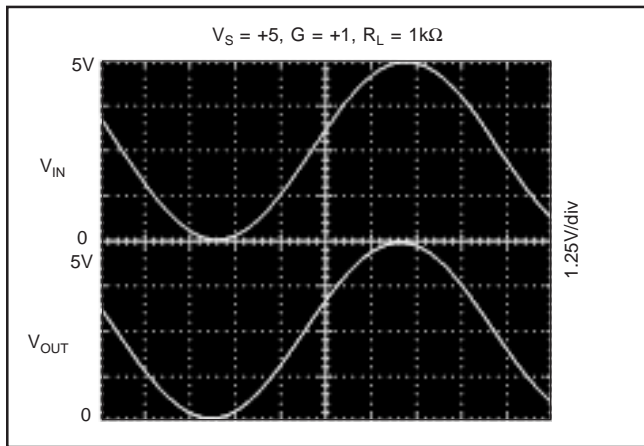
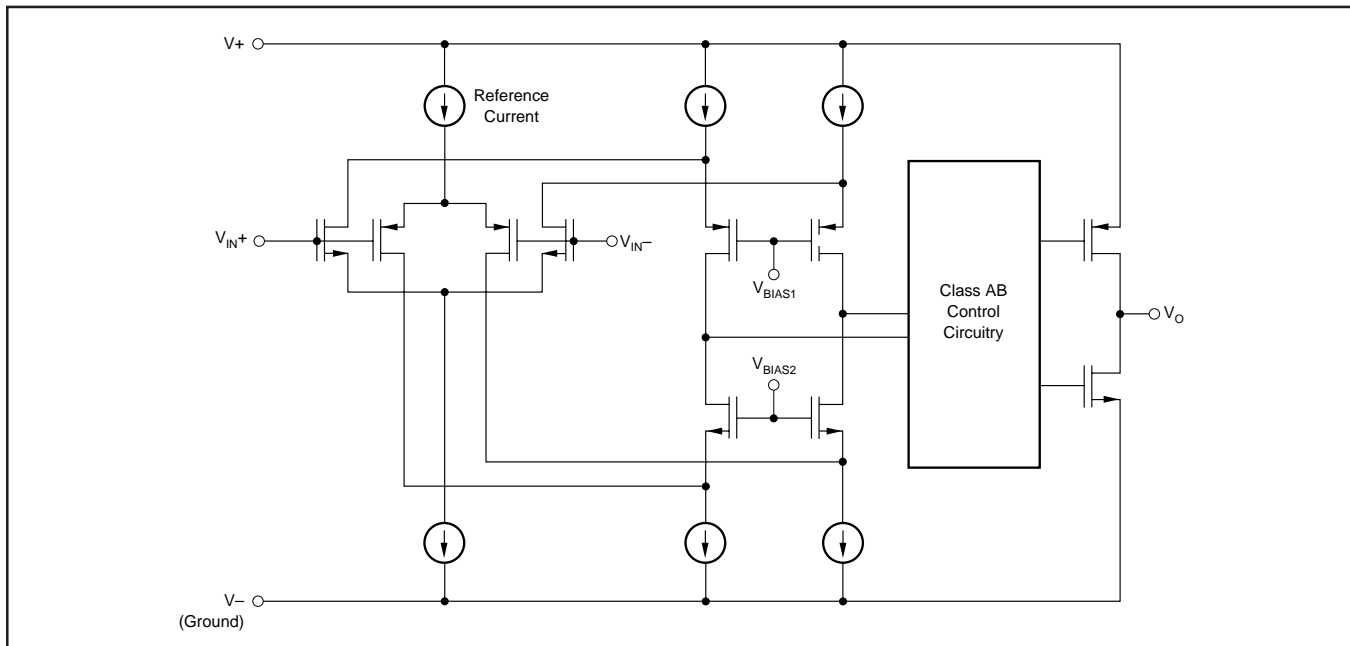

FIGURE 1. Rail-to-Rail Input and Output.





OPA350 series op amps are laser-trimmed to reduce offset voltage difference between the N-channel and P-channel input stages, resulting in improved common-mode rejection and a smooth transition between the N-channel pair and the P-channel pair. However, within the 400mV transition region PSRR, CMRR, offset voltage, offset drift, and THD may be degraded compared to operation outside this region.

A double-folded cascode adds the signal from the two input pairs and presents a differential signal to the class AB output stage. Normally, input bias current is approximately 500fA. However, large inputs (greater than 300mV beyond the supply rails) can turn on the OPA350's input protection diodes, causing excessive current to flow in or out of the input pins. Momentary voltages greater than 300mV beyond the power supply can be tolerated if the current on the input pins is limited to 10mA. This is easily accomplished with an input resistor as shown in Figure 3. Many input signals are inherently current-limited to less than 10mA, therefore, a limiting resistor is not required.

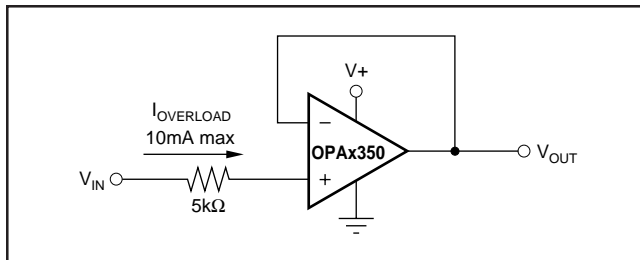

FIGURE 3. Input Current Protection for Voltages Exceeding the Supply Voltage.

### RAIL-TO-RAIL OUTPUT

A class AB output stage with common-source transistors is used to achieve rail-to-rail output. For light resistive loads (>10kΩ), the output voltage swing is typically a ten millivolts from the supply rails. With heavier resistive loads (600Ω to 10kΩ), the output can swing to within a few tens of millivolts from the supply rails and maintain high open-loop gain. See the typical performance curves “Output Voltage Swing vs Output Current” and “Open-Loop Gain vs Output Voltage.”

### CAPACITIVE LOAD AND STABILITY

OPA350 series op amps can drive a wide range of capacitive loads. However, all op amps under certain conditions may become unstable. Op amp configuration, gain, and load value are just a few of the factors to consider when determining stability. An op amp in unity gain configuration is the most susceptible to the effects of capacitive load. The capacitive load reacts with the op amp's output impedance, along with any additional load resistance, to create a pole in the small-signal response which degrades the phase margin.

In unity gain, OPA350 series op amps perform well with very large capacitive loads. Increasing gain enhances the amplifier's ability to drive more capacitance. The typical

performance curve “Small-Signal Overshoot vs Capacitive Load” shows performance with a 1kΩ resistive load. Increasing load resistance improves capacitive load drive capability.

### FEEDBACK CAPACITOR IMPROVES RESPONSE

For optimum settling time and stability with high-impedance feedback networks, it may be necessary to add a feedback capacitor across the feedback resistor,  $R_F$ , as shown in Figure 4. This capacitor compensates for the zero created by the feedback network impedance and the OPA350's input capacitance (and any parasitic layout capacitance). The effect becomes more significant with higher impedance networks.

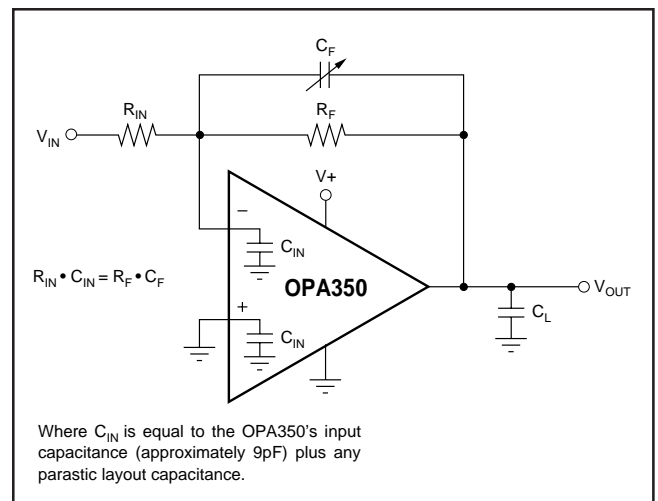

FIGURE 4. Feedback Capacitor Improves Dynamic Performance.

It is suggested that a variable capacitor be used for the feedback capacitor since input capacitance may vary between op amps and layout capacitance is difficult to determine. For the circuit shown in Figure 4, the value of the variable feedback capacitor should be chosen so that the input resistance times the input capacitance of the OPA350 (typically 9pF) plus the estimated parasitic layout capacitance equals the feedback capacitor times the feedback resistor:

$$R_{IN} \cdot C_{IN} = R_F \cdot C_F$$

where  $C_{IN}$  is equal to the OPA350's input capacitance (sum of differential and common-mode) plus the layout capacitance. The capacitor can be varied until optimum performance is obtained.

### DRIVING A/D CONVERTERS

OPA350 series op amps are optimized for driving medium speed (up to 500kHz) sampling A/D converters. However, they also offer excellent performance for higher speed converters. The OPA350 series provides an effective means of buffering the A/D's input capacitance and resulting charge injection while providing signal gain.



Figure 5 shows the OPA350 driving an ADS7861. The ADS7861 is a dual, 500kHz 12-bit sampling converter in the tiny SSOP-24 package. When used with the miniature package options of the OPA350 series, the combination is ideal for space-limited applications. For further information, consult the ADS7861 data sheet.

### OUTPUT IMPEDANCE

The low frequency open-loop output impedance of the OPA350's common-source output stage is approximately 1kΩ. When the op amp is connected with feedback, this value is reduced significantly by the loop gain of the op amp. For example, with 122dB of open-loop gain, the output impedance is reduced in unity-gain to less than 0.001Ω. For each decade rise in the closed-loop gain, the loop gain is reduced by the same amount which results in a ten-fold increase in effective output impedance (see the typical performance curve, "Output Impedance vs Frequency").

At higher frequencies, the output impedance will rise as the open-loop gain of the op amp drops. However, at these frequencies the output also becomes capacitive due to parasitic capacitance. This prevents the output impedance

from becoming too high, which can cause stability problems when driving capacitive loads. As mentioned previously, the OPA350 has excellent capacitive load drive capability for an op amp with its bandwidth.

### VIDEO LINE DRIVER

Figure 6 shows a circuit for a single supply,  $G = 2$  composite video line driver. The synchronized outputs of a composite video line driver extend below ground. As shown, the input to the op amp should be ac-coupled and shifted positively to provide adequate signal swing to account for these negative signals in a single-supply configuration.

The input is terminated with a 75Ω resistor and ac-coupled with a 47μF capacitor to a voltage divider that provides the dc bias point to the input. In Figure 6, this point is approximately  $(V-) + 1.7V$ . Setting the optimal bias point requires some understanding of the nature of composite video signals. For best performance, one should be careful to avoid the distortion caused by the transition region of the OPA350's complementary input stage. Refer to the discussion of rail-to-rail input.

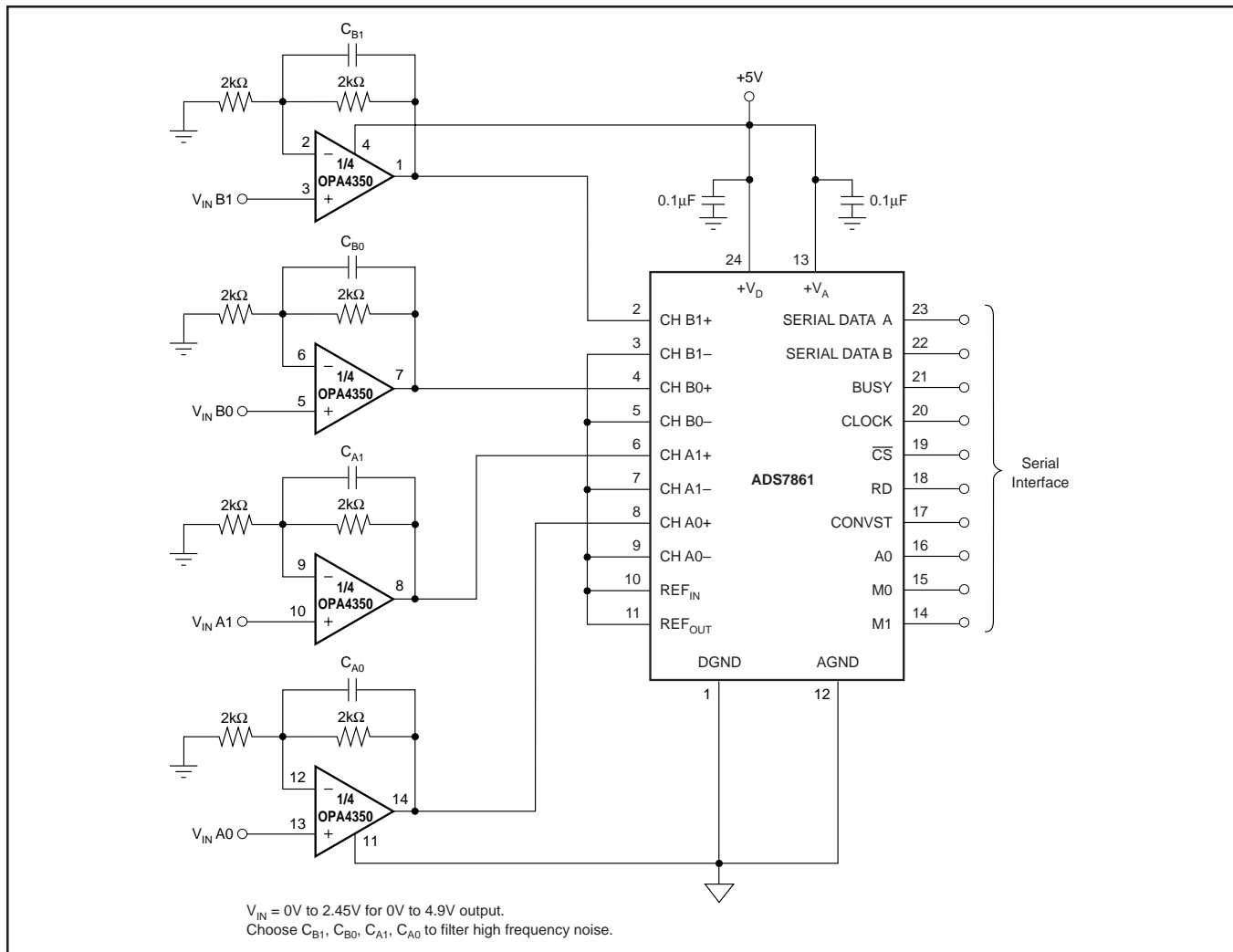

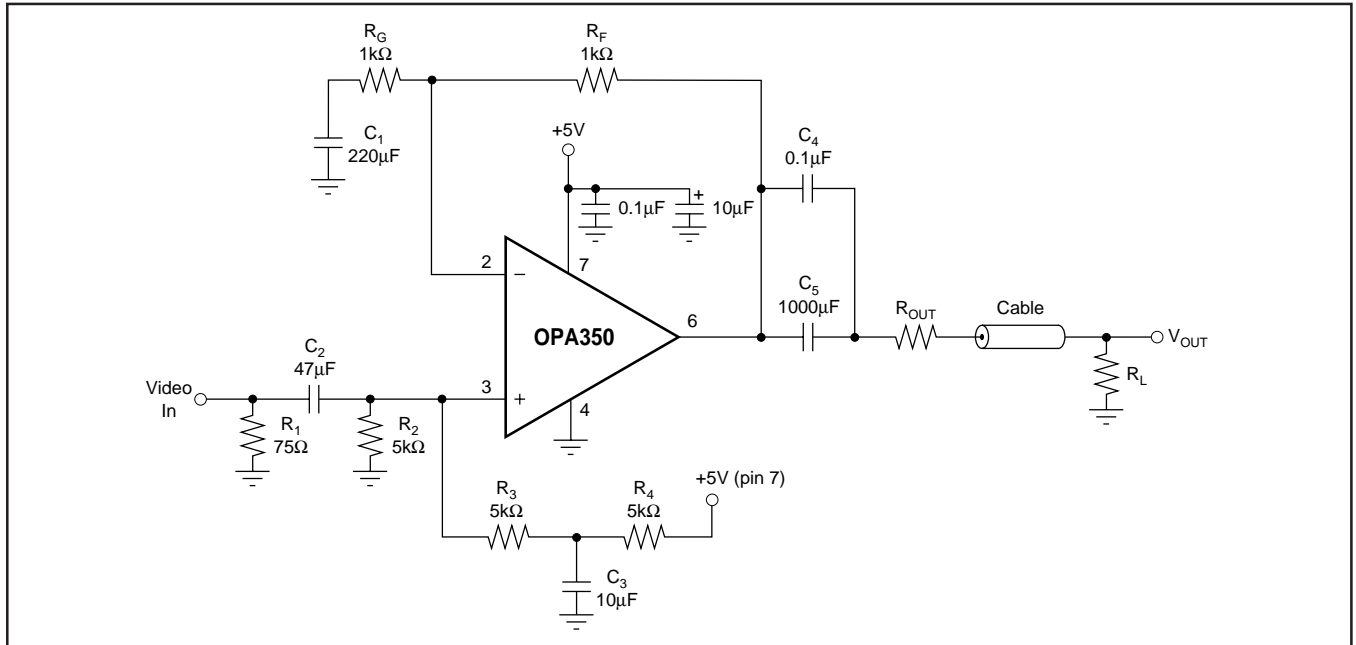

FIGURE 6. Single-Supply Video Line Driver.

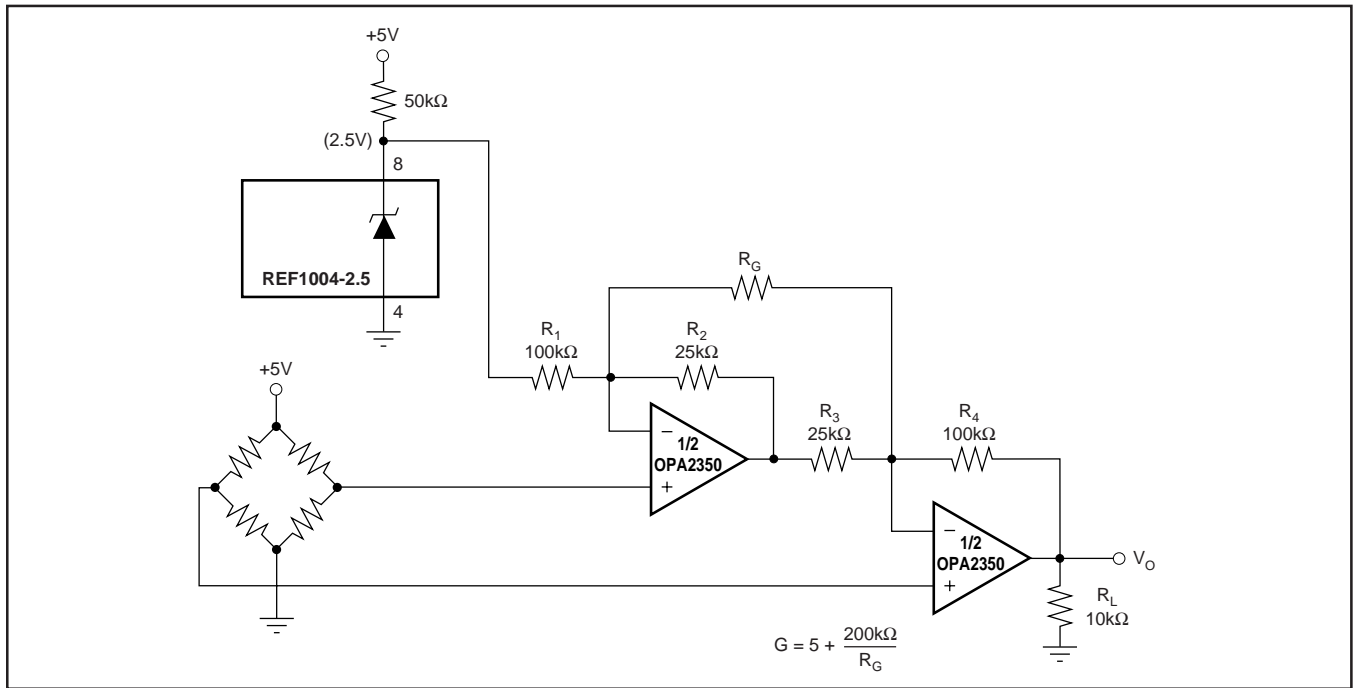

FIGURE 7. Two Op-Amp Instrumentation Amplifier With Improved High Frequency Common-Mode Rejection.

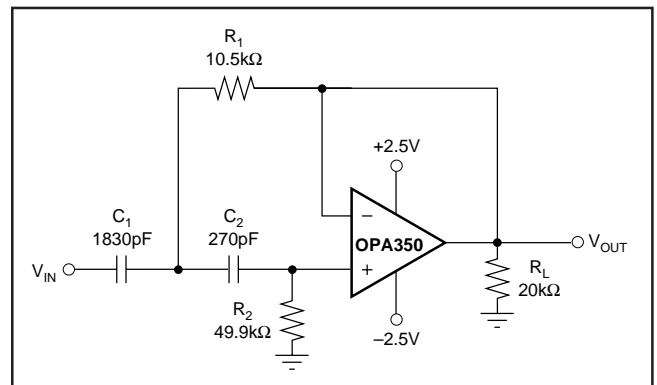
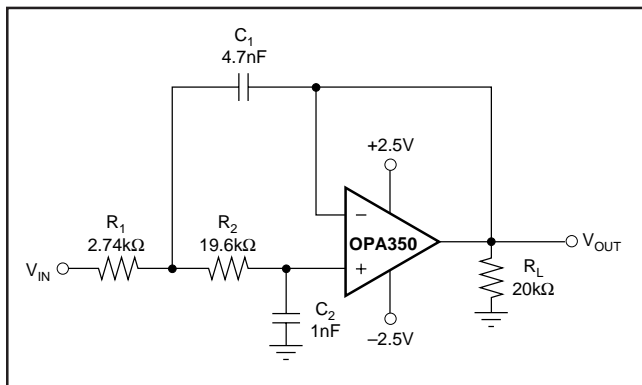

FIGURE 9. 10kHz High-Pass Filter.



## IMPORTANT NOTICE

Texas Instruments and its subsidiaries (TI) reserve the right to make changes to their products or to discontinue any product or service without notice, and advise customers to obtain the latest version of relevant information to verify, before placing orders, that information being relied on is current and complete. All products are sold subject to the terms and conditions of sale supplied at the time of order acknowledgment, including those pertaining to warranty, patent infringement, and limitation of liability.

TI warrants performance of its semiconductor products to the specifications applicable at the time of sale in accordance with TI's standard warranty. Testing and other quality control techniques are utilized to the extent TI deems necessary to support this warranty. Specific testing of all parameters of each device is not necessarily performed, except those mandated by government requirements.

Customers are responsible for their applications using TI components.

In order to minimize risks associated with the customer's applications, adequate design and operating safeguards must be provided by the customer to minimize inherent or procedural hazards.

TI assumes no liability for applications assistance or customer product design. TI does not warrant or represent that any license, either express or implied, is granted under any patent right, copyright, mask work right, or other intellectual property right of TI covering or relating to any combination, machine, or process in which such semiconductor products or services might be or are used. TI's publication of information regarding any third party's products or services does not constitute TI's approval, warranty or endorsement thereof.

Copyright © 2000, Texas Instruments Incorporated

