

To all our customers

---

## **Regarding the change of names mentioned in the document, such as Mitsubishi Electric and Mitsubishi XX, to Renesas Technology Corp.**

---

The semiconductor operations of Hitachi and Mitsubishi Electric were transferred to Renesas Technology Corporation on April 1st 2003. These operations include microcomputer, logic, analog and discrete devices, and memory chips other than DRAMs (flash memory, SRAMs etc.) Accordingly, although Mitsubishi Electric, Mitsubishi Electric Corporation, Mitsubishi Semiconductors, and other Mitsubishi brand names are mentioned in the document, these names have in fact all been changed to Renesas Technology Corp. Thank you for your understanding. Except for our corporate trademark, logo and corporate statement, no changes whatsoever have been made to the contents of the document, and these changes do not constitute any alteration to the contents of the document itself.

Note : Mitsubishi Electric will continue the business operations of high frequency & optical devices and power devices.

Renesas Technology Corp.  
Customer Support Dept.  
April 1, 2003



mitsubishi  
**MITSUBISHI INSULATED GATE BIPOLAR TRANSISTOR**

# CT60AM-18B

**RESONANT INVERTER USE**

## CT60AM-18B



- VCES ..... 900V
- IC ..... 60A
- Integrated Fast Recovery Diode

## OUTLINE DRAWING

Dimensions in mm

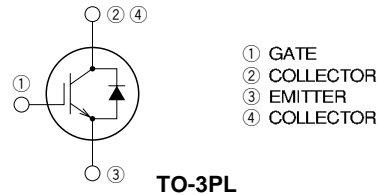
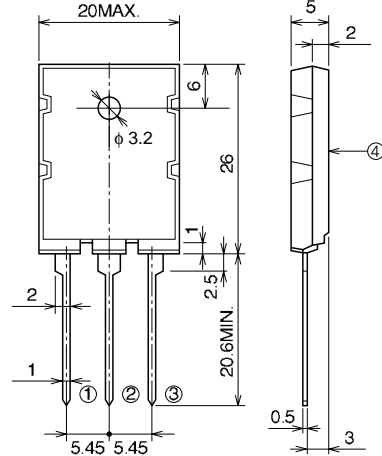

## APPLICATION

Microwave ovens, electromagnetic cooking devices, rice-cookers

### MAXIMUM RATINGS (Tc = 25°C)

Symbol	Parameter	Conditions	Ratings	Unit
V <sub>CE</sub> S	Collector-emitter voltage	V <sub>GE</sub> = 0V	900	V
V <sub>GE</sub> S	Gate-emitter voltage	V <sub>CE</sub> = 0V	±20	V
V <sub>GEM</sub>	Peak gate-emitter voltage	V <sub>CE</sub> = 0V	±30	V
I <sub>C</sub>	Collector current		60	A
I <sub>CM</sub>	Collector current (Pulsed)		120	A
I <sub>E</sub>	Emitter current		40	A
P <sub>C</sub>	Maximum power dissipation	T <sub>c</sub> = 25°C	200	W
T <sub>j</sub>	Junction temperature		-40 ~ +150	°C
T <sub>stg</sub>	Storage temperature		-40 ~ +150	°C



**ELECTRICAL CHARACTERISTICS** (T<sub>j</sub> = 25°C unless otherwise noted)

Symbol	Parameter	Test conditions	Limits			Unit
			Min.	Typ.	Max.	
V(BR)CES	Collector-emitter breakdown voltage	I <sub>c</sub> = 1mA, V <sub>GE</sub> = 0V	900	—	—	V
I <sub>CES</sub>	Collector-emitter leakage current	V <sub>CE</sub> = 900V, V <sub>GE</sub> = 0V	—	—	1	mA
I <sub>GES</sub>	Gate-emitter leakage current	V <sub>GE</sub> = ±20V, V <sub>CE</sub> = 0V	—	—	±0.5	μA
V <sub>GE(th)</sub>	Gate-emitter threshold voltage	V <sub>CE</sub> = 10V, I <sub>c</sub> = 6mA	2.0	4.0	6.0	V
V <sub>CE(sat)</sub>	Collector-emitter saturation voltage	I <sub>c</sub> = 60A, V <sub>CE</sub> = 15V	—	2.0	2.7	V
C <sub>ies</sub>	Input capacitance	V <sub>CE</sub> = 25V, V <sub>GE</sub> = 0V, f = 1MHz	—	5000	—	pF
C <sub>oes</sub>	Output capacitance		—	125	—	pF
C <sub>res</sub>	Reverse transfer capacitance		—	85	—	pF
t <sub>d(on)</sub>	Turn-on delay time	I <sub>c</sub> = 60A, Resistance load, V <sub>CC</sub> = 300V, V <sub>GE</sub> = 15V, R <sub>G</sub> = 10Ω	—	0.05	—	μs
t <sub>r</sub>	Rise time		—	0.12	—	μs
t <sub>d(off)</sub>	Turn-off delay time		—	0.30	—	μs
t <sub>f</sub>	Fall time		—	0.25	—	μs
E <sub>tail</sub>	Tail loss	I <sub>CP</sub> = 60A, T <sub>j</sub> = 125°C,	—	0.6	1.0	mJ/pls
I <sub>Ctail</sub>	Collector tail current	dv/dt = 200V/μs	—	6	12	A
V <sub>EC</sub>	Emitter-collector voltage	I <sub>E</sub> = 60A, V <sub>GE</sub> = 0V	—	—	3	V
T <sub>rr</sub>	Reverse recovery time	I <sub>E</sub> = 60A, di/dt = 20A/μs	—	0.5	2	μs
R <sub>th(j-c)</sub>	Thermal resistance (IGBT part)	Junction to case	—	—	0.63	°C/W
R <sub>th(j-c)</sub>	Thermal resistance	Junction to case	—	—	4.0	°C/W

**PERFORMANCE CURVES**

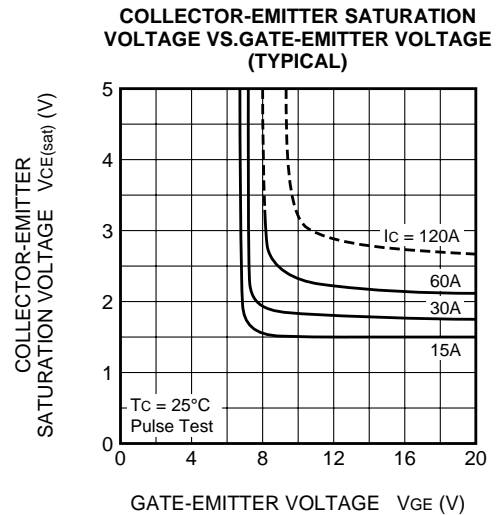
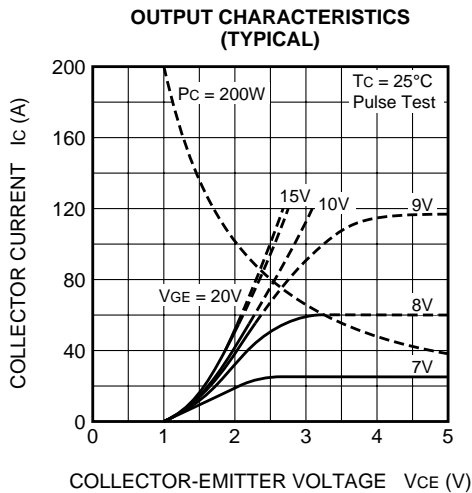

# CT60AM-18B

## RESONANT INVERTER USE

**COLLECTOR CURRENT VS. GATE-EMITTER VOLTAGE (TYPICAL)**

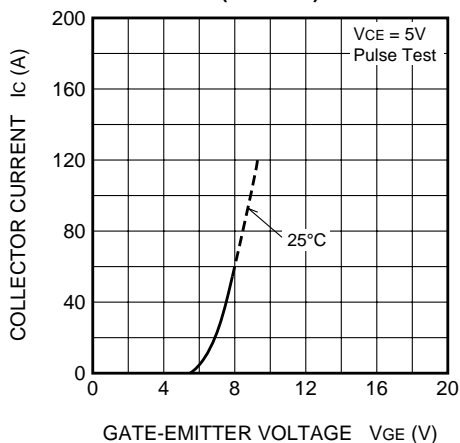

**CAPACITANCE VS. COLLECTOR-EMITTER VOLTAGE (TYPICAL)**

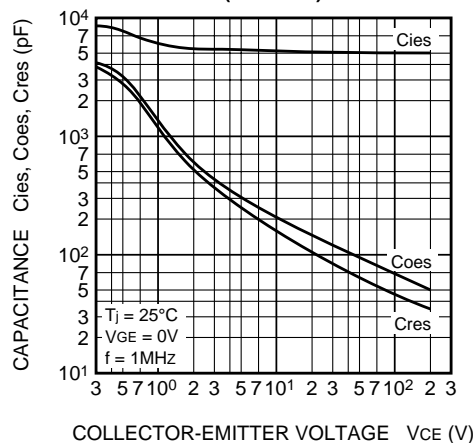

**SWITCHING CHARACTERISTICS (TYPICAL)**

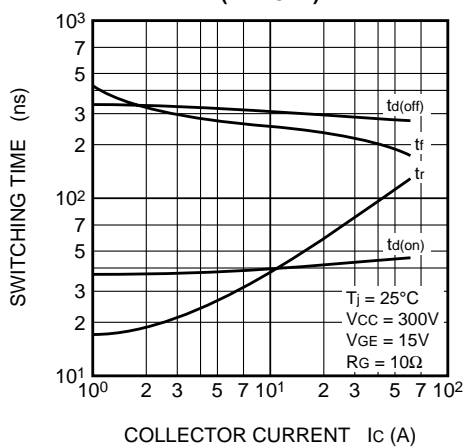

**SWITCHING TIME VS. GATE RESISTANCE (TYPICAL)**

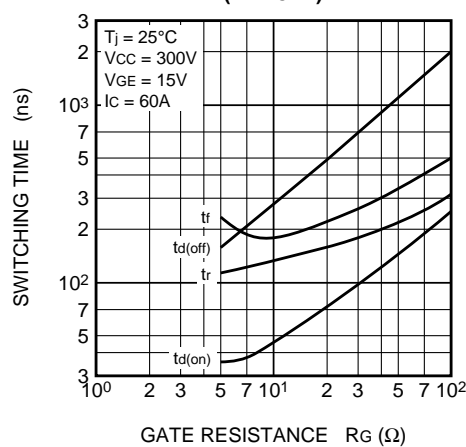

**GATE-EMITTER VOLTAGE VS. GATE CHARGE CHARACTERISTIC (TYPICAL)**

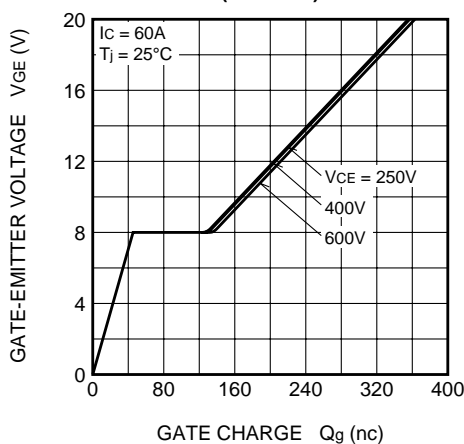

**TRANSFER CHARACTERISTICS (TYPICAL)**

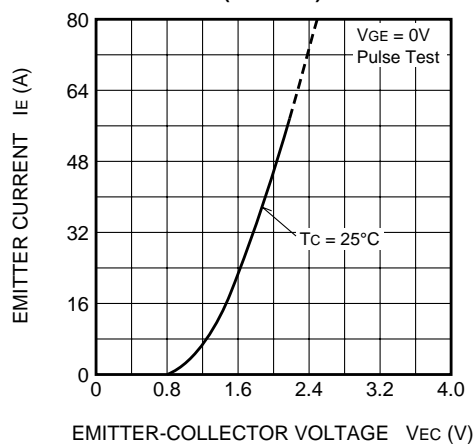

CT60AM-18B

RESONANT INVERTER USE

