

# LSI402ZX Digital Signal Processor

## ZSP Architecture Performance with High-End Integration

### Overview

The LSI402ZX is a high-performance 16-bit fixed-point digital signal processor (DSP) based on the ZSP™ Architecture. This device has been designed for applications that require high data throughput capability coupled with high-speed I/O, such as communications infrastructure equipment, and offers enhanced I/O capabilities and large on-chip memory. The LSI402ZX is capable of a maximum clock rate of 200 MHz for 800 MIPS peak performance and sustained effective throughput of 400 MMACs.

### Memory

The internal memory structure of the LSI402ZX comprises 62K words of data RAM, 62K words of instruction RAM, 2K words of boot ROM, and 2K words of data space dedicated to memory-mapped registers and external peripherals. The boot ROM contains several routines, including internal self-test, and boot-loader routines. The Memory Interface Unit (MIU) provides a glueless interface to industry-standard 32-bit synchronous-burst SRAMs (SBSRAMs), and 16-bit asynchronous SRAMs and ROM devices. The total address range of the MIU is 20 bits, organized as sixteen 64K word pages which are selected by a software-controlled page register.

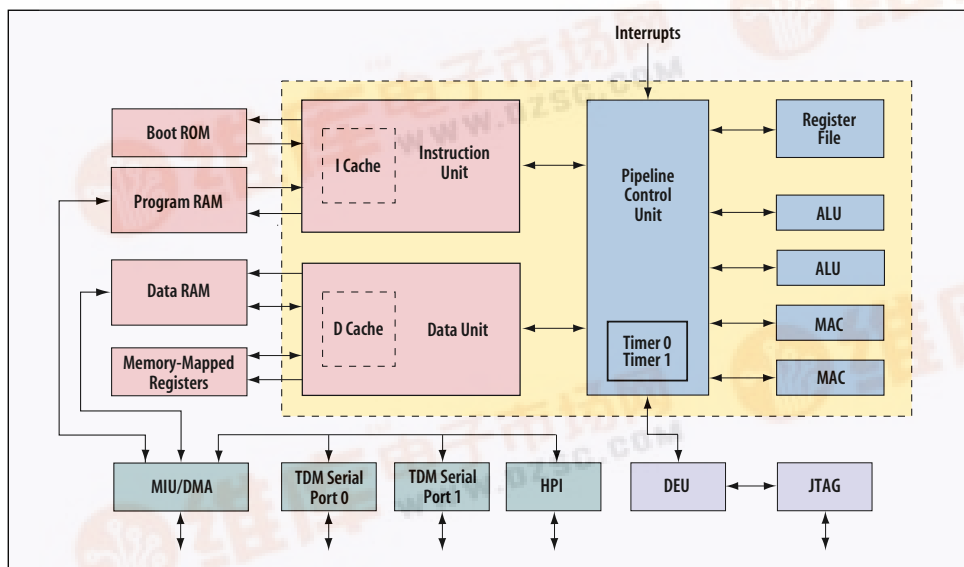

Functional Block Diagram

### Features

- 200 MHz operation at 1.8 V (5 ns cycle time)
- Two high-speed serial/TDM ports (T1/E1 framer, H.100/H.110 bit stream compatible)
- Low power dissipation (800 mW at 200 MHz)
- 62K words data RAM
- 62K words instruction RAM
- 2K words ROM
- Eight-channel DMA support
- On-board PLL for clock generation
- 32-/16-bit external memory interface
- Two on-board timers
- 16-bit host processor interface
- IEEE 1149.1-compliant JTAG port for real-time emulation and system download

### Benefits

- 400 MMAC sustained DSP performance at 200 MHz
- Direct interfacing to standard telecommunication interfaces, reducing system cost
- Low power per channel
- Low or zero system memory cost
- High data throughput without processor overhead
- Flexibility to optimize power consumption
- High data bandwidth to off-chip devices
- RTOS support and increased system integration
- Simple interfacing to industry-standard micros
- Low overhead on chip debug
- Very high processing density per unit area



# LSI402ZX Digital Signal Processor

## DMA

The DMA controller of the LSI402ZX can support up to eight individual channels, where all channels can access the entire 64K word data RAM and 64K word instruction RAM. Either instructions or data can be transferred to or from the internal memory space from the MIU, HPI, or either serial port. The eight DMA channels are segmented into four "indexed" and four "non-indexed" channels. Indexed channels have the ability to interleave data from either of the serial TDM interfaces. Non-indexed channels perform sequential accesses to or from internal memory.

## Timers

The LSI402ZX has two identical 16-bit on-board timers for real-time interrupt generation. Each timer is fully programmable, and has a 6-bit pre-scaler and interrupt capability. The timers can automatically reload with the initial count so that periodic interrupts can be generated.

## TDM Serial Ports

The LSI402ZX provides two identical synchronous serial ports that support 8- or 16-bit active or passive transfers, which can be either burst or continuous, with a maximum active mode transfer rate of 100 Mbps (with a 200 MHz processor clock). In passive mode, the maximum transfer rate is 200 Mbps. Both serial ports provide the programmable feature of a TDM (time division multiplex) mode that is compatible with T1/E1 framers or the local serial bus of H.100/ H.110 interface devices. The TDM mode can also be used to establish a serial multiprocessor communication link with only three signals.

## Host Processor Interface (HPI)

The Host Processor Interface, or HPI, is an asynchronous 16-bit parallel port that is compatible with both Motorola and Intel style interfaces, and supports word (16-bit) and byte (8-bit) transfers. The maximum transfer rate for the HPI is half of the processor clock frequency (100M words per second given a processor operating frequency of 200 MHz).

## Development Tools

The ZSP Processor family is fully supported by a GNU-based compiler, linker and assembler, available for Windows 95/98/NT and Solaris 2 platforms. The ZSP Architecture enables the C compiler to produce code unrivaled in code density and execution speed by any DSP in its class, offering fast time to market with optimal performance and cost. An integrated debug environment is available for PC platforms.

An LSI402ZX development platform is available, offering the following features:

- FLASH EPROM
- RS232C and JTAG-based host communication and code download
- 512K words SBSRAM expansion program/data memory
- 64K words asynchronous program/data memory



For more information please call:

LSI Logic Corporation  
North American Headquarters  
Milpitas, CA  
Tel: 800.574.4286

LSI Logic Europe Ltd  
European Headquarters  
United Kingdom  
Tel: 44.1344.426544  
Fax: 44.1344.481039

LSI Logic KK Headquarters  
Tokyo, Japan  
Tel: 81.3.5463.7165  
Fax: 81.3.5463.7820

LSI Logic web site:  
[www.lsillogic.com](http://www.lsillogic.com)

ISO 9000 Certified

LSI Logic logo design is a registered trademark and ZSP is a trademark of LSI Logic Corporation. All other brand and product names may be trademarks of their respective companies.

LSI Logic Corporation reserves the right to make changes to any products and services herein at any time without notice. LSI Logic does not assume any responsibility or liability arising out of the application or use of any product or service described herein, except as expressly agreed to in writing by LSI Logic; nor does the purchase, lease, or use of a product or service from LSI Logic convey a license under any patent rights, copyrights, trademark rights, or any other of the intellectual property rights of LSI Logic or of third parties.

Copyright ©2000 by LSI Logic Corporation.  
All rights reserved.

LSI LOGIC®

Order No. R20025  
700.25K.ML.TP - Printed in USA