

3859

FM COMMUNICATIONS IF SYSTEM

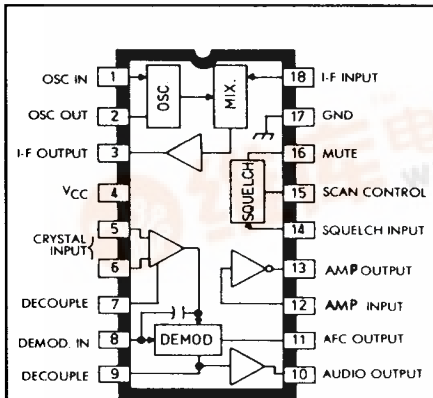

This low-power, narrow-band FM IF system provides the second converter, second IF, demodulator, and squelch circuitry for communications and scanning receivers.

The ULN3859A's double-balanced mixer permits low-noise operation while eliminating spurious responses, effectively rejecting tweet and IF feedthrough, and reducing local oscillator radiation. The mixer's high input impedance matches popular 10.7 MHz crystal filters while its output impedance matches most 455 kHz ceramic filters. Although designed for use with a 10.7 MHz first IF and a 455 kHz second IF, the mixer operates at other RF or IF input frequencies through 30 MHz.

A multi-stage 1 MHz differential amplifier/limiter following the second IF filter operates as a high gain stage with excellent common-mode rejection.

Audio is recovered by a quadrature FM detector that requires only a single low-cost tuned circuit.

The ULN3859A has both a low-impedance emitter-follower audio output and an AFC output. Few external components are needed for operation with noise-activated or tone squelch.

This communications IF system meets the stability requirements of many automotive applications, and also meets the low-power demands of portable radio design. Internal voltage regulators and bias supplies ensure stable performance despite variations in external supply voltage (4 to 9 V) or temperature (-30°C to +70°C).

FEATURES

- Dual Conversion
- Low Current Drain
- Wide Operating Voltage Range
- High Sensitivity
- Replaces MC3359P

ABSOLUTE MAXIMUM RATINGS

Supply Voltage, V_{CC}	12 V
Mixer Input Voltage, V_{in}	1.0 V
Mute Terminal Voltage Range, V_{16}	-0.5 V to +12 V
Operating Temperature Range, T_A	-30°C to +70°C
Storage Temperature Range,	-65°C to +150°C

Always order by complete part number: **ULN3859A**

3859

FM COMMUNICATIONS IF SYSTEM

ELECTRICAL CHARACTERISTICS at $T_A = +25^\circ\text{C}$, $V_{CC} = 8.0\text{ V}$, $f_o = 10.7\text{ MHz}$, $f_m = 1.0\text{ kHz}$, $f_d = \pm 3.0\text{ kHz}$ (unless otherwise noted).

Characteristic	Test Pin	Test Conditions	Limits			Units
			Min.	Typ.	Max.	
Operating Voltage Range	4		4.0	8.0	9.0	V
Quiescent Supply Current	4	$V_{14} = 0$, Mute OFF	—	3.0	6.0	mA
		$V_{14} \geq 0.7\text{ V}$, Mute ON	—	4.0	7.0	mA
Input Limiting Threshold	18	-3 dB Limiting	—	2.0	6.0	μV
Mixer Conversion Gain	3	See Note 1, Below	—	24	—	dB
Mixer Input Resistance	18		—	3.6	—	$\text{k}\Omega$
Mixer Input Capacitance	18	See Note 2, Below	—	2.2	—	pF
Mixer Output Impedance	3		—	1.8	—	$\text{k}\Omega$
Limiter Input Impedance	5		—	1.8	—	$\text{k}\Omega$
Quiescent DC Output Voltage	10	$V_{in} = 0$	2.4	3.6	4.4	V
Audio Output Impedance	10		—	500	—	Ω
Recovered Audio Output	10	$V_{in} = 3.0\text{ mV}$	450	700	—	mV_{rms}
Amplifier Gain	13	$f = 4.0\text{ kHz}$, $V_{in} = 5.0\text{ mV}$	40	53	—	dB
Quiescent DC Output Voltage	13	$V_{in} = 0$	—	1.7	—	V
Mute Switch Resistance	16	$I_{16} = 2.5\text{ mA}$, $V_{14} \geq 0.7\text{ V}$	—	4.0	10	Ω
Scan Source Current	15	$V_{14} = V_{15} = 0$, Mute OFF	2.0	4.0	—	mA

APPLICATION INFORMATION

- In a typical application, with a 3.6 $\text{k}\Omega$ crystal filter source, the ULN3859A will give 23 dB conversion gain.
- Because crystal filters are extremely sensitive to reactive loading, radio designers frequently have added a coil and/or capacitor at pin 18 to cancel the input reactance component. This practice is not required with ULN3859A, since its input is designed to match typical 10.7 MHz crystal filters. However, if an external reactive component is used, it is important to adjust it for optimal passband shape and not simply peak it for maximum sensitivity.
- Pin 11 provides AFC. If AFC is not required, pin 11 should be grounded, or tied to pin 9 to double the available recovered audio.
- Pin 10 may require an external resistor (2 $\text{k}\Omega$ minimum) to ground to prevent audio rectification with some capacitive loads.

TEST CIRCUIT

