

NEC

MOS INTEGRATED CIRCUIT
 μ PD22100, 22148

CROSSPOINT SWITCH WITH CONTROL MEMORY
 CMOS IC

The μ PD22100 consists of 16 crosspoint switches organized in 4 rows and 4 columns, and the μ PD22148 consists of 32 crosspoint switches organized in 4 row and 8 columns. Any of the 16 or 32 switches can be selected by applying appropriate address. The selected crosspoint turns on if during strobe and data In are high and turns off if during strobe and data In are low.

FEATURES

μ PD22100

- 4 x 4 CROSSPOINT SWITCHES
- INTERNAL POWER ON RESET FUNCTION
- Low ON-RESISTANCE
60 Ω Typ. ($V_{DD} = 15 V$)
- Wide operating temperature Range
-40 $^{\circ}C$ to +85 $^{\circ}C$

μ PD22148

- 4 x 8 CROSSPOINT SWITCHES
- Including the Level Shifter Circuit
- Low ON-RESISTANCE
60 Ω Typ. ($V_{DD} = 15 V$)
- Wide operating temperature Range
-40 $^{\circ}C$ to +85 $^{\circ}C$

ORDERING INFORMATION

Part Number	Package
μ PD22100C	16 pin plastic DIP (300 mil)
μ PD22100GS	16 pin plastic SOP (300 mil)
μ PD22148CA	22 pin plastic shrink DIP (300 mil)

TRUTH TABLE

■ μ PD22100

INPUT						SELECTED CHANNELS																
S	D	C	B	A	DATA	Y ₀ X ₀	Y ₀ X ₁	Y ₀ X ₂	Y ₀ X ₃	Y ₁ X ₀	Y ₁ X ₁	Y ₁ X ₂	Y ₁ X ₃	Y ₂ X ₀	Y ₂ X ₁	Y ₂ X ₂	Y ₂ X ₃	Y ₃ X ₀	Y ₃ X ₁	Y ₃ X ₂	Y ₃ X ₃	
L	X	X	X	X	X	NC	→															
H	L	L	L	L	L	OFF	NC	→														
H	L	L	L	L	H	ON	NC	→														
H	L	L	L	H	L	NC	OFF	NC	→													
H	L	L	L	H	H	NC	ON	NC	→													
H	L	L	H	L	L	NC	→	OFF	NC	→												
H	L	L	H	L	H	NC	→	ON	NC	→												
H	L	L	H	H	L	NC	→	OFF	NC	→												
H	L	L	H	H	H	NC	→	ON	NC	→												
⋮	⋮	⋮	⋮	⋮	⋮	⋮	⋮															
H	H	H	H	H	L	NC	→															OFF
H	H	H	H	H	H	NC	→															ON



■ μPD22148

INPUTS						SELECTED CHANNELS																																
S	E	D	C	B	A	DATA	Y ₀	Y ₀	Y ₀	Y ₀	Y ₁	Y ₁	Y ₁	Y ₁	Y ₂	Y ₂	Y ₂	Y ₂	Y ₃	Y ₃	Y ₃	Y ₃	Y ₄	Y ₄	Y ₄	Y ₄	Y ₅	Y ₅	Y ₅	Y ₅	Y ₆	Y ₆	Y ₆	Y ₆	Y ₇	Y ₇	Y ₇	Y ₇
							X ₀	X ₁	X ₂	X ₃	X ₀	X ₁	X ₂	X ₃	X ₀	X ₁	X ₂	X ₃	X ₀	X ₁	X ₂	X ₃	X ₀	X ₁	X ₂	X ₃	X ₀	X ₁	X ₂	X ₃	X ₀	X ₁	X ₂	X ₃	X ₀	X ₁	X ₂	X ₃
L	X	X	X	X	X	X	NC	→																														
H	L	L	L	L	L	L	OFF NC	→																														
H	L	L	L	L	L	H	ON NC	→																														
H	L	L	L	L	H	L	NC OFF NC	→																														
H	L	L	L	L	H	H	NC ON NC	→																														
H	L	L	L	H	L	L	NC → OFF	→																														
H	L	L	L	H	L	H	NC → ON NC	→																														
H	L	L	L	H	H	L	NC → OFF NC	→																														
H	L	L	L	H	H	H	NC → ON NC	→																														
H	L	L	H	L	L	L	NC → OFF NC	→																														
H	L	L	H	L	L	H	NC → ON NC	→																														
H	L	L	H	L	H	L	NC → OFF NC	→																														
H	L	L	H	L	H	H	NC → ON NC	→																														
H	L	L	H	H	L	L	NC → OFF NC	→																														
H	L	L	H	H	L	H	NC → ON NC	→																														
⋮	⋮	⋮	⋮	⋮	⋮	⋮	⋮	⋮																														
H	H	H	H	H	H	L	NC	→ OFF																														
H	H	H	H	H	H	H	NC	→ ON																														

TIMING DIAGRAM

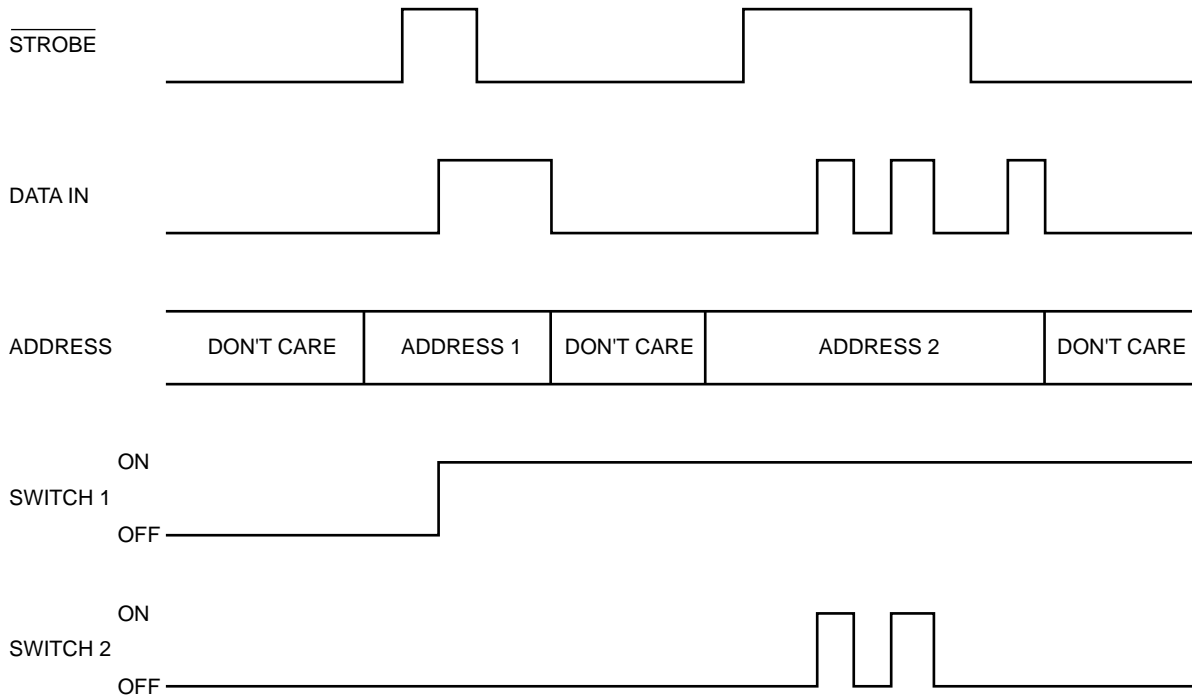

BLOCK DIAGRAM

■ μPD22100

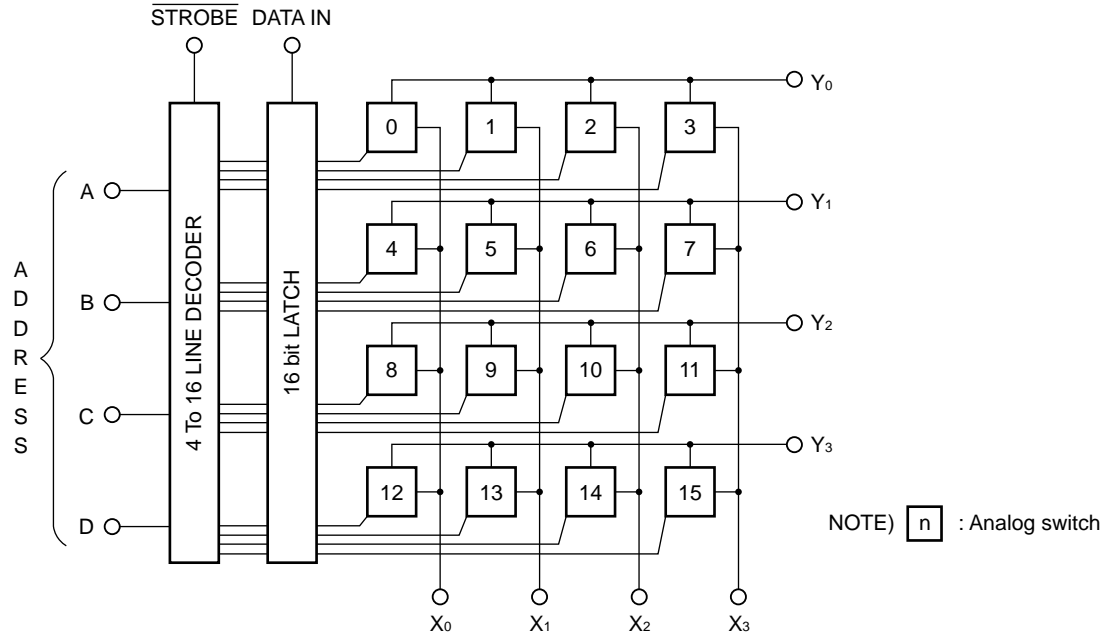

■ μPD22148

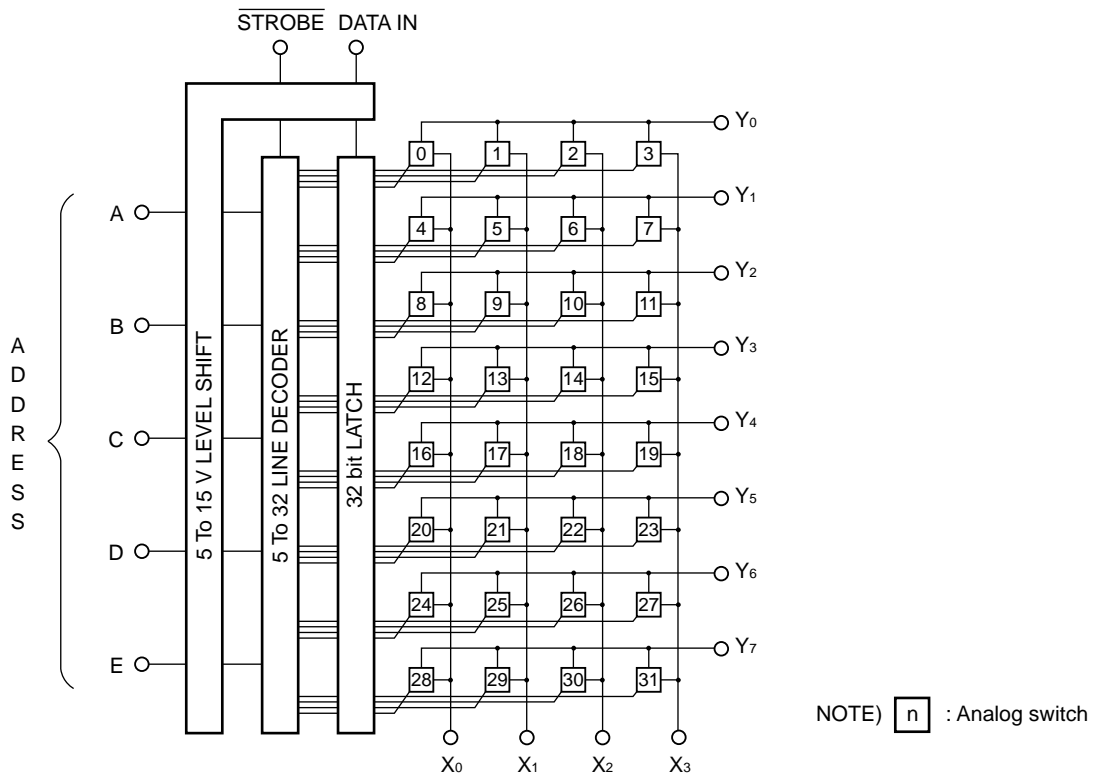

CONNECTION DIAGRAM (TOP VIEW)

■ μ PD22100

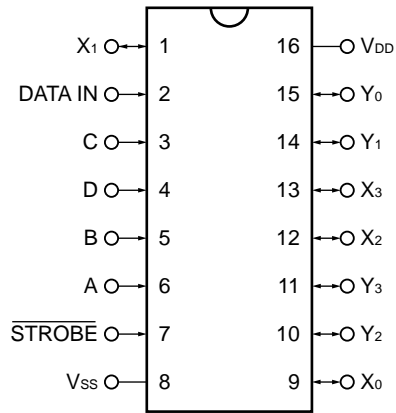

■ μ PD22148

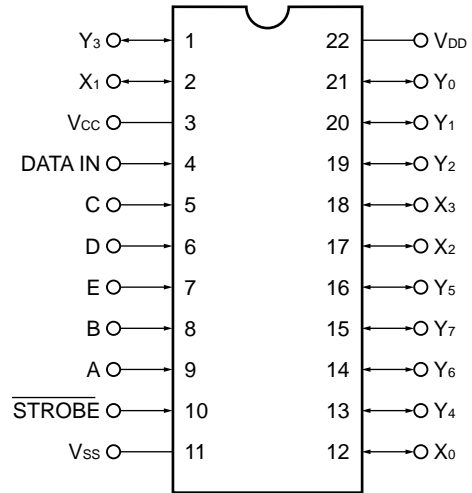

■ μPD22100

ABSOLUTE MAXIMUM RATINGS (Ta = 25 °C, Vss = 0 V)

DC Supply Voltage	V _{DD}	-0.5 to +20	V
Input Voltage	V _I	-0.5 to V _{DD} + 0.5	V
Input Current	I _I	10	mA
Power Dissipation	P _D	200	mW
Operating Temperature	T _{opt}	-40 to +85	°C
Storage Temperature	T _{stg}	-65 to +125	°C

RECOMMENDED OPERATING CONDITIONS (Ta = -40 to +85 °C)

CHARACTERISTIC	SYMBOL	MIN.	TYP.	MAX.	UNIT	CONDITIONS
Operating Voltage	V _{DD}	3		18	V	
Input Voltage (Control)	V _{IH}	0.7 V _{DD}		V _{DD}	V	
Input Voltage (Control)	V _{IL}	0		0.3 V _{DD}	V	
Analog Input Voltage	V _{IA}	V _{SS}		V _{DD}	V	V _{xn} - V _{yn} ≤ 0.5 V

ELECTRICAL CHARACTERISTICS

CHARACTERISTIC	SYMBOL	Ta = -40 °C		Ta = 25 °C			Ta = +85 °C		UNIT	V _{DD} (V)	CONDITIONS
		MIN.	MAX.	MIN.	TYP.	MAX.	MIN.	MAX.			
On-State Resistance	R _{ON}		530		160	650		820	Ω	5	$V_{IS} = \frac{V_{DD} - V_{SS}}{2}$
			100		80	120		150		10	
			75		70	90		120		12	
			70		60	85		110		15	
On-State Resistance Difference Between Any Two Switches	ΔR _{ON}				35				Ω	5	$V_{IS} = \frac{V_{DD} - V_{SS}}{2}$
					20					10	
					18					12	
					15					15	
Input Leakage Current	I _L		±300		±1	±300		±10000	nA	18	All Switches OFF
Input Voltage	V _{IH}	3.5		3.5				3.5	V	5	Switch ON R _{ON} < R _{ON} MAX.
		7		7				7		10	
		11		11				11		15	
Input Voltage	V _{IL}		1.5			1.5		1.5	V	5	Switch OFF I _L < 0.2 μA
			3			3		3		10	
			4			4		4		15	
Input Current	I _I		±0.3		±10 ⁻⁵	±0.3		±1	μA	18	V _I = V _{SS} , V _{DD}
Quiescent Current	I _{DD}		5		0.04	5		150	μA	5	V _I = V _{SS} , V _{DD}
			10		0.04	10		300		10	
			20		0.04	20		600		15	
			100		0.08	100		3000		20	



SWITCHING TIME CHARACTERISTICS (T_a = 25 °C)

CHARACTERISTIC	SYMBOL	MIN.	TYP.	MAX.	UNIT	V _{DD} (V)	CONDITIONS		
Propagation Delay Time	t _{PLH} t _{PHL}		30	60	ns	5	Signal INPUT → Signal OUTPUT R _L = 10 kΩ, C _L = 50 pF. t _r = t _f = 20 ns		
			15	30		10			
			10	20		15			
	t _{PZH}		300	600	ns	5	Strobe INPUT → OUTPUT R _L = 1 kΩ C _L = 50 pF t _r , t _f = 20 ns		
			125	250		10			
			80	160		15			
	t _{PZH}		210	420	ns	5	Data INPUT → OUTPUT		
			110	220		10			
			100	150		15			
	t _{PZL}		350	700	ns	5	Address INPUT → OUTPUT		
			135	270		10			
			90	180		15			
	t _{PHZ}		165	330	ns	5	Strobe INPUT → OUTPUT		
			85	170		10			
			70	140		15			
	t _{PZL}		210	420	ns	5	Data INPUT → OUTPUT		
			110	220		10			
			100	150		15			
	t _{PHZ}		435	870	ns	5	Address INPUT → OUTPUT		
			210	420		10			
			160	320		15			
	Set Up Time	t _{set up}		95	190	ns	5	Data INPUT Strobe → Address	
				25	50		10		
				15	30		15		
Hold Time	t _{hold}		180	360	ns	5	Data INPUT Strobe INPUT → Address INPUT		
			110	220		10			
			60	120		15			
Frequency	f _{φmax.}	0.6	1.2		MHz	5	R _L = 1 kΩ, C _L = 50 pF t _r , t _f = 20 ns		
		1.6	3.2			10			
		2.5	5			15			
Strobe Pulse Width	PW (STROBE)		300	600	ns	5			
			120	240		10			
			90	190		15			
Crosstalk Voltage		75			mV (peak)	10	R _L = 10 kΩ t _r = t _f = 20 ns Rectronglar		
INPUT Capacitance	C _{IN}		5	7.5	pF		Data, Strobe, Address INPUT		
			30		pF		Signal	X _n	
			30		pF		INPUT	Y _n	
Feedthrough Capacitance	C _{IN/OUT}	0.4			pF				
Frequency Response (Switch ON)	—		40		MHz	10	R _L = 1 kΩ, V _{IS} = 5 V _(p-p) 20 log $\frac{V_{OS}}{V_{IS}}$ = -3 dB		
Feedthrough Attenuation (Switch Off)	—		-80		dB	10	R _L = 1 kΩ, f = 1.6 kHz, V _{IS} = 5 V _(p-p) Sine Wave Input		
Sine Wave Distortion	—		0.5		%	10	R _L = 1 kΩ, V _{IS} = 5 V _(p-p) f = 1 kHz		
Crosstalk Between Any Two Switches	—		1.5		MHz	10	R _L = 1 kΩ SW(A) = ON SW(B) = OFF	20 log $\frac{V_O(B)}{V_I(A)}$ = -40 dB	



■ μPD22148

ABSOLUTE MAXIMUM RATINGS (T_a = 25 °C, V_{SS} = 0 V)

DC Supply Voltage 1	V _{DD}	V _{CC} to +20	V
DC Supply Voltage 2	V _{CC}	-0.5 to +6	V
Input Voltage	V _I	-0.5 to V _{CC} + 0.5	V
Input Voltage (Analog)	V _{IA}	-0.5 to V _{DD} + 0.5	V
Input Current	I _I	±10	mA
Power Dissipation	P _D	200	mW
Operating Temperature	T _{opt}	-40 to +85	°C
Storage Temperature	T _{stg}	-65 to +125	°C

RECOMMENDED OPERATING CONDITIONS (T_a = -40 to +85 °C)

CHARACTERISTIC	SYMBOL	MIN.	TYP.	MAX.	UNIT	CONDITIONS
Operating Voltage 1	V _{DD}	V _{CC}		18	V	
Operating Voltage 2	V _{CC}	4.5	5	5.5	V	
Input Voltage (Control)	V _{IH}	0.7 V _{CC}		V _{CC}	V	
Input Voltage (Control)	V _{IL}	0		0.3 V _{CC}	V	
Analog Input Voltage	V _{IA}	V _{SS}		V _{DD}	V	V _{xn} - V _{yn} ≤ 0.5 V

ELECTRICAL CHARACTERISTICS

CHARACTERISTIC	SYMBOL	T _a = -40 °C		T _a = 25 °C			T _a = +85 °C		UNIT	V _{DD} (V)	CONDITIONS
		MIN.	MAX.	MIN.	TYP.	MAX.	MIN.	MAX.			
On-State Resistance	R _{ON}		530		160	650		820	Ω	5	$V_{IS} = \frac{V_{DD} - V_{SS}}{2}$
			100		80	120		150		10	
			75		70	90		120		12	
			70		60	85		110		15	
On-State Resistance Difference Between Any Two Switches	ΔR _{ON}				35				Ω	5	$V_{IS} = \frac{V_{DD} - V_{SS}}{2}$
					20					10	
					18					12	
					15					15	
Input Leakage Current	I _L		±300		±1	±300		±10000	nA	18	All Switches OFF
Input Voltage	V _{IH}	3.5		3.5				3.5	V	—	V _{CC} = 5 V V _{DD} > 10 V
Input Voltage	V _{IL}		1.5			1.5		1.5	V	—	V _{CC} = 5 V V _{DD} > 10 V
Input Current	I _I		±0.3		±10 ⁻⁵	±0.3		±1	μA	—	V _{CC} = 6 V V _I = V _{SS} , V _{CC}
Quiescent Current	I _{DD}		10		0.08	10		300	μA	5	V _I = V _{SS} , V _{DD}
			20		0.08	20		600		10	
			40		0.16	40		1200		15	



SWITCHING TIME CHARACTERISTICS (T_a = 25 °C)

CHARACTERISTIC	SYMBOL	MIN.	TYP.	MAX.	UNIT	V _{DD} (V)	CONDITIONS		
Propagation Delay Time	t _{PLH} t _{PHL}		30	60	ns	5	Signal INPUT → Signal OUTPUT R _L = 10 kΩ, C _L = 50 pF. t _r = t _f = 20 ns		
			15	30		10			
			10	20		15			
	t _{PZH}		400	800	ns	5	Strobe INPUT → OUTPUT R _L = 1 kΩ C _L = 50 pF t _r , t _f = 20 ns		
			225	450		10			
			180	360		15			
	t _{PZH}		310	620	ns	5	Data INPUT → OUTPUT		
			220	440		10			
			200	400		15			
	t _{PZH}		450	900	ns	5	Address INPUT → OUTPUT		
			235	470		10			
			190	380		15			
	t _{PHZ}		265	530	ns	5	Strobe INPUT → OUTPUT		
			185	370		10			
			170	340		15			
	t _P		310	620	ns	5	Data INPUT → OUTPUT		
			210	420		10			
			200	400		15			
	t _{PHZ}		535	1070	ns	5	Address INPUT → OUTPUT		
			310	720		10			
			260	520		15			
	Set Up Time	t _{set up}		140	280	ns	5	Data INPUT Strobe → Address	
				70	140		10		
				60	120		15		
Hold Time	t _{hold}		270	540	ns	5	Data INPUT Strobe INPUT → Address INPUT		
			180	360		10			
			110	220		15			
Frequency	f _{φmax.}	0.6	1.2		MHz	5	R _L = 1 kΩ, C _L = 50 pF t _r , t _f = 20 ns		
		1.6	3.2			10			
		2.5	5			15			
Strobe Pulse Width	PW (STROBE)		300	600	ns	5			
			120	240		10			
			90	190		15			
Crosstalk Voltage		75			mV (peak)	10	R _L = 10 kΩ t _r = t _f = 20 ns Rectronglar		
INPUT Capacitance	C _{IN}		5	7.5	pF		Data, Strobe, Address INPUT		
			105		pF		Signal	X _n	
			75				INPUT	Y _n	
Feedthrough Capacitance	C _{IN/OUT}		1.1		pF				
Frequency Response (Switch ON)	—		15		MHz	10	R _L = 1 kΩ, V _{IS} = 5 V _(p-p) 20 log $\frac{V_{OS}}{V_{IS}}$ = -3 dB		
Feedthrough Attenuation (Switch Off)	—		-60		dB	10	R _L = 1 kΩ, f = 1.6 kHz, V _{IS} = 5 V _(p-p) Sine Wave Input		
Sine Wave Distortion	—		0.5		%	10	R _L = 1 kΩ, V _{IS} = 5 V _(p-p) f = 1 kHz		
Crosstalk Between Any Two Switches	—		1.5		MHz	10	R _L = 1 kΩ SW(A) = ON SW(B) = OFF	20 log $\frac{V_O(B)}{V_I(A)}$ = -40 dB V _{CC} = 5 V	



TEST CIRCUITS

■ PROPAGATION DELAY TIMES

(1) SIGNAL INPUT \rightarrow SIGNAL OUTPUT

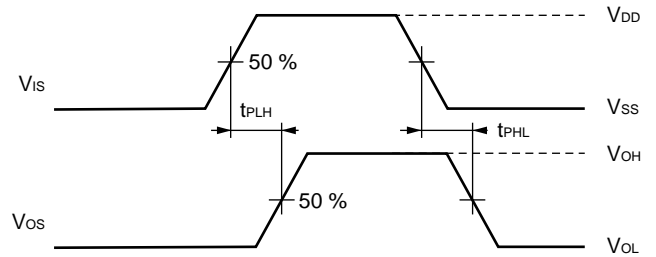
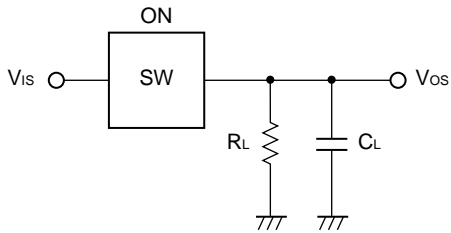

(2) STROBE INPUT \rightarrow OUTPUT

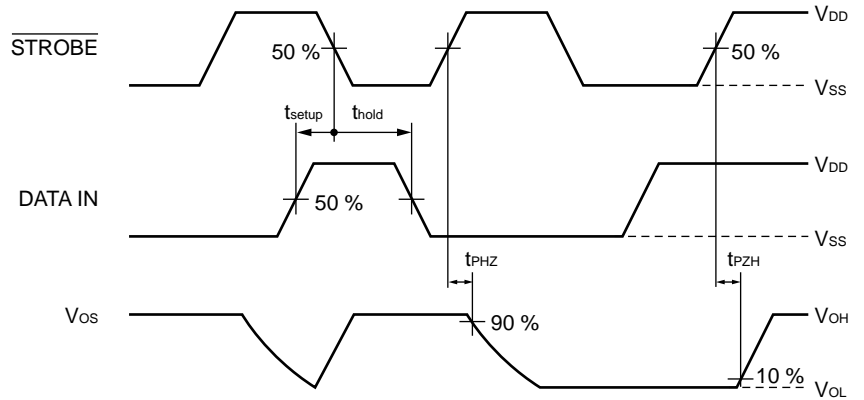
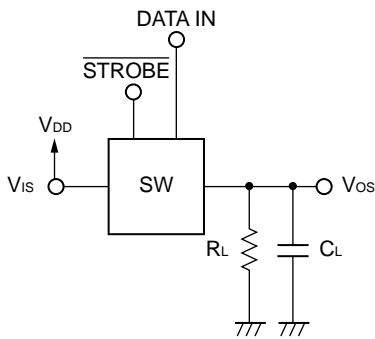

(3) DATA INPUT \rightarrow OUTPUT ($\overline{\text{STROBE}} = V_{DD}$)

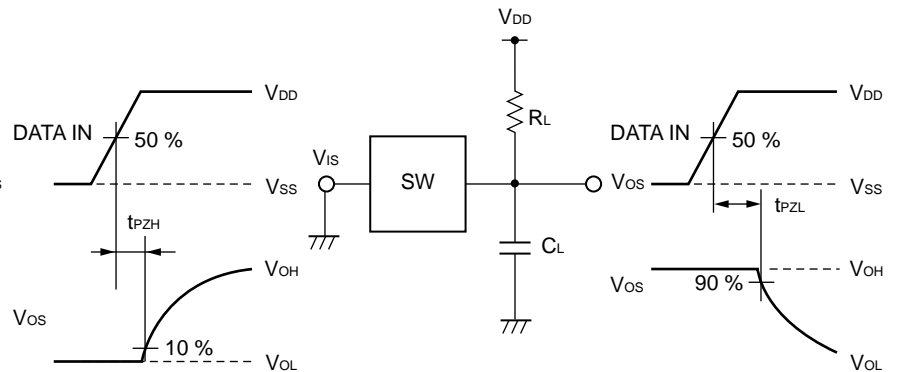
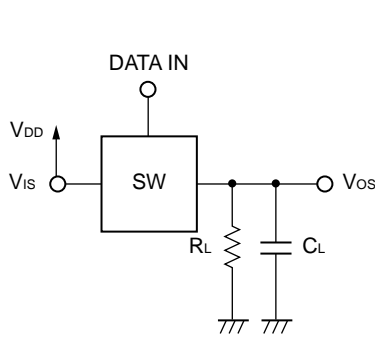

(4) ADDRESS INPUT → OUTPUT ($\overline{\text{STROBE}} = V_{DD}$)

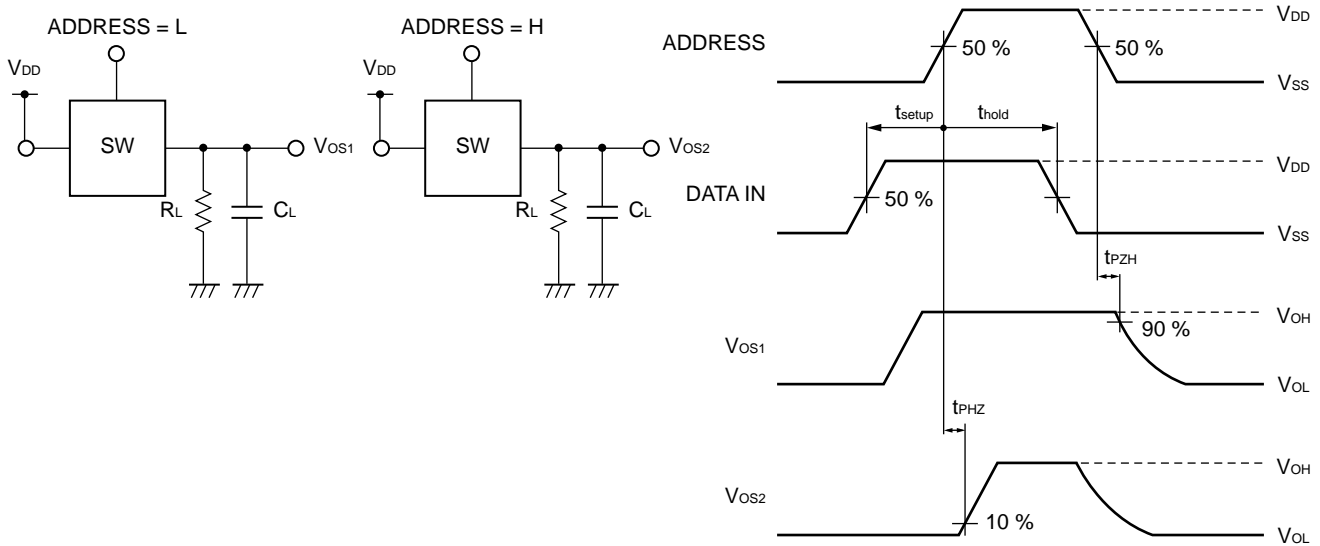

■ CROSSTALK VOLTAGE

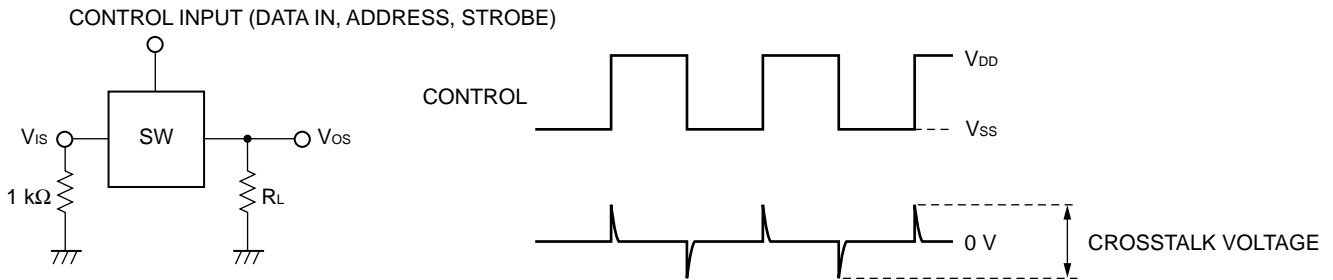

■ CROSSTALK FREQUENCY

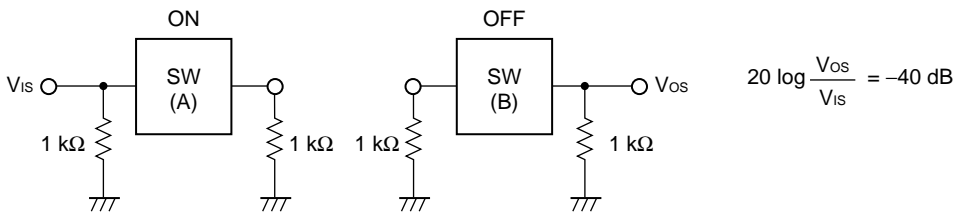

TYPICAL CHARACTERISTICS ($T_a = 25\text{ }^\circ\text{C}$)

(A) $R_{ON} - V_{IS}$ Characteristics

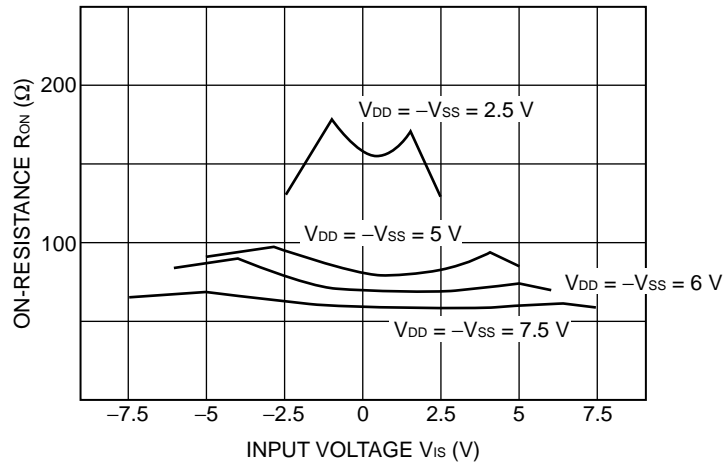

(B) Crosstalk Frequency Characteristics

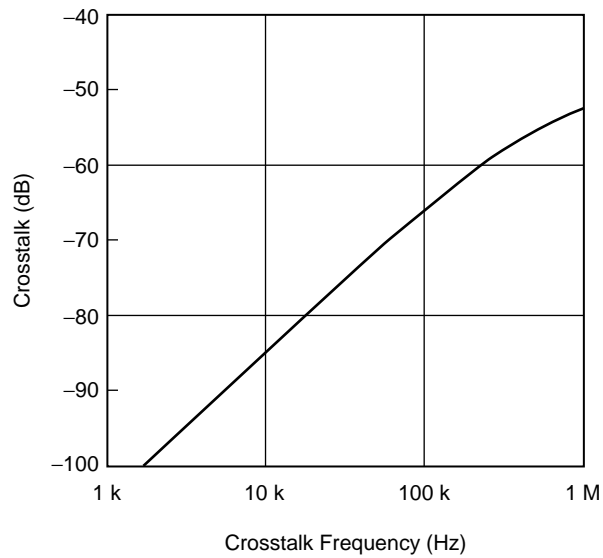

APPLICATION CIRCUITS

■ μ PD22100

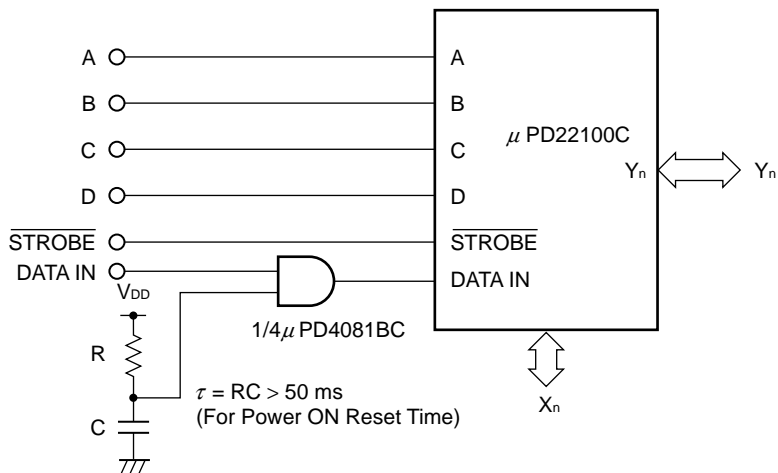

■ μ PD22100/22148 BIAS CIRCUIT

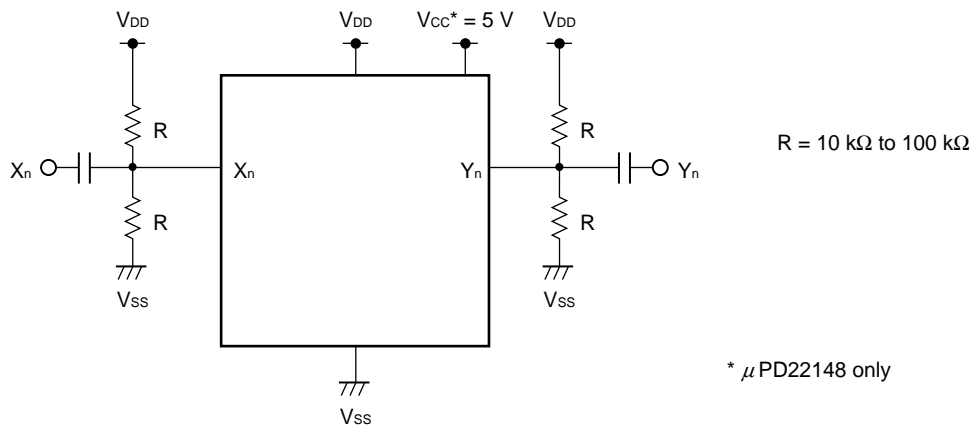

16PIN PLASTIC DIP (300 mil)

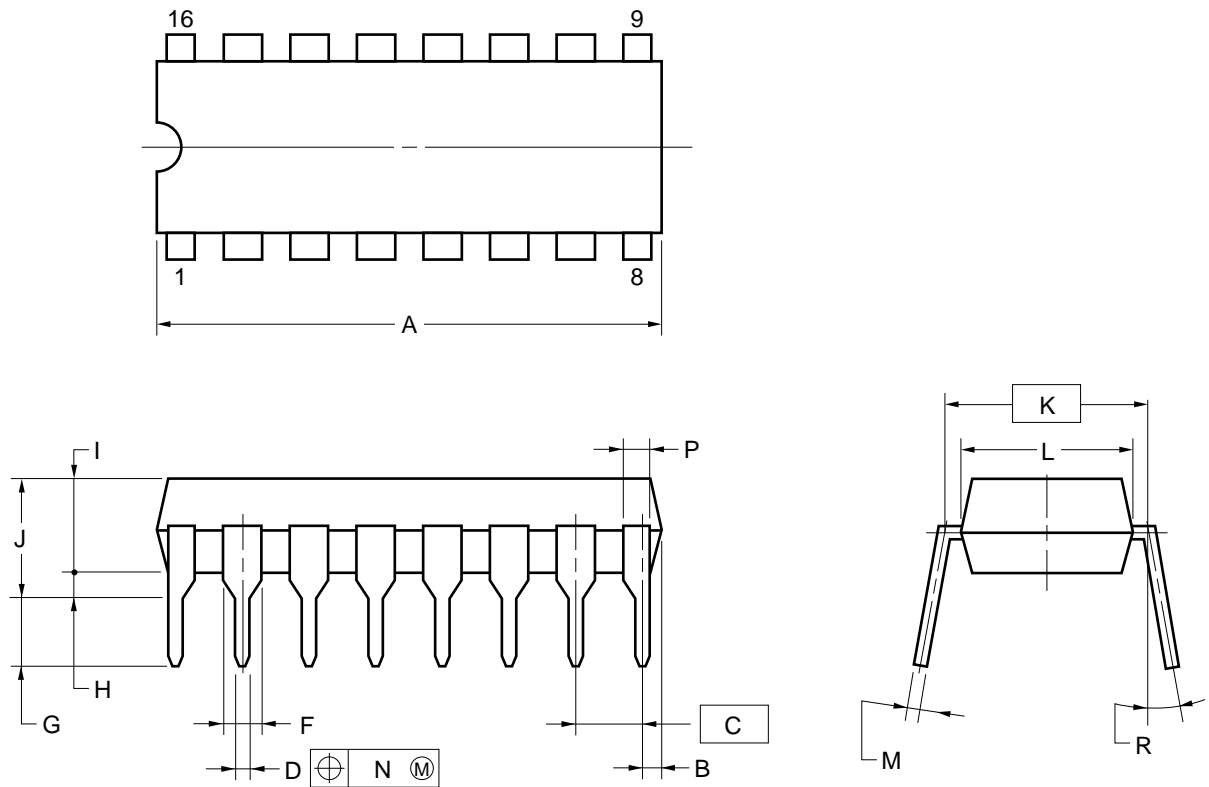

NOTES

- 1) Each lead centerline is located within 0.25 mm (0.01 inch) of its true position (T.P.) at maximum material condition.
- 2) Item "K" to center of leads when formed parallel.

ITEM	MILLIMETERS	INCHES
A	20.32 MAX.	0.800 MAX.
B	1.27 MAX.	0.050 MAX.
C	2.54 (T.P.)	0.100 (T.P.)
D	0.50±0.10	0.020 ^{+0.004} _{-0.005}
F	1.2 MIN.	0.047 MIN.
G	3.5±0.3	0.138±0.012
H	0.51 MIN.	0.020 MIN.
I	4.31 MAX.	0.170 MAX.
J	5.08 MAX.	0.200 MAX.
K	7.62 (T.P.)	0.300 (T.P.)
L	6.4	0.252
M	0.25 ^{+0.10} _{-0.05}	0.010 ^{+0.004} _{-0.003}
N	0.25	0.01
P	1.0 MIN.	0.039 MIN.
R	0~15°	0~15°

P16C-100-300A,C-1



16 PIN PLASTIC SOP (300 mil)

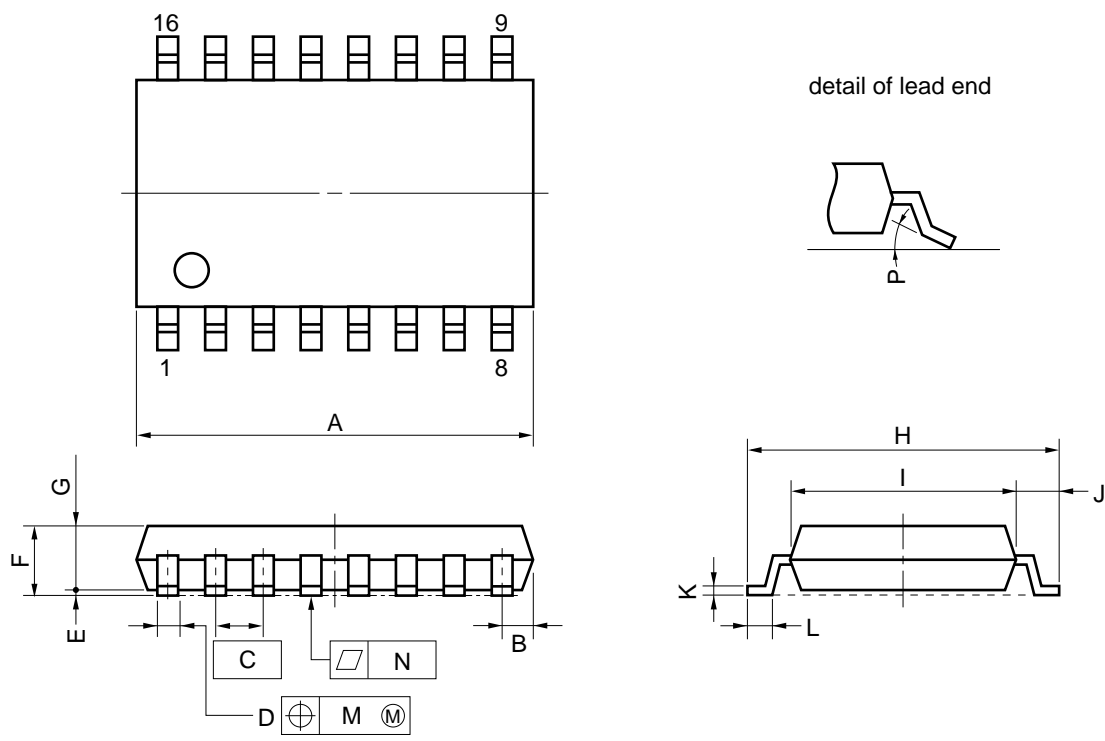

NOTE

Each lead centerline is located within 0.12 mm (0.005 inch) of its true position (T.P.) at maximum material condition.

ITEM	MILLIMETERS	INCHES
A	10.46 MAX.	0.412 MAX.
B	0.78 MAX.	0.031 MAX.
C	1.27 (T.P.)	0.050 (T.P.)
D	0.40 ^{+0.10} _{-0.05}	0.016 ^{+0.004} _{-0.003}
E	0.1±0.1	0.004±0.004
F	1.8 MAX.	0.071 MAX.
G	1.55	0.061
H	7.7±0.3	0.303±0.012
I	5.6	0.220
J	1.1	0.043
K	0.20 ^{+0.10} _{-0.05}	0.008 ^{+0.004} _{-0.002}
L	0.6±0.2	0.024 ^{+0.008} _{-0.009}
M	0.12	0.005
N	0.10	0.004
P	3° ^{+7°} _{-3°}	3° ^{+7°} _{-3°}

P16GM-50-300B-4



22 PIN PLASTIC SHRINK DIP (300 mil)

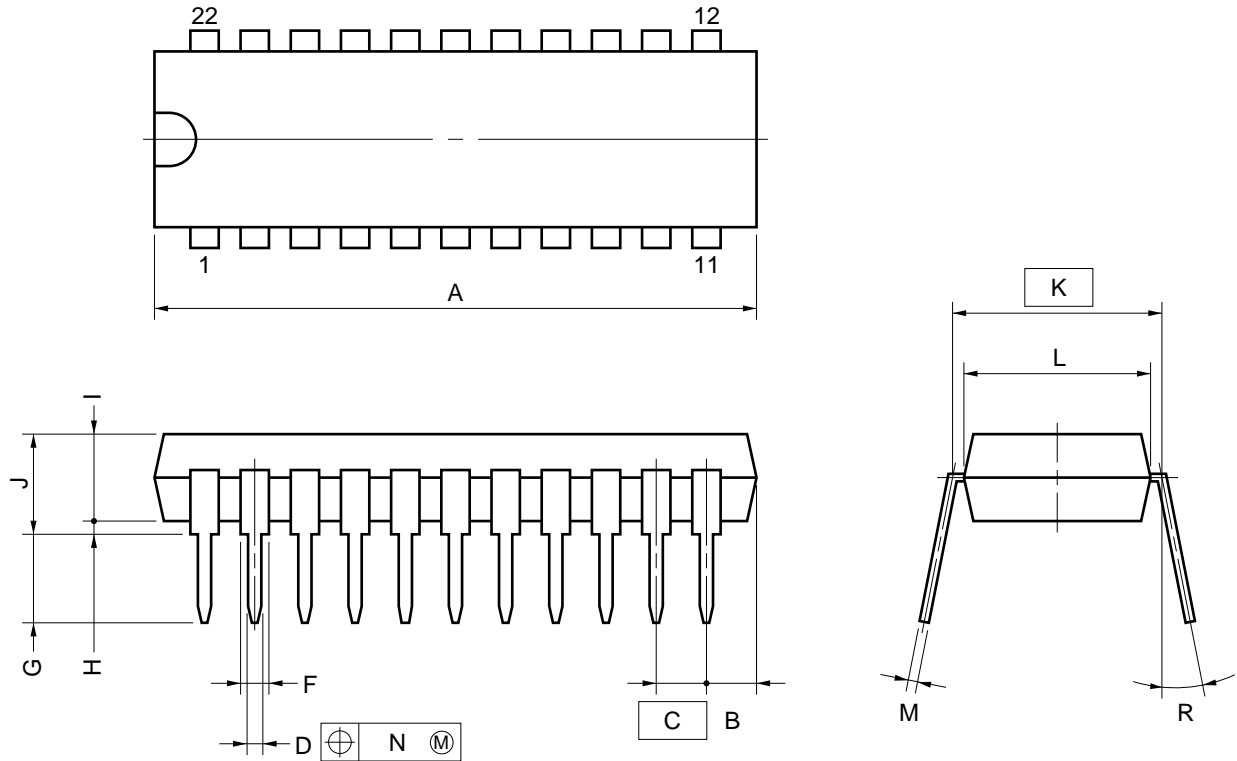

NOTES

- 1) Each lead centerline is located within 0.17 mm (0.007 inch) of its true position (T.P.) at maximum material condition.
- 2) Item "K" to center of leads when formed parallel.

ITEM	MILLIMETERS	INCHES
A	23.12 MAX.	0.911 MAX.
B	2.67 MAX.	0.106 MAX.
C	1.778 (T.P.)	0.070 (T.P.)
D	0.50±0.10	0.020 ^{+0.004} _{-0.005}
F	0.85 MIN.	0.033 MIN.
G	3.2±0.3	0.126±0.012
H	0.51 MIN.	0.020 MIN.
I	4.31 MAX.	0.170 MAX.
J	5.08 MAX.	0.200 MAX.
K	7.62 (T.P.)	0.300 (T.P.)
L	6.5	0.256
M	0.25 ^{+0.10} _{-0.05}	0.010 ^{+0.004} _{-0.003}
N	0.17	0.007
R	0~15°	0~15°

S22C-70-300B-1



No part of this document may be copied or reproduced in any form or by any means without the prior written consent of NEC Corporation. NEC Corporation assumes no responsibility for any errors which may appear in this document.

NEC Corporation does not assume any liability for infringement of patents, copyrights or other intellectual property rights of third parties by or arising from use of a device described herein or any other liability arising from use of such device. No license, either express, implied or otherwise, is granted under any patents, copyrights or other intellectual property rights of NEC Corporation or others.

While NEC Corporation has been making continuous effort to enhance the reliability of its semiconductor devices, the possibility of defects cannot be eliminated entirely. To minimize risks of damage or injury to persons or property arising from a defect in an NEC semiconductor device, customers must incorporate sufficient safety measures in its design, such as redundancy, fire-containment, and anti-failure features.

NEC devices are classified into the following three quality grades:

"Standard", "Special", and "Specific". The Specific quality grade applies only to devices developed based on a customer designated "quality assurance program" for a specific application. The recommended applications of a device depend on its quality grade, as indicated below. Customers must check the quality grade of each device before using it in a particular application.

Standard: Computers, office equipment, communications equipment, test and measurement equipment, audio and visual equipment, home electronic appliances, machine tools, personal electronic equipment and industrial robots

Special: Transportation equipment (automobiles, trains, ships, etc.), traffic control systems, anti-disaster systems, anti-crime systems, safety equipment and medical equipment (not specifically designed for life support)

Specific: Aircrafts, aerospace equipment, submersible repeaters, nuclear reactor control systems, life support systems or medical equipment for life support, etc.

The quality grade of NEC devices is "Standard" unless otherwise specified in NEC's Data Sheets or Data Books. If customers intend to use NEC devices for applications other than those specified for Standard quality grade, they should contact an NEC sales representative in advance.

Anti-radioactive design is not implemented in this product.

