

AMC Doc. #: AMC7587_C
January 2002



AMC7587 1.5A LOW DROPOUT REGULATOR

DESCRIPTION	FEATURES
<p>The AMC7587 is a high performance low dropout regulator rated for 1.5A output current with fixed 1.8V/2.5V/3.3V/5.0V and adjustable output. It is designed for use in applications requiring low dropout characteristics over the rated current range.</p> <p>On chip trimming adjusts the reference voltage to 1%. These features are ideal for low voltage microprocessor applications requiring a regulated 2.5V to 3.6V power supply.</p> <p>In addition, the AMC7587 provides the device protections including over current and thermal shutdown. Also, reverse battery protection scheme limits the reverse current when the input voltage falls below the output.</p>	<ul style="list-style-type: none"> ■ Input-Output differential of typical 1.1V at 1.5A and low quiescent current ■ Output current is excess of 1.5A <ul style="list-style-type: none"> □ Fast transient response □ Reverse battery protection □ Short circuit protection □ Internal thermal overload protection □ Available in 3L plastic TO-220, surface mount 3L TO-263/252, and SOT223 packages □ Pin assignment identical to EZ1585B and LT1585A series.

APPLICATIONS	PACKAGE PIN OUT
--------------	-----------------

- Pentium® Processor Supplies
- PowerPC™ Supplies
- Computer Add-On Cards
- Other Applications Requiring Low Dropout Voltage Over Rated Current.

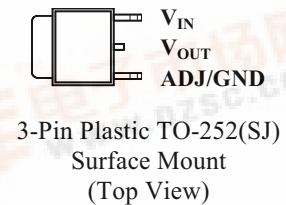
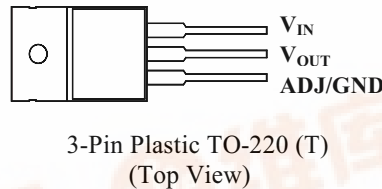

- AMC7587-1.8 – 1.8V Fixed
- AMC7587-2.5 – 2.5V Fixed
- AMC7587-3.3 – 3.3V Fixed
- AMC7587-5.0 – 5.0V Fixed
- AMC7587-ADJ – Adjustable

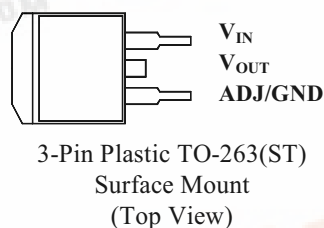

ORDER INFORMATION								
T _A (°C)	T	TO-220	ST	TO-263	SK	SOT-223	SJ	TO-252
		3-pin		3-pin		3-pin		3-pin
0 to 70		AMC7587-X.XT		AMC7587-X.XST		AMC7587-X.XSK		AMC7587-X.XSJ
0 to 70		AMC7587-ADJT		AMC7587-ADJST		AMC7587-ADJSK		AMC7587-ADJSJ
Note: All surface-mount packages are available in Tape & Reel. Append the letter "T" to part number (i.e., AMC7587-X.XSTT, AMC7587-X.XSKT, AMC7587-X.XSJT).								

TYPICAL APPLICATION

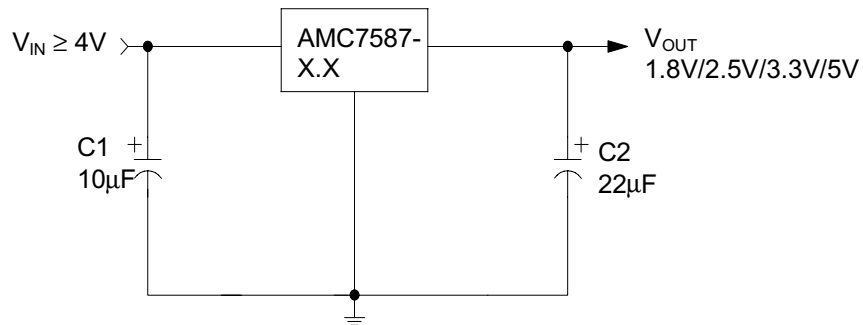

AMC7587-X.X application schematic

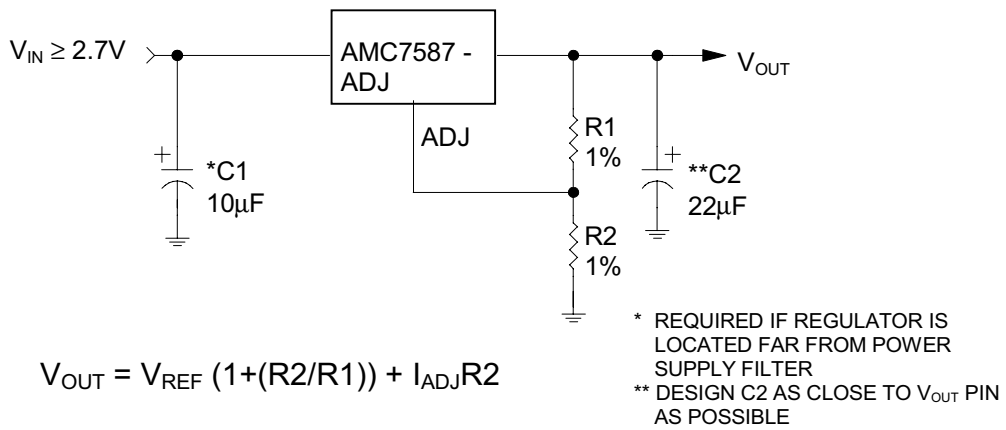

AMC7587-ADJ application schematic



ABSOLUTE MAXIMUM RATINGS (Note 1)	
Input Voltage (V_{IN})	10.5V
Operating Junction temperature	150°C
Storage Temperature Range	-65°C to 150°C
Lead temperature (Soldering, 10 seconds)	300°C
Note 1: Exceeding these ratings could cause damage to the device. All voltages are with respect to Ground. Currents are positive into, negative out of the specified terminal.	

POWER DISSIPATION TABLE					
Package	θ_{JA} (°C/W)	Derating factor (mW/°C) $T_A \geq 25^\circ\text{C}$	$T_A \leq 25^\circ\text{C}$	$T_A = 70^\circ\text{C}$	$T_A = 85^\circ\text{C}$
			Power rating(mW)	Power rating(mW)	Power rating (mW)
T	45	22.2	2775	1776	1443
ST/ST3	45	22.2	2775	1776	1443
SJ	80	12.5	1562	1000	812
SK	136	7.35	919	588	478
Note : 1. θ_{JA} : Thermal Resistance-Junction to Ambient, D_F : Derating factor, P_o : Power consumption. Junction Temperature Calculation: $T_J = T_A + (P_D \times \theta_{JA})$, $P_o = D_F \times (T_J - T_A)$ The θ_{JA} numbers are guidelines for the thermal performance of the device/PC-board system. All of the above assume no ambient airflow. 2. θ_{JT} : Thermal Resistance-Junction to Ambient, T_C : case(Tab) temperature, $T_J = T_C + (P_D \times \theta_{JT})$ For T and ST/ST3 packages, $\theta_{JT} = 3.0^\circ\text{C}/\text{W}$. For SJ package, $\theta_{JT} = 7.0^\circ\text{C}/\text{W}$. For SK package, $\theta_{JT} = 15.0^\circ\text{C}/\text{W}$ 3. If power consumption is over above rating, adequate heat sink is required to dissipate heat.					

RECOMMENDED OPERATING CONDITIONS					
Parameter	Symbol	Recommended Operating Conditions			Units
		Min.	Typ.	Max.	
Input Voltage	V_{IN}	2.7		10	V
Load Current (with adequate heatsinking)	I_o	0.010		1.5	A
Input Capacitor (V_{IN} to GND)		1			μF
Output Capacitor with ESR of 10 Ω max., (V_{OUT} to GND)		10			μF
Operating Ambient Temperature Range		0		70	°C



BLOCK DIAGRAM

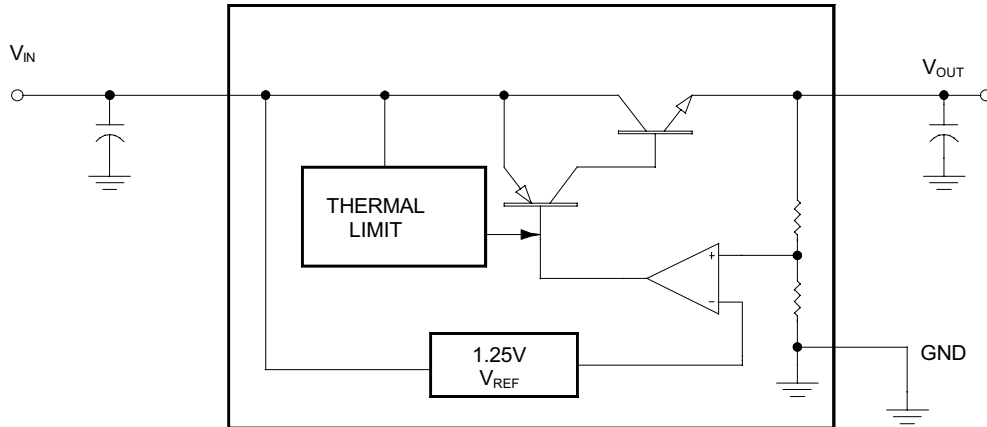

AMC7587-X.X circuit schematic

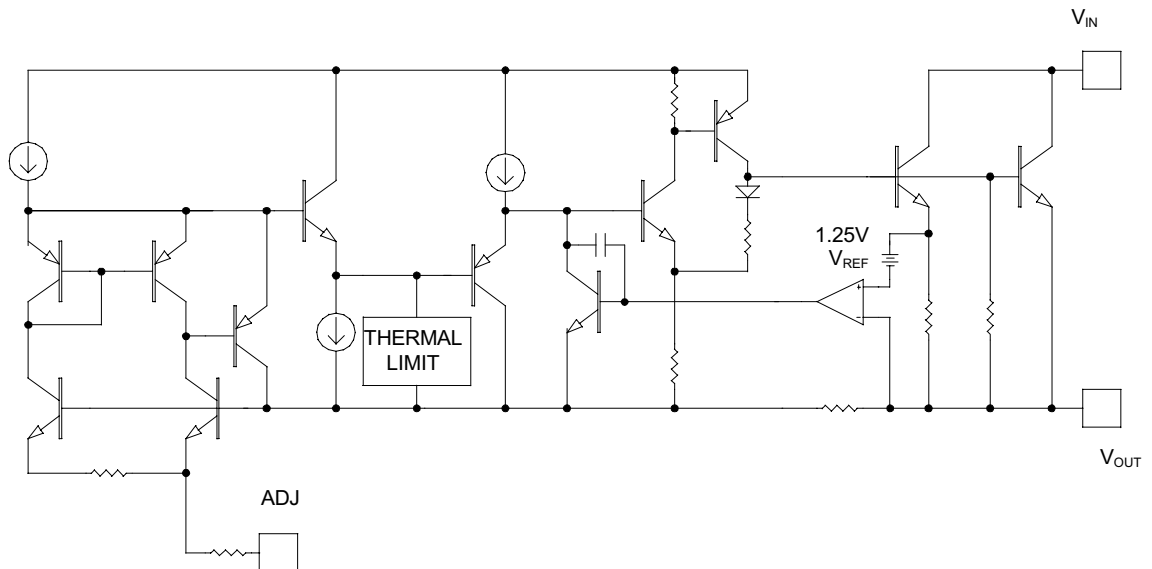

AMC7587-ADJ circuit schematic



ELECTRICAL CHARACTERISTICS							
Unless otherwise specified, $V_{IN} = V_{OUT} + 2V$, $I_O = 10mA$. These specifications apply operating ambient temperature range, and are for DC characteristics only. (Low duty cycle pulse testing techniques are used which maintains junction and case temperatures equal to the ambient temperature.)							
Parameter	Symbol	Test Conditions	AMC7587			Units	
			Min.	Typ.	Max.		
Output Voltage	AMC7587-1.8	V_{OUT}	$T_A = 25^\circ C$	1.782	1.800	1.818	V
	AMC7587-2.5		$T_A = 25^\circ C$	2.475	2.500	2.525	
	AMC7587-3.3		$T_A = 25^\circ C$	3.267	3.300	3.333	
	AMC7587-5.0		$T_A = 25^\circ C$	4.950	5.000	5.050	
Output Voltage	AMC7587-1.8	V_{OUT}	$I_O = 10mA \text{ to } 1.5A$	1.771	1.800	1.829	V
	AMC7587-2.5			2.460	2.500	2.540	
	AMC7587-3.3			3.247	3.300	3.353	
	AMC7587-5.0			4.920	5.000	5.080	
Reference Voltage	AMC7587-ADJ	V_{REF}	(Note 1)	1.238	1.250	1.262	V
			$I_O = 10mA \text{ to } 1.5A$, (Note 1)	1.230	1.250	1.270	
Line Regulation (Note 2)	ΔV_{OI}	$(1.5V + V_{OUT}) \leq V_{IN} \leq 10V$			0.04	0.2	%
Load regulation (Note 2)	ΔV_{OL}	$I_O = 10mA \text{ to } 1.5A$			0.08	0.3	%
Dropout Voltage	ΔV	(Note 3)	$I_O = 10mA$		1.00	1.15	V
			$I_O = 1.5A$		1.15	1.30	
Quiescent Current (for AMC7587-X.X)	I_Q	$V_{IN} \leq 10V$, $I_O = 10mA \text{ to } 1.5A$			8	13	mA
Adjust Pin Current (for AMC7587-ADJ)	I_{ADJ}				50	120	μA
Current Limit	I_{CL}	$(V_{IN} - V_{OUT}) = 2V$		1.5	3		A
Minimum Load Current (Note 4)	I_{min}				5	10	mA
Ripple Rejection (Note 5)	R_R	$V_{RIPPLE} = 1V_{PP}$, $I_O = 100mA$, $f_o = 120$ HZ		60	80		dB

Note 1 Output voltage is set to be 2.5V.

Note 2: Line and load regulations are guaranteed up to maximum power dissipation determined by input/output differential and the output current. However, the maximum power will not be available over the full input/output voltage range.

Note 3: The specifications represent the minimum input/output voltage required to maintain 1% regulation.

Note 4: The minimum load current is the minimum current required to maintain regulation. Normally the current in the resistor divider used to set the output voltage is selected to meet the minimum load current requirement.

Note 5: These parameters, although guaranteed, are not tested in production prior to shipment



CHARACTERISTICS CURVES

$C_{IN}=10\mu F$, $C_{OUT}=22\mu F$, $T_A=25^\circ C$, unless otherwise specified.

Load Regulation

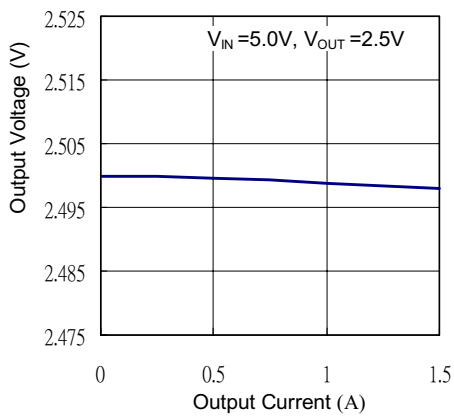

Output Voltage v.s. Temperature

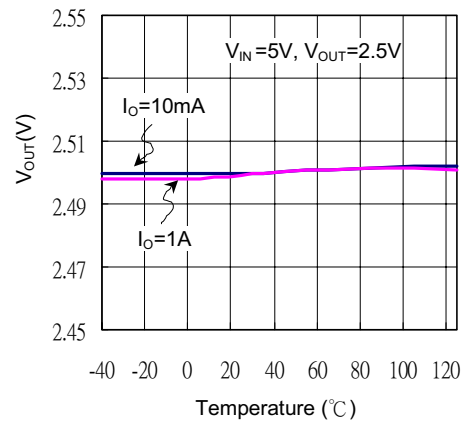

Quiescent Current vs. Temperature

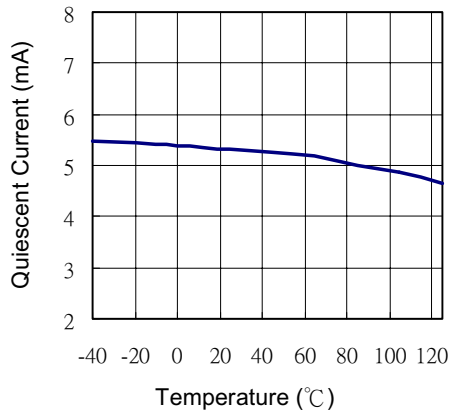

Load Transient Response with $I_O=1A$

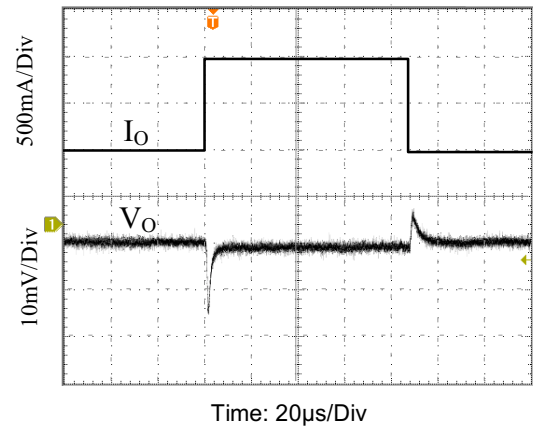

APPLICATION INFORMATION:

• **Thermal Consideration**

Maximum Power Calculation:

$$P_{D(MAX)} = \frac{T_{J(MAX)} - T_{A(MAX)}}{\theta_{JA}}$$

$T_J(^{\circ}C)$: Maximum recommended junction temperature

$T_A(^{\circ}C)$: Ambient temperature of the application

$\theta_{JA}(^{\circ}C/W)$: Junction-to-junction temperature thermal resistance of the package, and other heat dissipating materials.

The maximum power dissipation of a single-output regulator :

$$P_{D(MAX)} = [(V_{IN(MAX)} - V_{OUT(NOM)}) \times I_{OUT(NOM)} + V_{IN(MAX)} \times I_Q]$$

Where: $V_{OUT(NOM)}$ = the nominal output voltage

$I_{OUT(NOM)}$ = the nominal output current, and

I_Q = the quiescent current the regulator consumes at $I_{OUT(MAX)}$

$V_{IN(MAX)}$ = the maximum input voltage

Then $\theta_{JA} = (150^{\circ}C - T_A) / P_D$

Thermal consideration:

When power consumption is over about 1.2W for the devices using TO-220/263 packages (687 mW for TO-252 package, 404mW for SOT223 package) at an environment of 70°C ambient temperature, additional heat sink is required to control the junction temperature below 125°C.

The junction temperature is: $T_j = P_D (\theta_{JT} + \theta_{CS} + \theta_{SA}) + T_A$

$P_D \equiv$ Dissipated power.

$\theta_{JT} \equiv$ Thermal resistance from the junction to the mounting tab of the package.

$\theta_{CS} \equiv$ Thermal resistance through the interface between the IC and the surface on which it is mounted. (typically, $\theta_{CS} < 1.0^{\circ}C/W$)

$\theta_{SA} \equiv$ Thermal resistance from the mounting surface to ambient (thermal resistance of the heat sink).

If PC Board copper is going to be used as a heat sink, below table can be used to determine the appropriate size of copper foil required. For multi-layered PCB, these layers can also be used as a heat sink. They can be connected with several through hole vias.

PCB $\theta_{SA}(^{\circ}C/W)$	59	45	38	33	27	24	21
PCB heat sink size (mm ²)	500	1000	1500	2000	3000	4000	5000

Recommended figure of PCB area used as a heat sink.

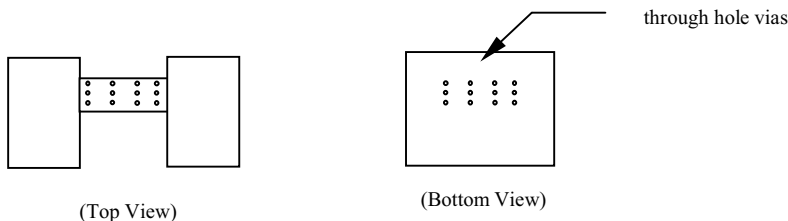

3-Pin Plastic TO-220 (T)

AMC7587

1.5A LOW DROPOUT REGULATOR

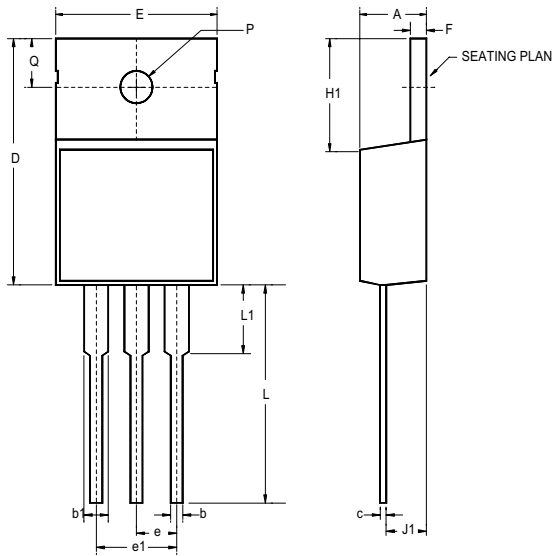

	INCHES			MILLIMETERS		
	MIN	TYP	MAX	MIN	TYP	MAX
A	0.140	-	0.190	3.56	-	4.83
b1	0.045	-	0.070	1.14	-	1.78
b	0.020	-	0.045	0.51	-	1.14
c	0.012	-	0.045	0.30	-	1.14
D	0.560	-	0.650	14.22	-	16.51
E	0.380	-	0.420	9.65	-	10.67
e	0.090	-	0.110	2.29	-	2.79
e1	0.190	-	0.210	4.83	-	5.33
F	0.020	-	0.055	0.51	-	1.40
H1	0.230	-	0.270	5.84	-	6.86
J1	0.080	-	0.115	2.03	-	2.92
L	0.500	-	0.580	12.7	-	14.73
P	0.139	-	0.161	3.53	-	4.09
Q	0.100	-	0.135	2.54	-	3.43
L1	-	-	0.250	-	-	6.35

3-Pin Surface Mount TO-263 (ST)

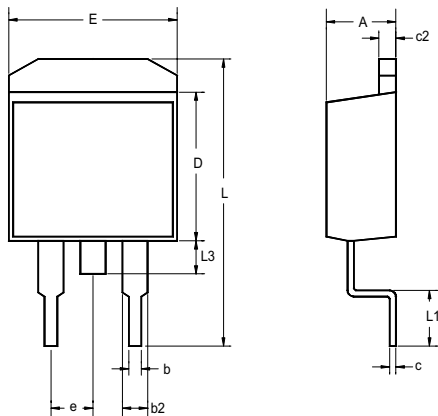

	INCHES			MILLIMETERS		
	MIN	TYP	MAX	MIN	TYP	MAX
A	0.160	-	0.190	4.06	-	4.83
b	0.020	-	0.039	0.51	-	0.99
b2	0.045	-	0.055	1.14	-	1.40
c	0.015 TYP.			0.38 TYP.		
c2	0.045	-	0.055	1.14	-	1.40
D	0.340	-	0.380	8.64	-	9.65
E	0.380	-	0.405	9.65	-	10.29
e	0.100 BSC			2.54 BSC		
L	0.575	-	0.625	14.61	-	15.88
L1	0.090	-	0.110	2.29	-	2.79
L2	-	-	0.115	-	-	2.92
L3	0.050	-	0.070	1.27	-	1.78



3-Pin Surface Mount TO-252 (SJ)

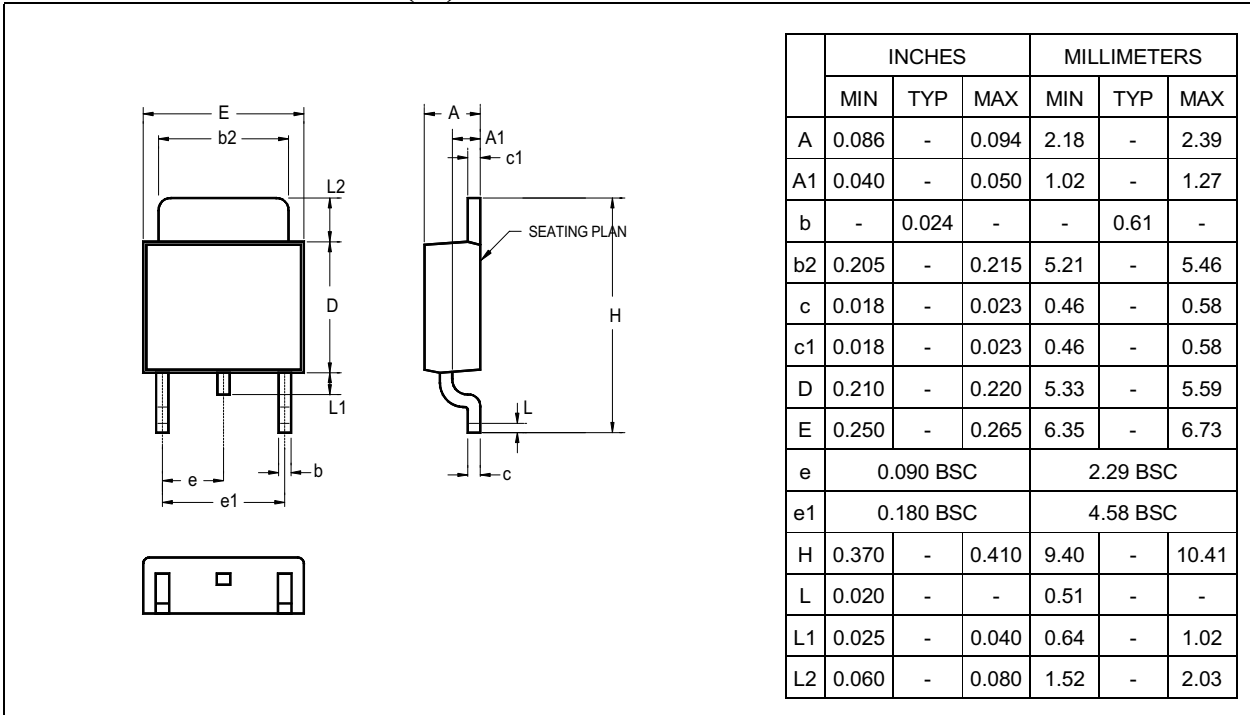

3-Pin Surface Mount SOT-223 (SK)

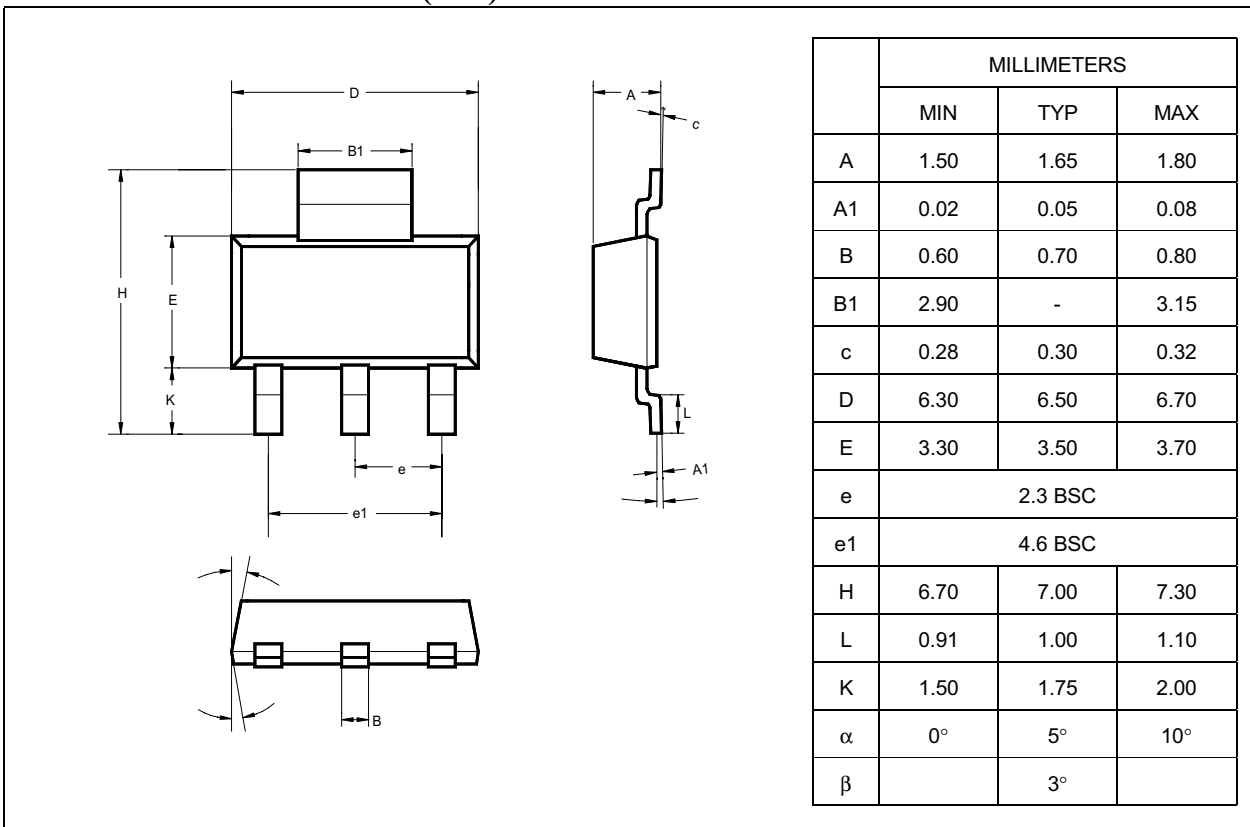

IMPORTANT NOTICE

ADD Microtech (ADDM) reserves the right to make changes to its products or to discontinue any integrated circuit product or service without notice, and advises its customers to obtain the latest version of relevant information to verify, before placing orders, that the information being relied on is current.

A few applications using integrated circuit products may involve potential risks of death, personal injury, or severe property or environmental damage. ADDM integrated circuit products are not designed, intended, authorized, or warranted to be suitable for use in life-support applications, devices or systems or other critical applications. Use of ADDM products in such applications is understood to be fully at the risk of the customer. In order to minimize risks associated with the customer's applications, the customer should provide adequate design and operating safeguards.

ADDM assumes no liability to customer product design or application support. ADDM warrants the performance of its products to the specifications applicable at the time of sale.

U.S.

ADD Microtech Inc.

492 Altamont Drive
Milpitas, CA 95035

TEL: (408) 9410420

FAX: (408) 9410864

Asia Pacific region

ADD Microtech Corp

3F, 132, Sec. 4, Chung Hsiao E. Rd.,
Taipei, Taiwan

TEL: 2-27760166

FAX: 2-27764208

