

May 1989

DM54LS190/DM74LS190, DM54LS191/DM74LS191 Synchronous 4-Bit Up/Down Counters with Mode Control

General Description

These circuits are synchronous, reversible, up/down counters. The LS191 is a 4-bit binary counter and the LS190 is a BCD counter. Synchronous operation is provided by having all flip-flops clocked simultaneously, so that the outputs change simultaneously when so instructed by the steering logic. This mode of operation eliminates the output counting spikes normally associated with asynchronous (ripple clock) counters.

The outputs of the four master-slave flip-flops are triggered on a low-to-high level transition of the clock input, if the enable input is low. A high at the enable input inhibits counting. Level changes at either the enable input or the down/up input should be made only when the clock input is high. The direction of the count is determined by the level of the down/up input. When low, the counter counts up and when high, it counts down.

These counters are fully programmable; that is, the outputs may be preset to either level by placing a low on the load input and entering the desired data at the data inputs. The output will change independent of the level of the clock input. This feature allows the counters to be used as modulo-N dividers by simply modifying the count length with the preset inputs.

The clock, down/up, and load inputs are buffered to lower the drive requirement; which significantly reduces the number of clock drivers, etc., required for long parallel words.

Two outputs have been made available to perform the cascading function: ripple clock and maximum/minimum count. The latter output produces a high-level output pulse with a duration approximately equal to one complete cycle of the clock when the counter overflows or underflows. The ripple clock output produces a low-level output pulse equal in width to the low-level portion of the clock input when an overflow or underflow condition exists. The counters can be easily cascaded by feeding the ripple clock output to the enable input of the succeeding counter if parallel clocking is used, or to the clock input if parallel enabling is used. The maximum/minimum count output can be used to accomplish look-ahead for high-speed operation.

Features

- Counts 8-4-2-1 BCD or binary
- Single down/up count control line
- Count enable control input
- Ripple clock output for cascading
- Asynchronously presettable with load control
- Parallel outputs
- Cascadable for n-bit applications
- Average propagation delay 20 ns
- Typical clock frequency 25 MHz
- Typical power dissipation 100 mW

Connection Diagram

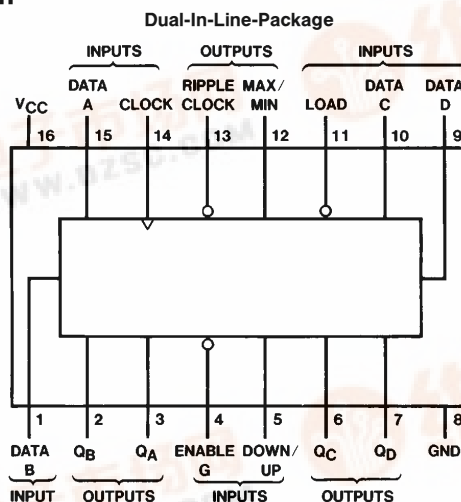

TL/F/6405-1

Order Number DM54LS190J, DM54LS191J, DM54LS190W,
DM54LS191W, DM74LS190M, DM74LS191M, DM74LS190N, or DM74LS191N
See NS Package Number
J16A, M16A, N16A or W16A

DM54LS190/DM74LS190, DM54LS191/DM74LS191
Synchronous 4-Bit Up/Down Counters with Mode Control



Absolute Maximum Ratings (Note)

If Military/Aerospace specified devices are required, please contact the National Semiconductor Sales Office/Distributors for availability and specifications.

Supply Voltage	7V
Input Voltage	7V
Operating Free Air Temperature Range	
DM54LS	-55°C to +125°C
DM74LS	0°C to +70°C
Storage Temperature Range	-65°C to +150°C

Note: The "Absolute Maximum Ratings" are those values beyond which the safety of the device cannot be guaranteed. The device should not be operated at these limits. The parametric values defined in the "Electrical Characteristics" table are not guaranteed at the absolute maximum ratings. The "Recommended Operating Conditions" table will define the conditions for actual device operation.

Recommended Operating Conditions

Symbol	Parameter	DM54LS190, LS191			DM74LS190, LS191			Units
		Min	Nom	Max	Min	Nom	Max	
V _{CC}	Supply Voltage	4.5	5	5.5	4.75	5	5.25	V
V _{IH}	High Level Input Voltage	2			2			V
V _{IL}	Low Level Input Voltage			0.7			0.8	V
I _{OH}	High Level Output Current			-0.4			-0.4	mA
I _{OL}	Low Level Output Current			4			8	mA
f _{CLK}	Clock Frequency (Note 4)	0		20	0		20	MHz
t _w	Pulse Width (Note 4)	Clock	25		25			ns
		Load	35		35			
t _{SU}	Data Setup Time (Note 4)	20			20			ns
t _H	Data Hold Time (Note 4)	0			0			ns
t _{EN}	Enable Time to Clock (Note 4)	30			30			ns
T _A	Free Air Operating Temperature	-55		125	0		70	°C

'LS190 and 'LS191 Electrical Characteristics

over recommended operating free air temperature range (unless otherwise noted)

Symbol	Parameter	Conditions	Min	Typ (Note 1)	Max	Units
V _I	Input Clamp Voltage	V _{CC} = Min, I _I = -18 mA			-1.5	V
V _{OH}	High Level Output Voltage	V _{CC} = Min, I _{OH} = Max V _{IL} = Max, V _{IH} = Min	DM54	2.5	3.4	V
			DM74	2.7	3.4	
V _{OL}	Low Level Output Voltage	V _{CC} = Min, I _{OL} = Max V _{IL} = Max, V _{IH} = Min	DM54		0.25	V
			DM74		0.35	
		I _{OL} = 4 mA, V _{CC} = Min	DM74		0.25	0.4
I _I	Input Current @ Max Input Voltage	V _{CC} = Max V _I = 7V	Enable		0.3	mA
			Others		0.1	
I _{IH}	High Level Input Current	V _{CC} = Max V _I = 2.7V	Enable		60	μA
			Others		20	
I _{IL}	Low Level Input Current	V _{CC} = Max V _I = 0.4V	Enable		-1.08	mA
			Others		-0.4	
I _{OS}	Short Circuit Output Current	V _{CC} = Max (Note 2)	DM54	-20	-100	mA
			DM74	-20	-100	
I _{CC}	Supply Current	V _{CC} = Max (Note 3)		20	35	mA

Note 1: All typicals are at V_{CC} = 5V, T_A = 25°C.

Note 2: Not more than one output should be shorted at a time, and the duration should not exceed one second.

Note 3: I_{CC} is measured with all inputs grounded and all outputs open.

Note 4: T_A = 25°C and V_{CC} = 5V.



'LS190 and 'LS191 Switching Characteristics

at $V_{CC} = 5V$ and $T_A = 25^\circ C$ (See Section 1 for Test Waveforms and Output Load)

Symbol	Parameter	From (Input) To (Output)	$R_L = 2\text{ k}\Omega$				Units
			$C_L = 15\text{ pF}$		$C_L = 50\text{ pF}$		
			Min	Max	Min	Max	
f_{MAX}	Maximum Clock Frequency		20		20		MHz
t_{PLH}	Propagation Delay Time Low to High Level Output	Load to Any Q		33		43	ns
t_{PHL}	Propagation Delay Time High to Low Level Output	Load to Any Q		50		59	ns
t_{PLH}	Propagation Delay Time Low to High Level Output	Data to Any Q		22		26	ns
t_{PHL}	Propagation Delay Time High to Low Level Output	Data to Any Q		50		62	ns
t_{PLH}	Propagation Delay Time Low to High Level Output	Clock to Ripple Clock		20		24	ns
t_{PHL}	Propagation Delay Time High to Low Level Output	Clock to Ripple Clock		24		33	ns
t_{PLH}	Propagation Delay Time Low to High Level Output	Clock to Any Q		24		29	ns
t_{PHL}	Propagation Delay Time High to Low Level Output	Clock to Any Q		36		45	ns
t_{PLH}	Propagation Delay Time Low to High Level Output	Clock to Max/Min		42		47	ns
t_{PHL}	Propagation Delay Time High to Low Level Output	Clock to Max/Min		52		65	ns
t_{PLH}	Propagation Delay Time Low to High Level Output	Up/Down to Ripple Clock		45		50	ns
t_{PHL}	Propagation Delay Time High to Low Level Output	Up/Down to Ripple Clock		45		54	ns
t_{PLH}	Propagation Delay Time Low to High Level Output	Down/Up to Max/Min		33		36	ns
t_{PHL}	Propagation Delay Time High to Low Level Output	Down/Up to Max/Min		33		42	ns
t_{PLH}	Propagation Delay Time Low to High Level Output	Enable to Ripple Clock		33		36	ns
t_{PHL}	Propagation Delay Time High to Low Level Output	Enable to Ripple Clock		33		42	ns



Logic Diagrams

LS190 Decade Counters

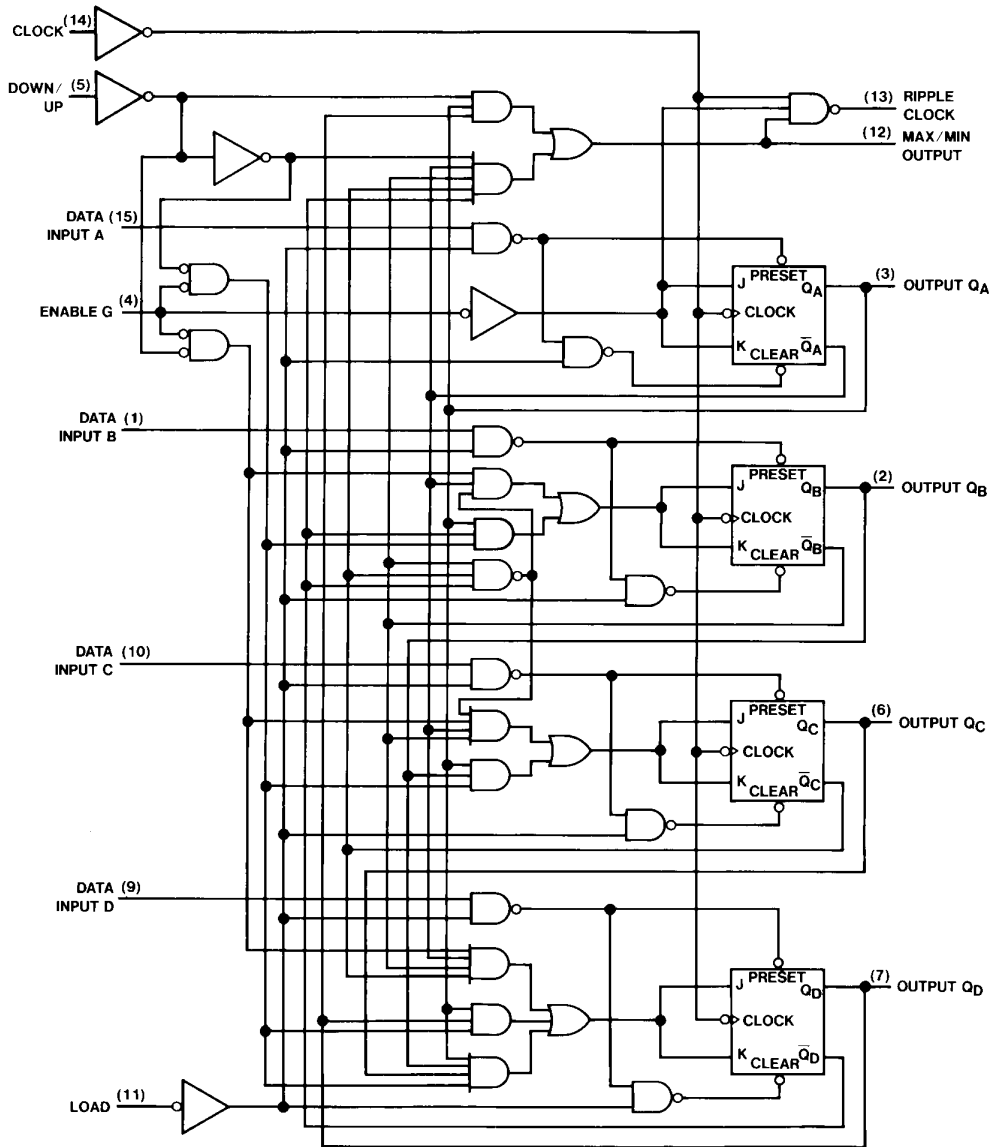

Pin (16) = V_{CC}, Pin (8) = GND

TL/F/6405-2



Logic Diagrams (Continued)

LS191 Binary Counters

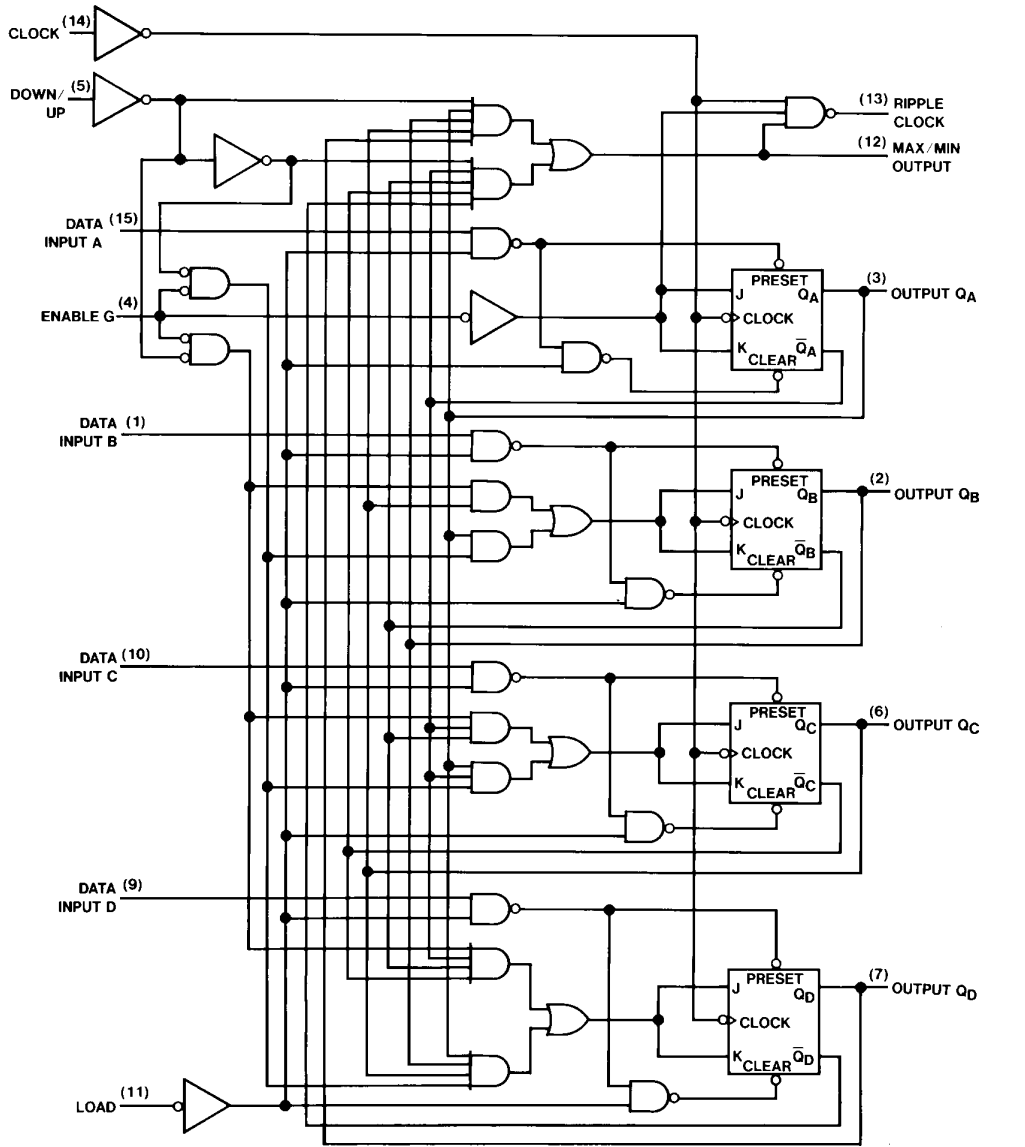

TL/F/6405-3

Pin (16) = V_{CC}, Pin (8) = GND



Timing Diagrams

LS190 Decade Counters
Typical Load, Count, and Inhibit Sequences

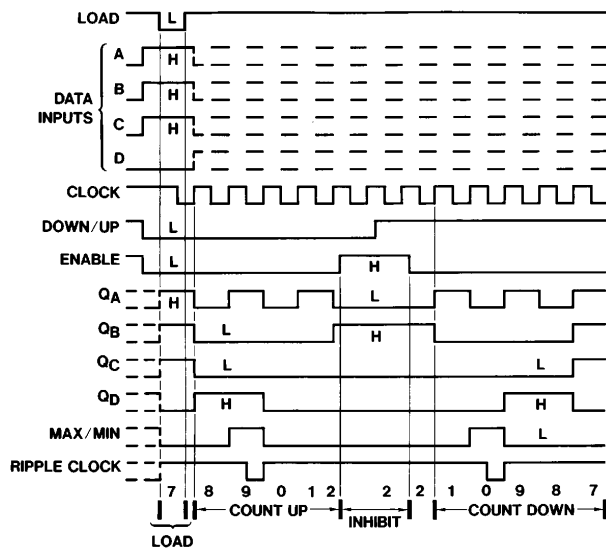

TL/F/6405-4

LS191 Binary Counters
Typical Load, Count, and Inhibit Sequences

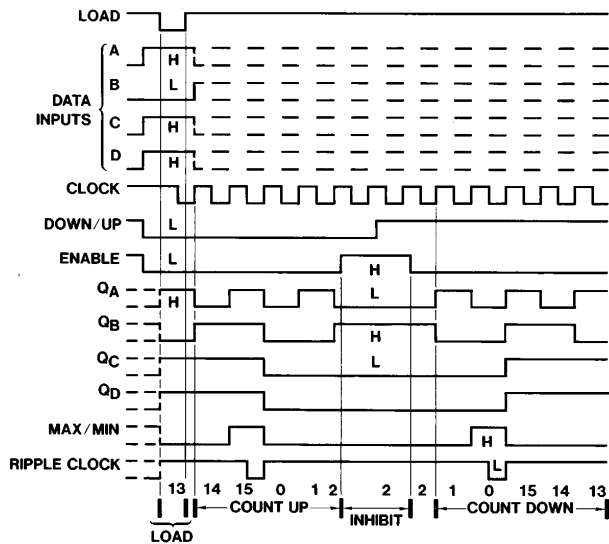

TL/F/6405-5



Physical Dimensions inches (millimeters)

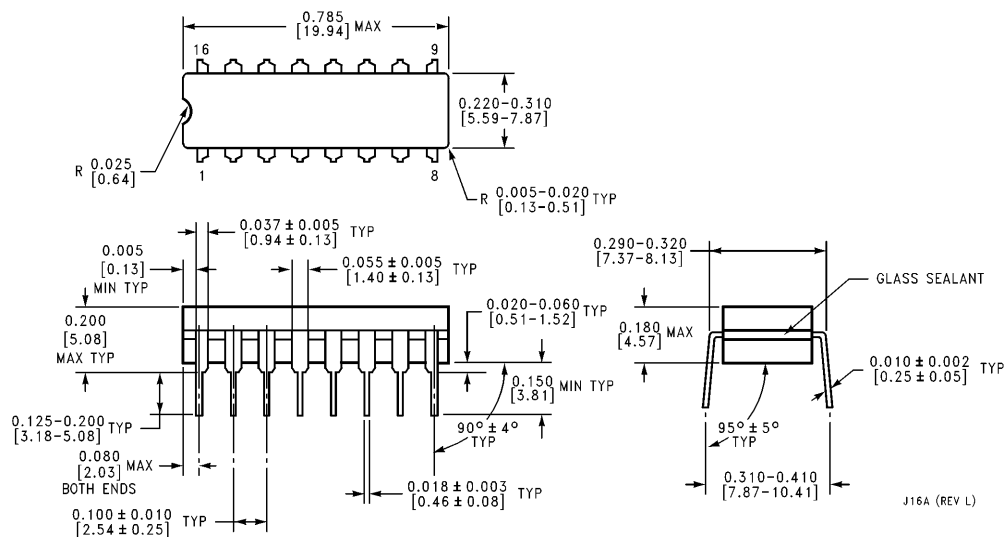

16-Lead Ceramic Dual-In-Line Package (J)
Order Number DM54LS190J, DM54LS191J
NS Package Number J16A

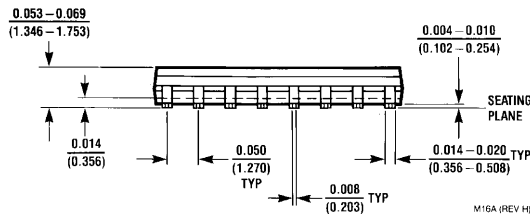
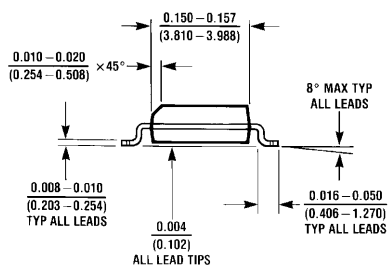
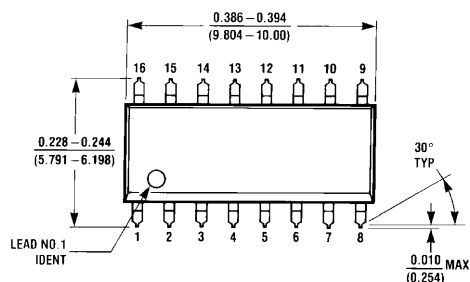

16-Lead Small Outline Molded Package (M)
Order Number DM74LS190M, DM74LS191M
NS Package Number M16A

**DM54LS190/DM74LS190, DM54LS191/DM74LS191
Synchronous 4-Bit Up/Down Counters with Mode Control**

Physical Dimensions inches (millimeters) (Continued)

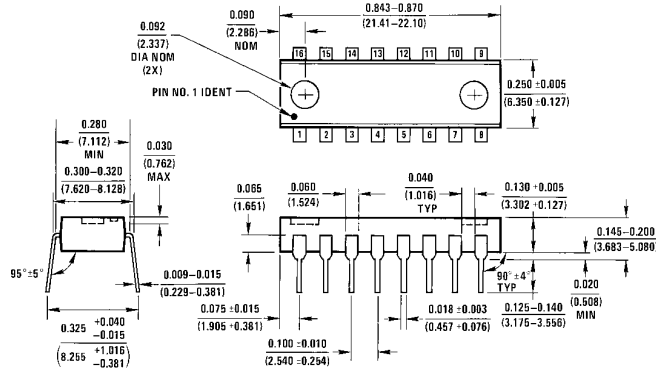

16-Lead Molded Dual-In-Line Package (N)
Order Number DM74LS190N, DM74LS191N
NS Package Number N16E

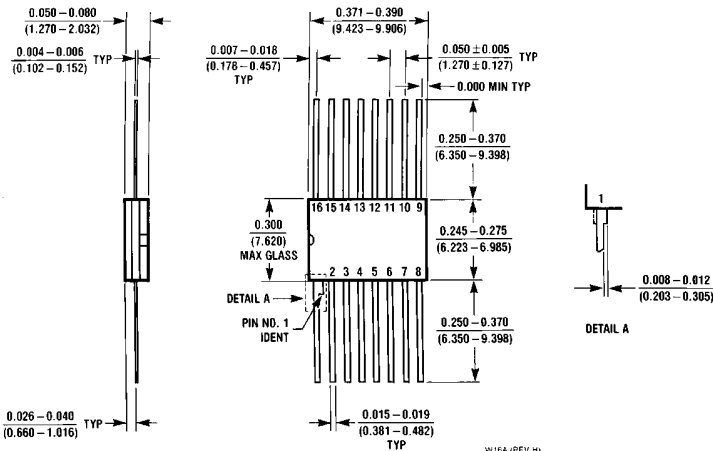

16-Lead Ceramic Flat Package (W)
Order Number DM54LS190W or DM54LS191W
NS Package Number W16A

LIFE SUPPORT POLICY

NATIONAL'S PRODUCTS ARE NOT AUTHORIZED FOR USE AS CRITICAL COMPONENTS IN LIFE SUPPORT DEVICES OR SYSTEMS WITHOUT THE EXPRESS WRITTEN APPROVAL OF THE PRESIDENT OF NATIONAL SEMICONDUCTOR CORPORATION. As used herein:

1. Life support devices or systems are devices or systems which, (a) are intended for surgical implant into the body, or (b) support or sustain life, and whose failure to perform, when properly used in accordance with instructions for use provided in the labeling, can be reasonably expected to result in a significant injury to the user.
2. A critical component is any component of a life support device or system whose failure to perform can be reasonably expected to cause the failure of the life support device or system, or to affect its safety or effectiveness.



National Semiconductor Corporation
1111 West Bardin Road
Arlington, TX 76017
Tel: 1(800) 272-9959
Fax: 1(800) 737-7018

National Semiconductor Europe
Fax: (+49) 0-180-530 85 86
Email: cnjwge@tevm2.nsc.com
Deutsch Tel: (+49) 0-180-530 85 85
English Tel: (+49) 0-180-532 78 32
Français Tel: (+49) 0-180-532 93 58
Italiano Tel: (+49) 0-180-534 16 80

National Semiconductor Hong Kong Ltd.
13th Floor, Straight Block,
Ocean Centre, 5 Canton Rd.
Tsimshatsui, Kowloon
Hong Kong
Tel: (852) 2737-1600
Fax: (852) 2736-9960

National Semiconductor Japan Ltd.
Tel: 81-043-299-2309
Fax: 81-043-299-2408