

1048576 BY 8-BIT BY 2-BANK SYNCHRONOUS DYNAMIC RANDOM-ACCESS MEMORY

SMOS687A – JULY 1996 – REVISED APRIL 1997

- Organization . . . 1M × 8 × 2 Banks
- 3.3-V Power Supply (±10% Tolerance)
- Two Banks for On-Chip Interleaving (Gapless Accesses)
- High Bandwidth – Up to 83-MHz Data Rates
- CAS Latency Programmable to 2 or 3 Cycles From Column-Address Entry
- Burst Sequence Programmable to Serial or Interleave
- Burst Length Programmable to 1, 2, 4, or 8
- Chip Select and Clock Enable for Enhanced-System Interfacing
- Cycle-by-Cycle DQ-Bus Mask Capability
- Auto-Refresh and Self-Refresh Capability
- 4K Refresh (Total for Both Banks)
- High-Speed, Low-Noise Low-Voltage TTL (LVTTTL) Interface
- Power-Down Mode
- Compatible With JEDEC Standards
- Pipeline Architecture
- Temperature Ranges
Operating, 0°C to 70°C
Storage, –55°C to 150°C
- Performance Ranges:

DGE PACKAGE
(TOP VIEW)

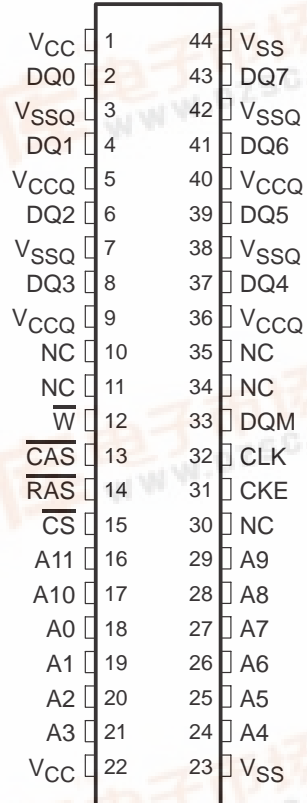

	SYNCHRONOUS CLOCK CYCLE TIME		ACCESS TIME CLOCK TO OUTPUT		REFRESH INTERVAL
	t _{CK3} (CL = 3)	t _{CK2} (CL = 2)	t _{CK3} (CL = 3)	t _{CK2} (CL = 2)	

'626812-12A†	12 ns	15 ns	9 ns	9 ns	64 ms
'626812-12	12 ns	18 ns	9 ns	10 ns	64 ms

†–12A speed device is supported only at –5/+10% V_{CC}

description

The TMS626812 is a high-speed 16777216-bit synchronous dynamic random access memory (SDRAM) device organized as two banks of 1 048 576 words with eight bits per word.

All inputs and outputs of the TMS626812 series are compatible with the LVTTTL interface.

PIN NOMENCLATURE

A0–A10	Address Inputs
A0–A10	Row Addresses
A0–A8	Column Addresses
A10	Automatic-Precharge Select
A11	Bank Select
\overline{CAS}	Column-Address Strobe
CKE	Clock Enable
CLK	System Clock
\overline{CS}	Chip Select
DQ0–DQ7	SDRAM Data Input/Output
DQM	Data/Output Mask Enable
NC	No External Connect
\overline{RAS}	Row-Address Strobe
V _{CC}	Power Supply (3.3-V Typ)
V _{CCQ}	Power Supply for Output Drivers (3.3-V Typ)
V _{SS}	Ground
V _{SSQ}	Ground for Output Drivers
\overline{W}	Write Enable

Please be aware that an important notice concerning availability, standard warranty, and use in critical applications of Texas Instruments semiconductor products and disclaimers thereto appears at the end of this data sheet.

TMS626812
1048576 BY 8-BIT BY 2-BANK
SYNCHRONOUS DYNAMIC RANDOM-ACCESS MEMORY
 SMOS687A – JULY 1996 – REVISED APRIL 1997

description (continued)

The SDRAM employs state-of-the-art technology for high performance, reliability, and low power. All inputs and outputs are synchronized with the CLK input to simplify system design and enhance use with high-speed microprocessors and caches.

The TMS626812 SDRAM is available in a 400-mil, 44-pin surface-mount TSOP package (DGE suffix).

functional block diagram

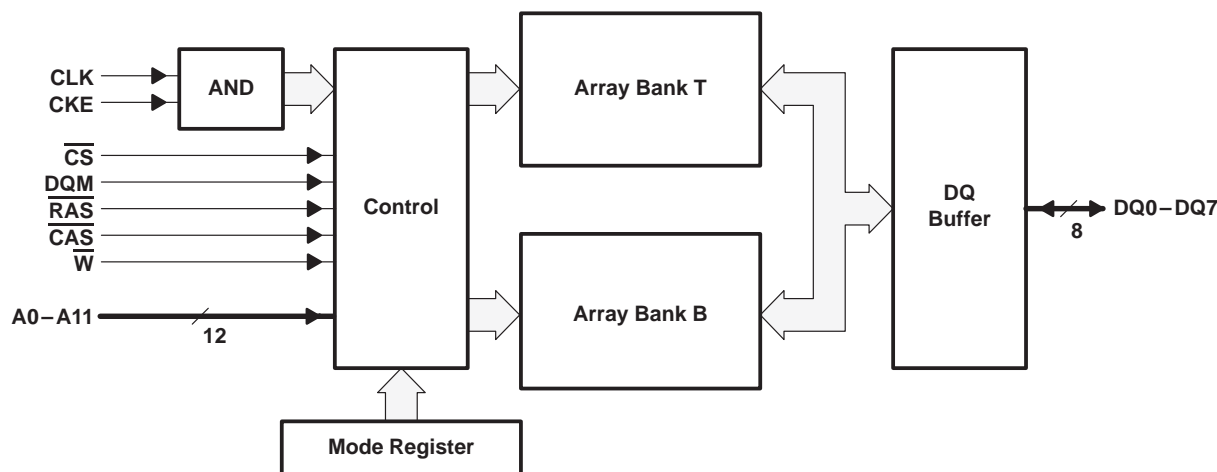

operation

All inputs of the '626812 SDRAM are latched on the rising edge of the system (synchronous) clock. The outputs, DQ0–DQ7, also are referenced to the rising edge of CLK. The '626812 has two banks that are accessed independently. A bank must be activated before it can be accessed (read from or written to). Refresh cycles refresh both banks alternately.

Five basic commands or functions control most operations of the '626812:

- Bank activate/row-address entry
- Column-address entry/write operation
- Column-address entry/read operation
- Bank deactivate
- Auto-refresh
- Self-refresh

Additionally, operations can be controlled by three methods: using chip select (\overline{CS}) to select/deselect the devices, using DQM to enable/mask the DQ signals on a cycle-by-cycle basis, or using CKE to suspend (or gate) the CLK input. The device contains a mode register that must be programmed for proper operation.

Table 1 through Table 3 show the various operations that are available on the '626812. These truth tables identify the command and/or operations and their respective mnemonics. Each truth table is followed by a legend that explains the abbreviated symbols. An access operation refers to any read or write command in progress at cycle n. Access operations include the cycle upon which the read or write command is entered and all subsequent cycles through the completion of the access burst.



operation (continued)

Table 1. Basic-Command Truth Table†

COMMAND‡	STATE OF BANK(S)	\overline{CS}	\overline{RAS}	\overline{CAS}	\overline{W}	A11	A10	A9–A0	MNEMONIC
Mode register set	T = deac B = deac	L	L	L	L	X	X	A9 = V A8–A7 = 0 A6–A0 = V	MRS
Bank deactivate (precharge)	X	L	L	H	L	BS	L	X	DEAC
Deactivate all banks	X	L	L	H	L	X	H	X	DCAB
Bank activate/row-address entry	SB = deac	L	L	H	H	BS	V	V	ACTV
Column-address entry/write operation	SB = actv	L	H	L	L	BS	L	V	WRT
Column-address entry/write operation with automatic deactivate	SB = actv	L	H	L	L	BS	H	V	WRT-P
Column-address entry/read operation	SB = actv	L	H	L	H	BS	L	V	READ
Column-address entry/read operation with automatic deactivate	SB = actv	L	H	L	H	BS	H	V	READ-P
No operation	X	L	H	H	H	X	X	X	NOOP
Control-input inhibit / no operation	X	H	X	X	X	X	X	X	DESL
Auto-refresh§	T = deac B = deac	L	L	L	H	X	X	X	REFR

† For exception of these commands on cycle n:

- CKE(n–1) must be high, or
 - t_{CESP} must be satisfied for power-down exit, or
 - t_{CESP} and t_{RC} must be satisfied for self-refresh exit, or
 - t_{CES} and n_{CLE} must be satisfied for clock-suspend exit.
- DQM(n) is a don't care.

‡ All other unlisted commands are considered vendor-reserved commands or illegal commands.

§ Auto-refresh or self-refresh entry requires that all banks be deactivated or in an idle state prior to the command entry.

Legend:

- n = CLK cycle number
- L = Logic low
- H = Logic high
- X = Don't care, either logic low or logic high
- V = Valid
- T = Bank T
- B = Bank B
- actv = Activated
- deac = Deactivated
- BS = Logic high to select bank T; logic low to select bank B
- SB = Bank selected by A11 at cycle n



TMS626812
1048576 BY 8-BIT BY 2-BANK
SYNCHRONOUS DYNAMIC RANDOM-ACCESS MEMORY
SMOS687A – JULY 1996 – REVISED APRIL 1997

operation (continued)

Table 2. Clock-Enable (CKE) Command Truth Table†

COMMAND‡	STATE OF BANK(S)	CKE (n-1)	CKE (n)	\overline{CS} (n)	\overline{RAS} (n)	\overline{CAS} (n)	\overline{W} (n)	MNEMONIC
Self-refresh entry	T = deac B = deac	H	L	L	L	L	H	SLFR
Power-down entry on cycle (n+1)§	T = no access operation¶ B = no access operation¶	H	L	X	X	X	X	PDE
Self-refresh exit	T = self refresh B = self refresh	L	H	L	H	H	H	—
		L	H	H	X	X	X	—
Power-down exit#	T = power down B = power down	L	H	X	X	X	X	—
CLK suspend on cycle (n+1)	T = access operation¶ B = access operation¶	H	L	X	X	X	X	HOLD
CLK suspend exit on cycle (n+1)	T = access operation¶ B = access operation¶	L	H	X	X	X	X	—

† For execution of these commands, A0–A11 (n) and DQM (n) are don't cares.

‡ All other unlisted commands are considered vendor-reserved commands or illegal commands.

§ On cycle n, the device executes the respective command (listed in Table 1). On cycle (n+1), the device enters power-down mode.

¶ A bank is no longer in an access operation one cycle after the last data-out cycle of a read operation, and two cycles after the last data-in cycle of a write operation. Neither the PDE nor the HOLD command is allowed on the cycle immediately following the last data-in cycle of a write operation.

If setup time from CKE high to the next CLK high satisfies tCESP, the device executes the respective command (listed in Table 1). Otherwise, either DESL or NOOP command must be applied before any other command.

Legend:

- n = CLK cycle number
- L = Logic low
- H = Logic high
- X = Don't care, either logic low or logic high
- T = Bank T
- B = Bank B
- deac = Deactivated



operation (continued)

Table 3. Data-Mask (DQM) Command Truth Table†

COMMAND‡	STATE OF BANK(S)	DQM (n)	DATA IN (n)	DATA OUT (n+2)	MNEMONIC
—	T = deac and B = deac	X	N/A	Hi-Z	—
—	T = actv and B = actv (no access operation)§	X	N/A	Hi-Z	—
Data-in enable	T = write or B = write	L	V	N/A	ENBL
Data-in mask	T = write or B = write	H	M	N/A	MASK
Data-out enable	T = read or B = read	L	N/A	V	ENBL
Data-out mask	T = read or B = read	H	N/A	Hi-Z	MASK

† For exception of these commands on cycle n:

- CKE(n-1) must be high, or
 - tCESP must be satisfied for power-down exit, or
 - tCESP and tRC must be satisfied for self-refresh exit, or
 - tCES and nCLE must be satisfied for clock-suspend exit.
- CS(n), RAS(n), CAS(n), W(n), and A0–A11(n) are don't cares.

‡ All other unlisted commands are considered vendor-reserved commands or illegal commands.

§ A bank is no longer in an access operation one cycle after the last data-out cycle of a read operation, and two cycles after the last data-in cycle of a write operation. Neither the PDE nor the HOLD command is allowed on the cycle immediately following the last data-in cycle of a write operation.

Legend:

- n = CLK cycle number
- L = Logic low
- H = Logic high
- X = Don't care, either logic low or logic high
- V = Valid
- M = Masked input data
- N/A = Not applicable
- T = Bank T
- B = Bank B
- actv = Activated
- deac = Deactivated
- write = Activated and accepting data inputs on cycle n
- read = Activated and delivering data outputs on cycle (n + 2)



TMS626812
1048576 BY 8-BIT BY 2-BANK
SYNCHRONOUS DYNAMIC RANDOM-ACCESS MEMORY
SMOS687A –JULY 1996 – REVISED APRIL 1997

burst sequence

All data for the '626812 are written or read in a burst fashion that is, a single starting address is entered into the device and the '626812 internally accesses a sequence of locations based on that starting address. After the first access, some subsequent accesses can be at preceding as well as succeeding column addresses, depending on the starting address entered. This sequence can be programmed to follow either a serial burst or an interleave burst (see Table 4 through Table 6). The length of the burst can be programmed to be 1, 2, 4, or 8 accesses (see the section on setting the mode register, page 9). After a read burst is complete (as determined by the programmed-burst length), the outputs are in the high-impedance state until the next read access is initiated.

Table 4. 2-Bit Burst Sequences

	INTERNAL COLUMN ADDRESS A0			
	DECIMAL		BINARY	
	START	2ND	START	2ND
Serial	0	1	0	1
	1	0	1	0
Interleave	0	1	0	1
	1	0	1	0

Table 5. 4-Bit Burst Sequences

	INTERNAL COLUMN ADDRESS A1 – A0							
	DECIMAL				BINARY			
	START	2ND	3RD	4TH	START	2ND	3RD	4TH
Serial	0	1	2	3	00	01	10	11
	1	2	3	0	01	10	11	00
	2	3	0	1	10	11	00	01
	3	0	1	2	11	00	01	10
Interleave	0	1	2	3	00	01	10	11
	1	0	3	2	01	00	11	10
	2	3	0	1	10	11	00	01
	3	2	1	0	11	10	01	00



burst sequence (continued)

Table 6. 8-Bit Burst Sequences

	INTERNAL COLUMN ADDRESS A2–A0															
	DECIMAL								BINARY							
	START	2ND	3RD	4TH	5TH	6TH	7TH	8TH	START	2ND	3RD	4TH	5TH	6TH	7TH	8TH
Serial	0	1	2	3	4	5	6	7	000	001	010	011	100	101	110	111
	1	2	3	4	5	6	7	0	001	010	011	100	101	110	111	000
	2	3	4	5	6	7	0	1	010	011	100	101	110	111	000	001
	3	4	5	6	7	0	1	2	011	100	101	110	111	000	001	010
	4	5	6	7	0	1	2	3	100	101	110	111	000	001	010	011
	5	6	7	0	1	2	3	4	101	110	111	000	001	010	011	100
	6	7	0	1	2	3	4	5	110	111	000	001	010	011	100	101
	7	0	1	2	3	4	5	6	111	000	001	010	011	100	101	110
Interleave	0	1	2	3	4	5	6	7	000	001	010	011	100	101	110	111
	1	0	3	2	5	4	7	6	001	000	011	010	101	100	111	110
	2	3	0	1	6	7	4	5	010	011	000	001	110	111	100	101
	3	2	1	0	7	6	5	4	011	010	001	000	111	110	101	100
	4	5	6	7	0	1	2	3	100	101	110	111	000	001	010	011
	5	4	7	6	1	0	3	2	101	100	111	110	001	000	011	010
	6	7	4	5	2	3	0	1	110	111	100	101	010	011	000	001
	7	6	5	4	3	2	1	0	111	110	101	100	011	010	001	000

latency

The beginning data-out cycle of a read burst can be programmed to occur two or three CLK cycles after the read command (see the section on setting the mode register, page 9). This feature allows adjustment of the device so that it operates using the capability to latch the data output from the '626812. The delay between the READ command and the beginning of the output burst is known as CAS latency. After the initial output cycle begins, the data burst occurs at the CLK frequency without any intervening gaps. Use of minimum read latencies is restricted, based on the maximum frequency rating of the '626812.

There is no latency for data-in cycles (write latency). The first data-in cycle of a write burst is entered at the same rising edge of CLK on which the WRT command is entered. The write latency is fixed and is not determined by the mode-register contents.

two-bank operation

The '626812 contains two independent banks that can be accessed individually or in an interleaved fashion. Each bank must be activated with a row address before it can be accessed. Each bank must then be deactivated before it can be activated again with a new row address. The bank-activate/row-address-entry command (ACTV) is entered by holding RAS low, CAS high, \bar{W} high, and A11 valid on the rising edge of CLK. A bank can be deactivated either automatically during a READ-P or a WRT-P command or by use of the deactivate-bank (DEAC) command. Both banks can be deactivated at once by use of the DCAB command (see Table 1 and the section on bank deactivation description, page 8).



TMS626812

1048576 BY 8-BIT BY 2-BANK

SYNCHRONOUS DYNAMIC RANDOM-ACCESS MEMORY

SMOS687A – JULY 1996 – REVISED APRIL 1997

two-bank row-access operation

The two-bank feature allows access of information on random rows at a higher rate of operation than is possible with a standard DRAM by activating one bank with a row address and, while the data stream is being accessed to/from that bank, activating the second bank with another row address. When the data stream to or from the first bank is completed, the data stream to or from the second bank can begin without interruption. After the second bank is activated, the first bank can be deactivated to allow the entry of a new row address for the next round of accesses. In this manner, operation can continue in an interleaved fashion. Figure 24 shows an example of two-bank row-interleaving read bursts with automatic deactivate for a CAS latency of 3 and burst length of 8.

two-bank column-access operation

The availability of two banks allows the access of data from random starting columns between banks at a higher rate of operation. After activating each bank with a row address (ACTV command), A11 can be used to alternate READ or WRT commands between the banks to provide gapless accesses at the CLK frequency, provided all specified timing requirements are met. Figure 25 is an example of two-bank column interleaving read bursts for a CAS latency of three and burst length of two.

bank deactivation (precharge)

Both banks can be simultaneously deactivated (placed in precharge) by using the DCAB command. A single bank can be deactivated by using the DEAC command. The DEAC command is entered identically to the DCAB command except that A10 must be low and A11 used to select the bank to be precharged as shown in Table 1. A bank can also be deactivated automatically by using A10 during a read or write command. If A10 is held high during the entry of a read or write command, the accessed bank (selected by A11) is automatically deactivated upon completion of the access burst. If A10 is held low during the entry of a read or write command, that bank remains active following the burst. The read and write commands with automatic deactivation are signified as READ-P and WRT-P.

chip select (\overline{CS})

\overline{CS} can be used to select or deselect the '626812 for command entry, which might be required for multiple memory-device decoding. If \overline{CS} is held high on the rising edge of CLK (DESL command), the device does not respond to \overline{RAS} , \overline{CAS} , or \overline{W} until the device is selected again by holding \overline{CS} low on the rising edge of CLK. Any other valid command can be entered simultaneously on the same rising CLK edge of the select operation. The device can be selected/deselected on a cycle-by-cycle basis (see Table 1 and Table 2). The use of \overline{CS} does not affect an access burst that is in progress; the DESL command can restrict only \overline{RAS} , \overline{CAS} , and \overline{W} inputs to the '626812.

data mask

The MASK command or its opposite, the data-in enable (ENBL) command (see Table 3), is performed on a cycle-by-cycle basis to gate any data cycle within a read burst or a write burst. The application of DQM to a write burst has no latency ($n_{DID} = 0$ cycle), but the application of DQM to a read burst has a latency of $n_{DOD} = 2$ cycles. During a write burst, if DQM is held high on the rising edge of CLK, the data input is ignored on that cycle. During a read burst, if DQM is held high on the rising edge of CLK, then n_{DOD} cycles after that rising edge of CLK, the data output is in the high-impedance state. Figure 16 and Figure 28 show examples of data-mask operations.

CLK suspend/power-down mode

For normal device operation, CKE should be held high to enable CLK. If CKE goes low during the execution of a READ (READ-P) or WRT (WRT-P) operation, the state of the DQ bus at the immediate next rising edge of CLK is frozen at its current state, and no further inputs are accepted until CKE returns high. This is known



CLK suspend/power-down mode (continued)

as a CLK-suspend operation and its execution indicates a HOLD command. The device resumes operation from the point when it was placed in suspension, beginning with the second rising edge of CLK after CKE returns high.

If CKE is brought low when no read or write command is in progress, the device enters power-down mode. If both banks are deactivated when power-down mode is entered, power consumption is reduced to the minimum. Power-down mode can be used during row-active or auto-refresh periods to reduce input buffer power. After power-down mode is entered, no further inputs are accepted until CKE returns high. To ensure that data in the device remains valid during the power-down mode, the self-refresh command (SLFR) must be executed concurrently with the power-down entry (PDE) command. When exiting power-down mode, new commands can be entered on the first CLK edge after CKE returns high, provided that the setup time (t_{CESP}) is satisfied. Table 2 shows the command configuration for a CLK suspend/power-down operation. Figure 17, Figure 18, and Figure 31 show an example of the procedure.

setting the mode register

The '626812 contains a mode register that must be programmed with the CAS latency, the burst type, and the burst length. This is accomplished by executing a mode-register set (MRS) command with the information entered on address lines A0–A9. A logic 0 must be entered on A7 and A8, but A10 and A11 are don't-care entries for the '626812. When A9=1, the write-burst length is always 1. When A9=0, the write-burst length is defined by A0–A2. Figure 1 shows the valid combinations for a successful MRS command. Only valid addresses allow the mode register to be changed. If the addresses are not valid, the previous contents of the mode register remain unaffected. The MRS command is executed by holding \overline{RAS} , \overline{CAS} , and \overline{W} low, and the input-mode word valid on A0–A9 on the rising edge of CLK (see Table 1). The MRS command can be executed only when both banks are deactivated.

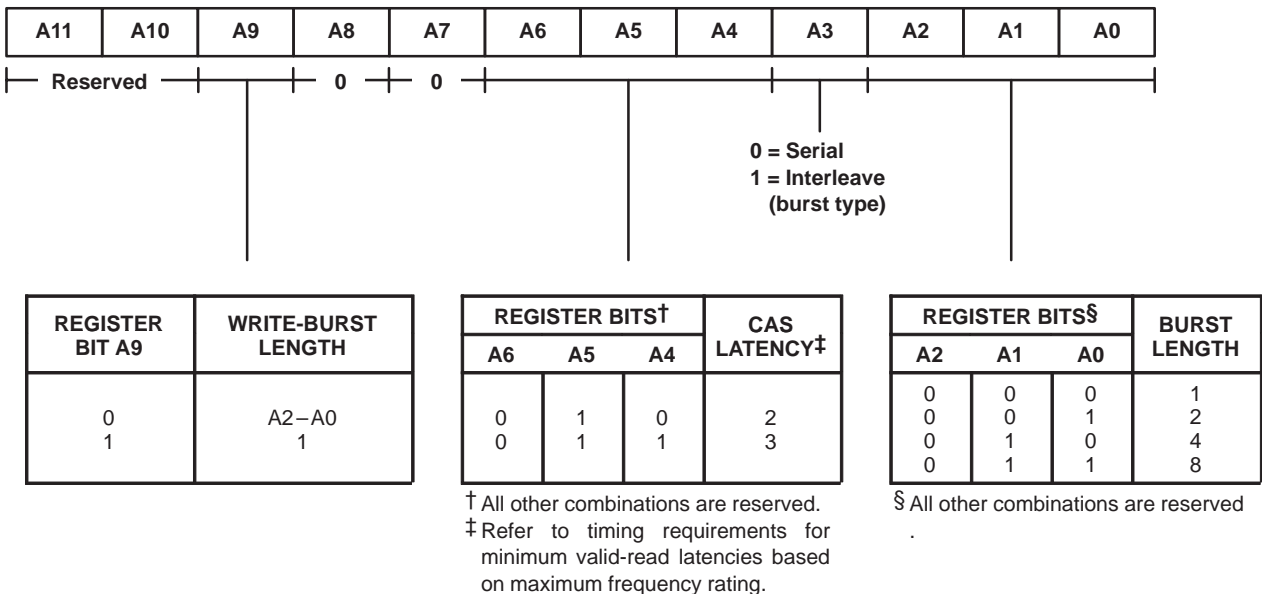

Figure 1. Mode-Register Programming



TMS626812

1048576 BY 8-BIT BY 2-BANK

SYNCHRONOUS DYNAMIC RANDOM-ACCESS MEMORY

SMOS687A – JULY 1996 – REVISED APRIL 1997

refresh

The '626812 must be refreshed at intervals not exceeding t_{REF} (see timing requirements) or data cannot be retained. Refresh can be accomplished by performing a read or write access to every row in both banks, by performing 4096 auto-refresh (REFR) commands, or by placing the device in self-refresh mode. Regardless of the method used, refresh must be accomplished before t_{REF} has expired.

Auto-refresh (REFR)

Before performing a REFR, both banks must be deactivated (placed in precharge). To enter a REFR command, \overline{RAS} and \overline{CAS} must be low and \overline{W} must be high upon the rising edge of CLK (see Table 1). The refresh address is generated internally such that after 4096 REFR commands, both banks of the '626812 have been refreshed. The external address and bank select (A11) are ignored. The execution of a REFR command automatically deactivates both banks upon completion of the internal auto-refresh cycle allowing consecutive REFR-only commands to be executed, if desired, without any intervening DEAC commands. The REFR commands do not necessarily have to be consecutive, but all 4096 must be completed before t_{REF} expires.

self refresh (SLFR)

To enter self refresh, both banks of the '626812 first must be deactivated and a SLFR command must be executed (see Table 2). The SLFR command is identical to the REFR command except that CKE is low. For proper entry of the SLFR command, CKE is brought low for the same rising edge of CLK that \overline{RAS} and \overline{CAS} are low and \overline{W} is high. CKE must be held low to stay in self-refresh mode. In the self-refresh mode, all refreshing signals are generated internally for both banks with all external signals (except CKE) being ignored. Data is retained by the device automatically for an indefinite period when power is maintained and power consumption is reduced to a minimum. To exit self-refresh mode, CKE must be brought high. New commands are issued after t_{RC} has expired. If CLK is made inactive during self refresh, it must be returned to an active and stable condition before CKE is brought high to exit self refresh (see Figure 19).

Upon exiting self refresh, the device must begin the normal refresh scheme immediately. If the burst-refresh scheme is used, 4096 REFR commands must be executed before continuing with normal device operations. If a distributed-refresh scheme utilizing auto-refresh is used (for example, two rows every 32 μ s), the first set of refreshes must be performed before continuing with normal device operation. This ensures that the SDRAM is fully refreshed.

interrupted bursts

A read burst or write burst can be interrupted before the burst sequence has been completed with no adverse effects to the operation. This is accomplished by entering certain superseding commands as listed in Table 7 and Table 8, provided that all timing requirements are met. A DEAC command is considered an interrupt only if it is issued to the same bank as the preceding READ or WRT command. The interruption of READ-P or WRT-P operations is not supported.



interrupted bursts (continued)

Table 7. Read-Burst Interruption

INTERRUPTING COMMAND	EFFECT OR NOTE ON USE DURING READ BURST
READ, READ-P	Current output cycles continue until the programmed latency from the superseding READ (READ-P) command is met and new output cycles begin (see Figure 2).
WRT, WRT-P	The WRT (WRT-P) command immediately supersedes the read burst in progress. To avoid data contention, DQM must be high before the WRT (WRT-P) command to mask output of the read burst on cycles ($n_{CCD}-1$), n_{CCD} , and ($n_{CCD}+1$) assuming that there is any output on these cycles. (see Figure 3).
DEAC, DCAB	The DQ bus is in the high-impedance state when n_{H2P} cycles are satisfied or when the read burst completes, whichever occurs first (see Figure 4).

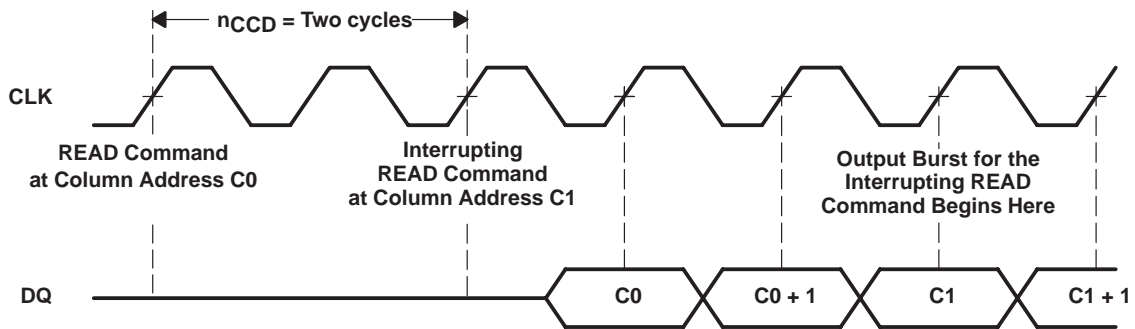
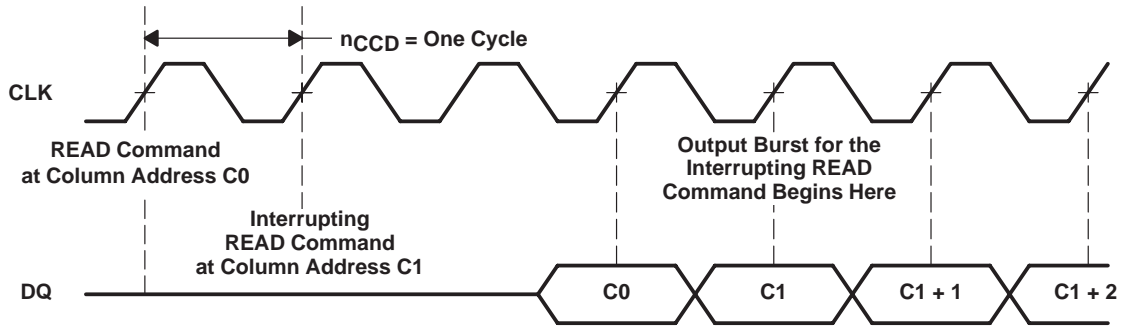

NOTE A: For these examples assume CAS latency = 3, and burst length = 4.

Figure 2. Read Burst Interrupted by Read Command



TMS626812
1048576 BY 8-BIT BY 2-BANK
SYNCHRONOUS DYNAMIC RANDOM-ACCESS MEMORY
 SMOS687A – JULY 1996 – REVISED APRIL 1997

interrupted bursts (continued)

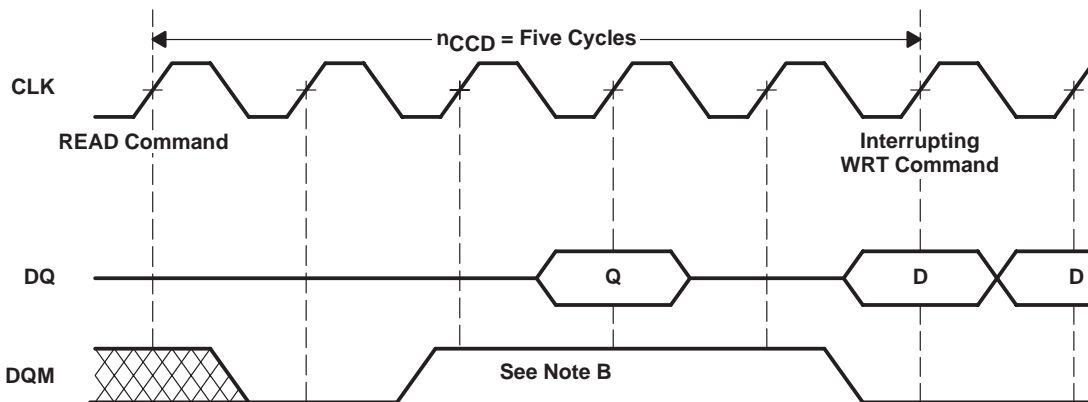

- NOTES: A. For this example, assume CAS latency = 3 and burst length = 4.
 B. DQM must be high to mask output of the read burst on cycles $(n_{CCD} - 1)$, n_{CCD} , and $(n_{CCD} + 1)$.

Figure 3. Read Burst Interrupted by Write Command

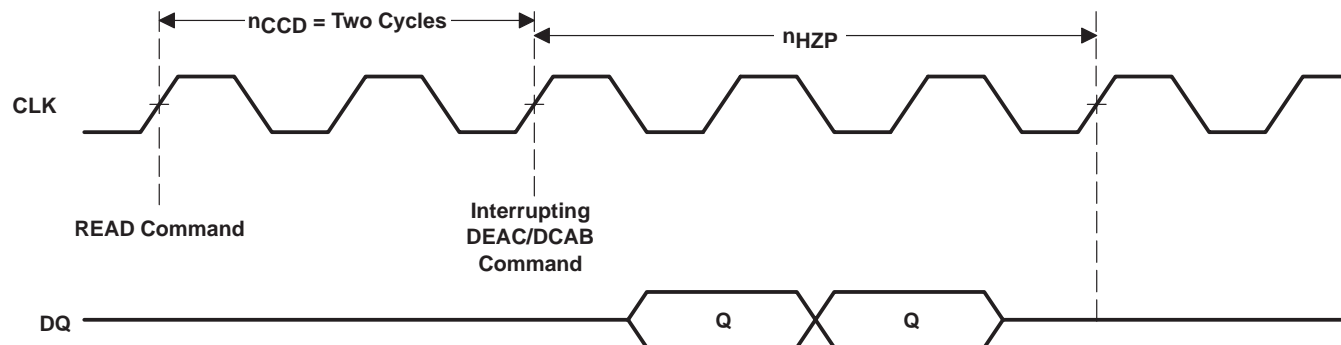

NOTE A: For this example, assume CAS latency = 3 and burst length = 4.

Figure 4. Read Burst Interrupted by DEAC Command



interrupted bursts (continued)

Table 8. Write-Burst Interruption

INTERRUPTING COMMAND	EFFECT OR NOTE ON USE DURING WRITE BURST
READ, READ-P	Data in on the previous cycle is written; however no further data in is accepted (see Figure 5).
WRT, WRT-P	The new WRT (WRT-P) command and data in immediately supersedes the write burst in progress (see Figure 6).
DEAC, DCAB	The DEAC/DCAB command immediately supersedes the write burst in progress. DQM must be used to mask the DQ bus such that the write recovery specification (t_{WR}) is not violated by the interrupt (see Figure 7).

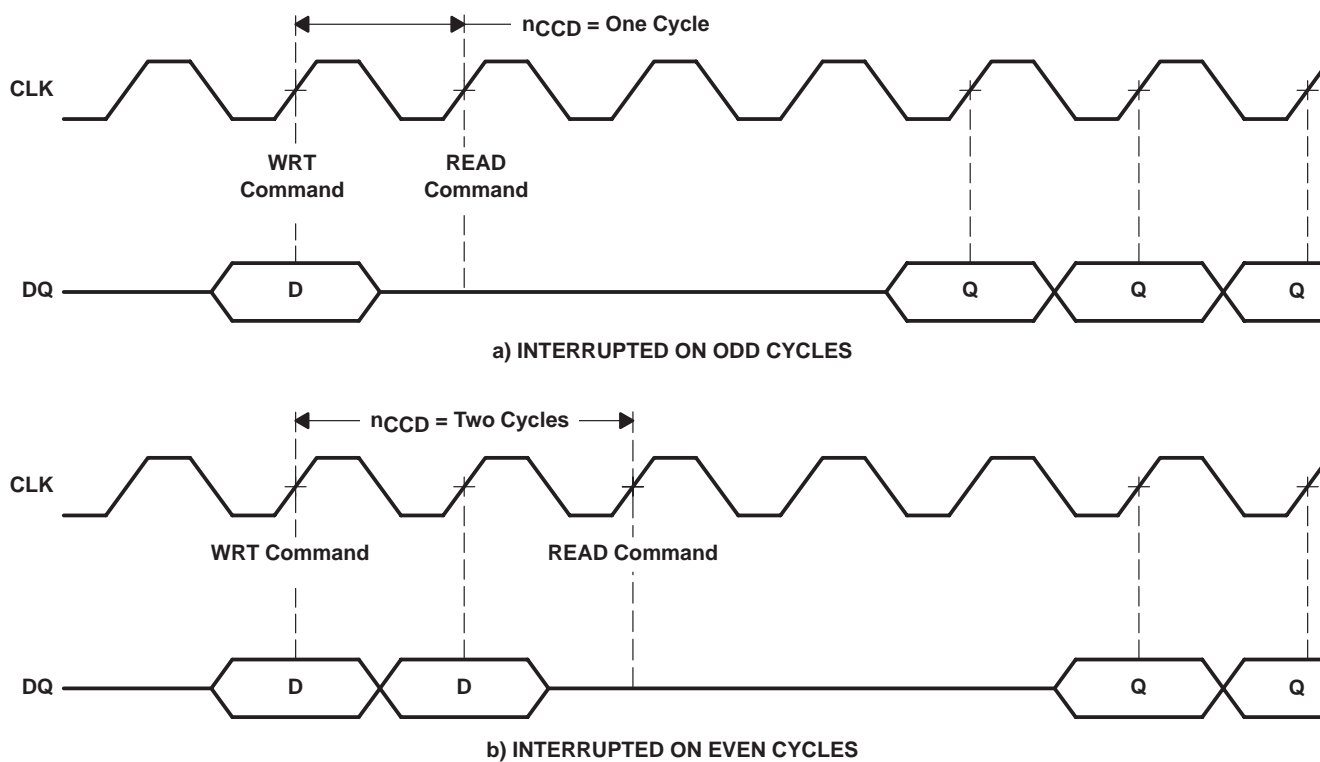

NOTE A: For these examples assume CAS latency = 3, burst length = 4.

Figure 5. Write Burst Interrupted by Read Command



TMS626812
1048576 BY 8-BIT BY 2-BANK
SYNCHRONOUS DYNAMIC RANDOM-ACCESS MEMORY
 SMOS687A – JULY 1996 – REVISED APRIL 1997

interrupted bursts (continued)

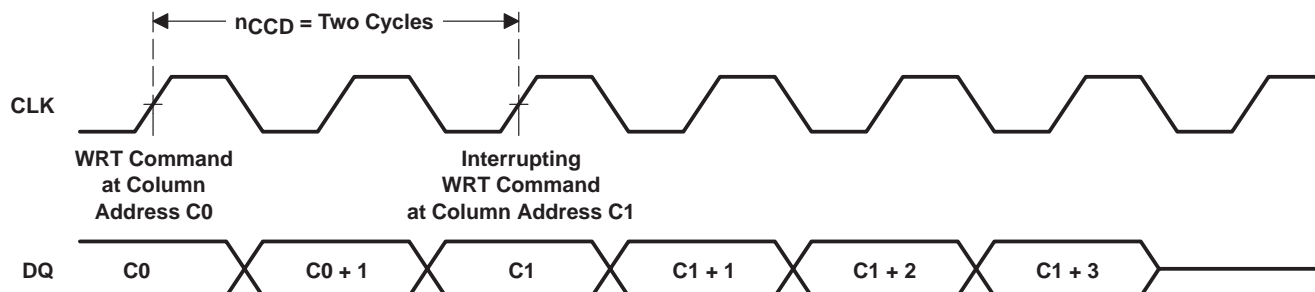

NOTE A: For this example, assume burst length = 4.

Figure 6. Write Burst Interrupted by Write Command

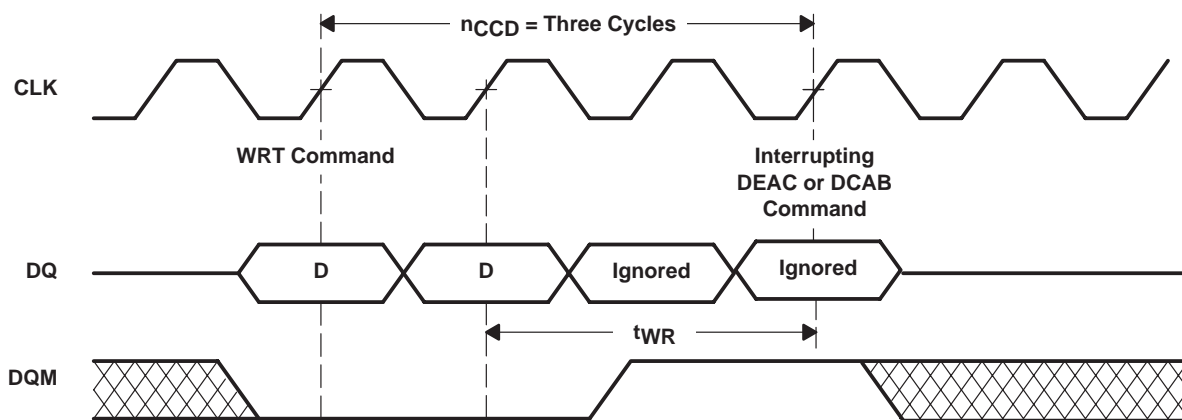

NOTE A: For this example assume burst length = 4.

Figure 7. Write Burst Interrupted by DEAC/DCAB Command

power up

Device initialization should be performed after a power up to the full V_{CC} level. After power is established, a 200- μ s interval is required (with no inputs other than CLK). After this interval, both banks of the device must be deactivated. Eight REFR commands must be performed and the mode register must be set to complete the device initialization.



TMS626812
1048576 BY 8-BIT BY 2-BANK
SYNCHRONOUS DYNAMIC RANDOM-ACCESS MEMORY
SMOS687A – JULY 1996 – REVISED APRIL 1997

absolute maximum ratings over operating free-air temperature range (unless otherwise noted)†

Supply voltage range, V_{CC}	– 0.5 V to 4.6 V
Supply voltage range for output drivers, V_{CCQ}	– 0.5 V to 4.6 V
Voltage range on any pin (see Note 1)	– 0.5 V to 4.6 V
Short-circuit output current	50 mA
Power dissipation	1 W
Operating free-air temperature range, T_A	0°C to 70°C
Storage temperature range, T_{stg}	– 55°C to 150°C

† Stresses beyond those listed under “absolute maximum ratings” may cause permanent damage to the device. These are stress ratings only, and functional operation of the device at these or any other conditions beyond those indicated under “recommended operating conditions” is not implied. Exposure to absolute-maximum-rated conditions for extended periods may affect device reliability.

NOTE 1: All voltage values are with respect to V_{SS} .

recommended operating conditions

	MIN	NOM	MAX	UNIT
V_{CC} Supply voltage	3	3.3	3.6	V
V_{CCQ} Supply voltage for output drivers	3	3.3	3.6	V
V_{SS} Supply voltage		0		V
V_{SSQ} Supply voltage for output drivers		0		V
V_{IH} High-level input voltage	2		$V_{CC} + 0.3$	V
V_{IL} Low-level input voltage (see Note 2)	– 0.3		0.8	V
T_A Operating free-air temperature	0		70	°C

NOTE 2: V_{IL} MIN = –1.5 V AC (pulse width ≤ 5 ns)



TMS626812
 1048576 BY 8-BIT BY 2-BANK
 SYNCHRONOUS DYNAMIC RANDOM-ACCESS MEMORY

SMOS687A – JULY 1996 – REVISED APRIL 1997

electrical characteristics over recommended ranges of supply voltage and free-air temperature (unless otherwise noted) (see Note 3)

PARAMETER	TEST CONDITIONS	'626812-12A		'626812-12		UNIT
		MIN	MAX	MIN	MAX	
V _{OH} High-level output voltage	I _{OH} = -2 mA	2.4		2.4		V
V _{OL} Low-level output voltage	I _{OL} = 2 mA		0.4		0.4	V
I _I Input current (leakage)	0 V ≤ V _I ≤ V _{CC} + 0.3 V, All other pins = 0 V to V _{CC}		±10		±10	µA
I _O Output current (leakage)	0 V ≤ V _O ≤ V _{CC} + 0.3 V, Output disabled		±10		±10	µA
I _{CC1} Operating current	Burst length = 1, t _{RC} ≥ t _{RC} MIN		85		75	mA
	I _{OH} /I _{OL} = 0 mA, 1 bank activated (see Note 4)		95		95	mA
I _{CC2P} Precharge standby current in power down mode	CKE ≤ V _{I_L} MAX, t _{CK} = 15 ns (see Note 5)		2		2	mA
	CKE & CLK ≤ V _{I_L} MAX, t _{CK} = infinity (see Note 6)		2		2	mA
I _{CC2N} Precharge standby current in non-power down mode	CKE ≥ V _{I_H} MIN, t _{CK} = 15 ns (see Note 5)		30		30	mA
	CKE ≥ V _{I_H} MIN, CLK ≤ V _{I_L} MAX, t _{CK} = infinity (see Note 6)		2		2	mA
I _{CC3P} Active standby current in power down mode	CKE ≤ V _{I_L} MAX, t _{CK} = 15 ns (see Note 5)		8		8	mA
	CKE & CLK ≤ V _{I_L} MAX, t _{CK} = infinity (see Note 6)		8		8	mA
I _{CC3N} Active standby current in non-power down mode	CKE ≥ V _{I_H} MIN, t _{CK} = 15 ns (see Note 5)		35		35	mA
	CKE ≥ V _{I_H} MIN, CLK ≤ V _{I_L} MAX, t _{CK} = infinity (see Note 6)		10		10	mA
I _{CC4} Burst current	Page burst, I _{OH} /I _{OL} = 0 mA		130		110	mA
	All banks activated, n _{CCD} = 1 cycle (see Note 7)		155		155	mA
I _{CC5} Auto-refresh current	t _{RC} ≤ t _{RC} MIN		75		70	mA
	CKE ≤ V _{I_L} MAX		85		85	mA
I _{CC6} Self-refresh current	CKE ≤ V _{I_L} MAX		2		2	mA

- NOTES: 3. All specifications apply to the device after power-up initialization. All control and address inputs must be stable and valid.
 4. Control, DQ, and address inputs change state only twice during t_{RC}.
 5. Control, DQ, and address inputs change state only once every 30 ns.
 6. Control, DQ, and address inputs do not change (stable).
 7. Control, DQ, and address inputs change state only once every cycle.

TMS626812
1048576 BY 8-BIT BY 2-BANK
SYNCHRONOUS DYNAMIC RANDOM-ACCESS MEMORY
SMOS687A – JULY 1996 – REVISED APRIL 1997

capacitance over recommended ranges of supply voltage and operating free-air temperature, $f = 1$ MHz (see Note 8)

	MIN	MAX	UNIT
$C_{i(S)}$ Input capacitance, CLK		5	pF
$C_{i(AC)}$ Input capacitance, A0–A11, \overline{CS} , DQM, \overline{RAS} , \overline{CAS} , \overline{W}		5	pF
$C_{i(E)}$ Input capacitance, CKE		5	pF
C_o Output capacitance		8	pF

NOTE 8: $V_{CC} = 3.3 \pm 0.3$ V and bias on pins under test is 0 V.

ac timing requirements over recommended ranges of supply voltage and operating free-air temperature^{†‡}

	'626812-12A§		'626812-12		UNIT
	MIN	MAX	MIN	MAX	
t_{CK2} Cycle time, CLK, CAS latency = 2	15		18		ns
t_{CK3} Cycle time, CLK, CAS latency = 3	12		12		ns
t_{CH} Pulse duration, CLK high	4		4		ns
t_{CL} Pulse duration, CLK low	4		4		ns
t_{AC2} Access time, CLK high to data out, CAS latency = 2 (see Note 9)		9		10	ns
t_{AC3} Access time, CLK high to data out, CAS latency = 2 (see Note 9)		9		9	ns
t_{OH} Hold time, CLK high to data out	3		3		ns
t_{LZ} Delay time, CLK high to DQ in low-impedance state (see Note 10)	3		3		ns
t_{HZ} Delay time, CLK high to DQ in high-impedance state (see Note 11)		10		10	ns
t_{IS} Setup time, address, control, and data input	3		3		ns
t_{IH} Hold time, address, control, and data input	1		1.5		ns
t_{CESP} Power down/self-refresh exit time (see Note 12)	10		10		ns
t_{RAS} Delay time, ACTV command to DEAC or DCAB command	60	100 000	72	100 000	ns
t_{RC} Delay time, ACTV, MRS, REFR, or SLFR to ACTV, MRS, REFR, or SLFR command	90		108		ns
t_{RCD} Delay time, ACTV command to READ, READ-P, WRT, or WRT-P command (see Note 13)	30		30		ns
t_{RP} Delay time, DEAC or DCAB command to ACTV, MRS, REFR, or SLFR command	30		36		ns
t_{RRD} Delay time, ACTV command in one bank to ACTV command in the other bank	24		24		ns
t_{RSA} Delay time, MRS command to ACTV, MRS, REFR, or SLFR command	24		24		ns
t_{APR} Final data out of READ-P operation to ACTV, MRS, SLFR, or REFR command	$t_{RP} - (CL - 1) * t_{CK}$				ns

[†] See Parameter Measurement Information for load circuits.

[‡] All references are made to the rising transition of CLK, unless otherwise noted.

§ –12A speed device is supplied only at $-5\%/+10\%$ V_{CC}

NOTES: 9. t_{AC} is referenced from the rising transition of CLK that is previous to the data-out cycle. For example, the first data out t_{AC} is referenced from the rising transition of CLK0 that is CAS latency – one cycle after the READ command. An access time is measured at output reference level 1.4 V.

10. t_{LZ} is measured from the rising transition of CLK that is CAS latency – one cycle after the READ command.

11. t_{HZ} MAX defines the time at which the outputs are no longer driven and is not referenced to output voltage levels.

12. See Figure 18 and Figure 19

13. For read or write operations with automatic deactivate, t_{RCD} must be set to satisfy minimum t_{RAS} .



TMS626812
1048576 BY 8-BIT BY 2-BANK
SYNCHRONOUS DYNAMIC RANDOM-ACCESS MEMORY
SMOS687A –JULY 1996 – REVISED APRIL 1997

ac timing requirements over recommended ranges of supply voltage and operating free-air temperature (continued)†‡

	'626812-12A		'626812-12		UNIT
	MIN	MAX	MIN	MAX	
t _{APW} Final data in of WRT-P operation to ACTV, MRS, SLFR, or REFR command	60		60		ns
t _{WR} Delay time, final data in of WRT operation to DEAC or DCAB command	15		20		ns
t _T Transition time (see Note 14)	1	5	1	5	ns
t _{REF} Refresh interval		64		64	ms
n _{CCD} Delay time, READ or WRT command to an interrupting command	1		1		cycle
n _{CDD} Delay time, CS low or high to input enabled or inhibited	0	0	0	0	cycle
n _{CLE} Delay time, CKE high or low to CLK enabled or disabled	1	1	1	1	cycle
n _{CWL} Delay time, final data in of WRT operation to READ, READ-P, WRT, WRT-P	1		1		cycle
n _{DID} Delay time, ENBL or MASK command to enabled or masked data in	0	0	0	0	cycle
n _{DOD} Delay time, ENBL or MASK command to enabled or masked data out	2	2	2	2	cycle
n _{HZP2} Delay time, DEAC or DCAB, command to DQ in high-impedance state, CAS latency = 2		2		2	cycle
n _{HZP3} Delay time, DEAC or DCAB, command to DQ in high-impedance state, CAS latency = 3		3		3	cycle
n _{WCD} Delay time, WRT command to first data in	0	0	0	0	cycle

† See Parameter Measurement Information for load circuits.
‡ All references are made to the rising transition of CLK, unless otherwise noted.
NOTE 14: Transition time, t_T, is measured between V_{IH} and V_{IL}.



PARAMETER MEASUREMENT INFORMATION

general information for ac timing measurements

The ac timing measurements are based on signal rise and fall times equal to 1 ns ($t_T = 1$ ns) and a midpoint reference level of 1.4 V for LVTTTL. For signal rise and fall times greater than 1 ns, the reference level should be changed to V_{IH} MIN and V_{IL} MAX instead of the midpoint level. All specifications referring to READ commands are also valid for READ-P commands unless otherwise noted. All specifications referring to WRT commands are also valid for WRT-P commands unless otherwise noted. All specifications referring to consecutive commands are specified as consecutive commands for the same bank unless otherwise noted.

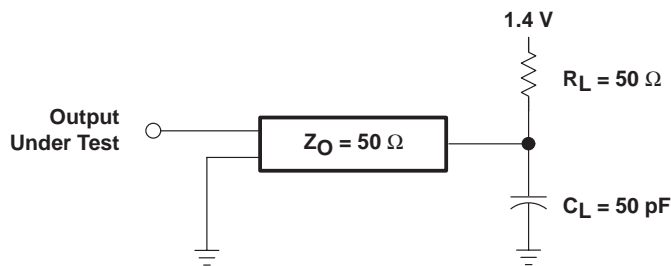

Figure 8. LVTTTL-Load Circuit

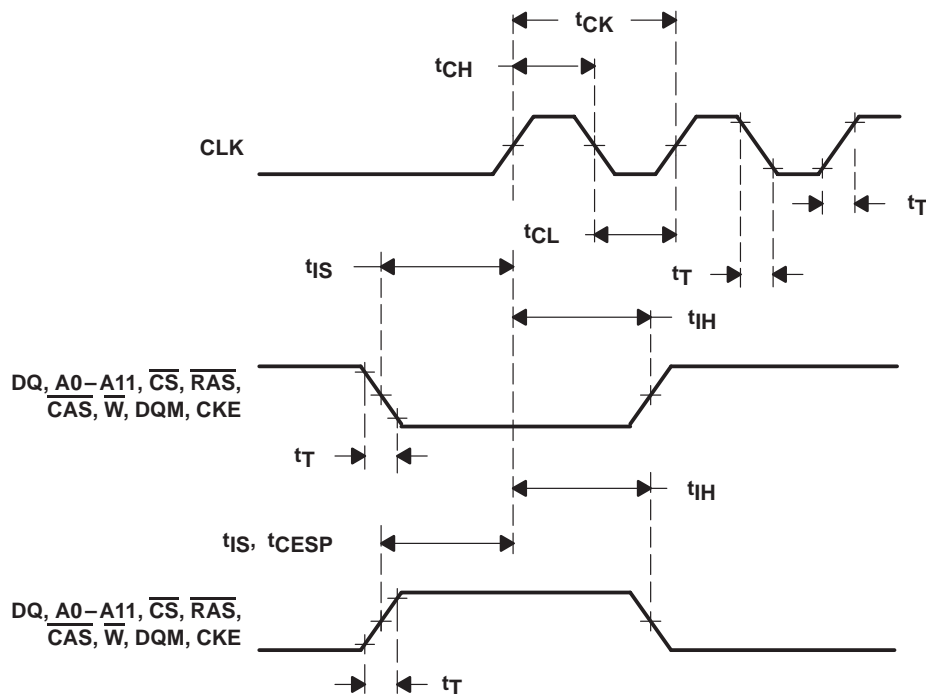

Figure 9. Input-Attribute Parameters



PARAMETER MEASUREMENT INFORMATION

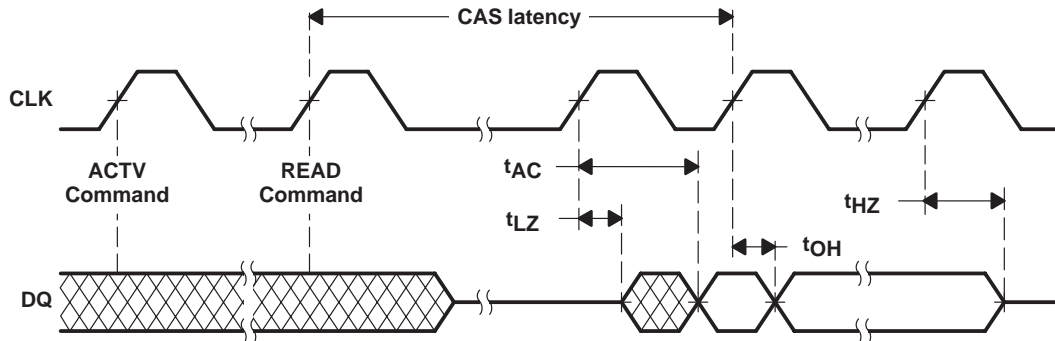

Figure 10. Output Parameters

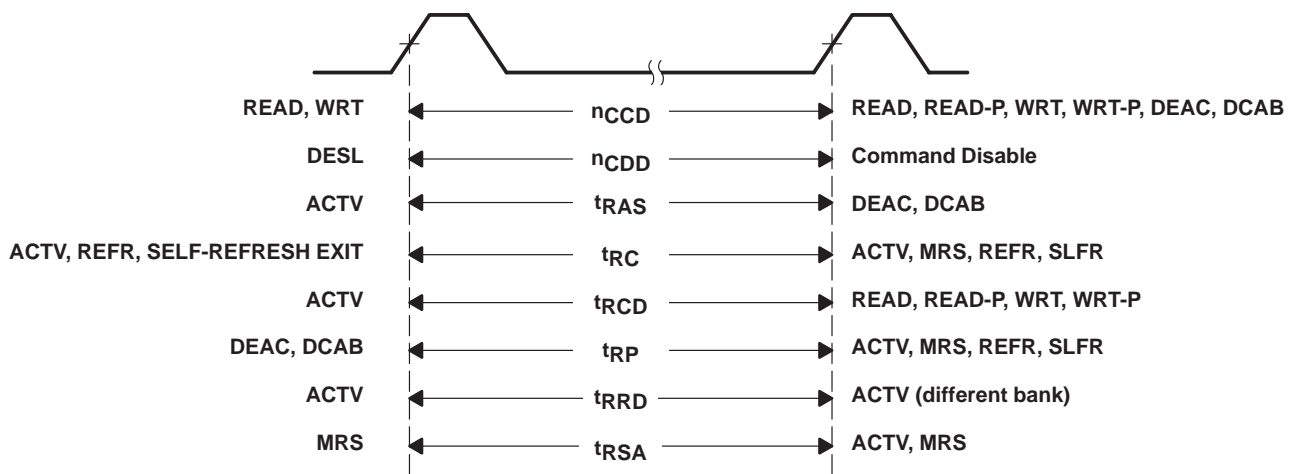
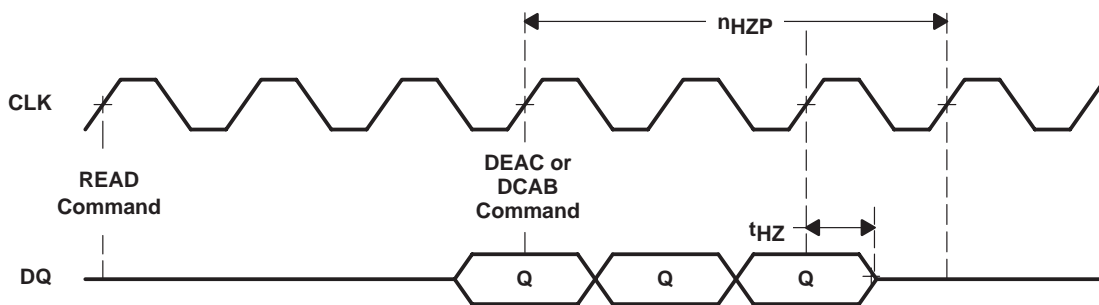

Figure 11. Command-to-Command Parameters



NOTE A: For this example, assume CAS latency = 3, and burst length = 4.

Figure 12. Read Followed by Deactivate



PARAMETER MEASUREMENT INFORMATION

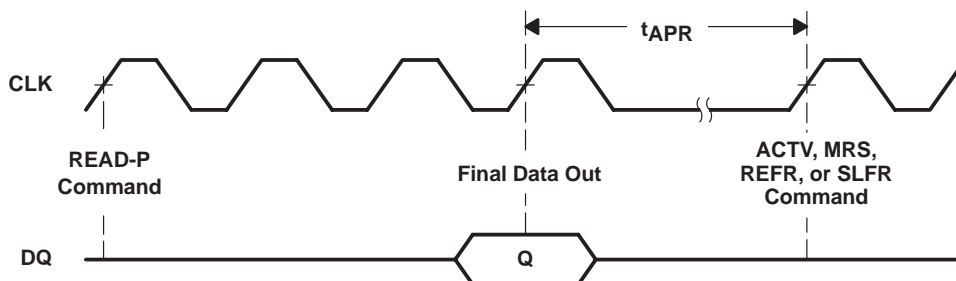

NOTE A: For this example, assume CAS latency = 3, and burst length = 1.

Figure 13. Read With Auto-Deactivate

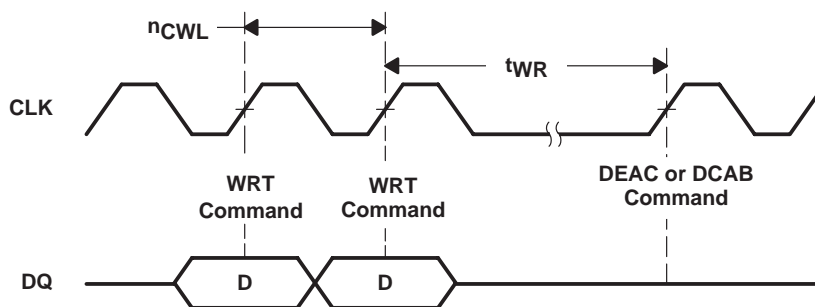

NOTE A: For this example, assume burst length = 1.

Figure 14. Write Followed By Deactivate

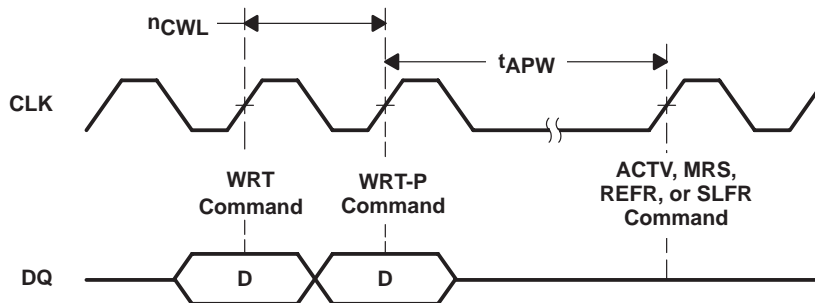
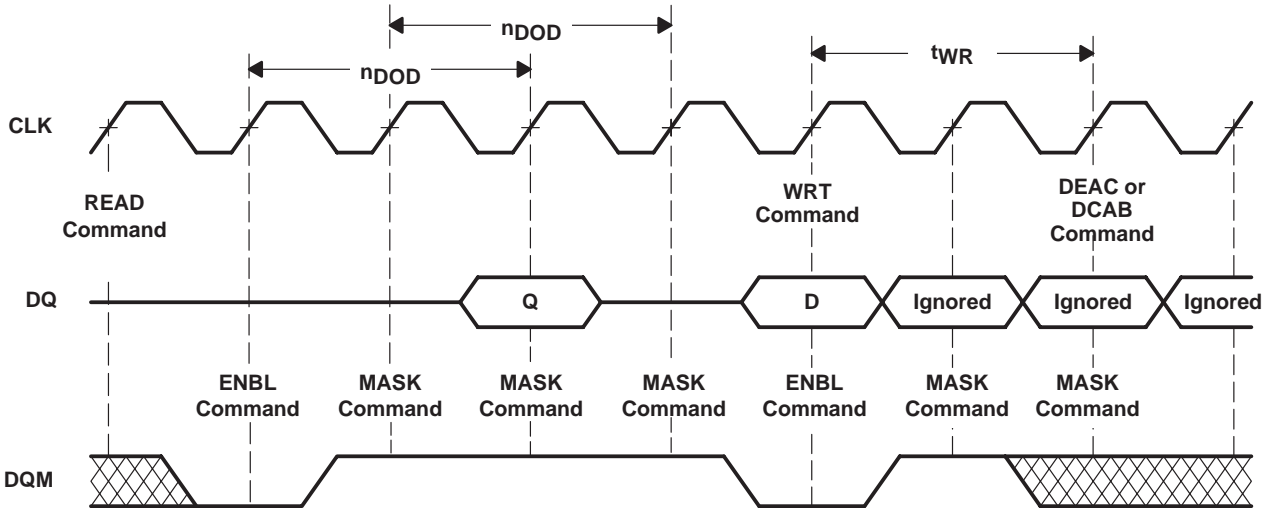

Figure 15. Write With Auto-Deactivate



PARAMETER MEASUREMENT INFORMATION



NOTE A: For this example assume CAS latency = 3, and burst length = 4.

Figure 16. DQ Masking

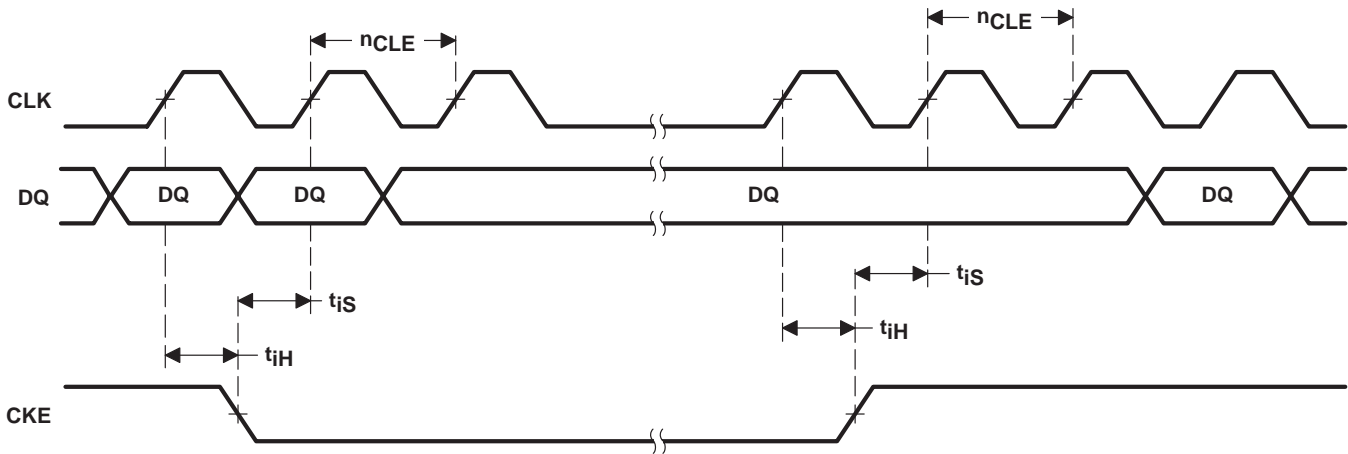

Figure 17. CLK-Suspend Operation



PARAMETER MEASUREMENT INFORMATION

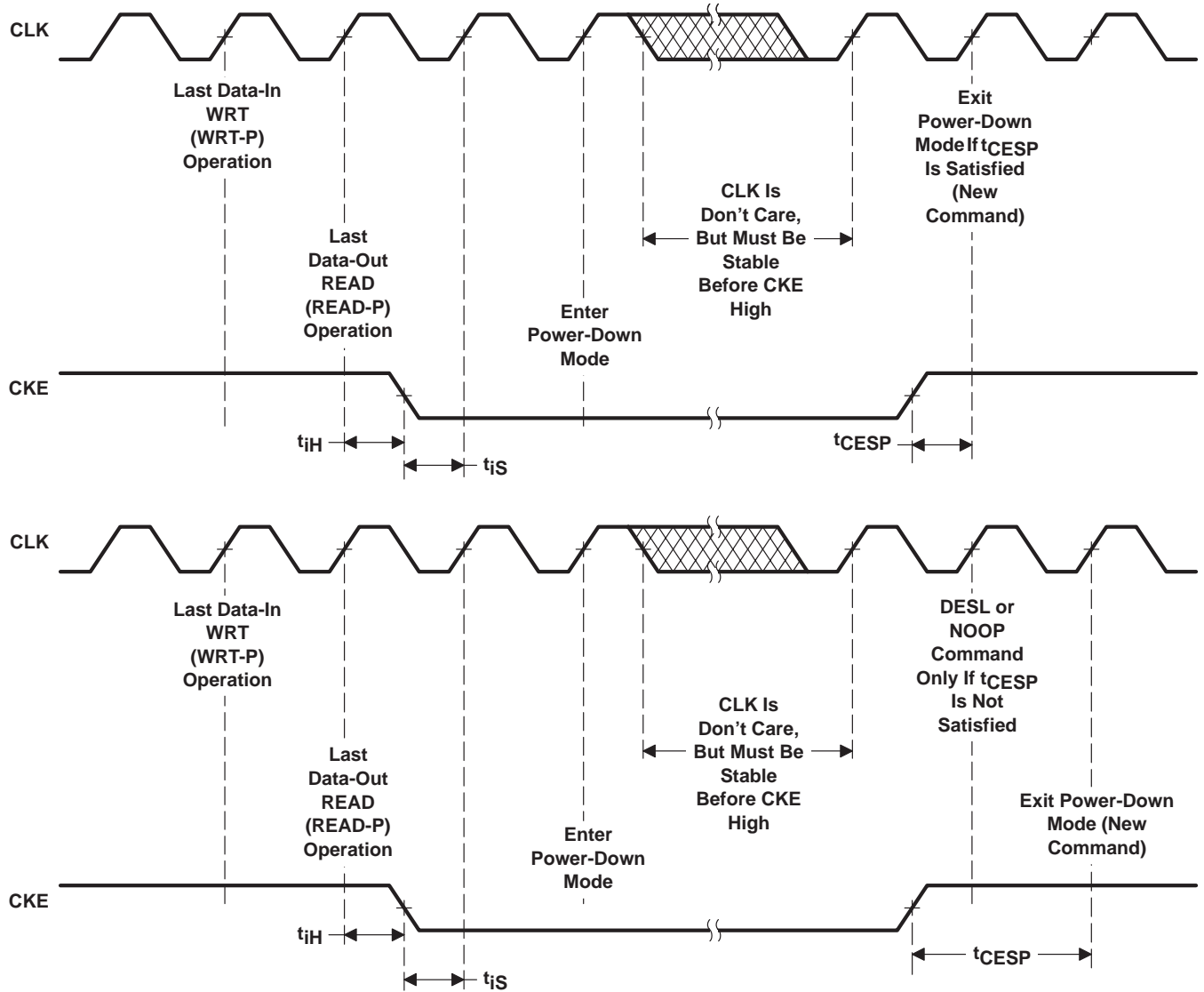

Figure 18. Power-Down Operation



TMS626812
 1048576 BY 8-BIT BY 2-BANK
 SYNCHRONOUS DYNAMIC RANDOM-ACCESS MEMORY
 SMOS687A - JULY 1996 - REVISED APRIL 1997

PARAMETER MEASUREMENT INFORMATION

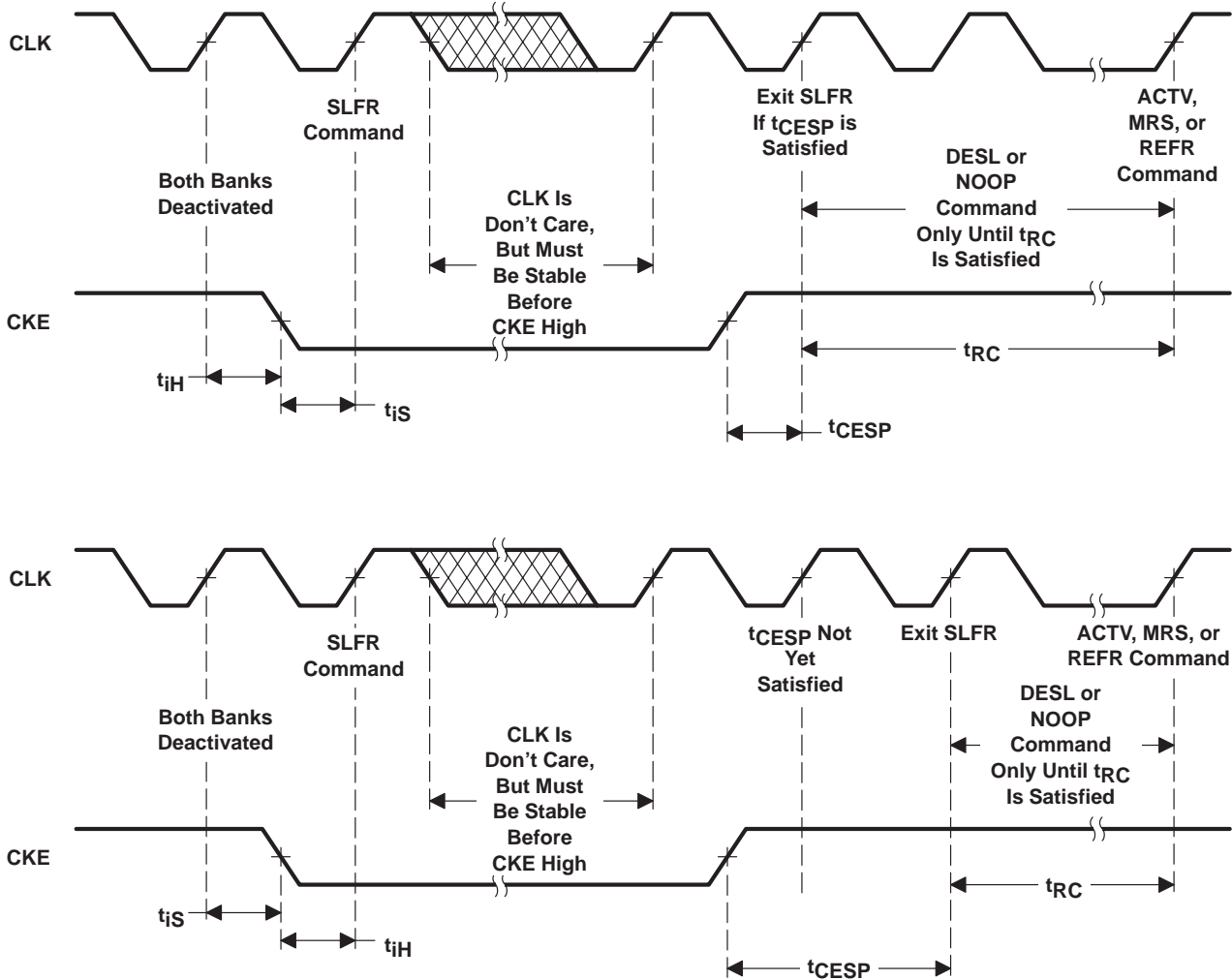
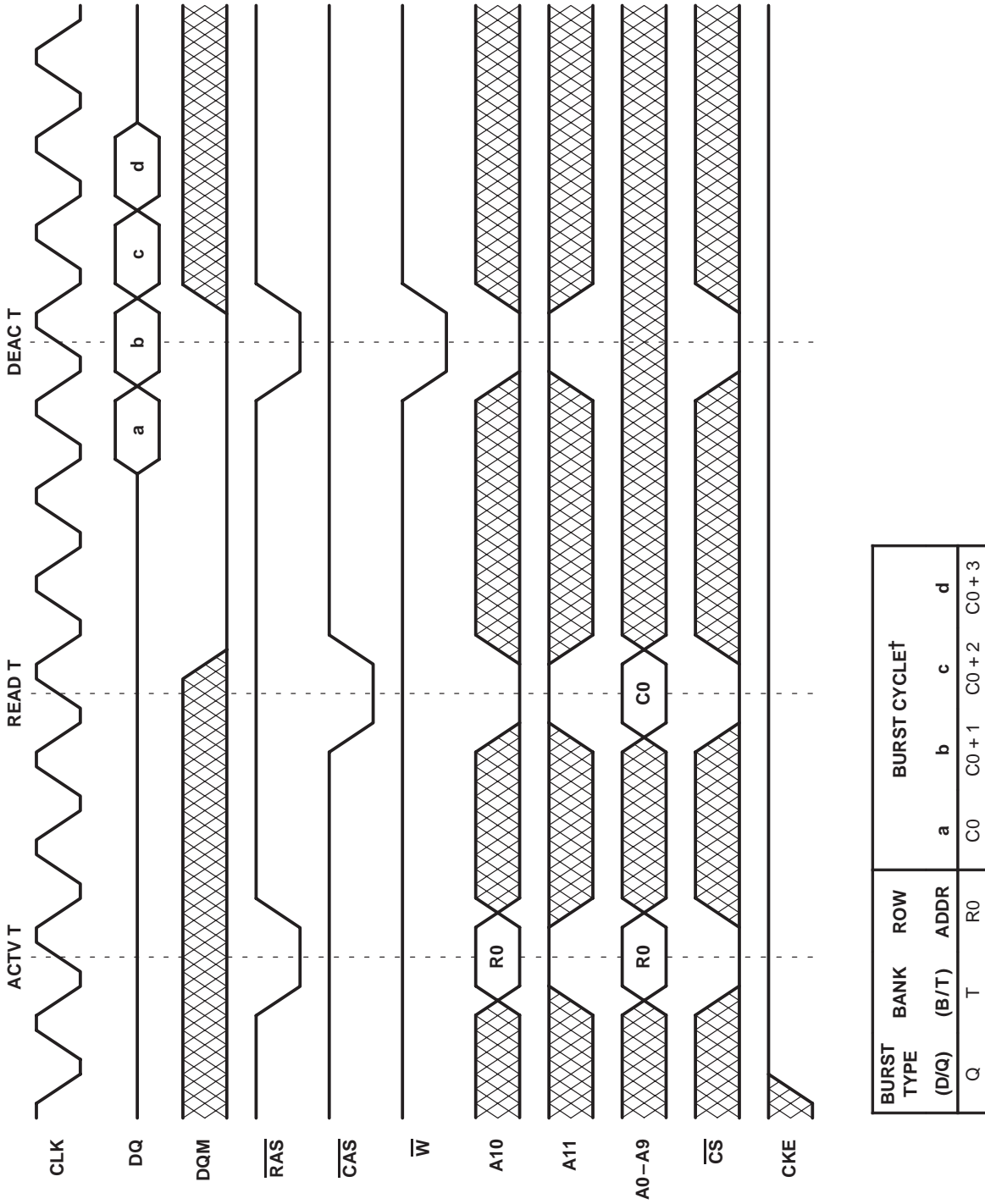

Figure 19. Self-Refresh Operation



PARAMETER MEASUREMENT INFORMATION



† Column-address sequence depends on programmed burst type and starting column address C0 (see Table 5).
 NOTE A: This example illustrates minimum t_{RCD} for the '626812-12 at 83 MHz.

Figure 20. Read Burst (CAS latency = 3, burst length = 4)

PARAMETER MEASUREMENT INFORMATION

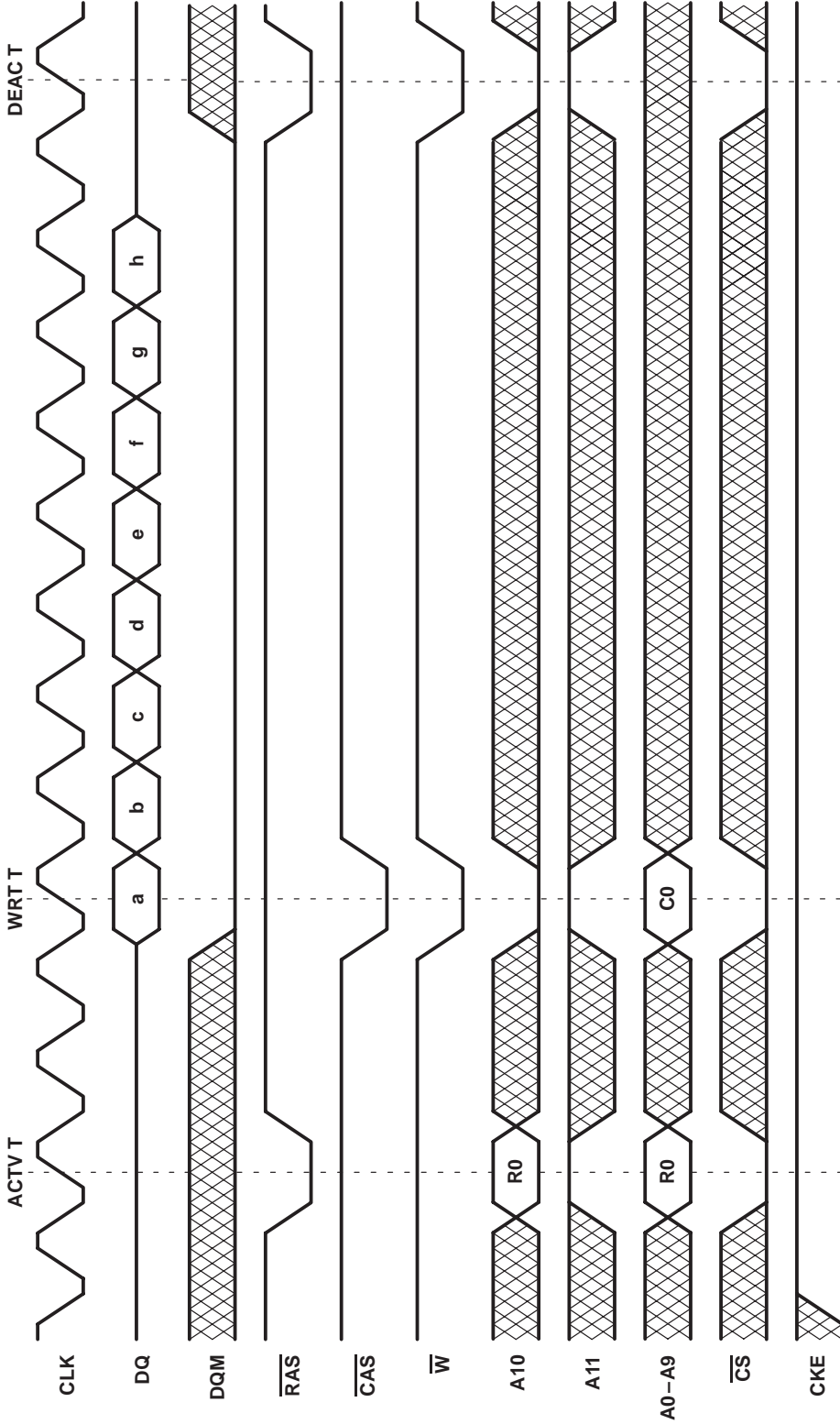

BURST TYPE (D/Q)	BANK (B/T)	ROW ADDR	BURST CYCLE†							
			a	b	c	d	e	f	g	h
D	T	R0	C0	C0+1	C0+2	C0+3	C0+4	C0+5	C0+6	C0+7

† Column-address sequence depends on programmed burst type and starting column address C0 (see Table 6).
 NOTE A: This example illustrates minimum tRCD for the '626812-12 at 83 MHz.

Figure 21. Write Burst (burst length = 8)

PARAMETER MEASUREMENT INFORMATION

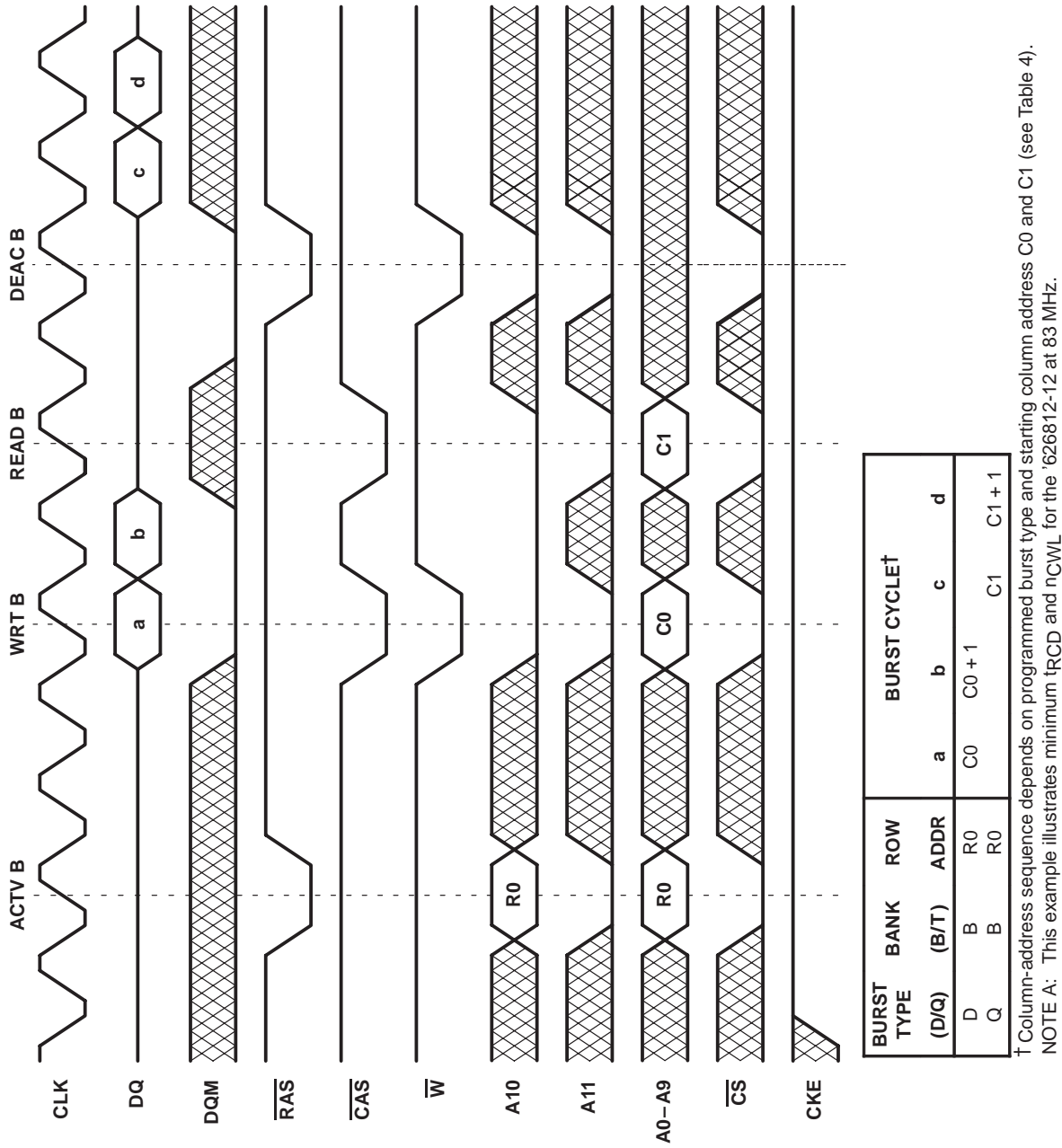
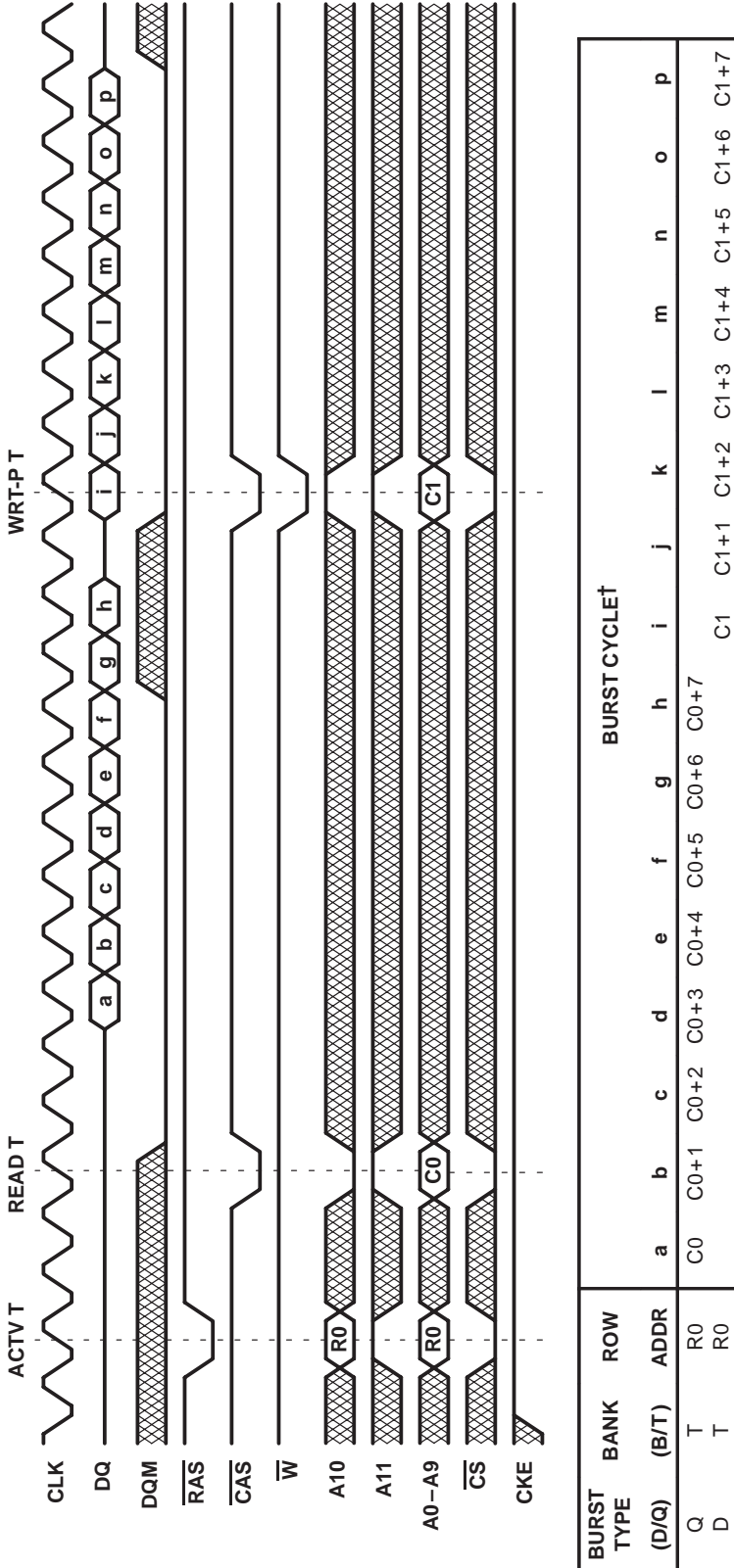

Figure 22. Write-Read Burst (CAS latency = 3, burst length = 2)

PARAMETER MEASUREMENT INFORMATION



† Column-address sequence depends on programmed burst type and starting column address C0 and C1 (see Table 6).
 NOTE A: This example illustrates minimum tRCD for the '626812-12 at 83 MHz.

Figure 23. Read-Write Burst With Automatic Deactivate (CAS latency = 3, burst length = 8)

PARAMETER MEASUREMENT INFORMATION

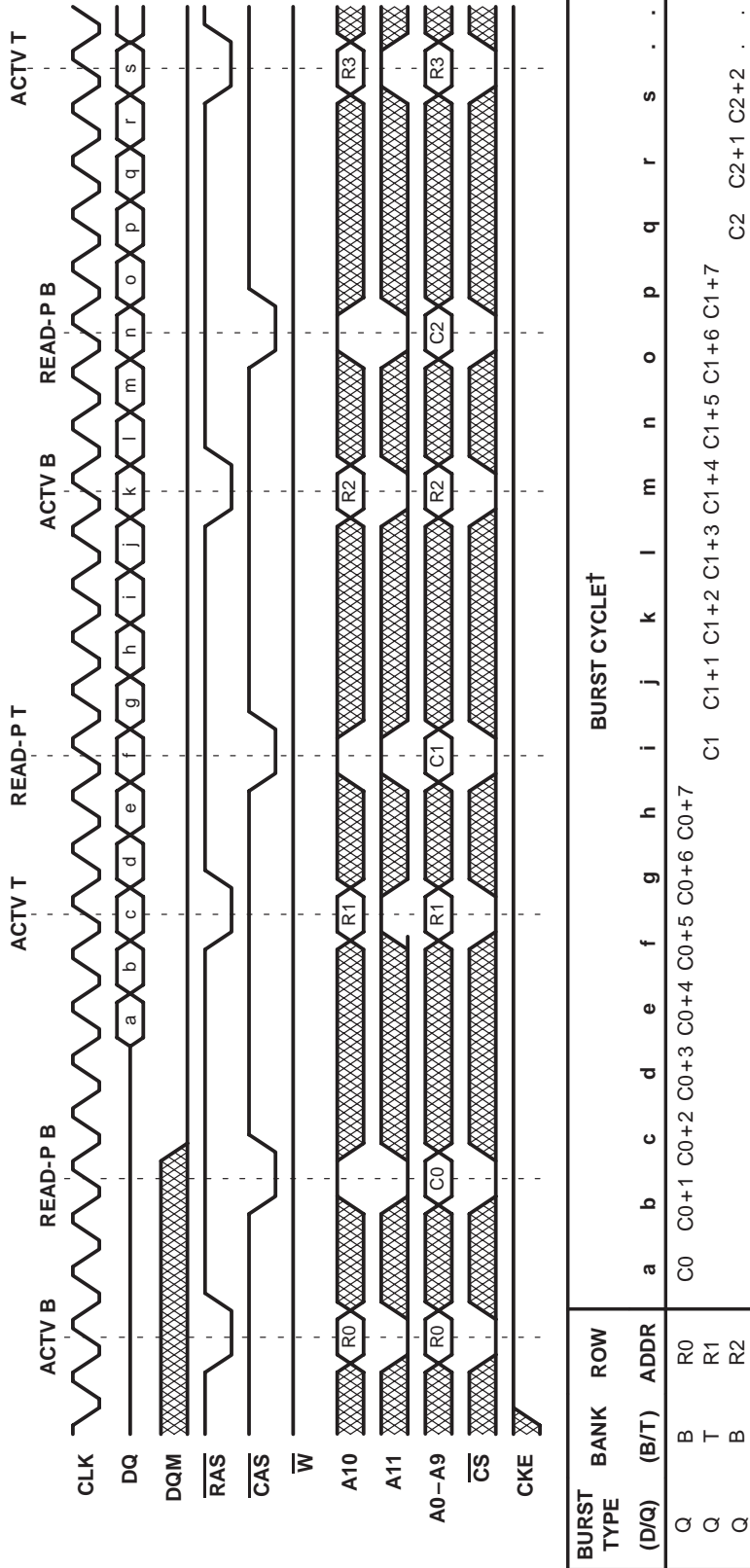

† Column-address sequence depends on programmed burst type and starting column address C0, C1, and C2 (see Table 6).
 NOTE A: This example illustrates minimum tRCD for the '626812-12 at 83 MHz.

Figure 24. Two-Bank Row-Interleaving Read Bursts With Automatic Deactivate (CAS latency = 3, burst length = 8)

PARAMETER MEASUREMENT INFORMATION

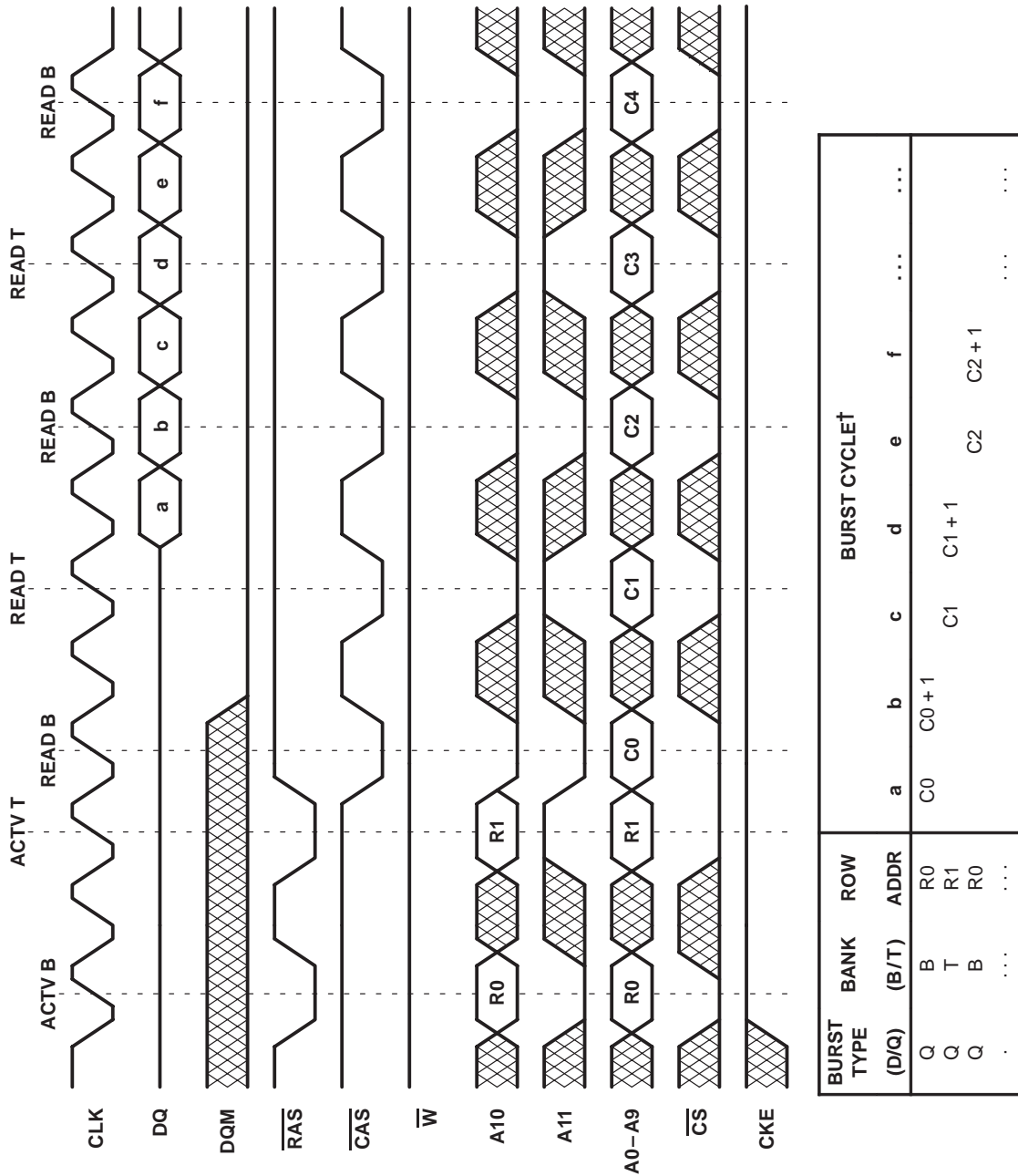

† Column-address sequence depends on programmed burst type and starting column addresses C0, C1 and C2 (see Table 4).

Figure 25. Two-Bank Column-Interleaving Read Bursts (CAS latency = 3, burst length = 2)

PARAMETER MEASUREMENT INFORMATION

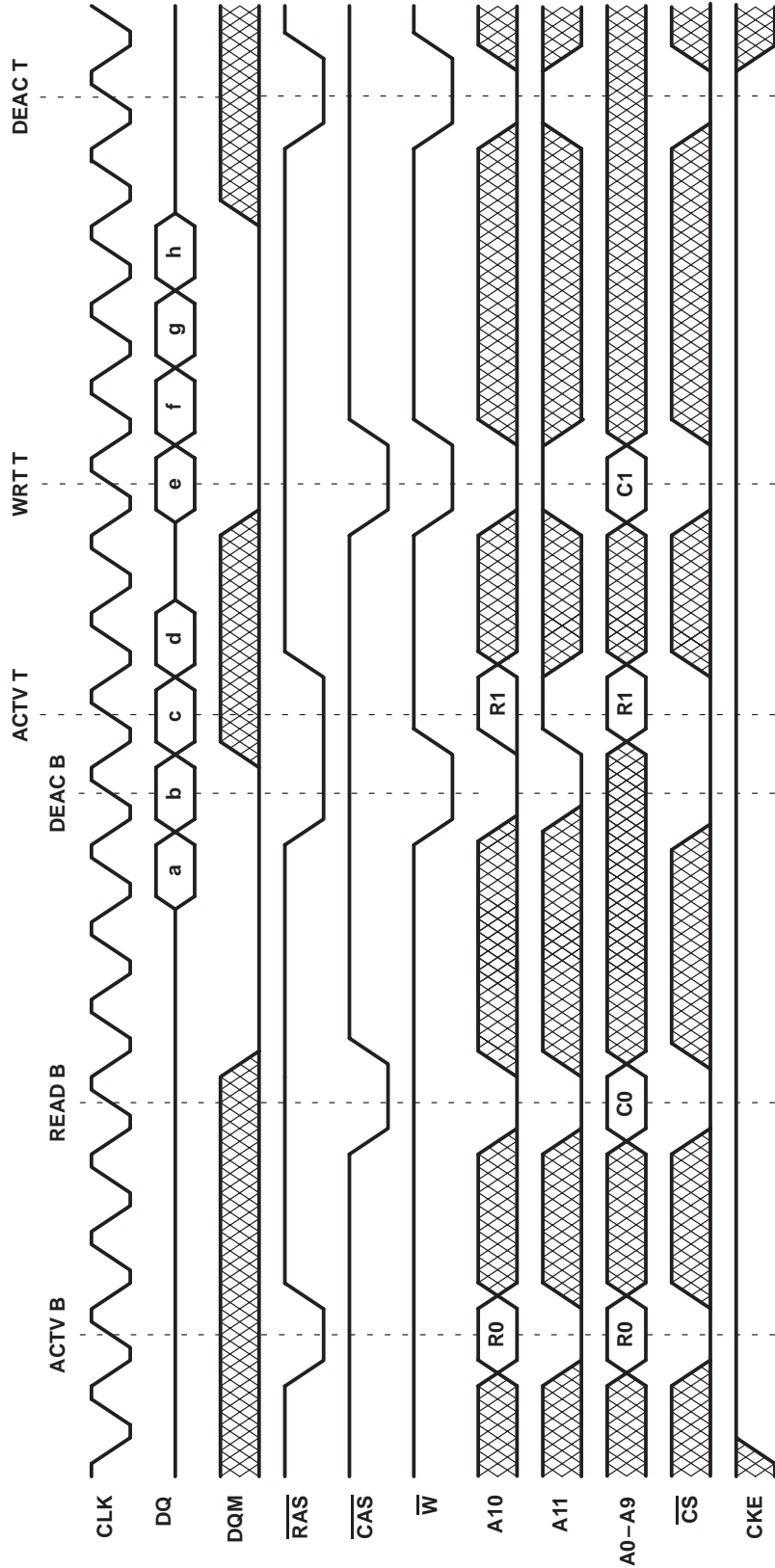

BURST TYPE	BANK	ROW	BURST CYCLE†							
(D/Q)	(B/T)	ADDR	a	b	c	d	e	f	g	h
Q	B	R0	C0	C0+1	C0+2	C0+3	C1	C1+1	C1+2	C1+3
D	T	R1								

† Column-address sequence depends on programmed burst type and starting column addresses C0 and C1. (see Table 5).
 NOTE A: This example illustrates a minimum t_{RCD} and t_{WR} for the '626812-12 at 83 MHz.

Figure 26. Read-Burst Bank B, Write-Burst Bank T (CAS latency = 3, burst length = 4)

PARAMETER MEASUREMENT INFORMATION

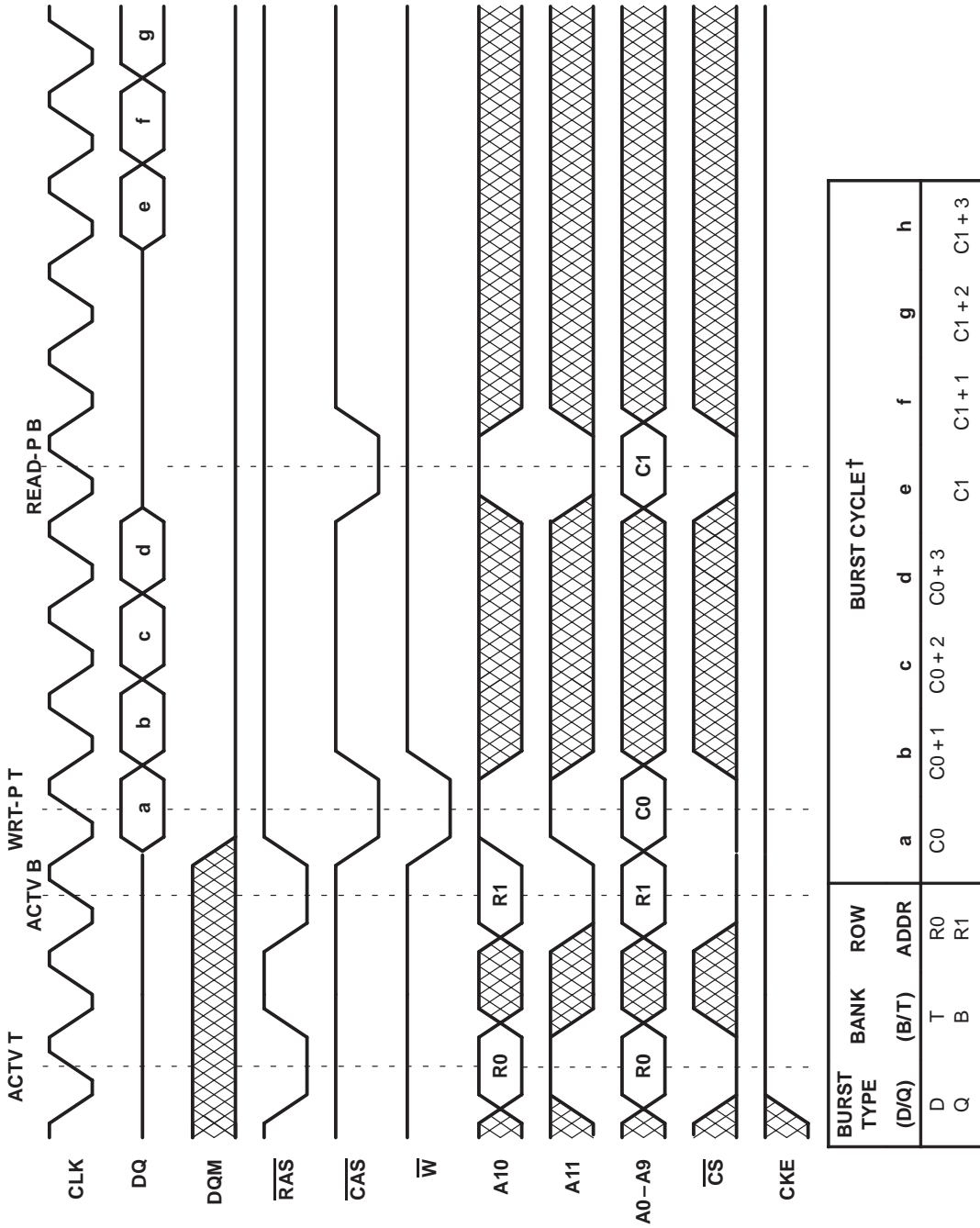

† Column-address sequence depends on programmed burst type and starting column address C0 and C1 (see Table 5).
 NOTE A: This example illustrates minimum nCWL for the '626812-12 at 83 MHz.

Figure 27. Write-Burst Bank T, Read-Burst Bank B With Automatic Deactivate (CAS latency = 3, burst length = 4)

PARAMETER MEASUREMENT INFORMATION

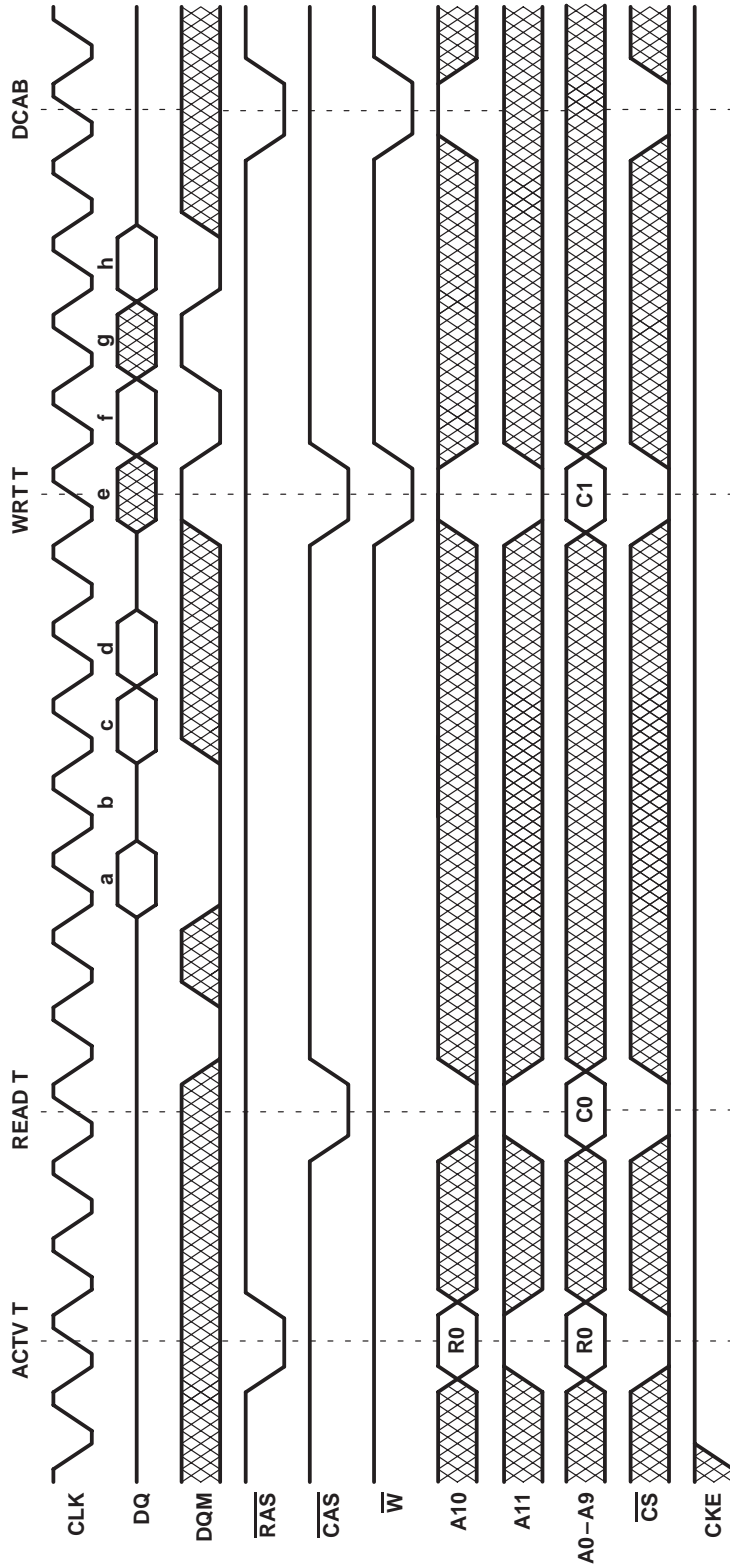

BURST TYPE (D/Q)	BANK (B/T)	ROW (R0, R1)	ADDR (C0, C1, C0+1, C0+2, C0+3)	a	b	c	d	e	f	g	h
Q	T	R0	C0	C0	C0+1	C0+2	C0+3	C1	C1+1	C1+2	C1+3
D	T	R1	C1	C1	C1+1	C1+2	C1+3	C1	C1+1	C1+2	C1+3

† Column-address sequence depends on programmed burst type and starting column address C0 and C1 (see Table 5).
 NOTE A: This example illustrates minimum tRCD for the '626812-12 at 83 MHz.

Figure 28. Data Mask (CAS latency = 3, burst length = 4)

PARAMETER MEASUREMENT INFORMATION

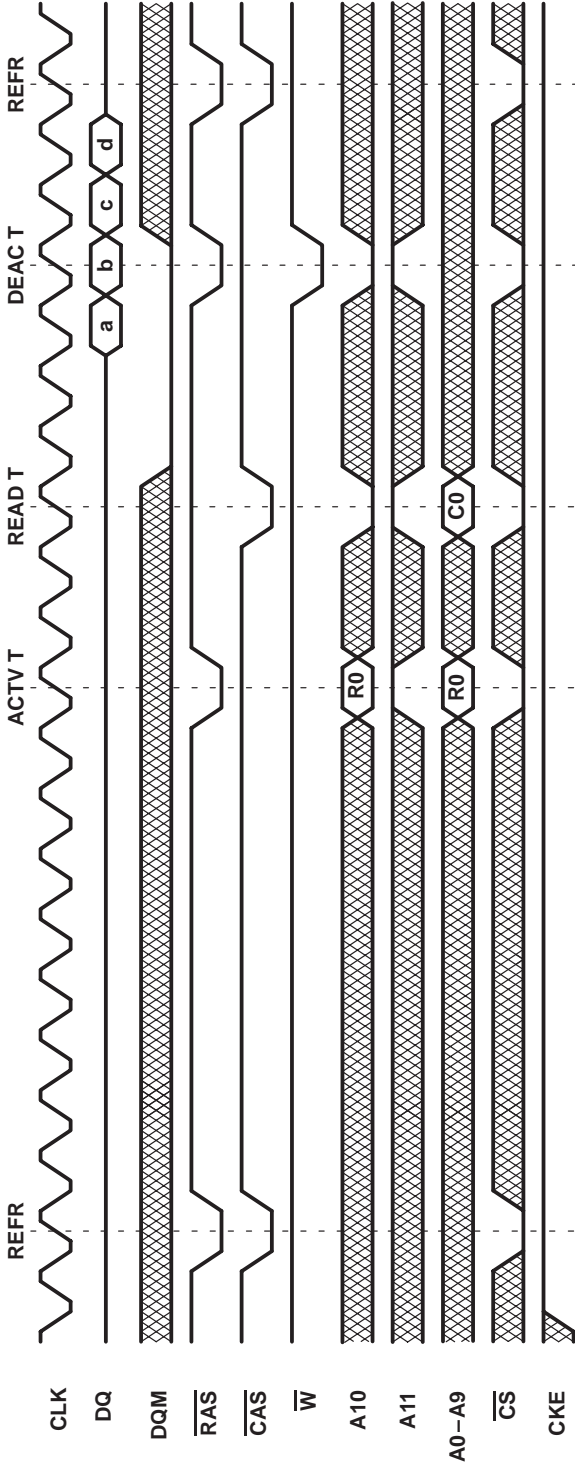

BURST TYPE	BANK (B/T)	ROW ADDR	BURST CYCLE†			
Q	T	R0	a	b	c	d
			C0	C0+1	C0+2	C0+3

† Column-address sequence depends on programmed burst type and starting column address C0 (see Table 5).
 NOTE A: This example illustrates minimum t_{PC} and t_{RCD} for the '626812-12 at 83 MHz.

Figure 29. Refresh Cycles (CAS latency = 3, burst length = 4)

PARAMETER MEASUREMENT INFORMATION

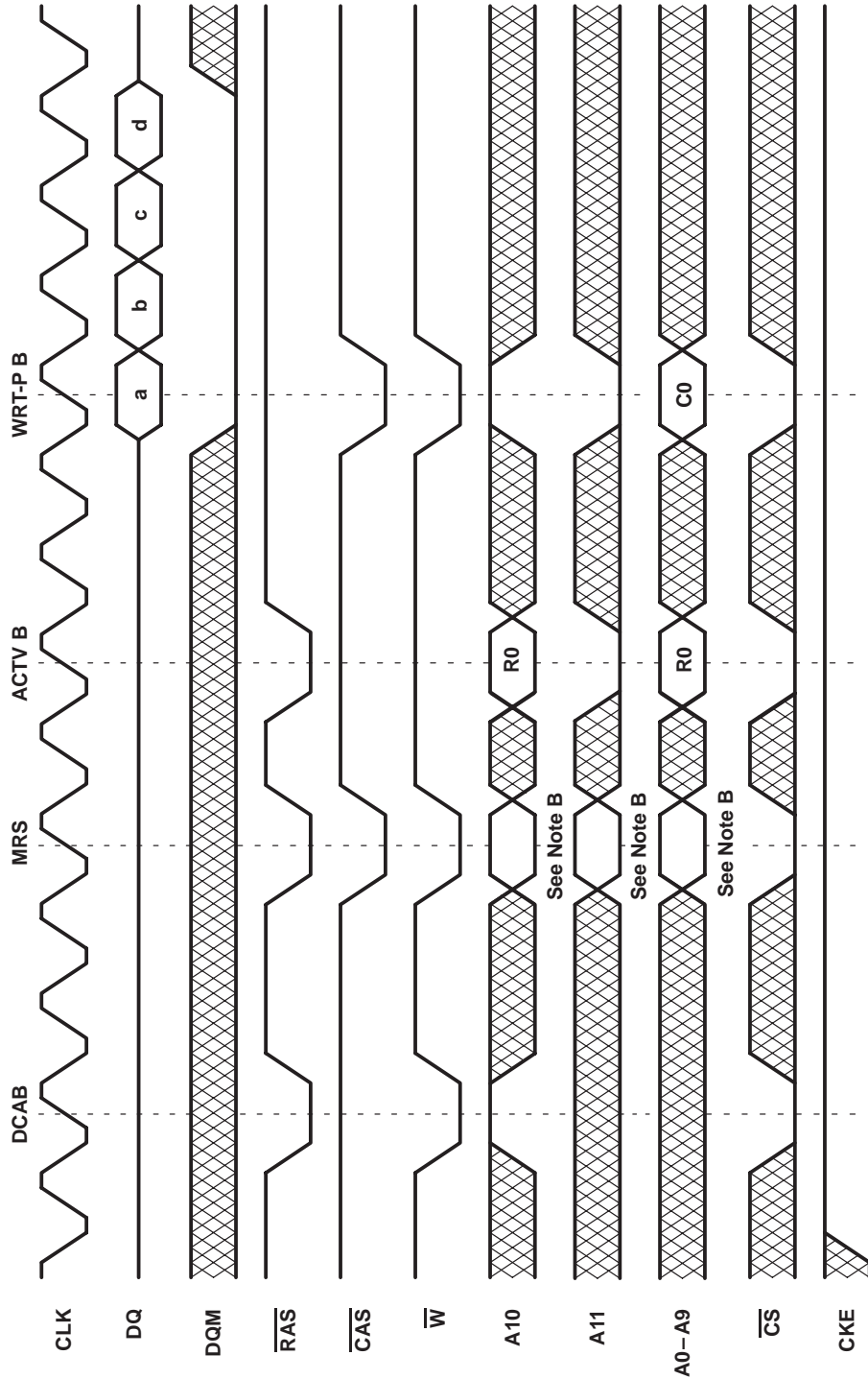

BURST TYPE	BANK	ROW	BURST CYCLE†			
(D/Q)	(B/T)	ADDR	a	b	c	d
D	B	R0	C0	C0+1	C0+2	C0+3

† Column-address sequence depends on programmed burst type and starting column address C0 (see Table 5).
 NOTES: A. This example illustrates minimum tRP, tRSA, and tRCD for the '626812-12 at 83 MHz.
 B. Refer to Figure 1

Figure 30. Set Mode Register (deactivate all, set mode register, write burst with automatic deactivate) (burst length = 4)

PARAMETER MEASUREMENT INFORMATION

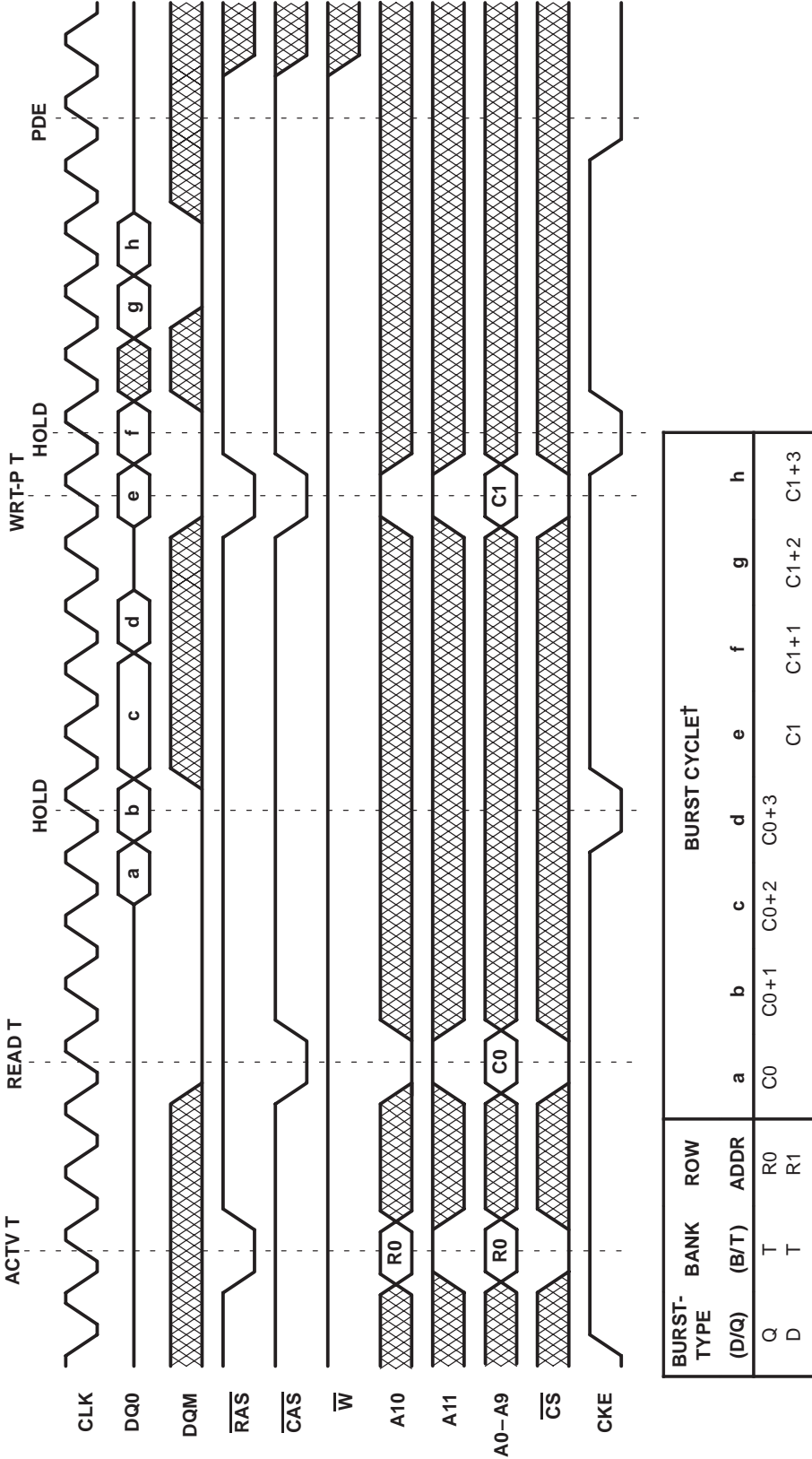

† Column-address sequence depends on programmed burst type and starting column address C0 and C1 (see Table 5).

Figure 31. CLK Suspend (HOLD) During Read Burst and Write Burst (CAS latency = 3, burst length = 4)

TMS626812
1048576 BY 8-BIT BY 2-BANK
SYNCHRONOUS DYNAMIC RANDOM-ACCESS MEMORY

SMOS687A - JULY 1996 - REVISED APRIL 1997

device symbolization

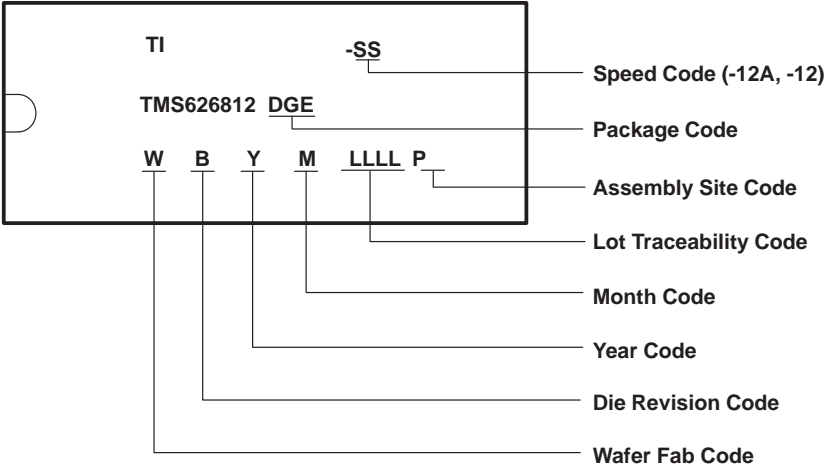

TMS626812
1048576-WORD BY 8-BIT BY 2-BANK
SYNCHRONOUS DYNAMIC RANDOM-ACCESS MEMORY
SMOS687A – JULY 1996 – REVISED MARCH 1997



IMPORTANT NOTICE

Texas Instruments and its subsidiaries (TI) reserve the right to make changes to their products or to discontinue any product or service without notice, and advise customers to obtain the latest version of relevant information to verify, before placing orders, that information being relied on is current and complete. All products are sold subject to the terms and conditions of sale supplied at the time of order acknowledgement, including those pertaining to warranty, patent infringement, and limitation of liability.

TI warrants performance of its semiconductor products to the specifications applicable at the time of sale in accordance with TI's standard warranty. Testing and other quality control techniques are utilized to the extent TI deems necessary to support this warranty. Specific testing of all parameters of each device is not necessarily performed, except those mandated by government requirements.

CERTAIN APPLICATIONS USING SEMICONDUCTOR PRODUCTS MAY INVOLVE POTENTIAL RISKS OF DEATH, PERSONAL INJURY, OR SEVERE PROPERTY OR ENVIRONMENTAL DAMAGE ("CRITICAL APPLICATIONS"). TI SEMICONDUCTOR PRODUCTS ARE NOT DESIGNED, AUTHORIZED, OR WARRANTED TO BE SUITABLE FOR USE IN LIFE-SUPPORT DEVICES OR SYSTEMS OR OTHER CRITICAL APPLICATIONS. INCLUSION OF TI PRODUCTS IN SUCH APPLICATIONS IS UNDERSTOOD TO BE FULLY AT THE CUSTOMER'S RISK.

In order to minimize risks associated with the customer's applications, adequate design and operating safeguards must be provided by the customer to minimize inherent or procedural hazards.

TI assumes no liability for applications assistance or customer product design. TI does not warrant or represent that any license, either express or implied, is granted under any patent right, copyright, mask work right, or other intellectual property right of TI covering or relating to any combination, machine, or process in which such semiconductor products or services might be or are used. TI's publication of information regarding any third party's products or services does not constitute TI's approval, warranty or endorsement thereof.

