



MLX90601 family

IR thermometer modules

Features and Benefits

- Remote temperature measurement
- Fully linearized signals
- Analog voltage output, digital PWM output and SPI interface
- Factory calibrated
- Rigid PCB with automotive protection circuitry, or flex circuit board.
- EEPROM ECC
- Open drain relay driver output

Applications

- Automotive climate control
- Toasters, microwave ovens and other applications that require temperature control
- Residential, commercial climate control and occupancy detection
- Industrial temperature transducer and monitoring applications

Ordering Information

| Part No | Ta | Suffix | Package | Type | Description | PCB |
|----------|----|--------|---------|------|---|-------|
| MLX90601 | E | | ZA | BAA | 8 bit Analog To -20C /120C, Ta 0C..50C | Rigid |
| MLX90601 | E | | ZA | DAA | PWM, To -20C /120C, Ta 0C..50C | Rigid |
| MLX90601 | E | | ZA | CAA | Digital SPI/PWM To -20C/120C, Ta 0C..50C, 5V supply | Rigid |
| MLX90601 | K | | ZA | BKA | 8 bit Analog To -20C /120C, Ta -20C..85C, 5V supply | Flex |
| MLX90601 | K | | ZA | CKA | Digital SPI/PWM To -20C/120C, Ta -20C..85C, 5V supply | Flex |

Notes: Ta ambient operating temperature range

MLX90601EZA-XXX: -40C / +85C

MLX90601KZA-XXX: -40C / +125C

1 Functional Diagrams

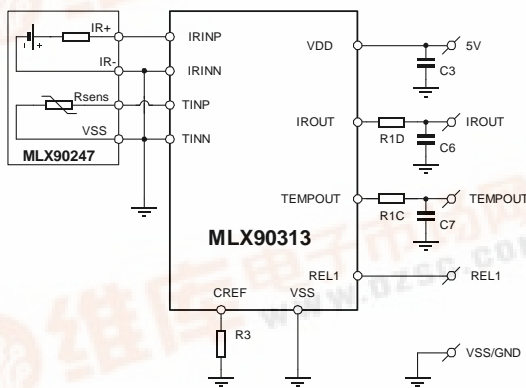

MLX90601 EZA-BAA
MLX90601 EZA-DAA

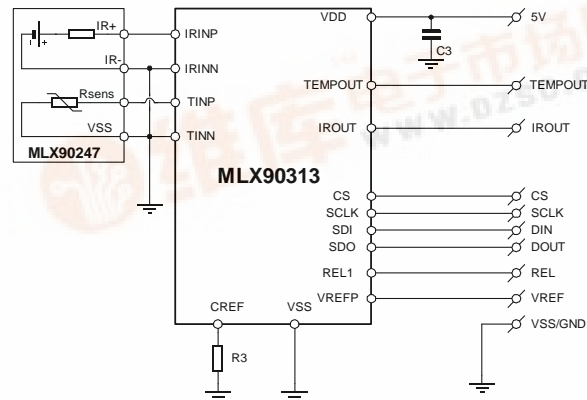

MLX90601 EZA-CAA
MLX90601 KZA-BKA
MLX90601 KZA-CKA



2 Description

The MLX90601 Family modules are versatile IR thermometer modules, which perform signal conditioning, linearisation and ambient temperature compensation. The modules are built around the MLX90313 IR sensor interface, which uses high performance chopper stabilized amplifiers, providing excellent noise performance. The sensing element is the MLX90247 discrete IR thermopile sensor. The modules are delivered factory calibrated. The output signals can be analog voltage outputs; PWM coded digital outputs, or a bi-directional SPI compatible serial interface. All output signals are linear with the applied temperature.

All modules feature the open drain relay driver output available in MLX90313.

Several types of modules are available. First types are the modules for automotive applications, which have additional ESD protection circuitry on board. These modules can

have an analog voltage output (MLX90601EZA-BAA), or a digital PWM coded output (MLX90601EZA-DAA). The substrate is in this case a FR4 PCB with a 5 pin through-hole connector.

Alternatively there are some modules targeted for industrial or consumer applications. These modules can have also analog outputs (MLX90601KZA-BKA) or PWM outputs (MLX90601KZA-CKA and MLX90601EZA-CAA). All three modules have a SPI interface available for full programmability.

The MLX90601KZA-BKA and MLX90601KZA-CKA are built on a flexible polyamide substrate, making building in the sensor very easy.

The user can choose now the most suited module depending on electrical and mechanical needs.

CONTENTS

| | | |
|-----------|--|-----------|
| 1 | FUNCTIONAL DIAGRAMS | 1 |
| 2 | DESCRIPTION | 2 |
| 3 | GLOSSARY OF TERMS | 5 |
| 4 | ABSOLUTE MAXIMUM RATINGS | 6 |
| 5 | MLX90601 ELECTRICAL SPECIFICATIONS..... | 6 |
| 6 | GENERAL DESCRIPTION | 8 |
| 6.1 | THEORY OF OPERATION | 8 |
| 6.2 | SENSOR CHARACTERISTICS | 8 |
| 6.3 | ACCURACY..... | 8 |
| 7 | MLX90601EZA-BAA | 10 |
| 7.1 | KEY PROPERTIES | 10 |
| 7.2 | GENERAL DESCRIPTION | 10 |
| 7.3 | PHYSICAL OUTLINE | 12 |
| 7.4 | PIN-OUT AND PIN DESCRIPTIONS | 12 |
| 7.5 | ELECTRICAL SPECIFICATIONS | 13 |
| 7.6 | CALIBRATION DETAILS..... | 13 |
| 7.7 | APPLICATIONS INFORMATION | 14 |
| 8 | MLX90601EZA-DAA | 15 |
| 8.1 | KEY PROPERTIES | 15 |
| 8.2 | GENERAL DESCRIPTION | 15 |
| 8.3 | PHYSICAL OUTLINE | 17 |
| 8.4 | PIN-OUT AND PIN DESCRIPTIONS | 18 |
| 8.5 | ELECTRICAL SPECIFICATIONS | 18 |
| 8.6 | CALIBRATION DETAILS..... | 19 |
| 8.7 | APPLICATIONS INFORMATION | 20 |
| 9 | MLX90601EZA-CAA | 21 |
| 9.1 | KEY PROPERTIES | 21 |
| 9.2 | GENERAL DESCRIPTION | 21 |
| 9.3 | SERIAL PERIPHERAL INTERFACE (SPI) | 23 |
| 9.4 | PHYSICAL OUTLINE | 26 |
| 9.5 | PIN-OUT AND PIN DESCRIPTIONS | 26 |
| 9.6 | ELECTRICAL SPECIFICATIONS | 27 |
| 9.7 | CALIBRATION DETAILS..... | 28 |
| 9.8 | APPLICATIONS INFORMATION | 29 |
| 10 | MLX90601KZA-BKA | 30 |
| 10.1 | KEY PROPERTIES | 30 |
| 10.2 | GENERAL DESCRIPTION | 30 |
| 10.3 | SERIAL PERIPHERAL INTERFACE (SPI) | 32 |
| 10.4 | PHYSICAL OUTLINE | 35 |
| 10.5 | PIN-OUT AND PIN DESCRIPTIONS | 35 |
| 10.6 | ELECTRICAL SPECIFICATIONS | 36 |
| 10.7 | CALIBRATION DETAILS..... | 36 |



| | | |
|-----------|---|-----------|
| 10.8 | APPLICATIONS INFORMATION | 37 |
| 11 | MLX90601KZA-CKA | 38 |
| 11.1 | KEY PROPERTIES | 38 |
| 11.2 | GENERAL DESCRIPTION | 38 |
| 11.3 | SERIAL PERIPHERAL INTERFACE (SPI) | 40 |
| 11.4 | PHYSICAL OUTLINE | 43 |
| 11.5 | PIN-OUT AND PIN DESCRIPTIONS | 43 |
| 11.6 | ELECTRICAL SPECIFICATIONS | 44 |
| 11.7 | CALIBRATION DETAILS..... | 45 |
| 11.8 | APPLICATIONS INFORMATION | 45 |
| 12 | ESD PRECAUTIONS..... | 46 |
| 13 | RELIABILITY INFORMATION | 46 |
| 14 | FAQ..... | 46 |
| 15 | APPENDIX A: SPI INTERFACING TO AUTOMOTIVE MODULES..... | 48 |
| 15.1 | COMPONENT REFERENCES..... | 48 |
| 15.2 | SPI COMMUNICATION CABLE PIN-OUT..... | 48 |

3 Glossary of Terms

ADC: Analog to Digital Converter

Ambient Compensation: The IR signal captured by a thermopile sensor is not only dependent on the temperature of the object (T_{object}) but also on the temperature of the sensor itself. Therefore the IR signal is compensated for this effect by means of the measured sensor temperature (T_{ambient}). This rather complex calculation is performed in the linearisation unit of MLX90313.

Chopper Amplifier: Special amplifier configuration aimed at ultra low offset.

DAC: Digital to Analog Converter.

EEPROM: Non-volatile memory that can be electrically erased and rewritten. This type of memory is used to store configuration and calibration data for the module.

ECC: Error Checking and Correction. The EEPROM on board of MLX90313 is equipped with a checking and correction feature based on the Hamming Code method.

IR: Infrared. Every object emits infrared radiation in relation to its temperature. This effect can be used to measure this temperature without the need for physical contact.

Linearisation: The signal from a thermopile is not linear with the object temperature. MLX90313 is therefore equipped with a digital calculation unit that produces an output that is linear with the object temperature.

POR: Power-on reset: Reset circuit that starts the digital system in a known state whenever the supply voltage is cycled

PSSR: Power Supply Rejection Ratio: Measure for an amplifier's immunity to disturbances on the supply connections.

PTC: See Thermistor

T_a, T_{ambient}: The temperature of the IR sensor.

Target: or Object: The object the IR module is aimed at.

Thermistor: Temperature dependant resistor. Basically there are 2 types. The types that increase their resistance with rising temperature are PTC (positive thermal coefficient) type. The ones that decrease their resistance with rising temperature we call NTC (negative thermal coefficient) type. The MLX90313 can work with both types. The MLX90601 modules are equipped with sensors that use PTCs.

To, T_{object}: The temperature of the object one wishes to measure with the module

4 Absolute Maximum Ratings

Automotive Grade modules

MLX90601EZA-BAA – MLX90601EZA-DAA

| | |
|--------------------------------------|---------------|
| Voltage, V_{DD} (over-voltage) | 80V |
| Supply Voltage, V_{DD} (operating) | 5.5V |
| Supply Current, I_{DD} | 6mA |
| Operating Temperature Range, T_A | -40°C / 105°C |
| ESD Sensitivity (AEC Q100 002) | 4kV |

Flexible modules

MLX90601KZA-CKA – MLX90601KZA-BKA

| | |
|--------------------------------------|---------------|
| Voltage, V_{DD} (over-voltage) | 7V |
| Supply Voltage, V_{DD} (operating) | 5.5V |
| Supply Current, I_{DD} | 6mA |
| Operating Temperature Range, T_A | -40°C / 125°C |
| ESD Sensitivity (AEC Q100 002) | 1kV |

PCB SPI module

MLX90601EZA-CAA

| | |
|--------------------------------------|---------------|
| Voltage, V_{DD} (over-voltage) | 7V |
| Supply Voltage, V_{DD} (operating) | 5.5V |
| Supply Current, I_{DD} | 6mA |
| Operating Temperature Range, T_A | -40°C / 105°C |
| ESD Sensitivity (AEC Q100 002) | 1kV |

Exceeding the absolute maximum ratings may cause permanent damage. Exposure to absolute-maximum rated conditions for extended periods may affect device reliability.

5 MLX90601 Electrical Specifications

DC Operating Parameters $T_A = -40^{\circ}\text{C}$ to 125°C , $V_{DD} = 4.75\text{V}$ to 5.25V (unless otherwise specified)

| Parameter | Symbol | Test Condition | Min | Typ | Max | Unit |
|---|--------|------------------------|-----|-----|---------|------------------------|
| Regulator and consumption | | | | | | |
| POR threshold voltage | Vpor | | 1.1 | 1.3 | 1.5 | V |
| IR-chain amplifier and output driver | | | | | | |
| Power supply rejection ratio | PSSR | $f \leq 100\text{kHz}$ | 75 | | | dB |
| Input referred white noise | Vnir | rms-value | | | 25 | nV/ $\sqrt{\text{Hz}}$ |
| Chopper frequency | fc | | | 8 | | kHz |
| Output voltage range | | IROUT | 0 | | Vdd-0.2 | V |
| Output source current | Iod | IROUT | 1 | | | mA |
| Output sink current | Ios | IROUT | 20 | | | μA |
| DC Output impedance, drive | rod | IROUT | | | 10 | Ω |
| DC Output impedance, sink | ros | IROUT | | | 100 | Ω |
| Amplifier bandwidth | BW | | | 500 | | Hz |
| Temp-chain amplifier and output driver | | | | | | |
| Power supply rejection ratio | PSSR | $f \leq 100\text{kHz}$ | 75 | | | dB |
| Input referred white noise | Vntemp | rms-value | | | 400 | nV/ $\sqrt{\text{Hz}}$ |
| Chopper frequency | fc | | | 15 | | kHz |
| Output voltage range | ORtemp | TEMPOUT | 0 | | Vdd-0.2 | V |
| Output source current | Iod | TEMPOUT | 1 | | | mA |
| Output sink current | Ios | TEMPOUT | 20 | | | μA |

5 MLX90601 Electrical Specifications

DC Operating Parameters $T_A = -40^{\circ}\text{C}$ to 125°C , $V_{DD} = 4.75\text{V}$ to 5.25V (unless otherwise specified)

| Parameter | Symbol | Test Condition | Min | Typ | Max | Unit |
|-------------------------------------|--------|------------------|----------------------|-------|---------------|---------------|
| AC Output impedance | ro | TEMPOUT | | | 100 | Ω |
| Amplifier bandwidth | BW | | | 500 | | Hz |
| Rel1 open drain relay driver | | | | | | |
| High voltage protections | | | 32 | | | V |
| output impedance | Ro | | | 10 | | Ω |
| ADC | | | | | | |
| Monotonic | | | guaranteed by design | | | |
| Differential non-linearity | DNL | | | | 0.4 | LSB |
| Integral non-linearity | INL | | | | $\frac{1}{2}$ | LSB |
| Gain error | | full scale | | | 1 | LSB |
| Total input-referred noise | | Vref=3V | | | 0.2 | LSB |
| DAC | | | | | | |
| Resolution | | | | 8 | | bit |
| Monotonic | | | guaranteed by design | | | |
| Differential non-linearity | DNL | | | | $\frac{1}{2}$ | LSB |
| Integral non-linearity | INL | | | | $\frac{1}{2}$ | LSB |
| PWM | | | | | | |
| PWM Clock period | Tclk | | 45 | 50 | 55 | μs |
| PWM Total period | T | | 92.16 | 102.4 | 112.64 | ms |
| Leading buffer time | t1 | % of T | | 12.5 | | % |
| Trailing buffer time | t5 | % of T | | 12.5 | | % |
| Duty cycle high | t2 | % of T | 0 | | 50 | % |
| Duty cycle low | t3 | % of T | 0 | | 50 | % |
| Error signal | t4 | % of T | | 25 | | % |
| Rise time* | | 10% to 90% of Vh | 13.3 | | 100 | μs |
| Fall time* | | 90% to 10% of Vh | 13.3 | | 100 | μs |
| Output voltage high | Vh | Ihigh=2mA | 4 | | | V |
| Output voltage low | VI | Ilow=2mA | | | 1 | V |

*Without external loading

6 General Description

6.1 Theory of operation

The MLX90601 modules are developed especially to make IR temperature sensing easy. All modules have a linearised output signal. Also they are factory calibrated, so making all modules interchangeable. Also this relieves customers from complex calibration procedures.

All modules have a MLX90247 thermopile sensor as IR sensing element. The output of this sensor is a function of both Object (IR) and ambient temperature. Ideally the output voltage of the thermopile sensor is:

$$V_{ir} = \alpha(T_o^4 - T_a^4)$$

Where T_o is Object temperature in Kelvin, and T_a is the ambient temperature in Kelvin. Alpha is a device constant. It is clear from above equation that the ambient temperature must be known before the object temperature can be calculated. Therefore the MLX90247 thermopile sensor has a thermistor built-in. Melexis has designed a powerful ASIC to perform the signal processing of the thermopile output voltage. MLX90313 amplifies the signals coming from MLX90247 and converts them to digital by means of two high performance, low noise, chopper stabilized amplifiers and the 12-bit analog to digital converter. The digital unit on the interface then performs the ambient compensation of the IR signal. This results in two temperature signals, one representing the temperature of the object the IR sensor is pointed at (T_{object}) and one representing the temperature of the sensor ($T_{ambient}$). Both signals are then linearised and presented at the outputs in analog of PWM coded form. When using modules that have also SPI, the temperature registers can be read directly through the serial interface.

The linearisation unit can only operate when both T_a (ambient temperature) and T_o (object temperature) are both in a distinct calibrated range. This has an important implication for the ambient temperature. When the modules are used outside the calibrated ambient temperature, the object temperature is calculated using a false ambient temperature, resulting in an erroneous output signal. If the ambient temperature is below the ambient calibration range, the OVL flag in the SPI register is set and the temperature data bits are all zero. For analog output modules, the output will be zero volts. Alternatively, if the ambient temperature is above the ambient calibration range, the OVH flag in the SPI register is set and the temperature data bits are all one. For analog output modules, the output will be 4.5 volts. When returning into calibrated ambient temperature range, the module will resume normal operation.

Our standard products have such ranges that they can suit a maximum number of applications. Currently there are four different versions of modules offered.

6.2 Sensor characteristics

All modules have the same thermopile sensor. For detailed specification we refer to the datasheet on MLX90247, available from the Melexis web site. In a calibrated module the linearisation unit of MLX90313 takes all characteristics of the sensor into account, including all process variations they are subject to.

The TO-39 sensor housing of the thermopile has a 2.5mm diameter aperture, resulting in a 70° full angle field of view, for 90% of the IR energy. The silicon filter used as IR-window is treated with an antireflective coating that will pass minimum 75% of IR radiation in the wave length band from 7.5µm to 13.5µm. Below 5µm, 99.5% of incoming radiation is reflected by the filter. This makes the sensor insensitive to visible light.

6.3 Accuracy

Accuracy of the module depends mainly on calibration precision. For absolute accuracy please refer to calibration details for the appropriate module. The error of the output depends on both object and ambient temperature. Repeatability and stability are very good, the error is < 0.4C, but both ambient and object

temperature must be kept stable. For making relative measurements care must be observed. The MLX90313 uses a piecewise modified quadratic approximation method, and on the reference points, the output can change with several tenths of degrees. Of course, the absolute accuracy will always be within specification.

7 MLX90601EZA-BAA

7.1 Key properties

- Automotive use
- analog output signals with 8 bit resolution
- relay comparator
- only 5 connections

7.2 General description

The MLX90601EZA-BAA is a module that is targeted for automotive use. In addition to the small amount of components like the sensor, ASIC etc there are also 2 RC protection circuits on the IROUT and TEMPOUT pins. This allows the module to be used in automotive environments.

The Object temperature information is available at the IROUT pin. The ambient temperature information is available on the TEMPOUT pin. The resolution of the output D/A converter is 8bit. The output drivers have a maximum output voltage of 4.5V when the maximum calibrated temperature is reached.

If the ambient temperature is out of the calibrated temperature range, the correct object temperature cannot be calculated. For applications where the ambient temperature can rise above the maximum calibrated temperature, the ambient temperature output must be monitored to make sure the object temperature is valid.

Next to the temperature outputs there is also a relay driver output. The relay driver has a threshold that is pre-set to 50 °C, with a hysteresis of 5 °C. Note that this module has no SPI interface connector available. If the user wants to reconfigure this type of module, this can be done with the EVB board and a special test clip. Refer to appendix A for details.

The relation of the output voltage to the temperature is defined as follows:

$$T = \frac{V_{out}}{4.5} * (T_{max} - T_{min}) + T_{min}$$

where:

- T measured temperature
- V_{out} analog output voltage on IROUT or TEMPOUT pins.
- T_{min} minimal calibrated temperature
- T_{max} maximum calibrated temperature

Refer to calibration details for calibrated ranges info

A graphical representation is depicted below.

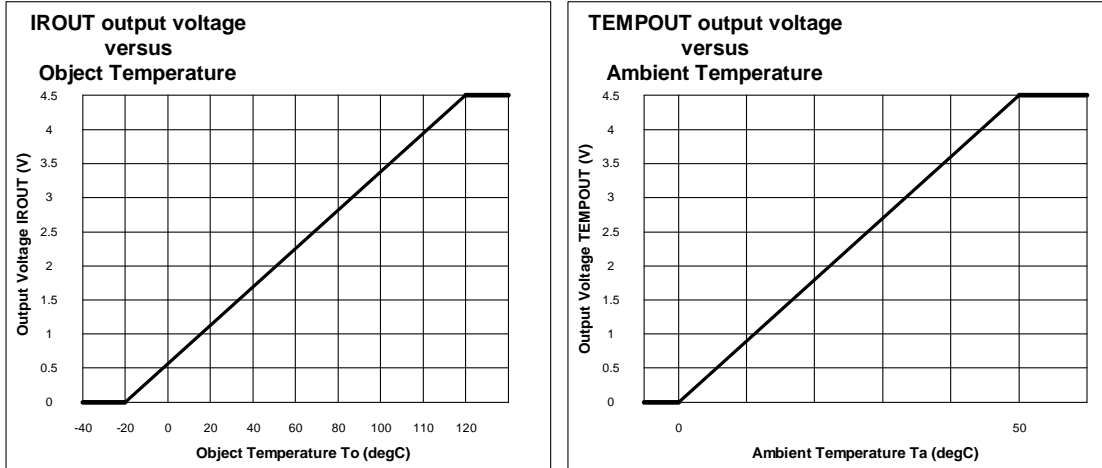

The behavior of the module outside the calibrated ranges is shown below:

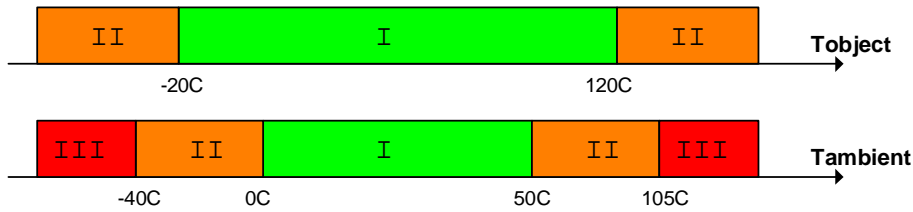

Module operating conditions

| T object in range | T ambient in range | Effect on outputs |
|-------------------|--------------------|---|
| I | I | Object temperature output is working normal Ambient temperature output is working normal |
| II | I | Object temperature output will be clamped 0V ($T_o < -20C$) or clamped at 4.5V ($T_o > 120C$). Ambient temperature output is working normal |
| I or II | II | BOTH temperature outputs will be clamped 0V ($T_a < 0C$) or clamped at 4.5V ($T_a > 50C$). |
| I or II | III | The module may be damaged if operated outside the ambient temperature range. BOTH temperature outputs will be clamped 0V ($T_a < 0C$) or clamped at 4.5V ($T_a > 50C$). |

7.3 Physical outline

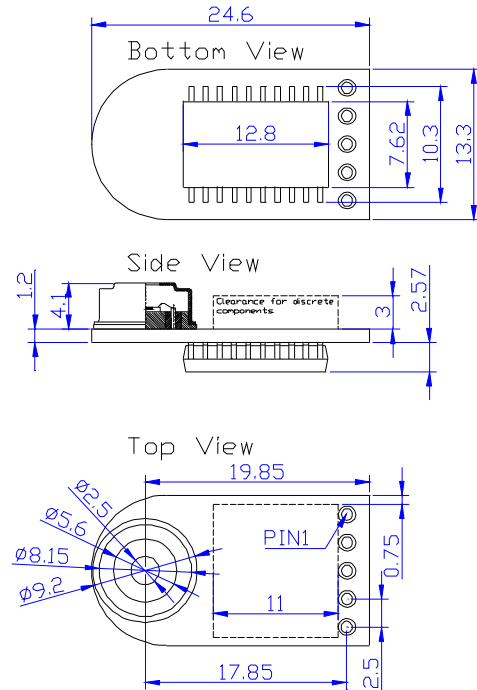

7.4 Pin-out and pin descriptions

| pin | name | pin-out information | function |
|-----|---------|------------------------------------|----------|
| 1 | IROUT | analog output infrared temperature | |
| 2 | TEMPOUT | analog output ambient temperature | |
| 3 | VDD | Supply voltage | |
| 4 | REL1 | Relay output | |
| 5 | VSS | Ground connection | |

IROUT IROUT analog voltage output pin. The voltage at this pin is a linear representation of Tobject, the temperature of the object the IR sensor is pointed at.

TEMPOUT Ambient temperature analog voltage output pin. The voltage at this pin is a linear representation of Tambient, the temperature of the IR sensor, as measured by the PTC inside MLX90247.

VDD Supply pin

REL1 Open drain relay driver output. The typical on-resistance of this driver is <10 Ohms.

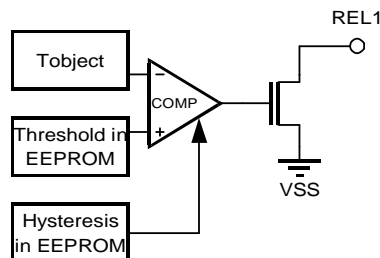

The comparator is a digital comparator, with a resolution of 12 bits. By default the input polarity is inverting. Threshold and hysteresis values are version dependent. These settings can be changed by factory programming on request. Refer to calibration settings for factory preset values.

VSS Supply pin (0V)

7.5 Electrical specifications

| Parameter | symbol | condition | min | typ | max | unit |
|-------------------------------------|--------|-----------|------|-----|-----|------|
| Supply Voltage | | | | | | |
| Supply voltage range | VDD | | 4.75 | 5 | 6 | V |
| Power consumption | IDD | Ta=25C | | 5 | 5.6 | mA |
| analog outputs IROUT/TEMPOUT | | | | | | |
| D/A converter resolution | | | | 8 | | Bits |
| Output source current | Iod | | 1 | | | mA |
| Output sink current | Ios | | 20 | | | uA |
| AC Output impedance | ro | | | | 100 | Ω |
| Capacitive load | Cmax | | | | 100 | nF |
| Rel1 open drain relay driver | | | | | | |
| output impedance | Ro | | | 10 | | Ohms |
| High voltage protections | | | 32 | | | V |

7.6 Calibration details

| | |
|--|-----------|
| Maximum calibrated object temperature | 120°C |
| Minimum calibrated object temperature | -20°C |
| Object temperature Accuracy | ±2°C |
| Maximum calibrated ambient temperature | 50°C |
| Minimum calibrated ambient temperature | 0°C |
| Ambient temperature Accuracy | ±1°C |
| Response time | 500ms |
| REL1 source | Tobject |
| REL1 polarity (*) | Inverting |
| REL1 threshold | 50°C |
| REL1 hysteresis | 5°C |
| Emissivity | 0.99 |

Note: Comparator polarity:

Inverting: relay switches OFF if temperature is above the threshold.

Non-inverting: relay switches ON if temperature is above the threshold.

7.7 Applications information

Connection of the MLX90601 module into an application is straightforward. The 5V regulated supply should be connected between pin 3 (VDD) and pin 5 (VSS).

The outputs can be measured relative to VSS at pin 1 (IROUT) for T_{object} and pin 2 (TEMPOUT) for $T_{ambient}$, e.g. by means of a voltmeter. In an actual application the module outputs can be directly connected to the A/D inputs of a microcontroller, e.g. as a replacement for a conventional temperature sensor.

In many applications, the ambient temperature of the sensor is not needed. In this case, pin 2 can simply be left open.

The REL1 signal at pin 4 can be used as input for a digital I/O or to drive a relay (not shown). In case of a digital input the microcontroller must have internal pull-up resistors or an external pull-up resistor must be added.

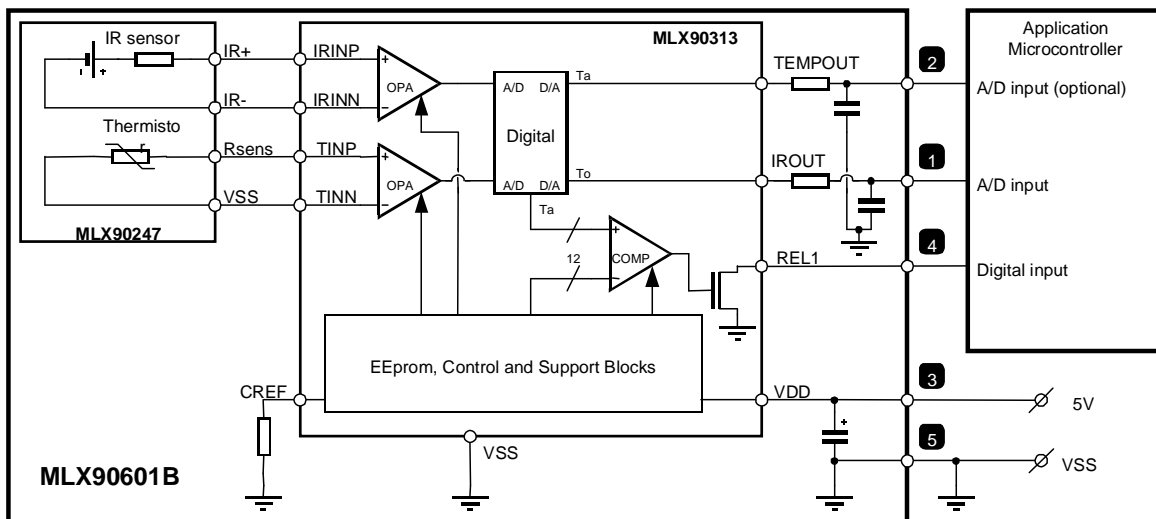

8 MLX90601EZA-DAA

8.1 Key properties

- Automotive use
- PWM coded output signals with 10 bit resolution
- ambient temperature underflow and overflow flagging
- relay comparator
- only 5 connections

8.2 General description

The MLX90601EZA-DAA is a module that is targeted for automotive use. In addition to the small amount of components like the sensor, ASIC etc there are also 2 RC protection circuits on the IROUT and TEMPOUT pins. This allows the module to be used in automotive environments.

The Object temperature information is available at the IROUT pin. The ambient temperature information is available on the TEMPOUT pin. The resolution of the Pulse Width Modulated output is 10 bits. Next to the temperature information, these outputs can also flag ambient temperature underflow and overflow. The module has an on-board ECC (EEPROM consistency check), that checks the stored calibration constants and settings. In case of failure, the output fill flag this condition.

If the ambient temperature is out of the calibrated temperature range, both PWM signals will flag this condition, and the object and ambient temperatures will not be available until the ambient temperature is back in the calibrated temperature range.

Next to the temperature outputs there is also a relay driver output. The relay driver has a threshold that is pre-set to 50 °C, with a hysteresis of 5 °C. Note that this module has no SPI interface connector available. If the user wants to reconfigure this type of module, this can be done with the EVB board and a special test clip. Refer to appendix A for details.

The PWM coding format is depicted below

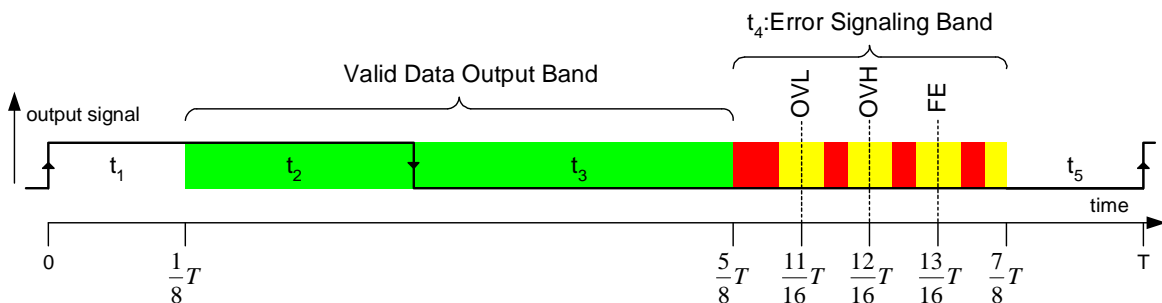

The PWM signal has a period of 102.4ms typical consisting of 2048 clock cycles of 50µs. Every frame starts with a leading buffer time, t₁, during which the signal is always high, as shown in the figure. The leading buffer time is followed by a slot for the useful data signal starting at 1/8T ending at 5/8T, where the ratio t₂/(t₂+t₃) is the representation of the output value. t₄ is a slot for signaling of special conditions, such as out of range measurement of the sensor temperature, T_{ambient} and the occurrence of a fatal EEPROM error, i.e. an error that can no longer be corrected automatically by the ECC circuitry of MLX90313.

PWM duty cycle overview

| Condition | Duty cycle | nominal timing |
|-------------------------|---------------|-----------------|
| Normal operation | 12.5% - 62.5% | 12.8 ms - 64 ms |
| OVL: Tambient underflow | 68.75 % | 70.4 ms |
| OVH: Tambient overflow | 75 % | 76.8 ms |
| FE: Fatal Error EEPROM | 81.25% | 83.2 ms |

The relation of the output voltage to the temperature is defined as follows:

$$T = \frac{DutyCycle - 12.5\%}{50\%} * (T_{max} - T_{min}) + T_{min}$$

where:

- T measured temperature
 - $DutyCycle$ Duty Cycle of the IROUT or TEMPOUT PWM signals.
 - T_{min} minimal calibrated temperature
 - T_{max} maximum calibrated temperature
- Refer to calibration details for calibrated ranges info

A graphical representation is depicted below.

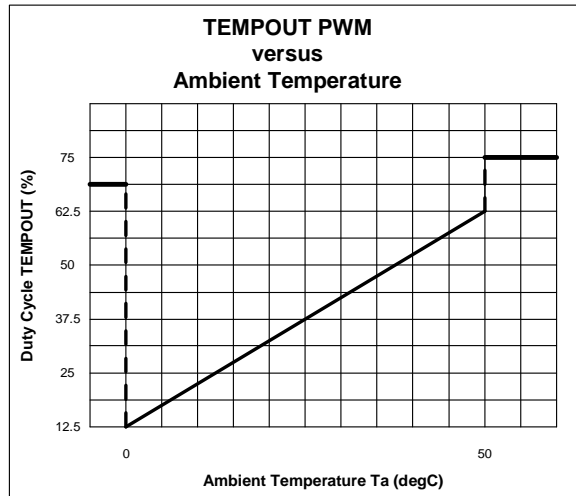
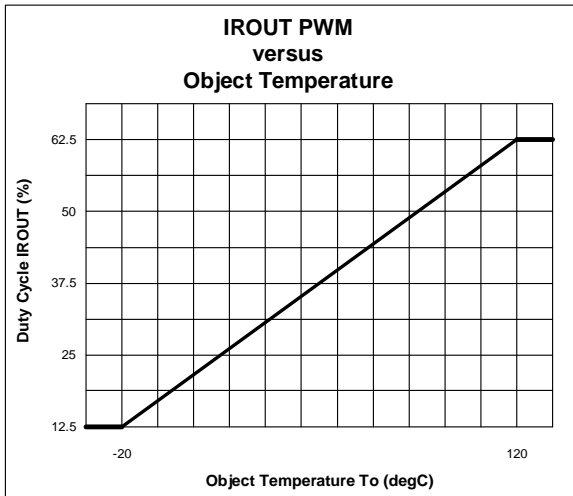

The behavior of the module outside the calibrated ranges is shown below:

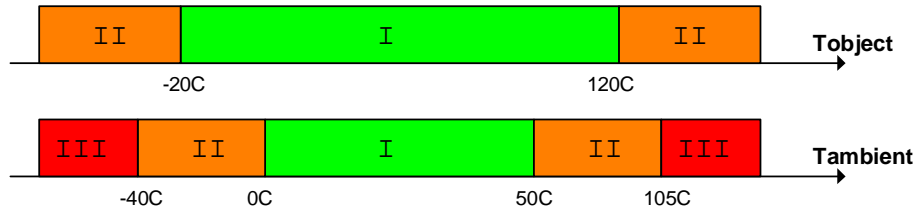

Module operating conditions

| T object in range | T ambient in range | Effect on outputs |
|-------------------|--------------------|---|
| I | I | Object temperature output is working normal Ambient temperature output is working normal |
| II | I | Object temperature output duty cycle will be 12.5% if $T_o < -20C$, or 62.5% if $T_o > 120C$. Ambient temperature output is working normal |
| I or II | II | BOTH temperature outputs duty cycle will be 68.75% if $T_a < 0C$, or 75% if $T_a > 50C$. |
| I or II | III | The module may be damaged if operated outside the ambient temperature range. BOTH temperature outputs duty cycle will be 68.75% if $T_a < 0C$, or 75% if $T_a > 50C$. |

8.3 Physical outline

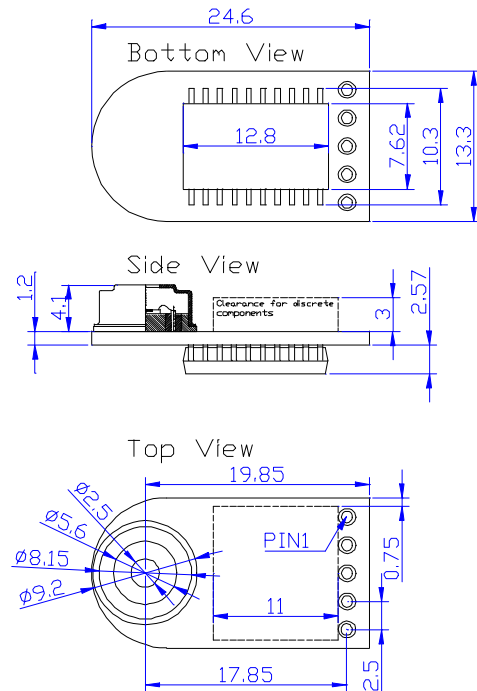

8.4 Pin-out and pin descriptions

| pin-out information | | |
|---------------------|------|---------------------------------|
| pin | Name | function |
| 1 | | PWM output infrared temperature |
| 2 | | PWM output ambient temperature |
| 3 | | Supply voltage |
| 4 | | Relay output |
| 5 | | Ground connection |

- IROUT** IROUT PWM coded output pin. The duty cycle of the signal on this pin is a linear representation of Tobject, the temperature of the object the IR sensor is pointed at.
- TEMPOUT** Tempout PWM coded output pin. The duty cycle of the signal on this pin is a linear representation of Tambient, the temperature of the IR sensor, as measured by the PTC inside MLX90247.
- VDD** Supply pin
- REL1** Open drain relay driver output. The typical on-resistance of this driver is <10 Ohms.

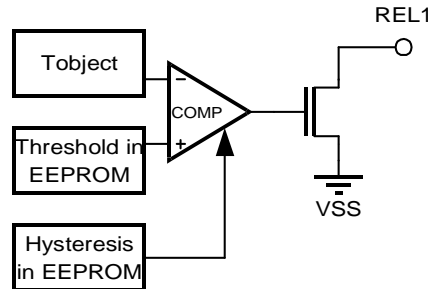

The comparator is a digital comparator, with a resolution of 12 bits. By default the input polarity is inverting. Threshold and hysteresis values are version dependent. These settings can be changed by factory programming on request. Refer to calibration settings for factory preset values.

- VSS** Supply pin (0V)

8.5 Electrical specifications

| Parameter | symbol | condition | min | typ | max | unit |
|------------------------------|--------|-----------|-------|-------|--------|------|
| Supply Voltage | | | | | | |
| Supply voltage range | VDD | | 4.75 | 5 | 6 | V |
| Power consumption | IDD | Ta=25C | | 5 | 5.6 | mA |
| outputs IROUT/TEMPOUT | | | | | | |
| PWM modulator resolution | | | | 10 | | bits |
| PWM Clock period | Tclk | | 45 | 50 | 55 | µs |
| PWM Total period | T | | 92.16 | 102.4 | 112.64 | ms |
| Leading buffer time | t1 | % of T | | 12.5 | | % |
| Trailing buffer time | t5 | % of T | | 12.5 | | % |
| Duty cycle high | t2 | % of T | 0 | | 50 | % |



| Parameter | symbol | condition | min | typ | max | unit |
|-------------------------------------|--------|------------------|------|-----|-----|------|
| Duty cycle low | t3 | % of T | 0 | | 50 | % |
| Error signal | t4 | % of T | | 25 | | % |
| Rise time* | | 10% to 90% of Vh | 13.3 | | 100 | μs |
| Fall time* | | 90% to 10% of Vh | 13.3 | | 100 | μs |
| Output voltage high | Vh | Ihigh=2mA | 4 | | | V |
| Output voltage low | VI | Ilow=2mA | | | 1 | V |
| Rel1 open drain relay driver | | | | | | |
| output impedance | Ro | | | 10 | | Ohms |
| High voltage protections | | | 32 | | | V |

* no external load

8.6 Calibration details

| | |
|--|-----------|
| Maximum calibrated object temperature | 120°C |
| Minimum calibrated object temperature | -20°C |
| Object temperature Accuracy | ±2°C |
| Maximum calibrated ambient temperature | 50°C |
| Minimum calibrated ambient temperature | 0°C |
| Ambient temperature Accuracy | ±1°C |
| Response time | 500ms |
| REL1 source | Tobject |
| REL1 polarity (*) | Inverting |
| REL1 threshold | 50°C |
| REL1 hysteresis | 5°C |
| Emissivity | 0.99 |

Note: Comparator polarity:

Inverting: relay switches OFF if temperature is above the threshold.

Non-inverting: relay switches ON if temperature is above the threshold.

8.7 Applications information

Connection of the MLX90601 module into an application is. The 5V regulated supply should be connected between pin 3 (VDD) and pin 5 (VSS).

In an actual application the module outputs can be directly connected to a timer or IRQ inputs of a microcontroller. In many applications, the ambient temperature of the sensor is not needed. In this case, pin 2 can simply be left open.

The REL1 signal at pin 4 can be used as input for a digital I/O or to drive a relay (not shown). In case of a digital input the microcontroller must have internal pull-up resistors or an external pull-up resistor must be added.

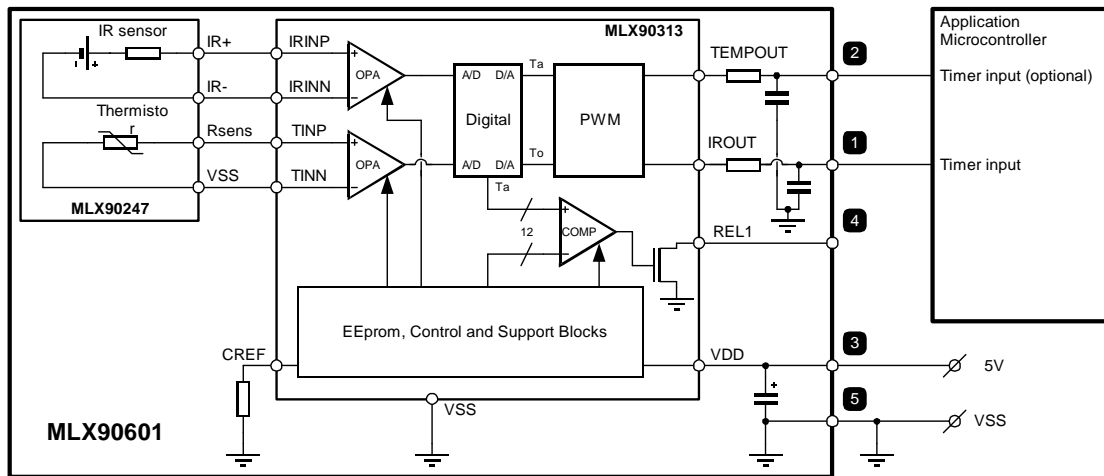

9 MLX90601EZA-CAA

9.1 Key properties

- consumer and industrial use
- PWM output signals with 10 bit resolution
- SPI interface available
- relay comparator and reference voltage
- 10 pole, mating to 1mm pitch flat cable connector

9.2 General description

The MLX90601EZA-CAA is a module that is targeted for industrial and consumer products use. The sensor and the MLX90313 ASIC are placed on a rigid PCB. The module has a 10 pole connector, which has all relevant interconnections to the ASIC. There are 2 temperature signals which are preset to provide digital PWM code output signals. The resolution of the Pulse Width Modulated output is 10 bits. Next to the temperature information these outputs can also flag ambient temperature underflow and overflow. The module has an on-board ECC (EEPROM consistency check), that checks the stored calibration constants and settings. In case of failure, the output will flag this condition.

If the ambient temperature is out of the calibrated temperature range, both PWM signals will flag this condition, and the object and ambient temperatures will not be available until the ambient temperature is back in the calibrated temperature range.

The CAA type module has the SPI interface available. Next to reading the temperature information, the SPI interface also allows changing the module's settings and calibration.

Next to the temperature outputs and SPI interface there is also a relay driver output. The relay driver has a threshold that is pre-set to 50°C, with a hysteresis of 5°C.

The PWM coding format is depicted below

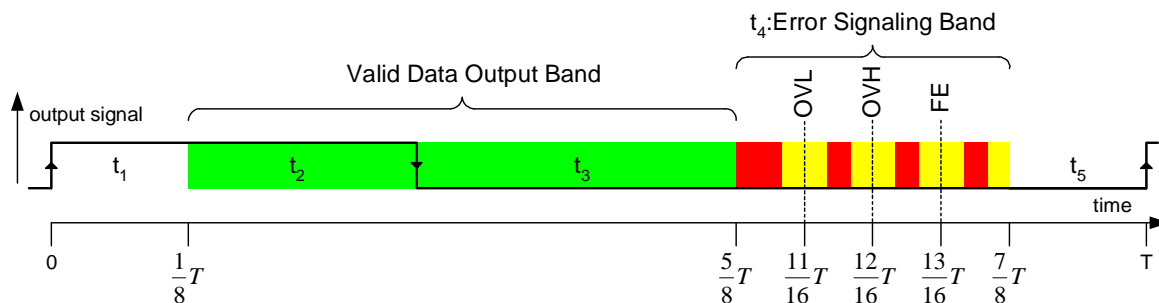

The PWM signal has a period of 102.4ms typical consisting of 2048 clock cycles of 50µs. Every frame starts with a leading buffer time, t_1 , during which the signal is always high, as shown in the figure. The leading buffer time is followed by a slot for the useful data signal starting at $1/8T$ ending at $5/8T$, where the ratio $t_2/(t_2+t_3)$ is the representation of the output value. t_4 is a slot for signaling of special conditions, such as out of range measurement of the sensor temperature, $T_{ambient}$ and the occurrence of a fatal EEPROM error, i.e. an error that can no longer be corrected automatically by the ECC circuitry of MLX90313.

PWM duty cycle overview

| Condition | Duty cycle | nominal timing |
|-------------------------|---------------|-----------------|
| Normal operation | 12.5% - 62.5% | 12.8 ms - 64 ms |
| OVL: Tambient underflow | 68.75 % | 70.4 ms |
| O VH: Tambient overflow | 75 % | 76.8 ms |
| FE: Fatal Error EEPROM | 81.25% | 83.2 ms |

The relation of the output voltage to the temperature is defined as follows:

$$T = \frac{DutyCycle - 12.5\%}{50\%} * (T_{max} - T_{min}) + T_{min}$$

where:

- T measured temperature
 - $DutyCycle$ Duty Cycle of the IROUT or TEMPOUT PWM signals.
 - T_{min} minimal calibrated temperature
 - T_{max} maximum calibrated temperature
- Refer to calibration details for calibrated ranges info

A graphical representation is depicted below.

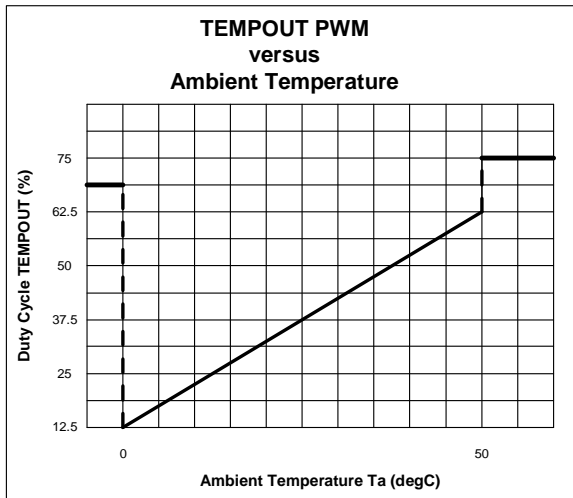
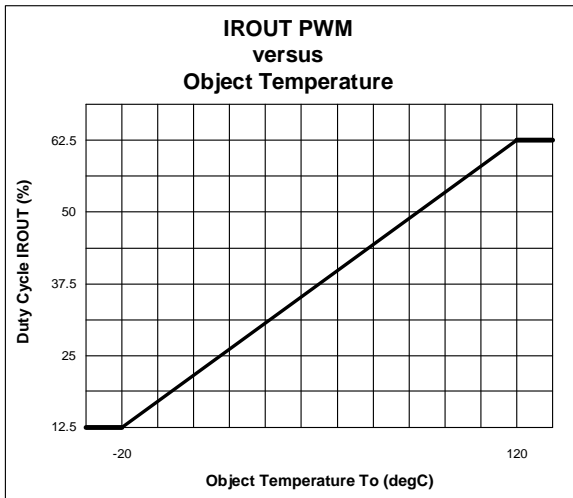

The behavior of the module outside the calibrated ranges is shown below:

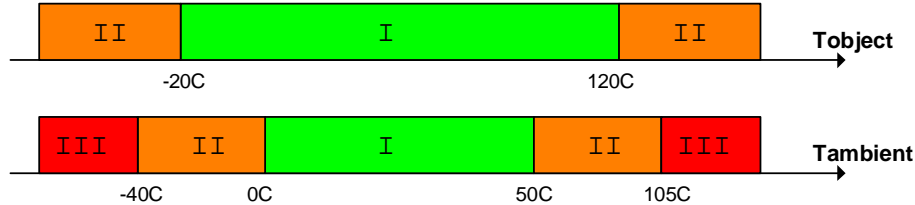

Module operating conditions

| T object in range | T ambient in range | Effect on outputs |
|-------------------|--------------------|--|
| I | I | Object temperature output is working normal Ambient temperature output is working normal |
| II | I | Object temperature output duty cycle will be 12.5% if $T_o < -20C$, or 62.5% if $T_o > 120C$. Ambient temperature output is working normal SPI IROUT register data bits 0x000 if $T_o < -20C$, or 0xFFFF if $T_o > 120C$. SPI TOUT register operating normal |
| I | II | BOTH temperature outputs duty cycle will be 68.75% if $T_a < 0C$, or 75% if $T_a > 50C$. SPI IROUT register data bits 0x000 if $T_a < 0C$, or 0xFFFF if $T_a > 50C$. Corresponding overflow flags will be set. |
| I | III | The module may be damaged if operated outside the ambient temperature range. BOTH temperature outputs duty cycle will be 68.75% if $T_a < 0C$, or 75% if $T_a > 50C$. SPI IROUT register data bits 0x000 if $T_a < 0C$, or 0xFFFF if $T_a > 50C$. Corresponding overflow flags will be set. |

9.3 Serial Peripheral Interface (SPI)

Protocol

The digital interface implemented in MLX90313C is SPI compatible. It can be used to access the on-chip EEPROM and all internal registers. The chip will always work as a slave device. The format of any command is always 32 bits: 8 bits for the operation code, 8 bits for the address and 16 bits of data. The communication protocol is presented below.

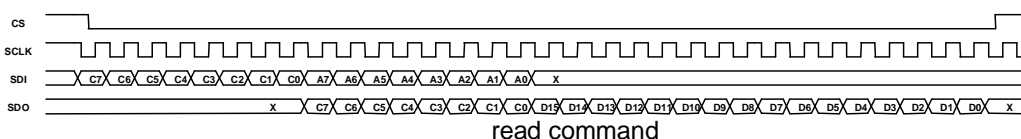
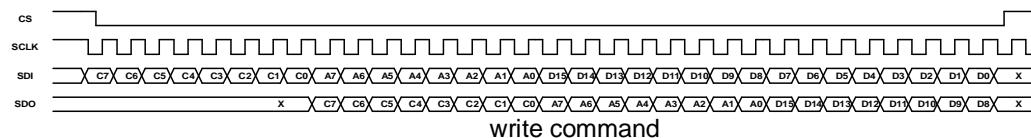

Every write command starts with a high to low transition of CS and ends by a low to high transition of CS after 32 periods of the serial data clock (SCLK). MLX90313C reads the data present on SDI on the rising edge of the clock. With a delay of 8 periods of the serial clock, the SPI will repeat the opcode, address and the first 8 bits of data on pin SDO. This allows the external master to check command and address and terminate the operation in case of an error by forcing CS high before the end of the complete command cycle, i.e. before the end of the 32 clock periods.

The read command is build up similarly, except that no data has to be passed of course. On SDO the opcode will be followed directly by the requested data, the address is not returned in this case.

The data on SDO is valid on the rising edge of the clock. In case of a read command, the SPI will output the data on SDO starting on the 25th rising edge of the clock (after CS low) as indicated in the figure above.

Timing/speed

The baud-rate depends on the serial data clock (SCLK) supplied by the master controller and is limited to 125kb/s. The timing requirements are given in the figure and table below

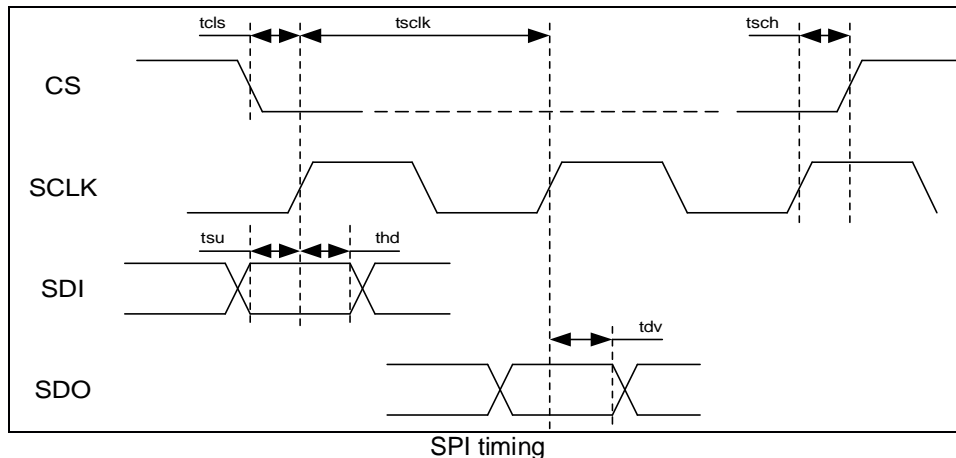

SPI timing requirements

| Symbol | Parameter | Value | Unit |
|--------|---------------------|---------|------|
| tsck | Sclk period | min 8 | µs |
| tcls | CS low to SCLK high | min 50 | ns |
| tsch | SCLK low to CS high | min 50 | ns |
| tsu | data in setup time | min 200 | ns |
| thd | data in hold time | min 200 | ns |
| tdv | data out valid | min 1 | µs |

operation codes

The operation code is the first series of 8bits in a command, C[7:0] in the figure on the protocol above. Below table summarizes the operations available in MLX90313C.

| Operation Codes | | |
|-----------------|----------|-------------------------|
| mnem. | C[7:0] | Command |
| WR | x101x0xx | Write internal register |



| | | |
|------|----------|------------------------|
| RD | x10010XX | Read internal register |
| WEPR | 0001XXXX | Write EEPROM |
| ER | 001XXXXX | Erase EEPROM |
| REPR | x0001XXX | Read EEPROM |
| BLWR | 1001XXXX | Block Write EEPROM |
| BLER | 101XXXXX | Block erase EEPROM |

Temperature registers

The object and ambient temperatures are stored into internal registers. A table containing the most interesting internal register addresses is included below:

| Register | Function | Address |
|----------|----------------|---------|
| lout | Tobject (lin) | 09h |
| Tout | Tambient (lin) | 0Ah |

These registers keep the linearised object and ambient temperature.

Register format:

| Bit | 15 | 14 | 13 | 12 | 11 | 10 | 9 | 8 | 7 | 6 | 5 | 4 | 3 | 2 | 1 | 0 |
|------|-----|-----|----|----|----|----|----|----|----|----|----|----|-----|-----|----|-----|
| Name | D11 | D10 | D9 | D8 | D7 | D6 | D5 | D4 | D3 | D2 | D1 | D0 | OVH | OVL | FE | Res |

- D11..D0 : 12 bit temperature data
- OVH: Overflow flag for Tambient measurement, Ta>Tamax, D[11:0] set to FFFh
- OVL: Underflow flag for Tambient measurement, Ta<Tamin, D[11:0] set to 000h
- FE: Fatal Error in EEPROM.
- Res: Not used, always zero.

The measured temperature can be obtained from the register content as follows:

$$T = \frac{Rt}{2^{12} - 1} (Tmax - Tmin) + Tmin$$

Where:

- Rt register value (12 bit, 0x000 to 0xFFFF)
- Tmax maximum calibrated temperature
- Tmin minimum calibrated temperature

EEPROM reprogramming

Every MLX90601 module has 8 words of 16bits of EEPROM space free to use for the user. One can freely use this memory space for serialization or storing some other info. Also, in some cases it is necessary to redefine functionality of the MLX90601 infrared module. The configuration constants are stored in EEPROM non-volatile memory. Note that also the linearization constants are stored in EEPROM, and erasing or over-writing these will irreversibly destroy the modules' proper operation. Reprogramming the EEPROM must be done with care.

Here's how to rewrite a specific EEPROM address.

1. Write 0xB200 to register address 0x10. This unlocks EEPROM control registers. The module now stops updating its output
2. Write 0x0065 to register address 0x18. Enables charge pump for programming.



3. Erase the address you want to rewrite
4. Write the new data in the EEPROM address
5. Repeat steps 3 and 4 for any further programming
6. You now can cycle the power for restarting the chip in normal operation, with new settings

Be sure never to use the Block Write or Block Erase commands, as they completely erase the EEPROM. For further details please refer to MLX90313 datasheet.

9.4 Physical outline

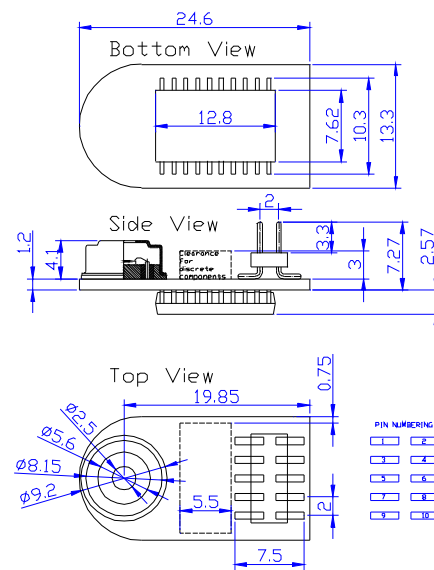
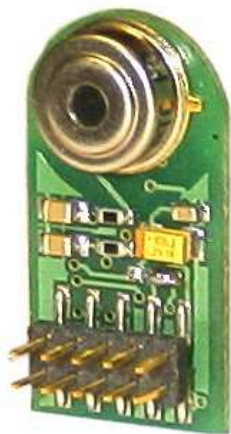

9.5 Pin-out and pin descriptions

| pin-out information | | |
|---------------------|---------|---------------------------------------|
| pin | name | Function |
| 1 | REL1 | Relay output |
| 2 | VSS | Ground connection |
| 3 | VDD | Supply voltage |
| 4 | SDIN | SPI data in |
| 5 | SDOUT | SPI data out |
| 6 | CSB | SPI chip select |
| 7 | SCLK | SPI clock |
| 8 | IROUT | PWM coded output infrared temperature |
| 9 | VREF | Reference voltage output |
| 10 | TEMPOUT | PWM coded output ambient temperature |

REL1 Open drain relay driver output. The typical on-resistance of this driver is <10 Ohms.

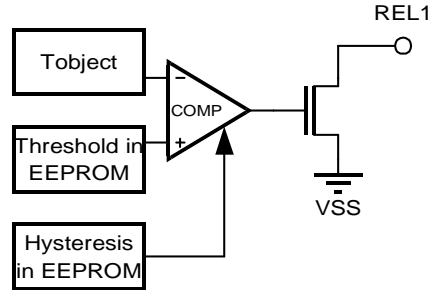

The comparator is a digital comparator, with a resolution of 12 bits. By default the input polarity is inverting. Threshold and hysteresis values are version dependent. These settings can be changed by factory programming on request. Refer to calibration settings for factory preset values.

- VSS Supply pin (0V)
- VDD Supply pin
- SDIN SPI data input
- SDOUT SPI data output
- CSB SPI chip select. Active low.
- SCLK SPI clock line
- IROUT IROUT PWM coded output pin. The duty cycle of the signal on this pin is a linear representation of Tobject, the temperature of the object the IR sensor is pointed at.
- VREF DAC reference voltage. This voltage must be used if the module is used as a thermostat using the REL1 comparator with external threshold.
- TEMPOUT Tempout PWM coded output pin. The duty cycle of the signal on this pin is a linear representation of Tambient, the temperature of the IR sensor, as measured by the PTC inside MLX90247.

9.6 Electrical specifications

| Parameter | symbol | condition | min | typ | max | unit |
|------------------------------|--------|------------------|-------|-------|--------|------|
| Supply Voltage | | | | | | |
| Supply voltage range | VDD | | 4.75 | 5 | 6 | V |
| Power consumption | IDD | Ta=25C | | 5 | 5.6 | mA |
| outputs IROUT/TEMPOUT | | | | | | |
| PWM modulator resolution | | | | 10 | | bits |
| PWM Clock period | Tclk | | 45 | 50 | 55 | µs |
| PWM Total period | T | | 92.16 | 102.4 | 112.64 | ms |
| Leading buffer time | t1 | % of T | | 12.5 | | % |
| Trailing buffer time | t5 | % of T | | 12.5 | | % |
| Duty cycle high | t2 | % of T | 0 | | 50 | % |
| Duty cycle low | t3 | % of T | 0 | | 50 | % |
| Error signal | t4 | % of T | | 25 | | % |
| Rise time* | | 10% to 90% of Vh | 13.3 | | 100 | µs |
| Fall time* | | 90% to 10% of Vh | 13.3 | | 100 | µs |
| Output voltage high | Vh | Ihigh=2mA | 4 | | | V |
| Output voltage low | VI | Ilow=2mA | | | 1 | V |



| Parameter | symbol | condition | min | typ | max | unit |
|-------------------------------------|--------|-----------|-----|-----|-----|------|
| Rel1 open drain relay driver | | | | | | |
| output impedance | Ro | | | 10 | | Ohms |
| High voltage protections | | | 32 | | | V |

9.7 Calibration details

| | |
|--|-----------|
| Maximum calibrated object temperature | 120°C |
| Minimum calibrated object temperature | -20°C |
| Object temperature Accuracy | ±2°C |
| Maximum calibrated ambient temperature | 0°C |
| Minimum calibrated ambient temperature | 50°C |
| Ambient temperature Accuracy | ±1°C |
| Response time | 500ms |
| REL1 source | Tobject |
| REL1 polarity (*) | Inverting |
| REL1 threshold | 50°C |
| REL1 hysteresis | 5°C |
| Emissivity | 0.99 |

Note: Comparator polarity:

Inverting: relay switches OFF if temperature is above the threshold.

Non-inverting: relay switches ON if temperature is above the threshold.

9.8 Applications information

Connection of the MLX90601EZA-CAA module into an application is straightforward. The 5V regulated supply should be connected between pin 3 (VDD) and pin 2 (VSS). There are numerous possibilities for the I/O of which one example is shown below. Here the default configuration is used. In the example a relay is switched with the REL1 output. The threshold for this comparator is programmed in the EEPROM. This means the microcontroller can change the threshold, and the MLX90601 can control the alarm standalone. The SPI connection to the host microcontroller can be a permanent connection in the application or just a means for in-circuit programming of the device. Through this connection full access to the internal registers and configuration settings is achieved. The SPI connection can also be used to directly read output data from the module in digital form and process this directly in the application. An interesting feature is in-circuit programming of the calibration constants. It is possible to change the range or emissivity, or whatever setting needs to be user adjustable.

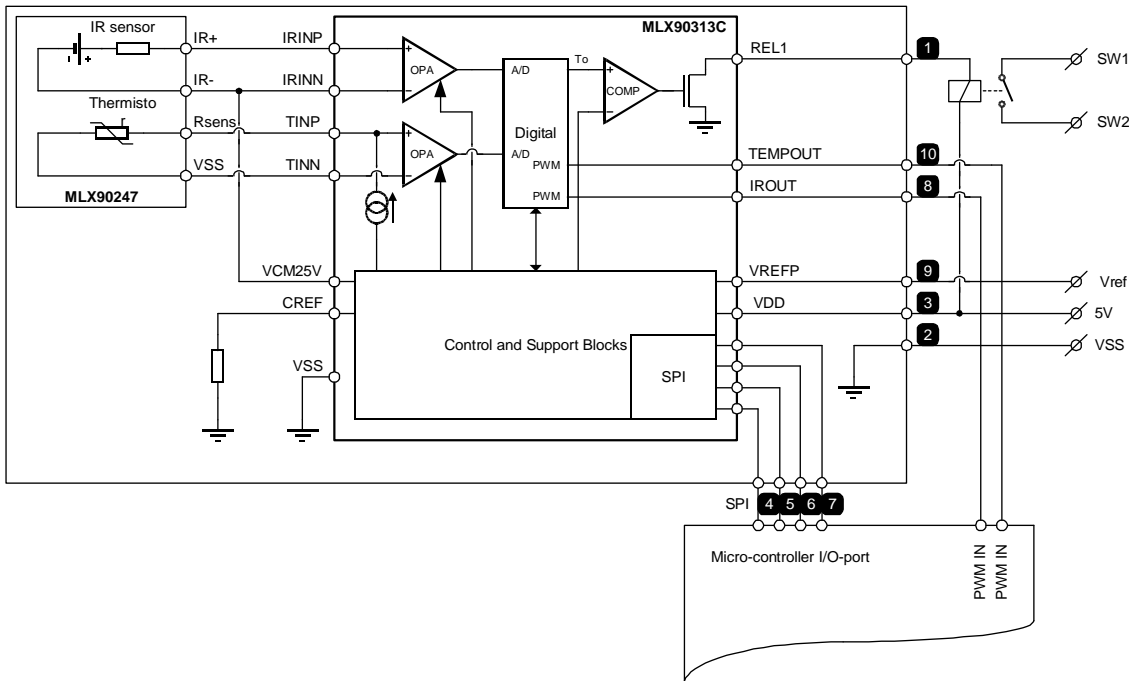

10 MLX90601KZA-BKA

10.1 Key properties

- Flex circuit for consumer and industrial use.
- analog output signals with 8 bit resolution
- SPI interface available
- relay comparator and reference voltage
- 10 pole flex connector

10.2 General description

The MLX90601KZA-BKA is a module that is targeted for industrial and consumer products use. The sensor and the MLX90313 ASIC are placed on a flexible substrate. This allows the sensor to be bent in any direction. This may greatly simplify fitting in the module into the application. The module has a 10 pole connector, which has all relevant interconnections to the ASIC. There are 2 temperature signals which are preset to provide analog output voltage. The Object temperature information is available at the IROUT pin. The ambient temperature information is available on the TEMPOUT pin. The resolution of the output D/A converter is 8bit. The output drivers have a maximum output voltage of 4.5V when the maximum calibrated temperature is reached.

If the ambient temperature is out of the calibrated temperature range, the correct object temperature cannot be calculated. For applications where the ambient temperature can rise above the maximum calibrated temperature, the ambient temperature output must be monitored to make sure the object temperature is valid.

The flex modules all have the SPI interface available. Next to reading the temperature information, the SPI interface also allows changing the module's settings and calibration.

The temperature as read by the SPI interface will not be equal to the temperature presented at the analog outputs. Refer to SPI interface description for details.

Next to the temperature outputs there is also a relay driver output. The relay driver has a threshold that is pre-set to 95°C, with a hysteresis of 5°C.

The relation of the output voltage to the temperature is defined as follows:

$$T = \frac{V_{out}}{4.5} * (T_{max} - T_{min}) + T_{min}$$

Where:

- T measured temperature
 - V_{out} analog output voltage on IROUT or TEMPOUT pins.
 - T_{min} minimal calibrated temperature
 - T_{max} maximum calibrated temperature
- Refer to calibration details for calibrated ranges info

A graphical representation is depicted below.

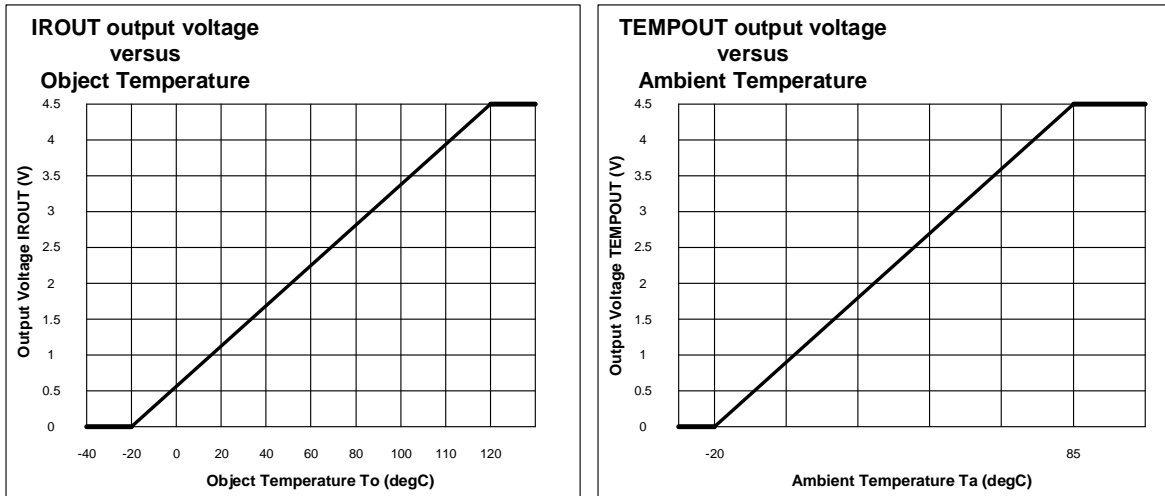

The behavior of the module outside the calibrated ranges is shown below:

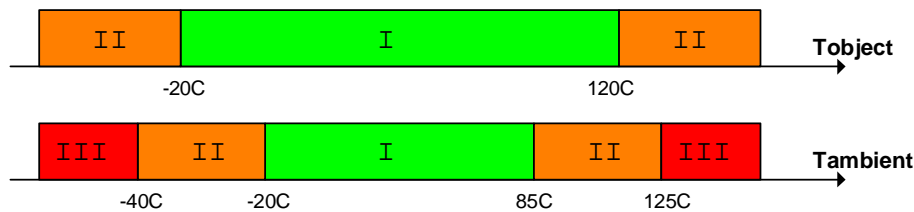

Module operating conditions

| T object in range | T ambient in range | Effect on outputs |
|-------------------|--------------------|--|
| I | I | Object temperature output is working normal Ambient temperature output is working normal |
| II | I | Object temperature output will be clamped at 0V ($T_o < -20C$) or clamped at 4.5V ($T_o > 120C$). Ambient temperature output is working normal SPI IROUT register data bits 0x000 if $T_o < -20C$, or 0xFFFF if $T_o > 120C$. SPI TOUT register operating normal |
| I or II | II | BOTH temperature outputs will be clamped 0V ($T_a < -20C$) or clamped at 4.5V ($T_a > 85C$). SPI IROUT register data bits 0x000 if $T_a < -20C$, or 0xFFFF if $T_a > 85C$. Corresponding overflow flags will be set. |
| I or II | III | The module may be damaged if operated outside the ambient temperature range. BOTH temperature outputs will be clamped 0V ($T_a < -20C$) or clamped at 4.5V ($T_a > 85C$). SPI IROUT register data bits 0x000 if $T_a < -20C$, or 0xFFFF if $T_a > 85C$. Corresponding overflow flags will be set. |



10.3 Serial Peripheral Interface (SPI)

Protocol

The digital interface implemented in MLX90313C is SPI compatible. It can be used to access the on-chip EEPROM and all internal registers. The chip will always work as a slave device. The format of any command is always 32 bits: 8 bits for the operation code, 8 bits for the address and 16 bits of data. The communication protocol is presented below.

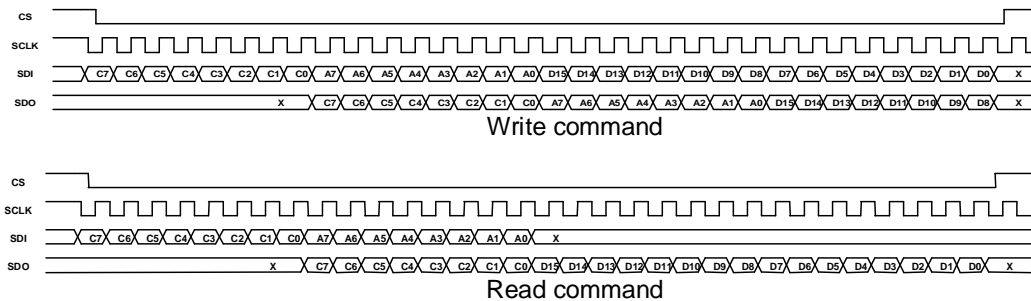

Every write command starts with a high to low transition of CS and ends by a low to high transition of CS after 32 periods of the serial data clock (SCLK). MLX90313C reads the data present on SDI on the rising edge of the clock. With a delay of 8 periods of the serial clock, the SPI will repeat the opcode, address and the first 8 bits of data on pin SDO. This allows the external master to check command and address and terminate the operation in case of an error by forcing CS high before the end of the complete command cycle, i.e. before the end of the 32 clock periods.

The read command is build up similarly, except that no data has to be passed of course. On SDO the opcode will be followed directly by the requested data, the address is not returned in this case.

The data on SDO is valid on the rising edge of the clock. In case of a read command, the SPI will output the data on SDO starting on the 25th rising edge of the clock (after CS low) as indicated in the figure above.

Timing/speed

The baud-rate depends on the serial data clock (SCLK) supplied by the master controller and is limited to 125kb/s. The timing requirements are given in the figure and table below

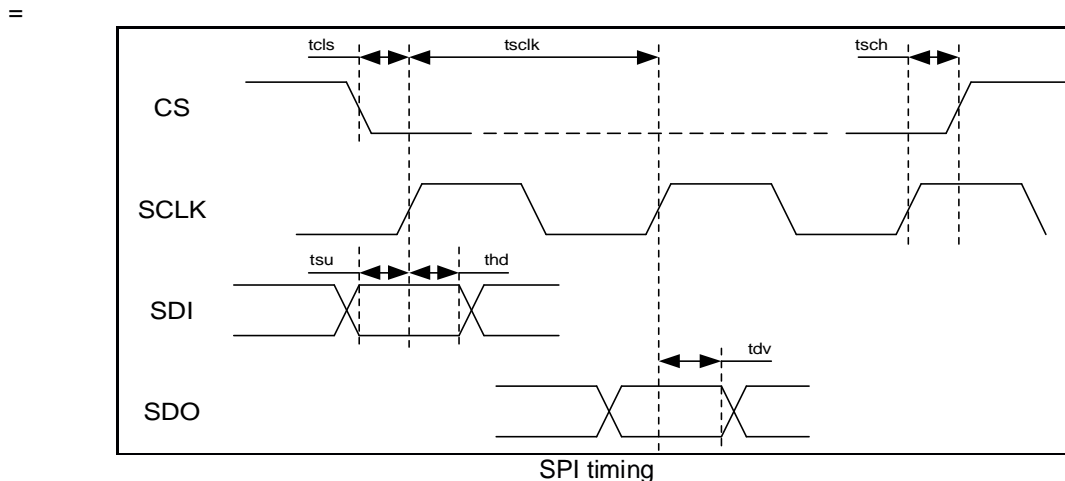

SPI timing requirements

| Symbol | Parameter | Value | Unit |
|--------|---------------------|---------|------|
| tclk | Sclk period | min 8 | µs |
| tcls | CS low to SCLK high | min 50 | ns |
| tsch | SCLK low to CS high | min 50 | ns |
| tsu | data in setup time | min 200 | ns |
| thd | data in hold time | min 200 | ns |
| tdv | data out valid | min 1 | µs |

operation codes

The operation code is the first series of 8bits in a command, C[7:0] in the figure on the protocol above. Below table summarizes the operations available in MLX90313C.

Operation Codes

| mnem. | C[7:0] | Command |
|-------|----------|-------------------------|
| WR | x101x0xx | Write internal register |
| RD | x10010xx | Read internal register |
| WEPR | 0001xxxx | Write EEPROM |
| ER | 001xxxxx | Erase EEPROM |
| REPR | x0001xxx | Read EEPROM |
| BLWR | 1001xxxx | Block Write EEPROM |
| BLER | 101xxxxx | Block erase EEPROM |

Temperature registers

The object and ambient temperatures are stored into internal registers. A table containing the most interesting internal register addresses is included below:

Address list internal registers

| Register | Function | Address |
|----------|----------------|---------|
| Irout | Tobject (lin) | 09h |
| Tout | Tambient (lin) | 0Ah |

These registers keep the linearised object and ambient temperature.

Register format:

| Bit | 15 | 14 | 13 | 12 | 11 | 10 | 9 | 8 | 7 | 6 | 5 | 4 | 3 | 2 | 1 | 0 |
|------|-----|-----|----|----|----|----|----|----|----|----|----|----|-----|-----|----|-----|
| Name | D11 | D10 | D9 | D8 | D7 | D6 | D5 | D4 | D3 | D2 | D1 | D0 | OVH | OVL | FE | Res |

- D11..D0 : 12 bit temperature data
- OVH: Overflow flag for Tambient measurement, Ta>Tamax, D[11:0] set to FFFh
- OVL: Underflow flag for Tambient measurement, Ta<Tamin, D[11:0] set to 000h
- FE: Fatal Error in EEPROM.
- Res: Not used, always zero.

The MLX90601 KZA-BKA has been calibrated to have absolute voltage outputs. Therefore there is a difference between the temperature information of the analog outputs and the internal register values.



Before calculation of the temperature for the internal register content is possible, it is necessary to measure the VREF voltage, available at pin 5. This voltage will be slightly different for each module so it must be measured for every module. A correction factor must be included in the calculation.

The measured temperature can be obtained from the register content as follows:

$$T = \frac{R_t * \frac{V_{ref}}{4.5}}{2^{12} - 1} \bullet (T_{max} - T_{min}) + T_{min}$$

Where:

T measured temperature
 R_t register value (12 bit, 0x000 to 0xFFF)
 V_{ref} Reference voltage (to be measured)
 T_{max} maximum calibrated temperature
 T_{min} minimum calibrated temperature

EEPROM reprogramming

Every MLX90601 module has 8 words of 16bits of EEPROM space free to use for the user. One can freely use this memory space for serialization or storing some other info. Also, in some cases it is necessary to redefine functionality of the MLX90601 infrared module.

The configuration constants are stored in EEPROM non-volatile memory. Note that also the linearization constants are stored in EEPROM, and erasing or over-writing these will irreversibly destroy the modules' proper operation. Reprogramming the EEPROM must be done with care.

Here's how to rewrite a specific EEPROM address.

7. Write 0xB200 to register address 0x10. This unlocks EEPROM control registers. The module now stops updating its output
8. Write 0x0065 to register address 0x18. Enables charge pump for programming.
9. Erase the address you want to rewrite
10. Write the new data in the EEPROM address
11. Repeat steps 3 and 4 for any further programming
12. You now can cycle the power for restarting the chip in normal operation, with new settings

Be sure never to use the Block Write or Block Erase commands, as they completely erase the EEPROM. For further details please refer to MLX90313 datasheet.

10.4 Physical outline

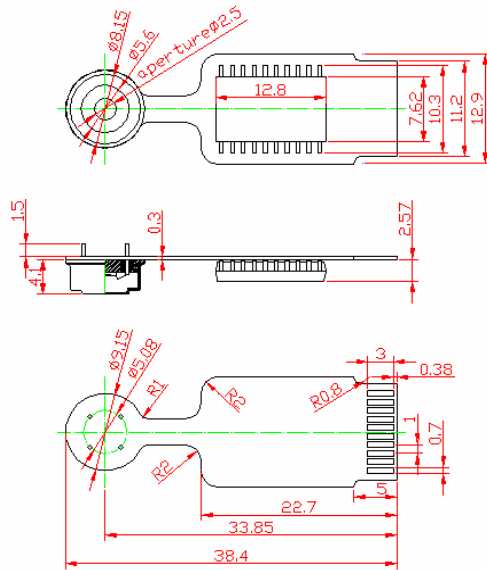

10.5 Pin-out and pin descriptions

| pin-out information | | |
|---------------------|---------|------------------------------------|
| pin | name | function |
| 1 | VSS | Ground connection |
| 2 | REL1 | Relay output |
| 3 | IROUT | analog output infrared temperature |
| 4 | TEMPOUT | analog output ambient temperature |
| 5 | VREF | Reference voltage output |
| 6 | VDD | Supply voltage |
| 7 | SDIN | SPI data in |
| 8 | SCLK | SPI clock |
| 9 | SDOUT | SPI data out |
| 10 | CSB | SPI chip select |

VSS Supply pin (0V)

REL1 Open drain relay driver output. The typical on-resistance of this driver is <10 Ohms.

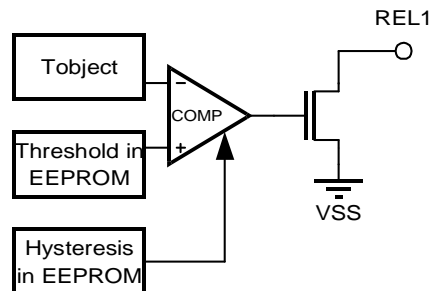

The comparator is a digital comparator, with a resolution of 12 bits. By default the input

polarity is inverting. Threshold and hysteresis values are version dependent. These settings can be changed by factory programming on request. Refer to calibration settings for factory preset values.

- IROUT IROUT analog voltage output pin. The voltage at this pin is a linear representation of Tobject, the temperature of the object the IR sensor is pointed at.
- TEMPOUT Ambient temperature analog voltage output pin. The voltage at this pin is a linear representation of Tambient, the temperature of the IR sensor, as measured by the PTC inside MLX90247.
- VREF DAC reference voltage. This voltage must be used if the module is used as a thermostat using the REL1 comparator with external threshold.
- VDD Supply pin
- SDIN SPI data input
- SCLK SPI clock line
- SDOUT SPI data output
- CSB SPI chip select. Active low.

10.6 Electrical specifications

| Parameter | symbol | condition | min | typ | max | unit |
|-------------------------------------|--------|---------------------------------|------|-----|-----|------|
| Supply Voltage | | | | | | |
| Supply voltage range | VDD | | 4.75 | 5 | 6 | V |
| Power consumption | IDD | Ta=25C | | 5 | 5.6 | mA |
| analog outputs IROUT/TEMPOUT | | | | | | |
| D/A converter resolution | | | | 8 | | Bits |
| Output source current | Iod | | 1 | | | mA |
| Output sink current | Ios | | 20 | | | uA |
| AC Output impedance | ro | | | | 100 | Ω |
| Capacitive load | Cmax | directly on pin | | | 50 | pF |
| Capacitive load | | with 200 ohms series resistance | | | 100 | nF |
| Rel1 open drain relay driver | | | | | | |
| output impedance | Ro | | | 10 | | Ohms |
| High voltage protections | | | 32 | | | V |

When the Cmax value is exceeded, a series resistor must be used to maintain stability.

10.7 Calibration details

| | |
|--|-----------|
| Maximum calibrated object temperature | 120°C |
| Minimum calibrated object temperature | -20°C |
| Object temperature Accuracy | ±2°C |
| Maximum calibrated ambient temperature | -20°C |
| Minimum calibrated ambient temperature | 85°C |
| Ambient temperature Accuracy | ±1°C |
| Response time | 500ms |
| REL1 source | Tobject |
| REL1 polarity (*) | Inverting |
| REL1 threshold | 95°C |
| REL1 hysteresis | 5°C |
| Emissivity | 0.99 |



Note: Comparator polarity:
 Inverting: relay switches OFF if temperature is above the threshold.
 Non-inverting: relay switches ON if temperature is above the threshold.

10.8 Applications information

Connection of the MLX90601 module into an application is straightforward. The 5V regulated supply should be connected between pin 6 (VDD) and pin 1 (VSS). The outputs can be measured relative to VSS at pin 3 (IROUT) for Tobject and pin 4 (TEMPOUT) for Tambient, e.g. by means of a voltmeter. In an actual application the module outputs can be directly connected to the A/D inputs of a microcontroller, e.g. as a replacement for a conventional temperature sensor. When large loading capacitances are to be used, a series resistor may be necessary. Refer to electrical specifications.

Although the circuit carrier is flexible, it is only intended to be bent at the neck between the thermopile sensor and the ASIC. Minimal bending radius is 1.5mm.

In many applications, the ambient temperature of the sensor is not needed. In this case, pin 2 can simply be left open. The REL1 signal can be used as input for a digital I/O or to drive a relay (not shown). In case of a digital input the microcontroller must have internal pull-up resistors or an external pull-up resistor must be added. Here of course the microcontroller connection to the SPI interface is purely optional.

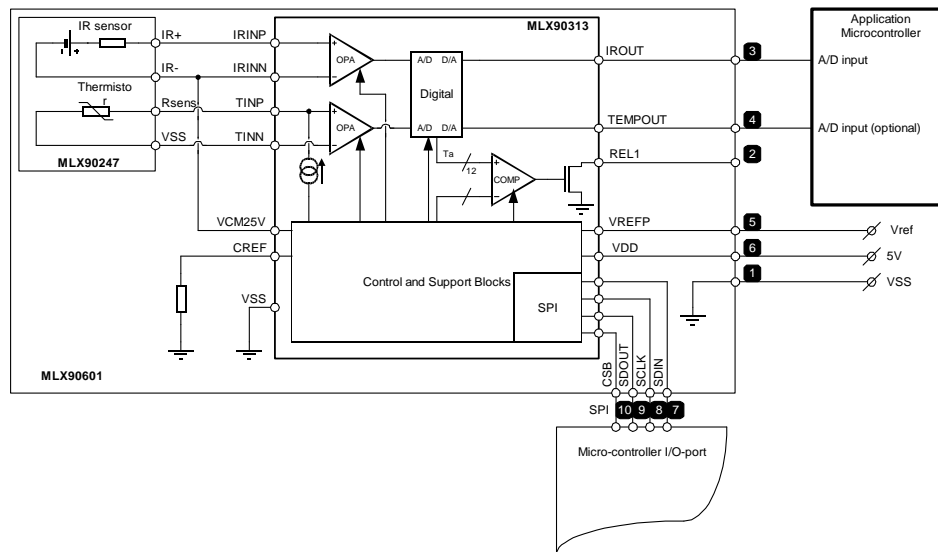

11 MLX90601KZA-CKA

11.1 Key properties

- Flex circuit for consumer and industrial use.
- PWM output signals with 10 bit resolution
- SPI interface available
- relay comparator and reference voltage
- 10 pole flex connector

11.2 General description

The MLX90601KZA-CKA is a module that is targeted for industrial and consumer products use. The sensor and the MLX90313 ASIC are placed on a flexible substrate. This allows the sensor to be bent in any direction. This may greatly simplify fitting in the module into the application. The module has a 10 pole connector, which has all relevant interconnections to the ASIC. There are 2 temperature signals which are preset to provide digital PWM code output signals. The resolution of the Pulse Width Modulated output is 10 bits. Next to the temperature information this outputs can also flag ambient temperature underflow and overflow. The module has an on-board ECC (EEPROM consistency check), that checks the stored calibration constants and settings. In case of failure, the output fill flag this condition.

If the ambient temperature is out of the calibrated temperature range, both PWM signals will flag this condition, and the object and ambient temperatures will not be available until the ambient temperature is back in the calibrated temperature range.

The flex modules all have the SPI interface available. Next to reading the temperature information, the SPI interface also allows changing the module's settings and calibration.

Next to the temperature outputs and SPI interface there is also a relay driver output. The relay driver has a threshold that is pre-set to 95°C, with a hysteresis of 5°C.

The PWM coding format is depicted below

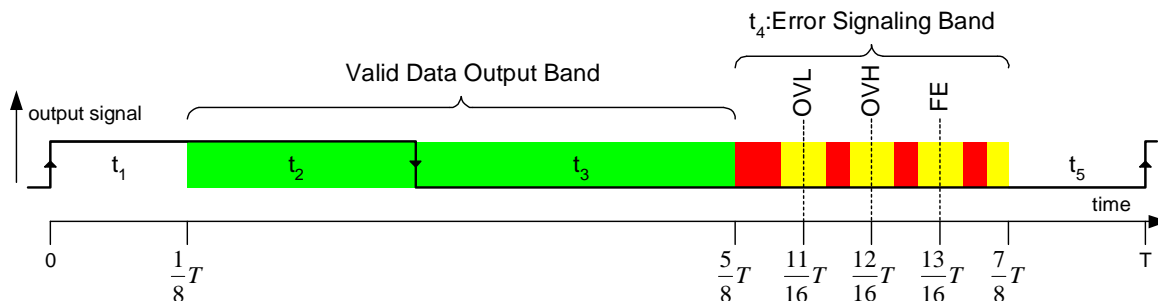

The PWM signal has a period of 102.4ms typical consisting of 2048 clock cycles of 50µs. Every frame starts with a leading buffer time, t_1 , during which the signal is always high, as shown in the figure. The leading buffer time is followed by a slot for the useful data signal starting at $1/8T$ ending at $5/8T$, where the ratio $t_2/(t_2+t_3)$ is the representation of the output value. t_4 is a slot for signaling of special conditions, such as out of range measurement of the sensor temperature, $T_{ambient}$ and the occurrence of a fatal EEPROM error, i.e. an error that can no longer be corrected automatically by the ECC circuitry of MLX90313.

PWM duty cycle overview

| Condition | Duty cycle | nominal timing |
|-------------------------|---------------|-----------------|
| Normal operation | 12.5% - 62.5% | 12.8 ms - 64 ms |
| OVL: Tambient underflow | 68.75 % | 70.4 ms |
| OVH: Tambient overflow | 75 % | 76.8 ms |
| FE: Fatal Error EEPROM | 81.25% | 83.2 ms |

The relation of the output voltage to the temperature is defined as follows:

$$T = \frac{DutyCycle - 12.5\%}{50\%} * (Tmax - Tmin) + Tmin$$

where:

- T measured temperature
 - $DutyCycle$ Duty Cycle of the IROUT or TEMPOUT PWM signals.
 - $Tmin$ minimal calibrated temperature
 - $Tmax$ maximum calibrated temperature
- Refer to calibration details for calibrated ranges info

A graphical representation is depicted below.

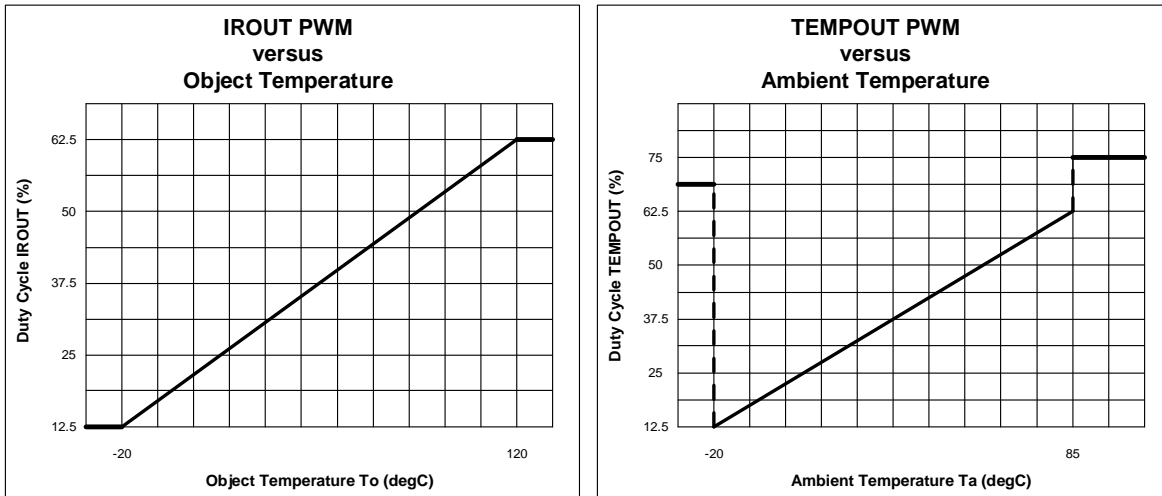

The behavior of the module outside the calibrated ranges is shown below:

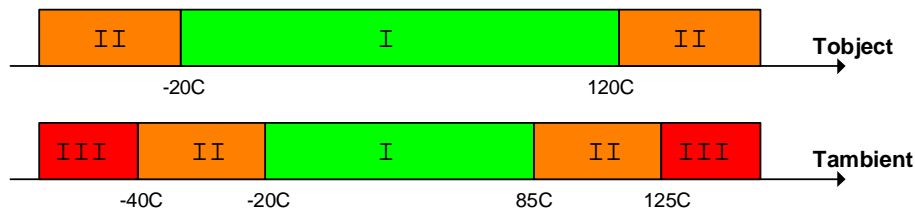

Module operating conditions

| T object in range | T ambient in range | Effect on outputs |
|-------------------|--------------------|--|
| I | I | Object temperature output is working normal Ambient temperature output is working normal |
| II | I | Object temperature output duty cycle will be 12.5% if $T_o < -20C$, or 62.5% if $T_o > 120C$. Ambient temperature output is working normal SPI IROUT register data bits 0x000 if $T_o < -20C$, or 0xFFFF if $T_o > 120C$. SPI TOUT register operating normal |
| I | II | BOTH temperature outputs duty cycle will be 68.75% if $T_a < -20C$, or 75% if $T_a > 85C$. SPI IROUT register data bits 0x000 if $T_a < -20C$, or 0xFFFF if $T_a > 85C$. Corresponding overflow flags will be set. |
| I | III | The module may be damaged if operated outside the ambient temperature range. BOTH temperature outputs duty cycle will be 68.75% if $T_a < -20C$, or 75% if $T_a > 85C$. SPI IROUT register data bits 0x000 if $T_a < -20C$, or 0xFFFF if $T_a > 85C$. Corresponding overflow flags will be set. |

11.3 Serial Peripheral Interface (SPI)

Protocol

The digital interface implemented in MLX90313C is SPI compatible. It can be used to access the on-chip EEPROM and all internal registers. The chip will always work as a slave device. The format of any command is always 32 bits: 8 bits for the operation code, 8 bits for the address and 16 bits of data. The communication protocol is presented below.

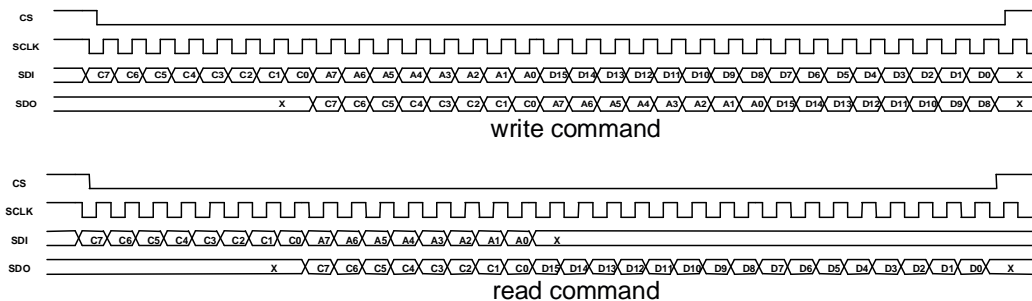

Every write command starts with a high to low transition of CS and ends by a low to high transition of CS after 32 periods of the serial data clock (SCLK). MLX90313C reads the data present on SDI on the rising edge of the clock. With a delay of 8 periods of the serial clock, the SPI will repeat the opcode, address and the first 8 bits of data on pin SDO. This allows the external master to check command and address and terminate the operation in case of an error by forcing CS high before the end of the complete command cycle, i.e. before the end of the 32 clock periods.

The read command is build up similarly, except that no data has to be passed of course. On SDO the opcode will be followed directly by the requested data, the address is not returned in this case.

The data on SDO is valid on the rising edge of the clock. In case of a read command, the SPI will output



the data on SDO starting on the 25th rising edge of the clock (after CS low) as indicated in the figure above.

Timing/speed

The baud-rate depends on the serial data clock (SCLK) supplied by the master controller and is limited to 125kb/s. The timing requirements are given in the figure and table below

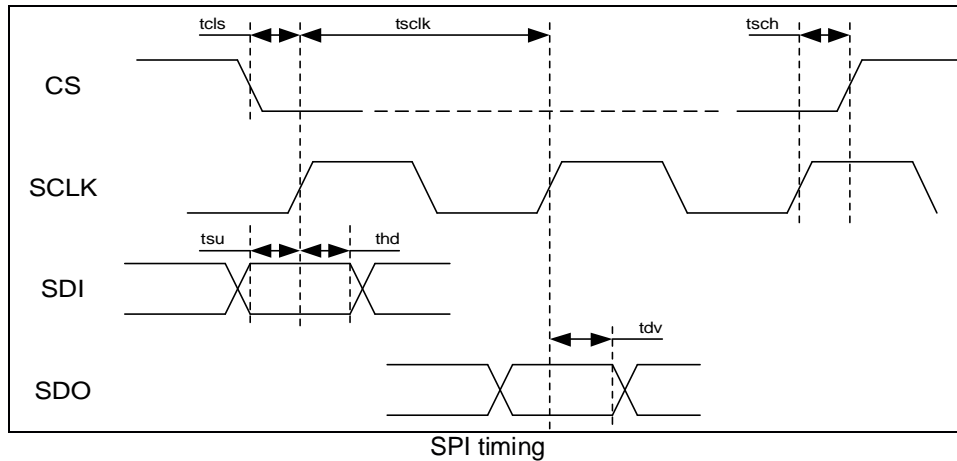

SPI timing requirements

| Symbol | Parameter | Value | Unit |
|--------|---------------------|---------|------|
| tclk | Sclk period | min 8 | μs |
| tcls | CS low to SCLK high | min 50 | ns |
| tsch | SCLK low to CS high | min 50 | ns |
| tsu | data in setup time | min 200 | ns |
| thd | data in hold time | min 200 | ns |
| tdv | data out valid | min 1 | μs |

operation codes

The operation code is the first series of 8bits in a command, C[7:0] in the figure on the protocol above. Below table summarizes the operations available in MLX90313C.

Operation Codes

| mnem. | C[7:0] | Command |
|-------|----------|-------------------------|
| WR | x101x0xx | Write internal register |
| RD | x10010xx | Read internal register |
| WEPR | 0001xxxx | Write EEPROM |
| ER | 001xxxxx | Erase EEPROM |
| REPR | x0001xxx | Read EEPROM |
| BLWR | 1001xxxx | Block Write EEPROM |
| BLER | 101xxxxx | Block erase EEPROM |



Temperature registers

The object and ambient temperatures are stored into internal registers.
A table containing the most interesting internal register addresses is included below:

Address list internal registers

| Register | Function | Address |
|----------|----------------|---------|
| Irout | Tobject (lin) | 09h |
| Tout | Tambient (lin) | 0Ah |

These registers keep the linearised object and ambient temperature.

Register format:

| Bit | 15 | 14 | 13 | 12 | 11 | 10 | 9 | 8 | 7 | 6 | 5 | 4 | 3 | 2 | 1 | 0 |
|------|-----|-----|----|----|----|----|----|----|----|----|----|----|-----|-----|----|-----|
| Name | D11 | D10 | D9 | D8 | D7 | D6 | D5 | D4 | D3 | D2 | D1 | D0 | OVH | OVL | FE | Res |

- D11..D0 : 12 bit temperature data
- OVH: Overflow flag for Tambient measurement, Ta>Tamax, D[11:0] set to FFFh
- OVL: Underflow flag for Tambient measurement, Ta<Tamin, D[11:0] set to 000h
- FE: Fatal Error in EEPROM.
- Res Not used, always zero.

The measured temperature can be obtained from the register content as follows:

$$T = \frac{Rt}{2^{12} - 1} (Tmax - Tmin) + Tmin$$

Where:

- T measured temperature
- Rt register value (12 bit, 0x000 to 0xFFFF)
- Tmax maximum calibrated temperature
- Tmin minimum calibrated temperature

EEPROM reprogramming

Every MLX90601 module has 8 words of 16bits of EEPROM space free to use for the user. One can freely use this memory space for serialization or storing some other info. Also, in some cases it is necessary to redefine functionality of the MLX90601 infrared module.
The configuration constants are stored in EEPROM non-volatile memory. Note that also the linearization constants are stored in EEPROM, and erasing or over-writing these will irreversibly destroy the modules' proper operation. Reprogramming the EEPROM must be done with care.

Here's how to rewrite a specific EEPROM address.

13. Write 0xB200 to register address 0x10. This unlocks EEPROM control registers. The module now stops updating it's output
14. Write 0x0065 to register address 0x18. Enables charge pump for programming.
15. Erase the address you want to rewrite
16. Write the new data in the EEPROM address
17. Repeat steps 3 and 4 for any further programming
18. You now can cycle the power for restarting the chip in normal operation, with new settings

Make sure never to use the Block Write or Block Erase commands, as they completely erase the EEPROM.

For further details please refer to MLX90313 datasheet.



11.4 Physical outline

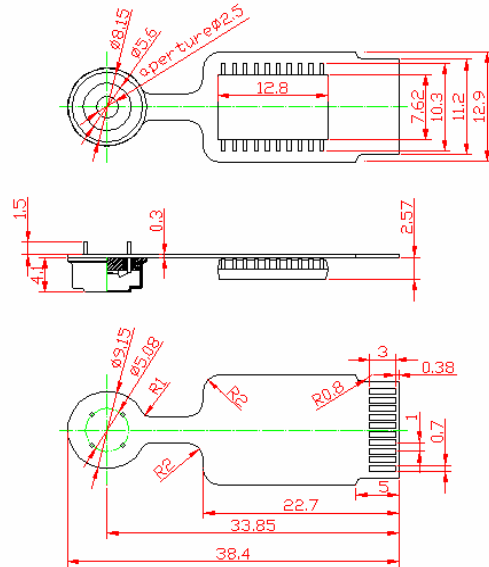

11.5 Pin-out and pin descriptions

| pin-out information | | |
|---------------------|---------|---------------------------------------|
| pin | name | function |
| 1 | VSS | Ground connection |
| 2 | REL1 | Relay output |
| 3 | IROUT | PWM coded output infrared temperature |
| 4 | TEMPOUT | PWM coded output ambient temperature |
| 5 | VREF | Reference voltage output |
| 6 | VDD | Supply voltage |
| 7 | SDIN | SPI data in |
| 8 | SCLK | SPI clock |
| 9 | SDOUT | SPI data out |
| 10 | CSB | SPI chip select |

VSS Supply pin (0V)

REL1 Open drain relay driver output. The typical on-resistance of this driver is <10 Ohms.

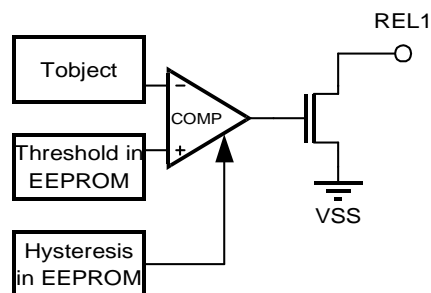

The comparator is a digital comparator, with a resolution of 12 bits. By default the input polarity is inverting. Threshold and hysteresis values are version dependent. These settings can be changed by factory programming on request. Refer to calibration settings for factory preset values.

- IROUT IROUT PWM coded output pin. The duty cycle of the signal on this pin is a linear representation of Tobject, the temperature of the object the IR sensor is pointed at.

- TEMPOUT Tempout PWM coded output pin. The duty cycle of the signal on this pin is a linear representation of Tambient, the temperature of the IR sensor, as measured by the PTC inside MLX90247.

- VREF DAC reference voltage. This voltage must be used if the module is used as a thermostat using the REL1 comparator with external threshold.
- VDD Supply pin

- SDIN SPI data input
- SCLK SPI clock line
- SDOUT SPI data output
- CSB SPI chip select. Active low.

11.6 Electrical specifications

| Parameter | symbol | condition | min | typ | max | unit |
|-------------------------------------|--------|------------------|-------|-------|--------|------|
| Supply Voltage | | | | | | |
| Supply voltage range | VDD | | 4.75 | 5 | 6 | V |
| Power consumption | IDD | Ta=25C | | 5 | 5.6 | mA |
| outputs IROUT/TEMPOUT | | | | | | |
| PWM modulator resolution | | | | 10 | | bits |
| PWM Clock period | Tclk | | 45 | 50 | 55 | µs |
| PWM Total period | T | | 92.16 | 102.4 | 112.64 | ms |
| Leading buffer time | t1 | % of T | | 12.5 | | % |
| Trailing buffer time | t5 | % of T | | 12.5 | | % |
| Duty cycle high | t2 | % of T | 0 | | 50 | % |
| Duty cycle low | t3 | % of T | 0 | | 50 | % |
| Error signal | t4 | % of T | | 25 | | % |
| Rise time* | | 10% to 90% of Vh | 13.3 | | 100 | µs |
| Fall time* | | 90% to 10% of Vh | 13.3 | | 100 | µs |
| Output voltage high | Vh | Ihigh=2mA | 4 | | | V |
| Output voltage low | VI | Ilow=2mA | | | 1 | V |
| Rel1 open drain relay driver | | | | | | |
| output impedance | Ro | | | 10 | | Ohms |
| High voltage protections | | | 32 | | | V |

11.7 Calibration details

| | |
|--|-----------|
| Maximum calibrated object temperature | 120°C |
| Minimum calibrated object temperature | -20°C |
| Object temperature Accuracy | ±2°C |
| Maximum calibrated ambient temperature | -20°C |
| Minimum calibrated ambient temperature | 85°C |
| Ambient temperature Accuracy | ±1°C |
| Response time | 500ms |
| REL1 source | Tobject |
| REL1 polarity (*) | Inverting |
| REL1 threshold | 95°C |
| REL1 hysteresis | 5°C |
| Emissivity | 0.99 |

Note: Comparator polarity:

Inverting: relay switches OFF if temperature is above the threshold.

Non-inverting : relay switches ON if temperature is above the threshold.

11.8 Applications information

Connection of the MLX90601 module into an application is straightforward. The 5V regulated supply should be connected between pin 6 (VDD) and pin 1 (VSS).

The outputs can be measured relative to VSS at pin 3 (IROUT) for Tobject and pin 4 (TEMPOUT) for Tambient, e.g. by means of a voltmeter. In an actual application the module outputs can be directly connected to the A/D inputs of a microcontroller, e.g. as a replacement for a conventional temperature sensor. When large loading capacitances are to be used, a series resistor may be necessary. Refer to electrical specifications.

In many applications, the ambient temperature of the sensor is not needed. In this case, pin 2 can simply be left open.

The REL1 signal can be used as input for a digital I/O or to drive a relay (not shown). In case of a digital input the microcontroller must have internal pull-up resistors or an external pull-up resistor must be added. Here of course the microcontroller connection to the SPI interface is purely optional.

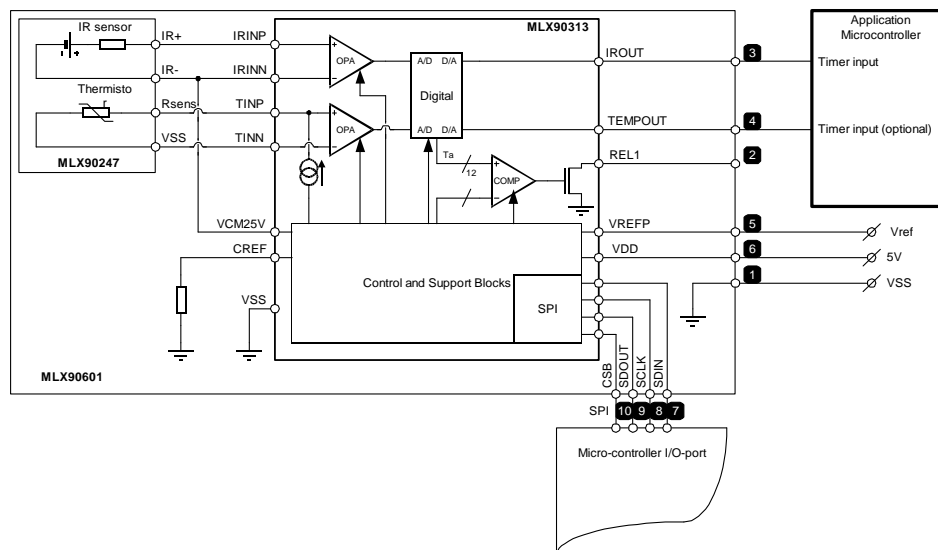

12 ESD Precautions

Electronic semiconductor products are sensitive to Electro Static Discharge (ESD). Always observe Electro Static Discharge control procedures whenever handling semiconductor products.

13 Reliability Information

Melexis devices are classified and qualified regarding suitability for infrared, vapor phase and wave soldering with usual (63/37 SnPb-) solder (melting point at 183degC). The following test methods are applied:

- IPC/JEDEC J-STD-020A (issue April 1999)
Moisture/Reflow Sensitivity Classification For Nonhermetic Solid State Surface Mount Devices
- CECC00802 (issue 1994)
Standard Method For The Specification of Surface Mounting Components (SMDs) of Assessed Quality
- MIL 883 Method 2003 / JEDEC-STD-22 Test Method B102
Solderability

For all soldering technologies deviating from above mentioned standard conditions (regarding peak temperature, temperature gradient, temperature profile etc) additional classification and qualification tests have to be agreed upon with Melexis.

The application of Wave Soldering for SMD's is allowed only after consulting Melexis regarding assurance of adhesive strength between device and board.

For more information on manufacturability/solderability see quality page at our website:
<http://www.melexis.com/>

14 FAQ

Q: What is the accuracy?

A: For the standard offered modules the accuracy is $\pm 2^{\circ}\text{C}$ for the object temperature and $\pm 1^{\circ}\text{C}$ for the ambient temperature.

Q: Does accuracy increase when the temperature range is decreased?

A: No. The main error comes from limited measurement precision during calibration. These imperfections are the same for all modules. High precision calibration can be provided for some custom products. Please contact Melexis customer support.

Q: What is FOV?

A: The FOV or Field Of View is a definition of the area the sensor is 'seeing'. The sensor will detect radiation coming in at an angle, relative to the sensor's central axis, from 0° to 35° . The full viewing angle is thus 70° .

Q: What is the useful temperature range?

A: There are two temperature ranges of interest; the temperature of the object (or target), which you are trying to measure and the temperature of the sensor. The sensor temperature, called T_{ambient} , should be in the calibrated temperature range. See calibration details. Outside this range the ambient temperature compensation will no longer work and calculation of the object's temperature will no longer be correct. The object temperature, called T_{object} , should be between -20°C and 120°C . Outside this range the IROUT output will saturate.



Q: Can the temperature ranges be changed?

A: Yes, MLX90313 is a programmable device. Melexis selected a limited set of standard ranges that will fit the majority of applications in order to limit delivery times. However, if necessary, the ranges can be adapted for any particular application. Depending on the application, the user may do so himself using the EVB board and software. For other applications Melexis may have to do custom calibration. Please contact Melexis customer support.

Q: Can the Field of View (FOV) be made smaller?

A: In theory, yes. In most cases it is sufficient to place a tube over the sensor, narrowing the opening angle. After narrowing the FOV, the module will be out of calibration. For applications that require a small FOV, Melexis can provide custom calibrated devices. Please contact Melexis customer support.

Q: IR radiation is comparable with light. Does my object have to be black?

A: No, the appearance in the visible light spectrum completely differs from the appearance for IR wavelengths. Water and glass for instance, are completely opaque for IR, and thus you can perfectly measure the temperature. Air is transparent for IR and does not influence the measurement. The better name for this property is EMISSIVITY

Q: What is emissivity and how does it affect my measurement?

A: Emissivity is the ratio of the emitted IR energy over the total IR energy that an object has. You can find the value for this property by searching the internet, material data sheets etc. Ice, water, skin, clothes, most non-metallic coatings have an emissivity of 0.90 to 0.99. Emissivity should be close to 1. When measuring objects with low emissivity, reflections of the ambient temperature will come into the thermopile sensor. Therefore there is a measurement error depending on the difference between object and ambient temperature. If the surface of the target has an emissivity lower than 0.7, you can still measure it, but here some tips and tricks are needed. Contact the application engineer for support.

Disclaimer

Devices sold by Melexis are covered by the warranty and patent indemnification provisions appearing in its Term of Sale. Melexis makes no warranty, express, statutory, implied, or by description regarding the information set forth herein or regarding the freedom of the described devices from patent infringement. Melexis reserves the right to change specifications and prices at any time and without notice. Therefore, prior to designing this product into a system, it is necessary to check with Melexis for current information. This product is intended for use in normal commercial applications. Applications requiring extended temperature range, unusual environmental requirements, or high reliability applications, such as military, medical life-support or life-sustaining equipment are specifically not recommended without additional processing by Melexis for each application.

The information furnished by Melexis is believed to be correct and accurate. However, Melexis shall not be liable to recipient or any third party for any damages, including but not limited to personal injury, property damage, loss of profits, loss of use, interrupt of business or indirect, special incidental or consequential damages, of any kind, in connection with or arising out of the furnishing, performance or use of the technical data herein. No obligation or liability to recipient or any third party shall arise or flow out of Melexis' rendering of technical or other services.

© 2002 Melexis NV. All rights reserved.

For the latest version of this document, go to our website at:

www.melexis.com

Or for additional information contact Melexis Direct:

Europe and Japan:

Phone: +32 13 67 04 95
E-mail: sales_europe@melexis.com

All other locations:

Phone: +1 603 223 2362
E-mail: sales_usa@melexis.com

