

- 100-mA Output Sink Current Capability
- Low-Voltage Operation
- MOS- and TTL-Compatible Inputs
- Input Threshold . . . 2.7 V Max
- 7 Drivers (SN75497) or 9 Drivers (SN75498) per Package
- Low-Voltage Saturating Outputs
- Low Standby Power

description

The SN75497 and SN75498 are designed to drive common-cathode LED's in serially addressed multi-digit displays used in conjunction with MOS calculator circuits. The input of each circuit is capable of interfacing with an MOS push-pull output buffer while the output is capable of sinking the output current from a strobed LED display. These drivers are also essentially compatible with TTL inputs. They have a guaranteed threshold of 2.7 volts maximum, making them ideal for two-battery calculators or other low-voltage battery systems. They are designed to be used with active-pull-down MOS devices, but can also be used with open-drain MOS outputs with the addition of pull-down resistors on each input.

The 100-mA output current capability (open collector) and low output saturation voltage makes these devices ideal for other applications such as lamp drivers, relay drivers, line drivers, high-fan-out TTL buffers, etc. The advantages over earlier digit drivers include lower operating voltage, lower output saturation voltage, lower input current, and higher input voltage range.

schematic (each driver)

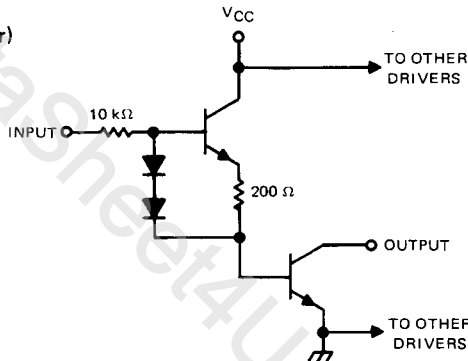

**SN75497 . . . 7 CHANNEL DUAL-IN-LINE PACKAGE
(TOP VIEW)**

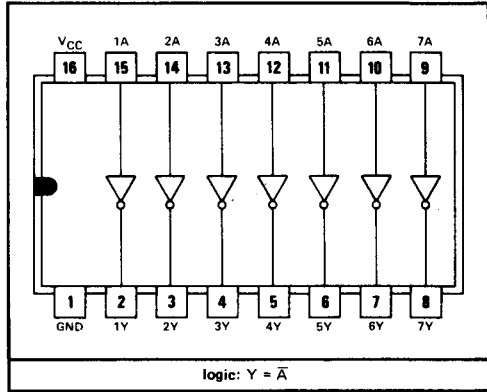

**SN75498 . . . 9 CHANNEL DUAL-IN-LINE PACKAGE
(TOP VIEW)**

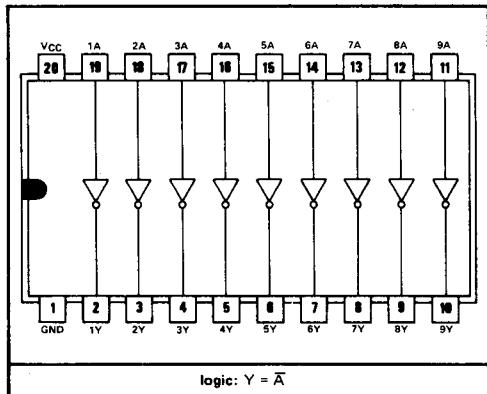

columns
Each of
is which
der, for
put may
a worst
pose a
display
is 4 pF.
were on

er must

i.6 mA.
required
ll the N
rown in
: at zero

IN
RS

s 200 V
de must

i.6 mA.
can also

3
www.DataSheet4U.com

TYPES SN75497, SN75498

MOS-TO-LED 7- OR 9-CHANNEL DRIVERS

absolute maximum ratings over operating free-air temperature range (unless otherwise noted)

Supply voltage, V_{CC} (see Note 1)	
Input voltage	-11 V to V_{CC}
Output voltage	V
Continuous output collector current	125
Ground-terminal current	250
Continuous total dissipation over entire operating range	500
Operating free-air temperature range	0°C to 70°C
Storage temperature range	-65°C to 150°C
Lead temperature 1/16 inch from case for 10 seconds	260

NOTE 1: Voltage values are with respect to network ground terminal.

recommended operating conditions

		MIN	MAX	UNITS
Supply voltage, V_{CC}	2.7	6.6	V
High-level input voltage, V_{IH}	2.7	V_{CC}	V
Low-level input voltage, V_{IL}	-8.5	0	V
Output Current, I_O		100	mA
Operating free-air temperature, T_A	0	70	°C

electrical characteristics over recommended free-air temperature range (unless otherwise noted)

PARAMETER		TEST CONDITIONS			MIN	TYP†	MAX	UNITS
$I_{O(off)}$	Off-state output current	$V_{CC} = 6.6$ V, A at 0 V, Y at 6.6 V			10	100		μ A
$V_{O(on)}$	On-state output voltage	$V_{CC} = 6.6$ V, A at 6.6 V thru 500 Ω , $I_O = 100$ mA			0.24	0.4		V
		$V_{CC} = 2.7$ V, A at 2.7 V thru 500 Ω	$I_O = 50$ mA		0.12	0.25		V
I_{IH}	High-level input current	$V_{CC} = 6.6$ V, A at 6.6 V, $I_O = 100$ mA			0.6	1		mA
		$V_{CC} = 2.7$ V, A at 2.7 V, $I_O = 100$ mA				0.4		mA
I_{IL}	Low-level input current	$V_{CC} = 6.6$ V, A at -8.5 V, $V_O = 6.6$ V			-10	-100		μ A
		$V_{CC} = 2.7$ V, A at -8.5 V, $V_O = 2.7$ V				-100		μ A
I_{CC}	Supply current	One driver on	$V_{CC} = 6.6$ V, One A input at 6.6 V, $I_O = 100$ mA, Other A inputs at 0 V		2.5	5		mA
		All drivers off	$V_{CC} = 6.6$ V, All inputs at 0 V			200		μ A

† All typical values are at $T_A = 25^\circ\text{C}$

TYPES SN75497, SN75498 MOS-TO-LED 7- OR 9-CHANNEL DRIVERS

switching characteristics, $V_{CC} = 5\text{ V}$, $T_A = 25^\circ\text{C}$

PARAMETER		TEST CONDITIONS	MIN	TYP	MAX	UNIT
t_{PLH}	Propagation delay time, low-to-high level output	$C_L = 15\text{ pF}$, $R_L = 47\ \Omega$		250		ns
t_{PHL}	Propagation delay time, high-to-low level output			40		ns

PARAMETER MEASUREMENT INFORMATION

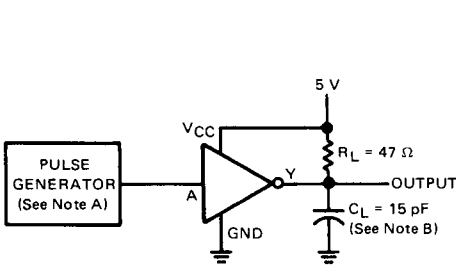

TEST CIRCUITS

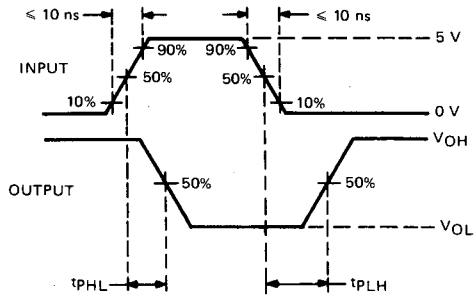

VOLTAGE WAVEFORMS

NOTES: A. The pulse generator has the following characteristics: $Z_{out} = 50\ \Omega$, $PRR = 100\text{ kHz}$, $t_w = 1\ \mu\text{s}$.
B. C_L includes probe and jig capacitance.

FIGURE 1—PROPAGATION DELAY TIMES

TYPICAL CHARACTERISTICS

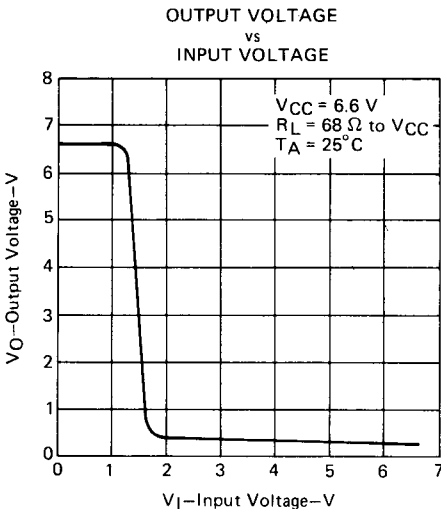

FIGURE 2

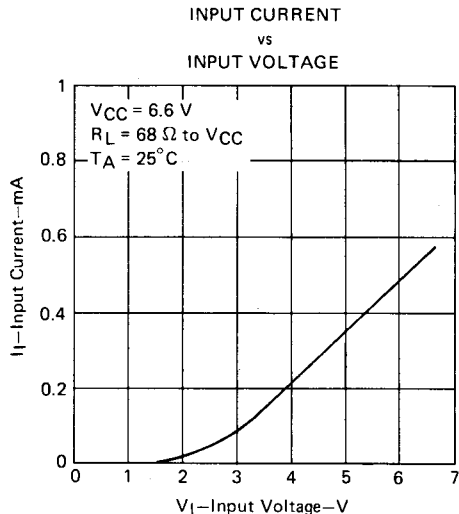

FIGURE 3