



Silicore

TV VIF & SIF & DEFLECTION SYSTEM

D2915

(IC FOR TV LARGE INTEGRATION)

GENERAL DESCRIPTION

The D2915 is a monolithic integrated circuit containing all stages for the VIF, SIF and deflection functions of television receivers.

OUTLINE DRAWING

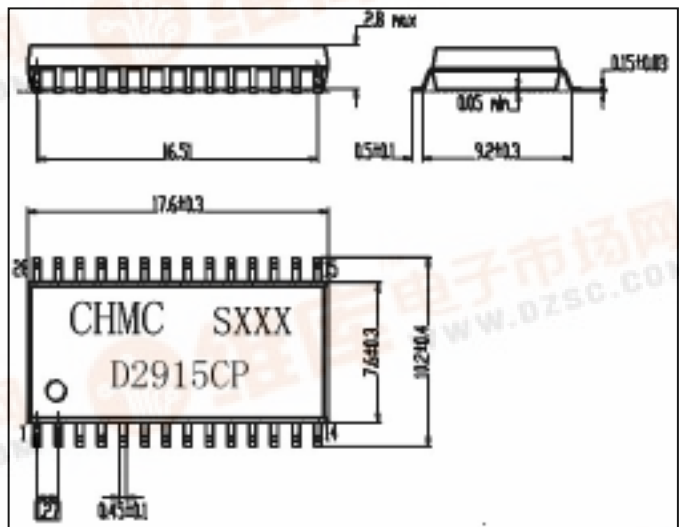

FUNCTIONS

- IF AMP
- Video Amp
- IF AGC
- Tuner AFT
- Sound DET. (FM DET.)
- Vertical trig.
- Vertical drive
- Horizontal drive
- Video DET. (AM DET.)

- Noise canceller
- Forward RF AGC
- SIF Amp
- Sync separation
- Vertical oscillation
- Horizontal oscillation
- Horizontal AFC

FEATURES

- High integrator technology makes it possible the integration of video IF circuit, tuner AFC circuit, sound IF circuit and deflection-jungle circuit on one single chip.
- Supply voltage range : 8~12V (Typ. 10V).
- Operating Temperature: -20°C~+70°C



BLOCKDIAGRAM

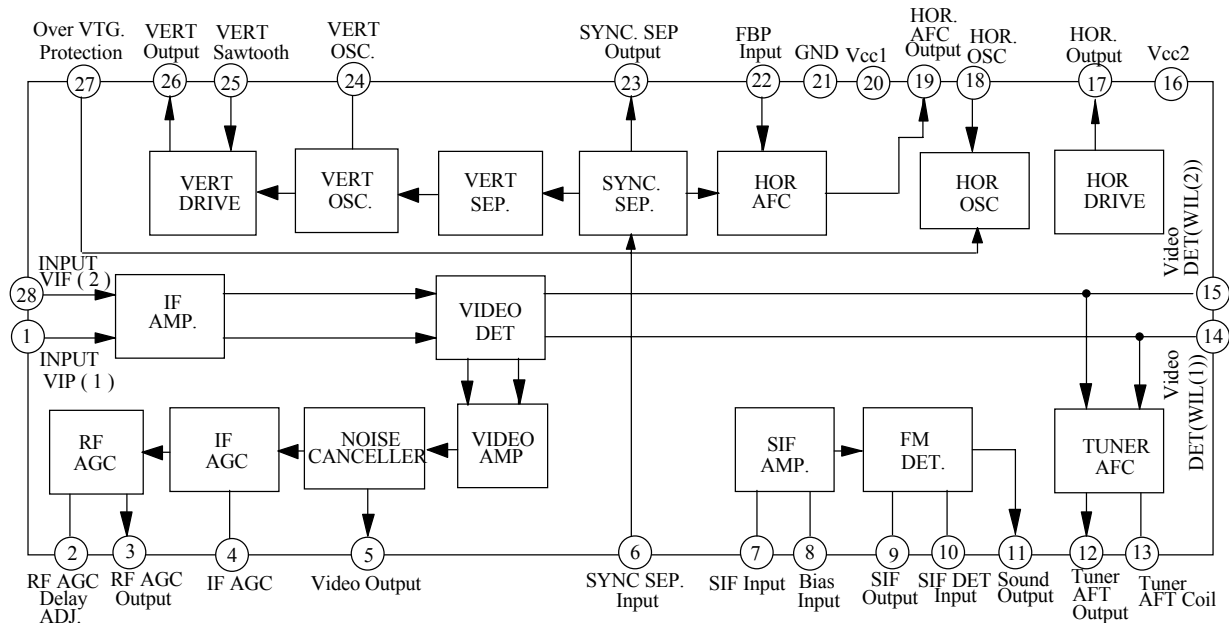

ABSOLUTE MAXIMUM RATINGS(TA=25°C)

Characteristic	Symbol	Value		Unit
Supply Voltage	Vcc(V ₂₀₋₂₁)	12		V
Supply Current	I ₂₀	85		mA
	I ₁₆	15		mA
Circuit Voltage	V _{2,3,4,24-21}	V ₂₀₋₂₁	0	V
	V ₈₋₂₁	5.5	0	
	V ₁₃₋₂₁	4.2	0	
	V ₁₇₋₂₁	V ₁₆₋₂₁	0	
Circuit Current	I _{5,6,11,23,26}	+0.3	-10	mA(peak)
	I ₁₉	+0.6	-0.6	
	I ₂₅	+10	0	
	I ₁₇	+10	-4	
Power Dissipation (Ta=70°C)	P _D	1100		mW
Operating Temperature	T _{OPR}	-20~+70		°C
Storage Temperature	T _{STG}	-55~+150		°C



ELECTRICAL CHARACTERISTICS (V_{CC1}=10V, V_{CC}=9.5V, T_a=25°C)

Video Section

Characteristic	Symbol	Test Condition	Min	Typ	Max	Unit
Video Det. Output	V _O	m=87.5%	1.8	2.1	2.4	V _{p-p}
Input Sensitivity	V _S	V _O =-3dB		50	55	dBμ
Maximum Input	V _{MAX}	V _O >+0dB	105	110		dBμ
SN Rating	S/N	V _i =80dBμ	51	56		dBμ
Differential Gain	A _D	m=87.5%		4	8	%
Differential Phase	SPD	m=87.5%		3	6	deg
Video Freq. Characteristic	f _c	V _O =-3dB	4.5	6.0	8.0	MHz
Sync. Peak Voltage	V _P		1.9	2.3	2.7	V
Noise Inverter Output Level	V _{NT}		1.0	1.4	1.8	V
Noise Inverter Capture Level	V _{NI}		3.0	4.0	5.0	V
Sound IF Output	V _{SIF}	P/S=20dB	100	104	107	dBμ
Input Resistor (pin 1)	R _{INI}	f=45.75MHz	0.8	1.0	1.2	kΩ
Input Capacitor(pin 1)	C _{ZNI}	f=45.75MHz	3.0	3.4	3.8	pF
Output Resistor(pin 5)	R _{O5}	f=500kHz	30	50	150	Ω
RF AGC Max. Voltage	G _{RFAGC}	f=10kHz, V ₄ =5mV	36	42	48	dB
RF AGC Max. Voltage	V _{3(MAX)}		8.2	8.8	9.4	V
RF AGC Min. Voltage	V _{3(MIN)}		3.6	4.2	4.8	V
AFC Center Voltage	V ₂		4.0	5.4	6.0	V
AFC SW Operating Voltage	V _{AFTSW}	R _S =10k	0.5	2.6	3.0	V
AFC Max Output Voltage	V _{I2(Max.)}		8.5	9.6	10.0	V
AFC Min Output Voltage	V _{I2(Min.)}		0	0.7	1.2	V
Selection Sensitivity	μ	R _L =68k /82k	30	50	90	mV/kHz

Sound Section

Characteristic	Symbol	Test Condition	Min	Typ	Max	Unit
Sound Det. Output	V _O	f _o =4.5MHz, f _m =400Hz f=±25kHz, V _i =100mVrms	200	300	400	mVrms
Input Limit Voltage	V _{I(LIM)}	f=4.5MHz, f _m =400Hz f=±25kHz		280	450	μVrms
Total Harmonic Distortion	THD	f _o =4.5MHz, f _m =400Hz		0.6	1.0	%
AM Rejection Ratio	AMR	f=±25kHz, V _i =100mVrms	43	55		dB
Input Impedance	R ₁₇	f=4.5MHz	6	20	100	k
	C ₁₇		1.3	4.3	7.3	pF



Sound Section

continue

Characteristic	Symbol	Test Condition	Min	Typ	Max	Unit
Detector Input Impedance	R _{D9}	f=4.5MHz	2.0	3.0	4.0	k
	C _{D9}		2.1	5.1	8.1	pF
	R _{D10}		50	200		k
	C _{D10}		2.9	3.4	3.9	pF

Deflection Section

Characteristic	Symbol	Test Condition	Min	Typ	Max	Unit
Sync Sep. Hori. Pulse Width (1)	T _{sync1}	Video Input 2.5Vp-p, APL=50%, V _{cc1} =10V	4.8	5.1	5.4	μS
Sync Sep. Hori. Pulse Width (2)	T _{sync2}	Video Input 1.0Vp-p, APL=50%, V _{cc1} =10V	4.9	5.2	5.5	μS
Hori. AFC Hori. Pulse Width (1)	T _{sync3}	Video Input 2.5Vp-p, APL=50% V _{cc1} =10V	4.8	5.1	5.4	μS
Hori. AFC Hori. Pulse Width (2)	T _{sync4}	Video Input 1.0Vp-p, APL=50%, V _{cc1} =10V	4.9	5.2	5.5	μS
Vert Osc, Start Supply Voltage	V _{fvo}	f _{vo} =40~60Hz Output=0.7Vp-p		4.9	6	V
Vert. Free Running Frequency	f _{vo}	R _{osc(v)} =30 k V _{cc1} =10V	57	60	63	Hz
Vert. OSC. Pulse Width	T _{vo}	R _{osc(v)} =30 k V _{cc1} =10V	470	650	830	μS
Vert. full in Range	f _{vo/Vcc}	V _{cc1} =12V, 8V f _{vo/Vcc} =f _{vo} (12V)-f _{vo} (8V)	0	1.0	1.3	Hz
Vert. full in Range	f _{pv}	Composite Signal Input 2Vp-p V _{cc1} =10V	39	43	47	Hz
Hori. OSC. Start Supply Voltage	V _{hHO.S}	f _{hO} =10~20kHz Output=1Vp-p Pin16 Voltage		3.7	5	V
Hori. OSC. Freq.	f _{hO}	R _{osc(H)} =21K+B=20V	15.0	15.75	16.25	kHz
Hori. OSC. Pulse Width	T _{hO}	R _{osc(H)} =21 K+B=20V	21	24	27	μS
Hori. OSC. Freq. Voltage Dependent	f _{hO/Vcc}	V _{cc2} =10V,8V f _{hO/Vcc} = f _{hO} (10V)-f _{hO} (8V)	0	50	100	Hz
Hori. OSC. Control sensitivity	β	I ₁ ± 100μA Input Variable OSC. Freq. Variable	73	81	89	Hz/μA
Phase Det. Sensitivity	μ _p	TV Input 2Vp-p, R(U)=31.4k , μ=V19*10	13.5	16.5	19.5	μA/μS
X-Ray Protector Operating Voltage	V27-21		0.81	0.87	0.93	V
X-Ray Protector Input Resistor	R27		16	19	22.5	k



TYPICAL APPLICATION CIRCUIT (12" or 14" B/W TV)

