

Preliminary

MITSUBISHI[Standard Linear IC]

M62580P

High speed High voltage OP. Amp.

Notice: This is not a final specification.
Some parametric limits are subject to change.

DESCRIPTION

M62580P is a semiconductor integrated circuit designed for capacitive load drive that operates at single power supply. M62580P features high voltage operation with fixed voltage gain (18.00V/V) and built-in pre-amplifier with high slew rate. For output, AB class Amp. can be structured by connecting 2 emitter outputs, also featuring distinctive characteristics for high current load.

FEATURES

- *High voltage ----- $V_{CC}=42V$ (typ.)
- *High slew rate----- $35V/\mu s$ (typ.)
- *High current(Io: peak current)----- $\pm 120mA$ (min.)
- *Gain----- $18.00V/V$ (typ.)
- *Output voltage range----- $V_{OL}=0.8V$ (typ.), $V_{CC}-V_{OH}=0.8V$ (typ.)

APPLICATION

*For capacitive load drive, etc.

PIN CONFIGURATION(TOP VIEW)

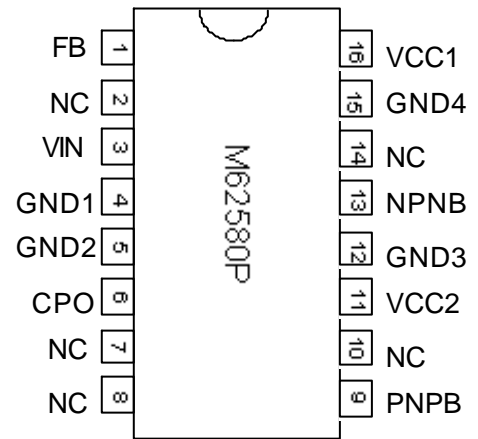

Outline 16P4

BLOCK DIAGRAM

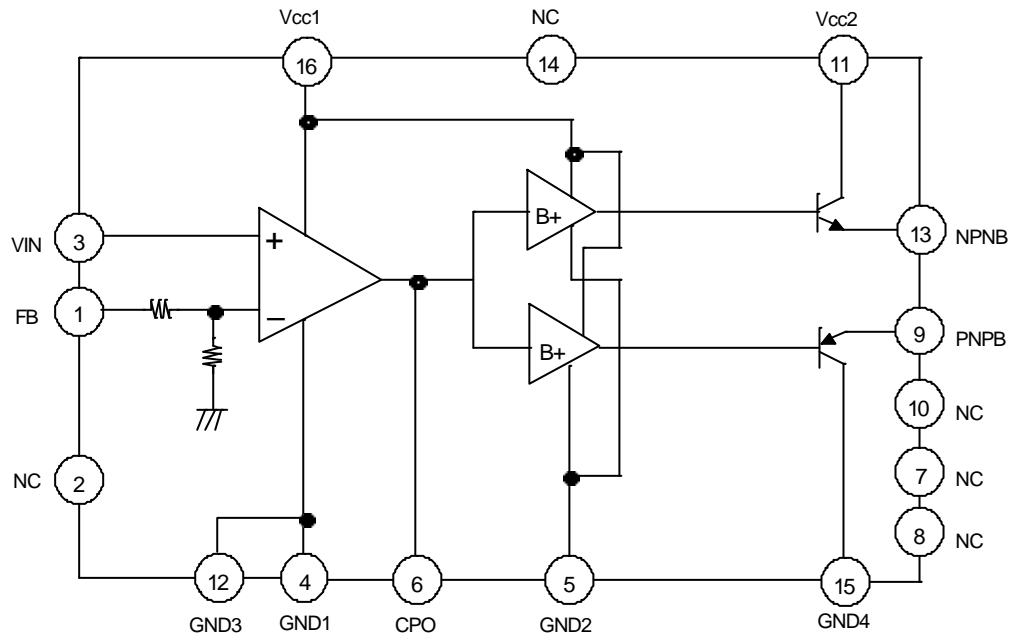

Preliminary

MITSUBISHI[Standard Linear IC]

M62580P

High speed High voltage OP. Amp.

ABSOLUTE MAXIMUM RATINGS (Ta=25°C unless otherwise noted.)

Symbol	Parameter	Conditions	Ratings	Unit
V _{CC}	Supply voltage		50	V
I _O	Output current	peak current	±150	mA
V _{IN}	Input voltage		0.0~3.0	V
P _d	Power dissipation	Ta=25°C	2.5	W
K _q	Thermal derating	Ta>25°C	20	mW/°C
T _{opr}	Operating temperature		-20~75	°C
T _{stg}	Storage temperature		-40~150	°C

ELECTRICAL CHARACTERISTICS (Ta=25°C.V_{CC1}=V_{CC2}=42V unless otherwise noted.)

Symbol	Parameter	Test conditions	Limits			Unit	Remarks
			Min.	Typ.	Max.		
I _{CC}	Circuit current	V _{IN} =0.1V	15.14	22.00	28.60	mA	
V _{OFF}	Offset voltage	V _{IN} =80mV	1.15	1.44	1.72	V	
I _{IB}	Input bias current	V _{IN} =1V		-0.5		μA	
A _v	Voltage gain	V _{IN} =80mV~2.08V	16.20	18.00	19.80	V/V	
V _{OL}	Output low voltage	PNPB/NPNB output		0.8	1.1	V	
V _{OH}	Output high voltage	V _{CC} -PNPB/NPNB output		0.8	1.1	V	
SR	Slew rate	PNPB/NPNB output voltage change	25	35		V/μs	
I _{source}	Output source current	peak current			-120	mA	
I _{sink}	Output sink current	peak current	120			mA	

RECOMMENDED OPERATING CONDITIONS

Symbol	Parameter	Test conditions	Limits			Unit	Remarks
			Min.	Typ.	Max.		
V _{CC}	Supply voltage		40	42	45	V	
V _{INL}	Input low voltage			TBD		mV	
V _{IN}	Input amplitude			2.0		V _{pp}	

Preliminary

MITSUBISHI[Standard Linear IC]

M62580P

High speed High voltage OP. Amp.

Measurement circuit

1. Circuit current (I_{cc})

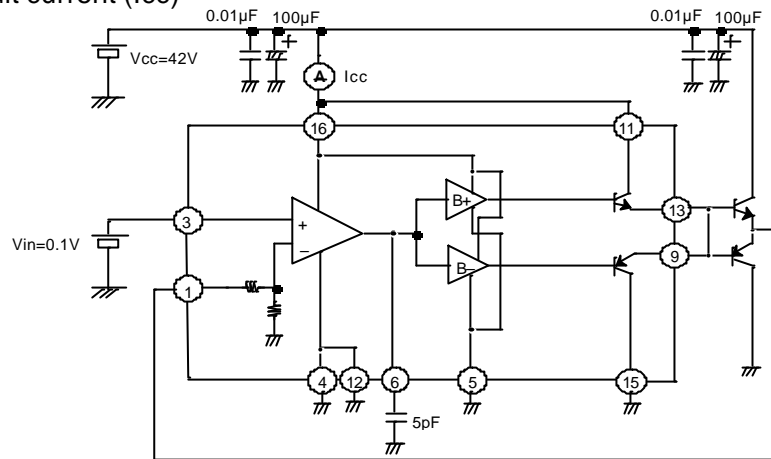

Measure sink current to 11pin and 16pin

2. Offset voltage (V_{off})

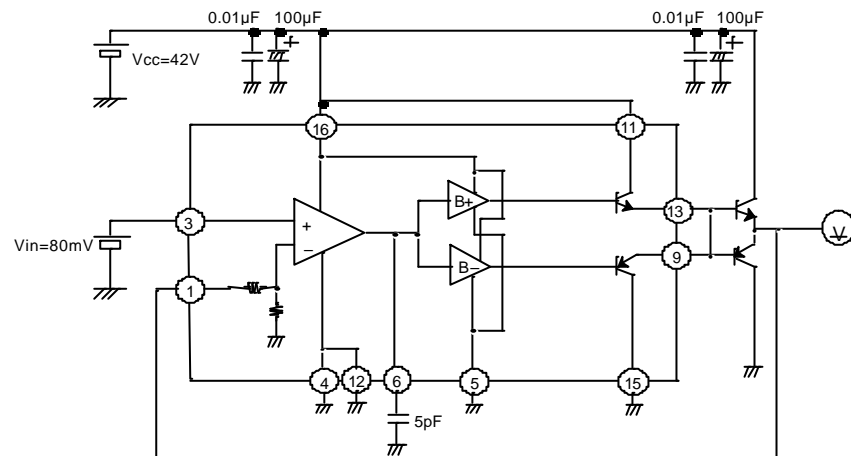

Measure power Tr. output voltage when 80mV DC voltage is applied to 3pin.

M62580P

High speed High voltage OP. Amp.

Measurement circuit (continued)

3. Input bias current (IIB)

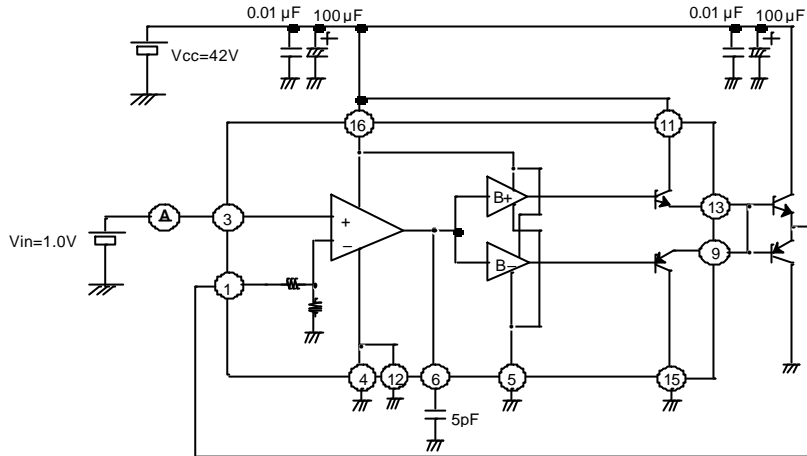

Measure source current from 3pin when 1.0V DC voltage is applied to 3pin.

4. Voltage gain(V/V)

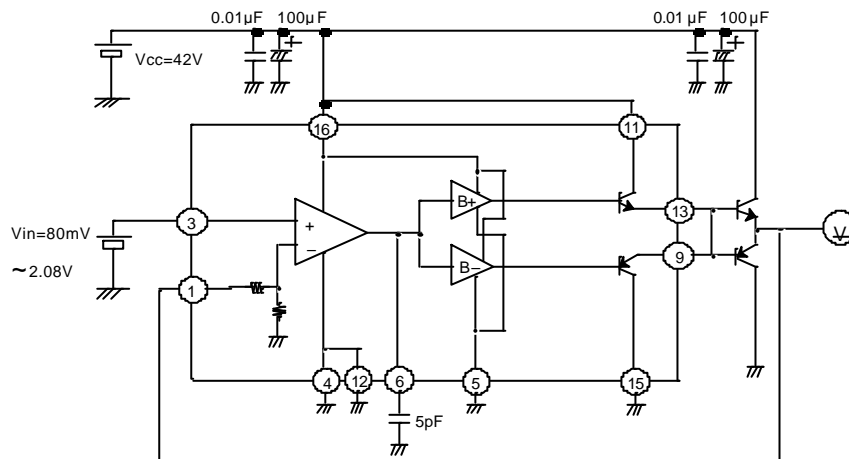

Measure gain for 3pin input voltage

Preliminary

MITSUBISHI[Standard Linear IC]

M62580P

High speed High voltage OP. Amp.

Measurement circuit (continued)

5. Output low voltage, Output high voltage (VOL, VOH)

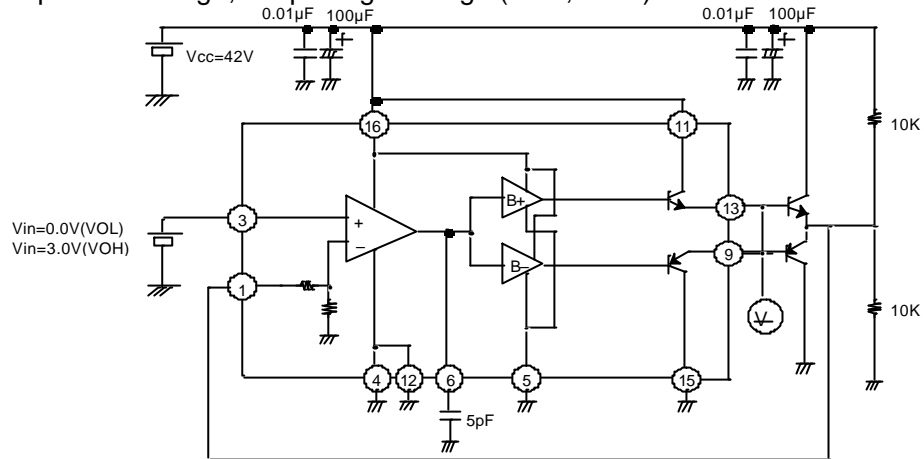

VOL: Measure 9pin, 13pin output voltage when 0.0V DC voltage is applied to 3pin.

VOH: Measure the differential voltage between Vcc and 9pin, 13pin output voltage when 3.0V DC voltage is applied to 3pin.

6. Slew rate (SR)

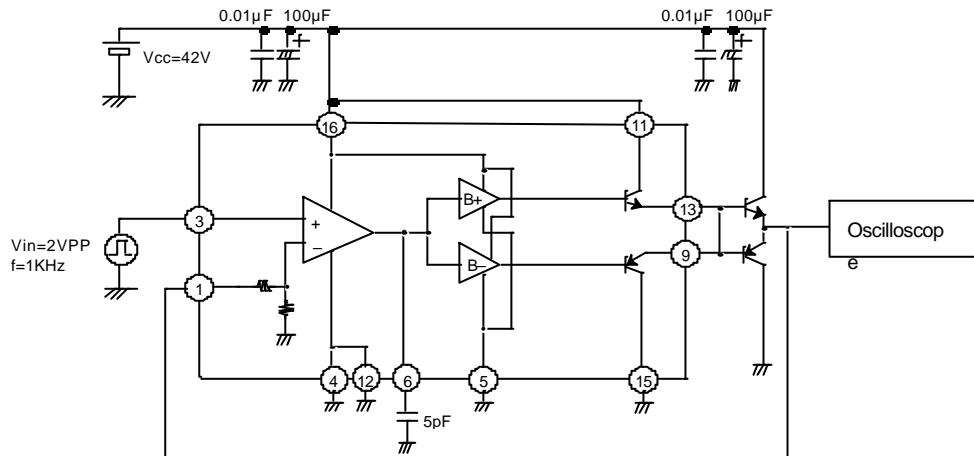

Measure rise/fall for the pulse output of power Tr. by inputting pulse signal to 3pin.

M62580P

High speed High voltage OP. Amp.

Measurement circuit (continued)

7. Output source current, Output sink current (I_{source}, I_{sink})

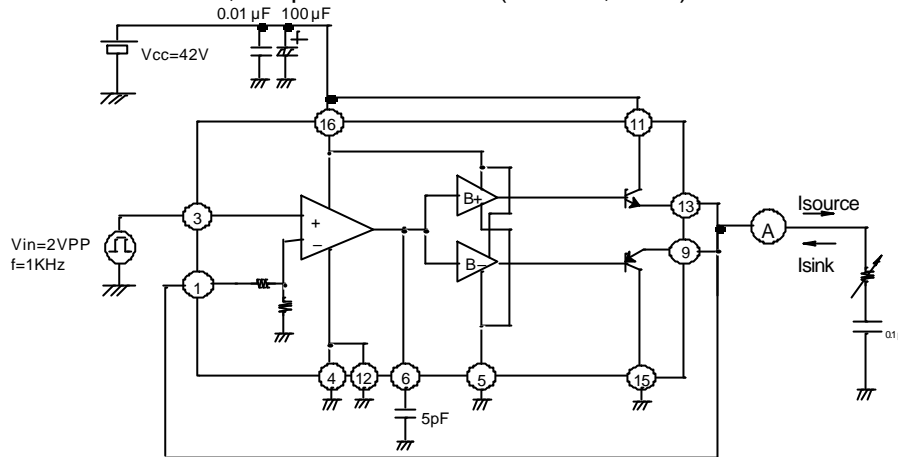

Connect resistor and capacitor to 9pin, 13pin output and input pulse signal to 3pin.
Measure peak current to load by current probe

Application circuit

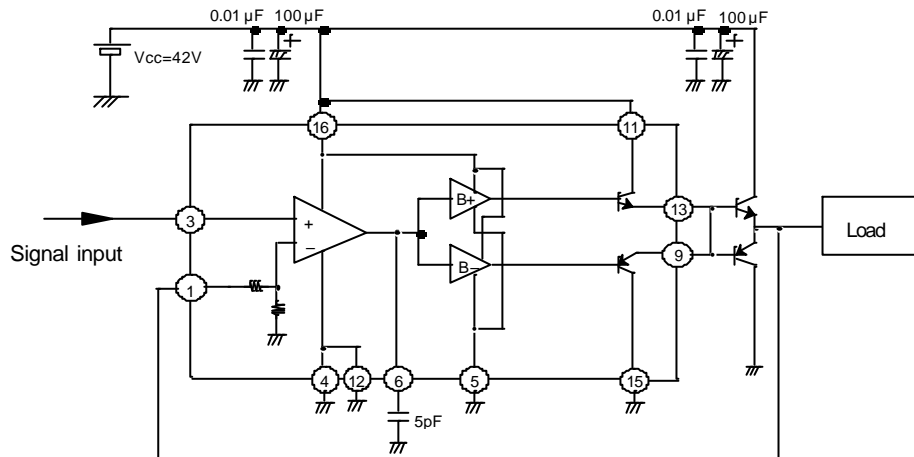

Note:

- (1) Connect ceramic capacitor(approx. 0.01μF) and electrolytic capacitor(10μF or more) for decoupling between 11pin, 16pin supply voltage terminal and 4pin, 5pin, 15pin GND terminal by the shortest possible wire.
- (2) Utmost care should be taken to heat dissipation by making the GND pattern layout as broad as possible because operation is made under high speed and high voltage.
- (3) Connect phase compensating capacitor for 6pin. 5pF is recommendable.