

NEC ELECTRONICS INC

30E D ■ 6427525 0025400 7 ■

NEC

NEC Electronics Inc.

μPD75516/P516
4-Bit, Single-Chip
Microcomputer With Extensive
I/O and A/D Converter

T-49-19-44

T-49-19-59

Description

The μPD75516 and μPD75P516 are high-performance, single-chip CMOS microcomputers that contain a CPU, ROM, RAM, I/O ports, interval timer, timer/event counter, watch timer, timer/pulse generator, an A/D converter, vectored interrupts, and a serial interface.

The Instruction set allows the user to manipulate RAM data and I/O ports in 1-, 4-, and 8-bit units. The μPD75516 contains a large amount of 8-bit instructions, which enables this chip to be used in applications where previous 4-bit microcomputers could not be used.

Features

- Program memory (ROM): 16256 bytes
- Data memory (RAM): 512 x 4 bits
- Instruction execution times at 4.19 MHz
 - High-speed cycle: 0.95 μs
 - Lower-voltage cycles: 1.91 μs and 15.3 μs
- 136 instructions
 - Bit-manipulation instructions
 - 4-bit and 8-bit transfer, arithmetic, logical, comparison, and increment/decrement instructions
 - 1-byte relative branch instructions
 - GETI instruction that converts one 2-byte instruction or two 1-byte instructions into one 1-byte instruction
- Four register banks with eight 4-bit registers/bank
- Accumulators
 - 1-bit accumulator (CY)
 - 4-bit accumulator (A)
 - 8-bit accumulator (XA)
- 64 port lines
 - 48 I/O lines
 - 16 input-only lines
 - 28 outputs can drive a LED directly
 - 24 mask option pull-up/pull-down resistors
- Eight input 8-bit A/D converter
- Timers
 - One 8-bit basic interval timer
 - One 8-bit timer/event counters
 - One 14-bit timer/pulse generator with PWM
 - One 14-bit watch timer
- 2-channel, 8-bit serial interface
 - SBI mode
 - 2- or 3-wire mode:

Data transfer can be MSB or LSB first

- Full-duplex mode
- Receive-only mode
- 16-bit sequential buffer
- Vectored interrupts
 - Two levels of nesting
 - Three external interrupts
 - Four internal interrupts
 - Nine external and one internal sources which generate interrupt requests
- Operates with oscillator or ceramic resonator
- CMOS technology at 5 V and 4.19 MHz
 - Normal operation: 3.0 mA typical
 - HALT mode: 0.6 mA typical
 - STOP mode: 0.5 μA typical
- 2.7 to 6 V operation
- Programmable versions: OTP and EPROM



Applications

- Home and business telephones
- Data terminals
- Industrial control
- Medical instruments
- Meters

75X Family

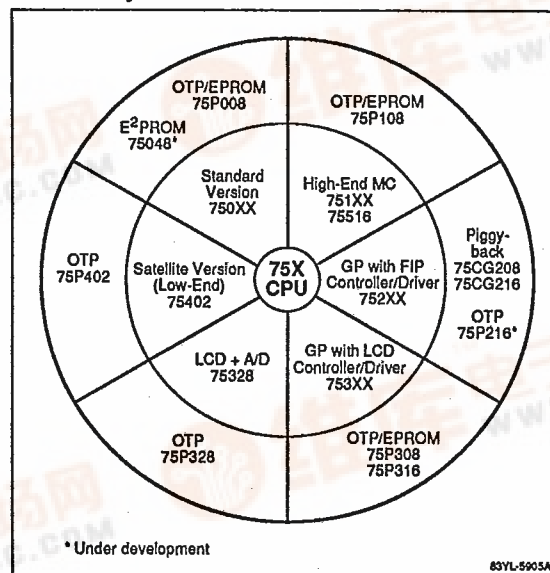

μPD75516/P516

T-49-19-44

T-49-19-59

Ordering Information

Part Number	Package	ROM Type
μPD75516GF-xxx-3B9	80-pin plastic miniflat	Mask ROM
μPD75P516GF	80-pin plastic miniflat	OTP ROM
μPD75P516K	80-pin LCC	OTP ROM

Block Diagram

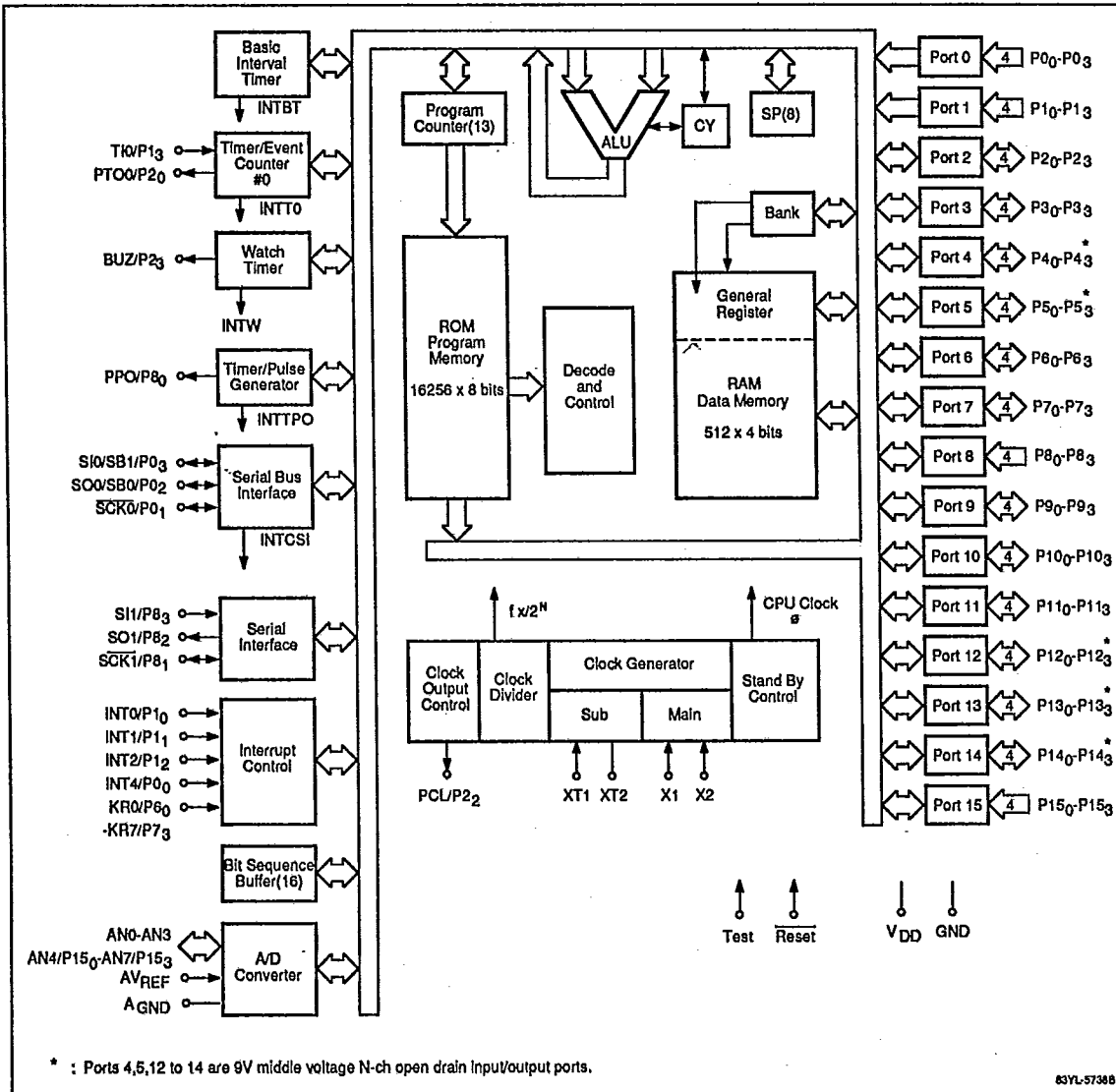

* : Ports 4,5,12 to 14 are 9V middle voltage N-ch open drain Input/output ports.

83YL-57388