



MOTOROLA

Dual Timing Circuit

The MC3456 dual timing circuit is a highly stable controller capable of producing accurate time delays, or oscillation. Additional terminals are provided for triggering or resetting if desired. In the time delay mode of operation, the time is precisely controlled by one external resistor and capacitor per timer. For astable operation as an oscillator, the free running frequency and the duty cycle are both accurately controlled with two external resistors and one capacitor per timer. The circuit may be triggered and reset on falling waveforms, and the output structure can source or sink up to 200 mA or drive M TTL circuits.

- Direct Replacement for NE555/SE555 Timers
- Timing from Microseconds through Hours
- Operates in Both Astable and Monostable Modes
- Adjustable Duty Cycle
- High Current Output can Source or Sink 200 mA
- Output can Drive M TTL
- Temperature Stability of 0.005% per °C
- Normally "On" or Normally "Off" Output
- Dual Version of the Popular MC1455 Timer

MC3456

DUAL TIMING CIRCUIT

SEMICONDUCTOR TECHNICAL DATA

P SUFFIX
PLASTIC PACKAGE
CASE 646

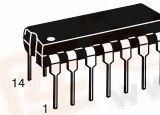

D SUFFIX
PLASTIC PACKAGE
CASE 751
(SO-14)

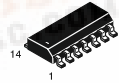

PIN CONNECTIONS

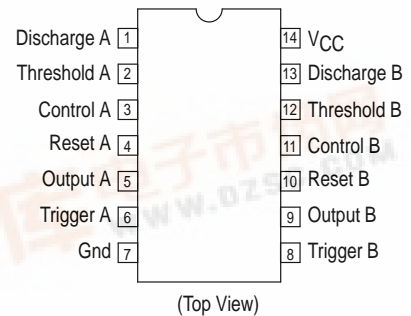

ORDERING INFORMATION

Device	Operating Temperature Range	Package
MC3456P	0° to +70°C	Plastic DIP
NE555D		SO-14

Figure 1. 22 Second Solid State Time Delay Relay Circuit

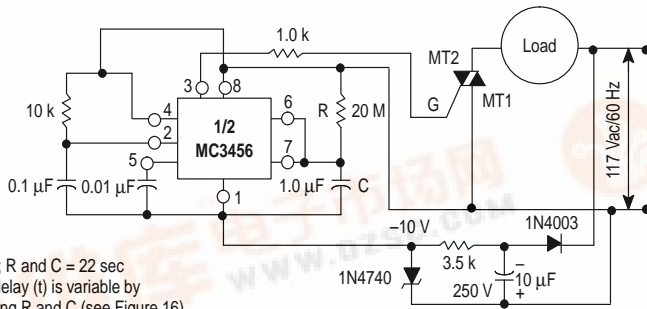
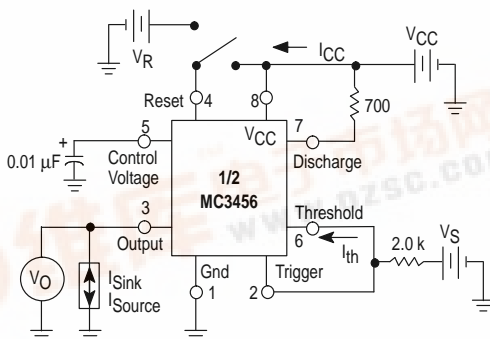

Figure 3. General Test Circuit



Test circuit for measuring DC parameters (to set output and measure parameters):

- When $V_S \geq 2/3 V_{CC}$, V_O is low.
- When $V_S \leq 1/3 V_{CC}$, V_O is high.
- When V_O is low, Pin 7 sinks current. To test for Reset, set V_O high, apply Reset voltage, and test for current flowing into Pin 7. When Reset is not in use, it should be tied to V_{CC} .

Figure 2. Block Diagram (1/2 Shown)

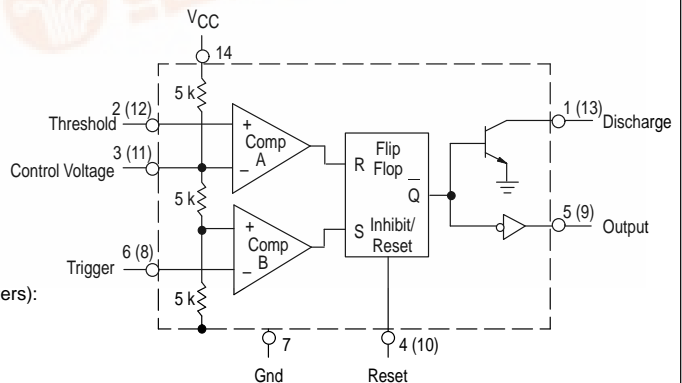

MC3456

MAXIMUM RATINGS (T_A = +25°C, unless otherwise noted.)

Rating	Symbol	Value	Unit
Power Supply Voltage	V _{CC}	+18	Vdc
Discharge Current	I _{dis}	200	mA
Power Dissipation (Package Limitation)	P _D		
P Suffix, Plastic Package, Case 646		625	mW
Derate above T _A = +25°C		5.0	mW/°C
D Suffix, Plastic Package, Case 751		1.0	W
Derate above T _A = +25°C		8.0	mW/°C
Operating Ambient Temperature Range	T _A	0 to +70	°C
Storage Temperature Range	T _{stg}	-65 to +150	°C

ELECTRICAL CHARACTERISTICS (T_A = +25°C, V_{CC} = +15 V, unless otherwise noted.)

Characteristics	Symbol	Min	Typ	Max	Unit
Supply Voltage	V _{CC}	4.5	–	16	V
Supply Current	I _{CC}				mA
V _{CC} = 5.0 V, R _L = ∞		–	6.0	12	
V _{CC} = 15 V, R _L = ∞ Low State, (Note 1)		–	20	30	
Timing Error (Note 2)					
Monostable Mode (R _A = 2.0 kΩ; C = 0.1 μF)					
Initial Accuracy		–	0.75	–	%
Drift with Temperature		–	50	–	PPM/°C
Drift with Supply Voltage		–	0.1	–	%/V
Astable Mode (R _A = R _B = 2.0 kΩ to 100 kΩ; C = 0.01 μF)					
Initial Accuracy		–	2.25	–	%
Drift with Temperature		–	150	–	PPM/°C
Drift with Supply Voltage		–	0.3	–	%/V
Threshold Voltage	V _{th}	–	2/3	–	xV _{CC}
Trigger Voltage	V _T				V
V _{CC} = 15 V		–	5.0	–	
V _{CC} = 5.0 V		–	1.67	–	
Trigger Current	I _T	–	0.5	–	μA
Reset Voltage	V _R	0.4	0.7	1.0	V
Reset Current	I _R	–	0.1	–	mA
Threshold Current (Note 3)	I _{th}	–	0.03	0.1	μA
Control Voltage Level	V _{CL}				V
V _{CC} = 15 V		9.0	10	11	
V _{CC} = 5.0 V		2.6	3.33	4.0	
Output Voltage Low	V _{OL}				V
(V _{CC} = 15 V)					
I _{Sink} = 10 mA		–	0.1	0.25	
I _{Sink} = 50 mA		–	0.4	0.75	
I _{Sink} = 100 mA		–	2.0	2.75	
I _{Sink} = 200 mA		–	2.5	–	
(V _{CC} = 5.0 V)					
I _{Sink} = 5.0 mA		–	0.25	0.35	
Output Voltage High	V _{OH}				V
(I _{Source} = 200 mA)					
V _{CC} = 15 V		–	12.5	–	
(I _{Source} = 100 mA)					
V _{CC} = 15 V		12.75	13.3	–	
V _{CC} = 5.0 V		2.75	3.3	–	
Toggle Rate R _A = 3.3 kΩ, R _B = 6.8 kΩ, C = 0.003 μF (Figure 17, 19)	–	–	100	–	kHz
Discharge Leakage Current	I _{dis}	–	20	100	nA
Rise Time of Output	t _{OLH}	–	100	–	ns
Fall Time of Output	t _{OHL}	–	100	–	ns
Matching Characteristics Between Sections					
Monostable Mode					
Initial Timing Accuracy		–	1.0	2.0	%
Timing Drift with Temperature		–	±10	–	ppm/°C
Drift with Supply Voltage		–	0.2	0.5	%/V

- NOTES:** 1. Supply current is typically 1.0 mA less for each output which is high.
 2. Tested at V_{CC} = 5.0 V and V_{CC} = 15 V.
 3. This will determine the maximum value of R_A + R_B for 15 V operation. The maximum total R = 20 mΩ.



MC3456

Figure 4. Trigger Pulse Width

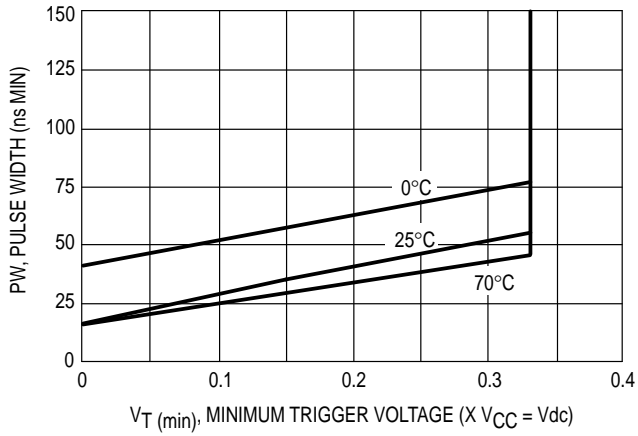

Figure 5. Supply Current

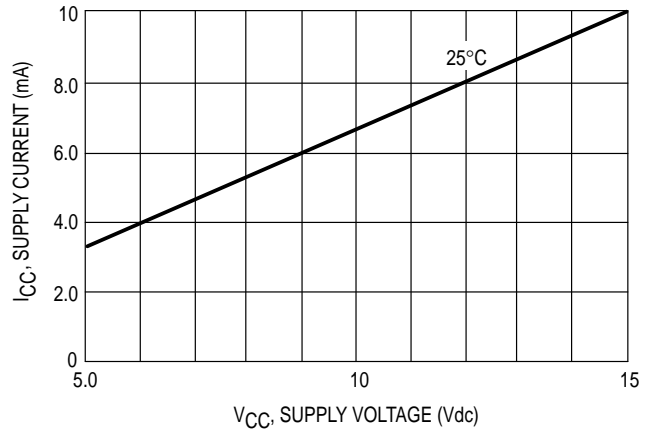

Figure 6. High Output Voltage

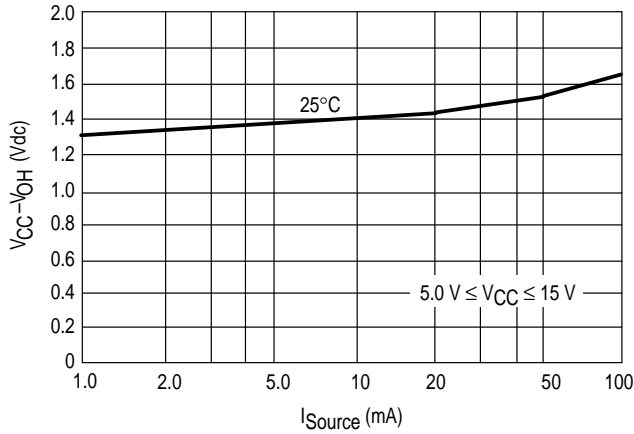

Figure 7. Low Output Voltage
(@ $V_{CC} = 5.0$ Vdc)

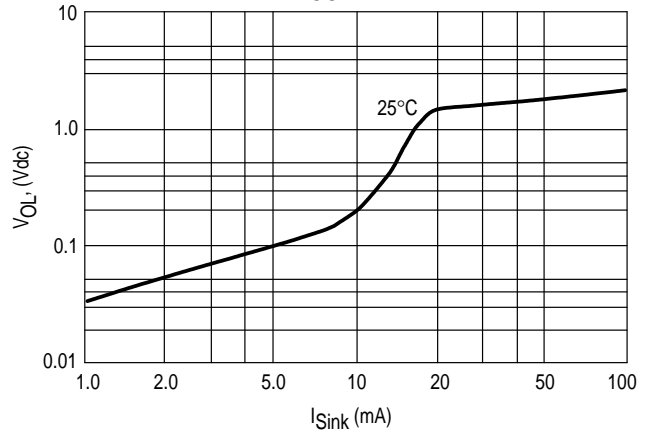

Figure 8. Low Output Voltage
(@ $V_{CC} = 10$ Vdc)

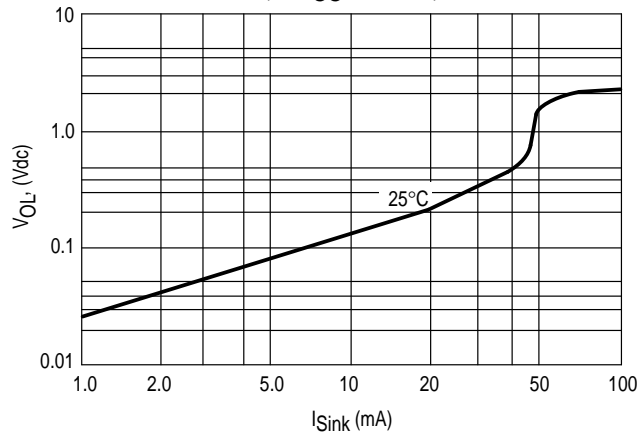
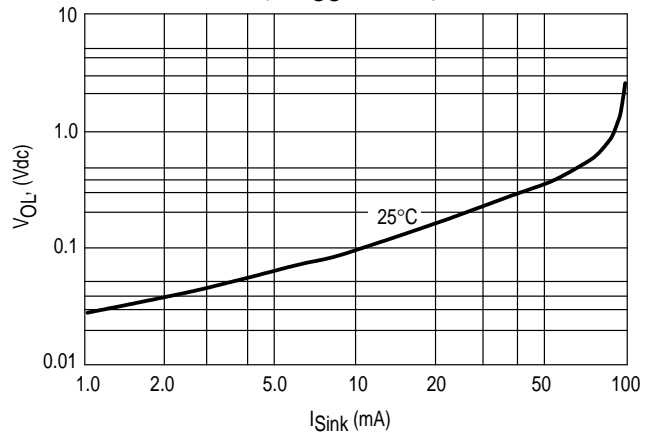

Figure 9. Low Output Voltage
(@ $V_{CC} = 15$ Vdc)



MC3456

Figure 10. Delay Time versus Supply Voltage

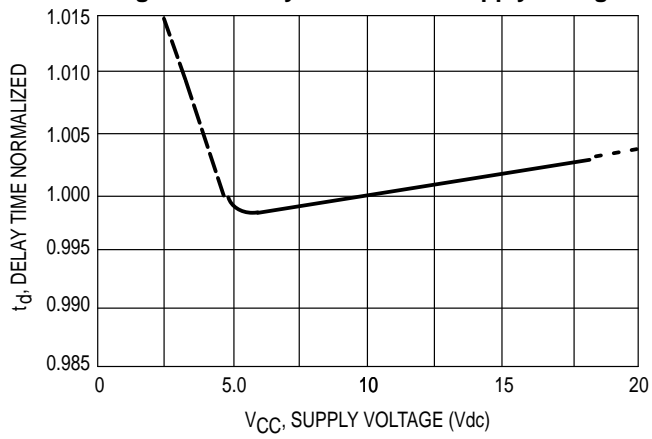

Figure 11. Delay Time versus Temperature

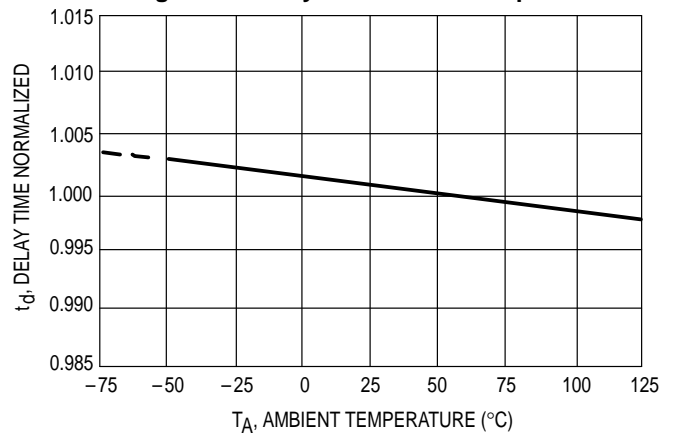
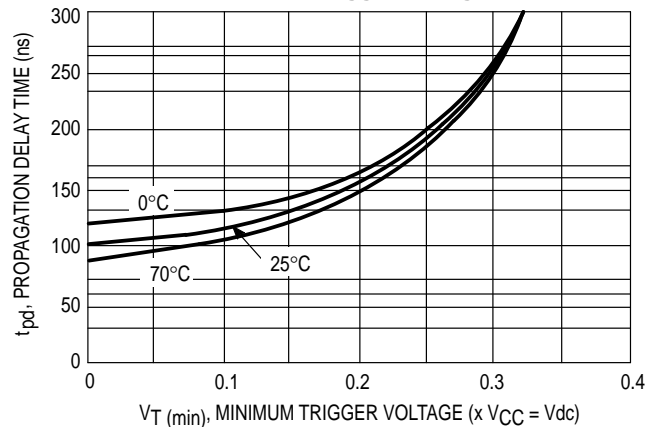
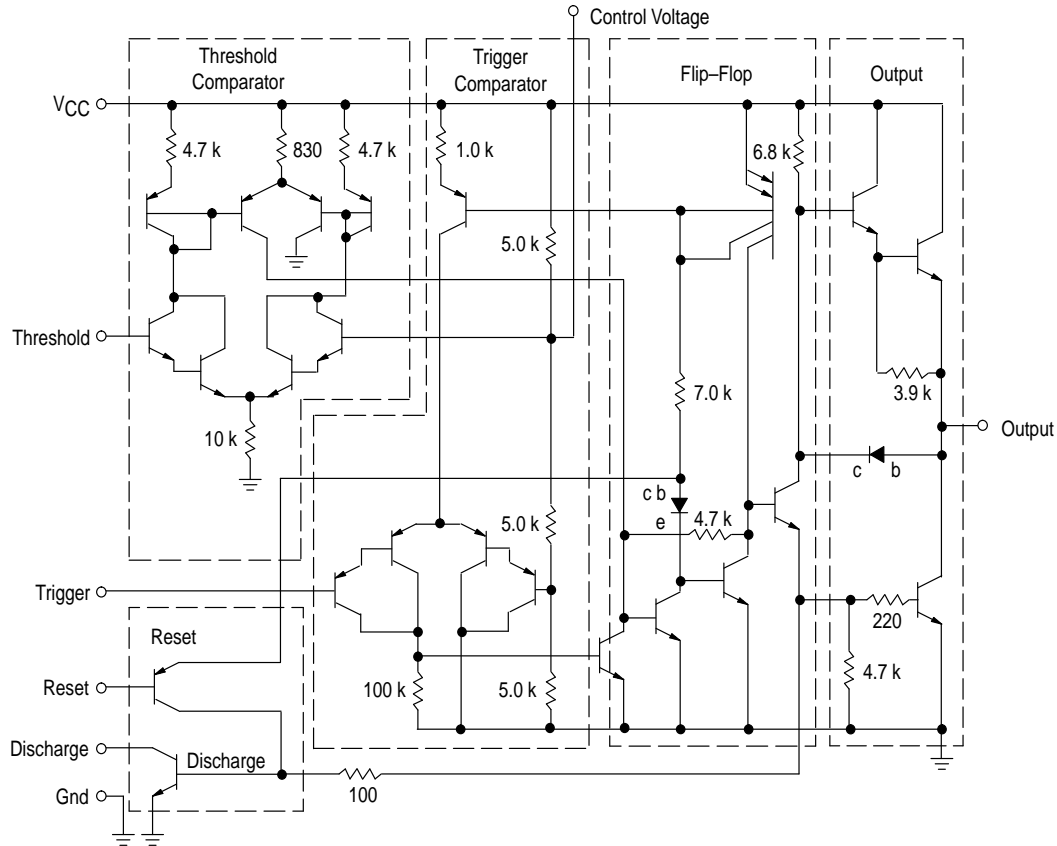

Figure 12. Propagation Delay versus Trigger Voltage



MC3456

Figure 13. 1/2 Representative Circuit Schematic



GENERAL OPERATION

The MC3456 is a dual timing circuit which uses as its timing elements an external resistor/capacitor network. It can be used in both the monostable (one shot) and astable modes with frequency and duty cycle, controlled by the capacitor and resistor values. While the timing is dependent upon the external passive components, the monolithic circuit provides the starting circuit, voltage comparison and other functions needed for a complete timing circuit. Internal to the integrated circuit are two comparators, one for the input signal and the other for capacitor voltage; also a flip-flop and digital output are included. The comparator reference voltages are always a fixed ratio of the supply voltage thus providing output timing independent of supply voltage.

Monostable Mode

In the monostable mode, a capacitor and a single resistor are used for the timing network. Both the threshold terminal and the discharge transistor terminal are connected together in this mode (refer to circuit Figure 15). When the input voltage to the trigger comparator falls below $1/3 V_{CC}$ the comparator output triggers the flip-flop so that its output sets low. This turns the capacitor discharge transistor "off" and drives the digital output to the high state. This condition allows the capacitor to charge at an exponential rate which is set by the RC time constant. When the capacitor voltage reaches $2/3 V_{CC}$ the threshold comparator resets the flip-flop. This action discharges the timing capacitor and returns the digital output to the low state. Once the flip-flop has been triggered by an input signal, it cannot be retriggered until the present timing period has been completed. The time

that the output is high is given by the equation $t = 1.1 R_A C$. Various combinations of R and C and their associated times are shown in Figure 14. The trigger pulse width must be less than the timing period.

A reset pin is provided to discharge the capacitor thus interrupting the timing cycle. As long as the reset pin is low, the capacitor discharge transistor is turned "on" and prevents the capacitor from charging. While the reset voltage is applied the digital output will remain the same. The reset pin should be tied to the supply voltage when not in use.

Figure 14. Time Delay

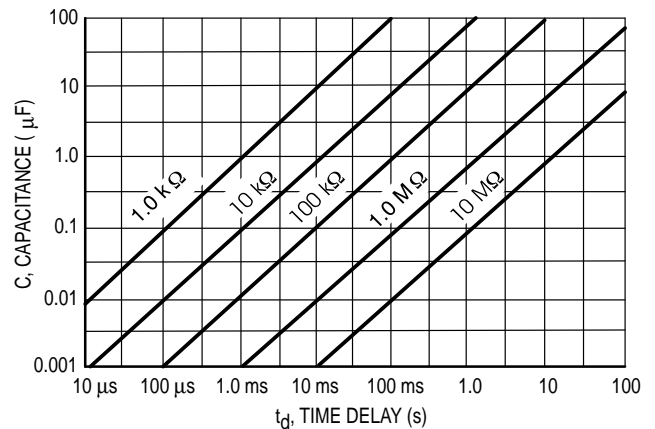

MC3456

Figure 15. Monostable Circuit

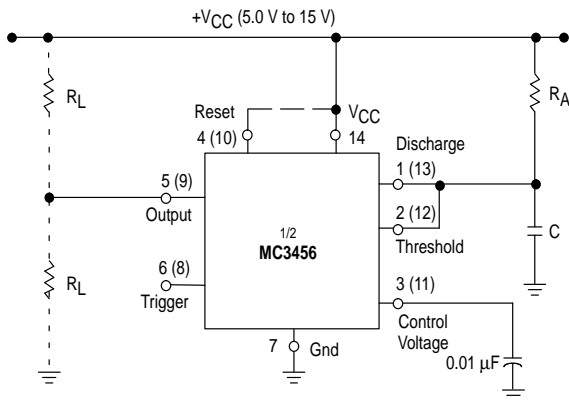

Pin numbers in parenthesis () indicate B-Channel

Figure 16. Monostable Waveforms

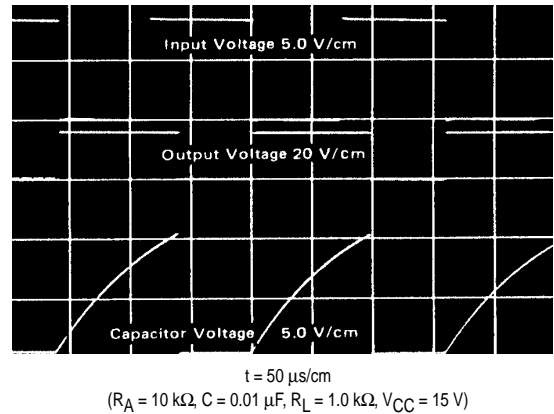

Figure 17. Astable Circuit

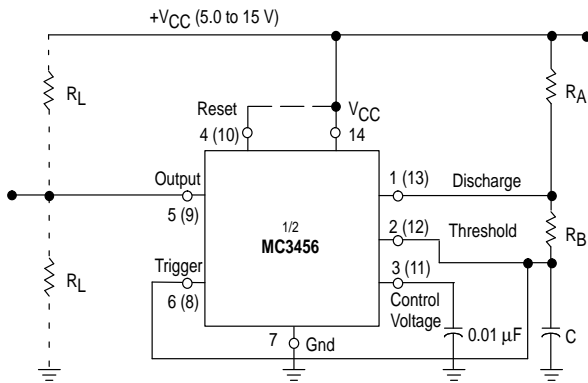
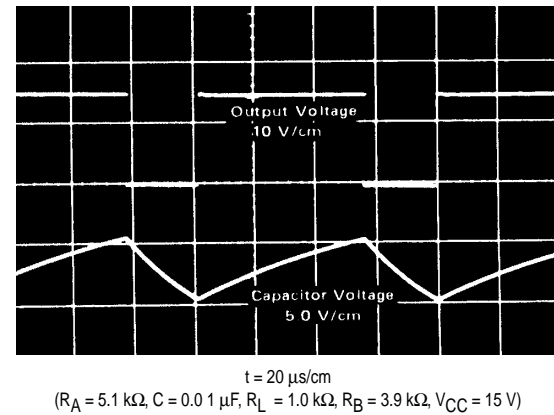

Figure 18. Astable Waveforms



Astable Mode

In the astable mode the timer is connected so that it will retrigger itself and cause the capacitor voltage to oscillate between $1/3 V_{CC}$ and $2/3 V_{CC}$ (see Figure 17).

The external capacitor charges to $2/3 V_{CC}$ through R_A and R_B and discharges to $1/3 V_{CC}$ through R_B . By varying the ratio of these resistors the duty cycle can be varied. The charge and discharge times are independent of the supply voltage.

The charge time (output high) is given by:
 $t_1 = 0.695 (R_A + R_B) C$

The discharge time (output low) by:
 $t_2 = 0.695 (R_B) C$

Thus the total period is given by:
 $T = t_1 + t_2 = 0.695 (R_A + 2R_B) C$

The frequency of oscillation is then: $f = \frac{1}{T} = \frac{1.44}{(R_A + 2R_B) C}$

and may be easily found as shown in Figure 19.

The duty cycle is given by: $DC = \frac{R_B}{R_A + 2R_B}$

To obtain the maximum duty cycle, R_A must be as small as possible; but it must also be large enough to limit the

discharge current (Pin 7 current) within the maximum rating of the discharge transistor (200 mA).

The minimum value of R_A is given by:

$$R_A \geq \frac{V_{CC} (V_{dc})}{I_7 (A)} \geq \frac{V_{CC} (V_{dc})}{0.2}$$

Figure 19. Free Running Frequency

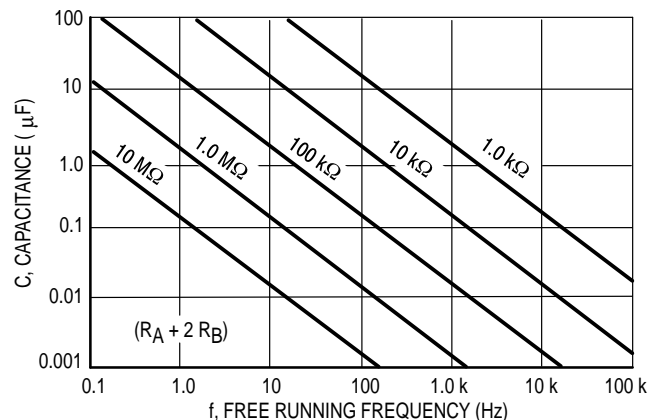

MC3456

APPLICATIONS INFORMATION

Tone Burst Generator

For a tone burst generator, the first timer is used as a monostable and determines the tone duration when triggered by a positive pulse at Pin 6. The second timer is enabled by the high output of the monostable. It is connected as an astable and determines the frequency of the tone.

Dual Astable Multivibrator

This dual astable multivibrator provides versatility not available with single timer circuits. The duty cycle can be adjusted from 5% to 95%. The two outputs provide two phase clock signals often required in digital systems. It can also be inhibited by use of either reset terminal.

Figure 20. Tone Burst Generator

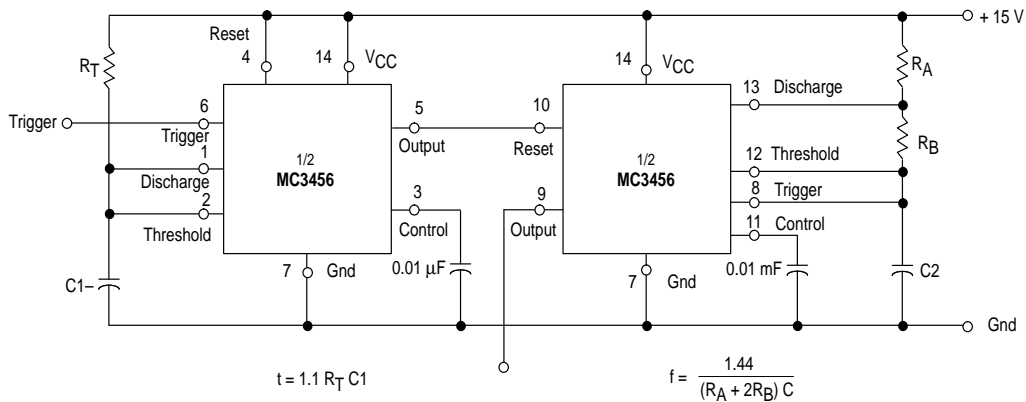
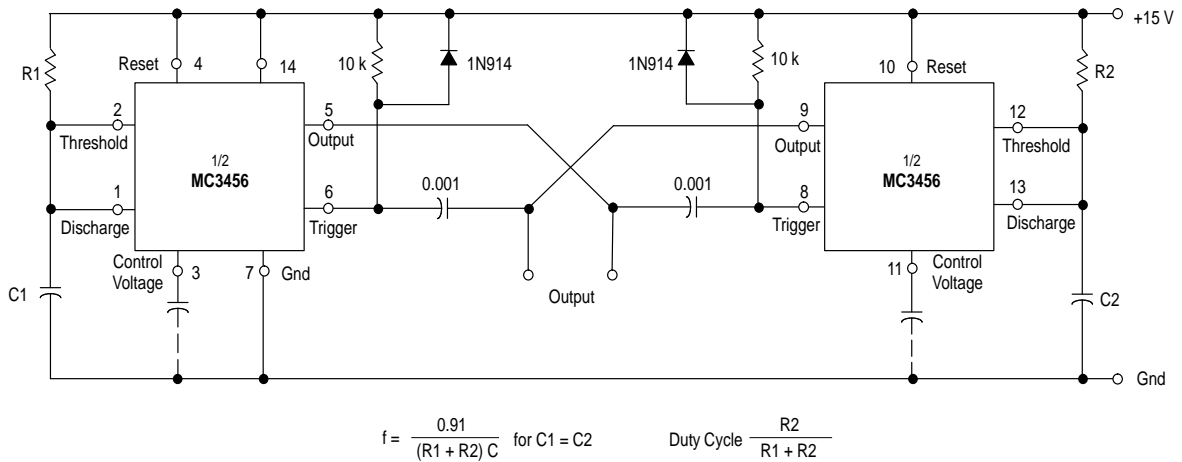

Figure 21. Dual Astable Multivibrator



MC3456

Pulse Width Modulation

If the timer is triggered with a continuous pulse train in the monostable mode of operation, the charge time of the capacitor can be varied by changing the control voltage at Pin 3. In this manner, the output pulse width can be modulated by applying a modulating signal that controls the threshold voltage.

Test Sequences

Several timers can be connected to drive each other for sequential timing. An example is shown in Figure 24 where the sequence is started by triggering the first timer which runs for 10 ms. The output then switches low momentarily and starts the second timer which runs for 50 ms and so forth.

Figure 22. Pulse Width Modulation Waveforms

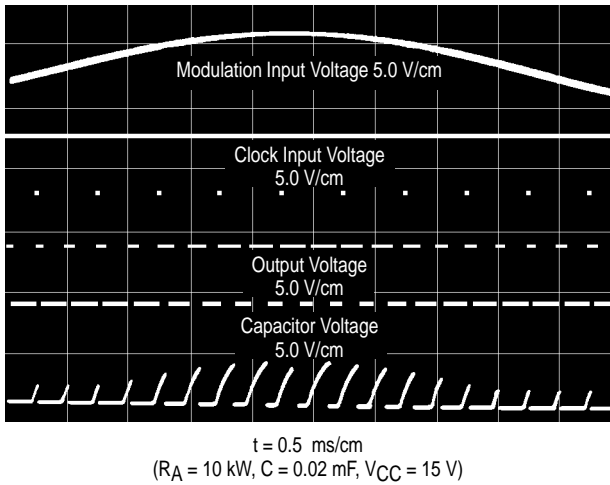

Figure 23. Pulse Width Modulation Circuit

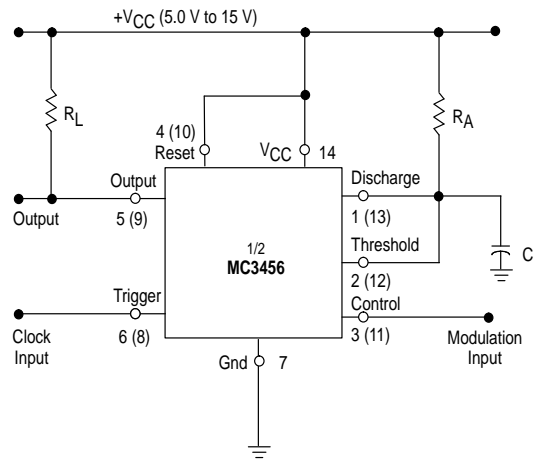
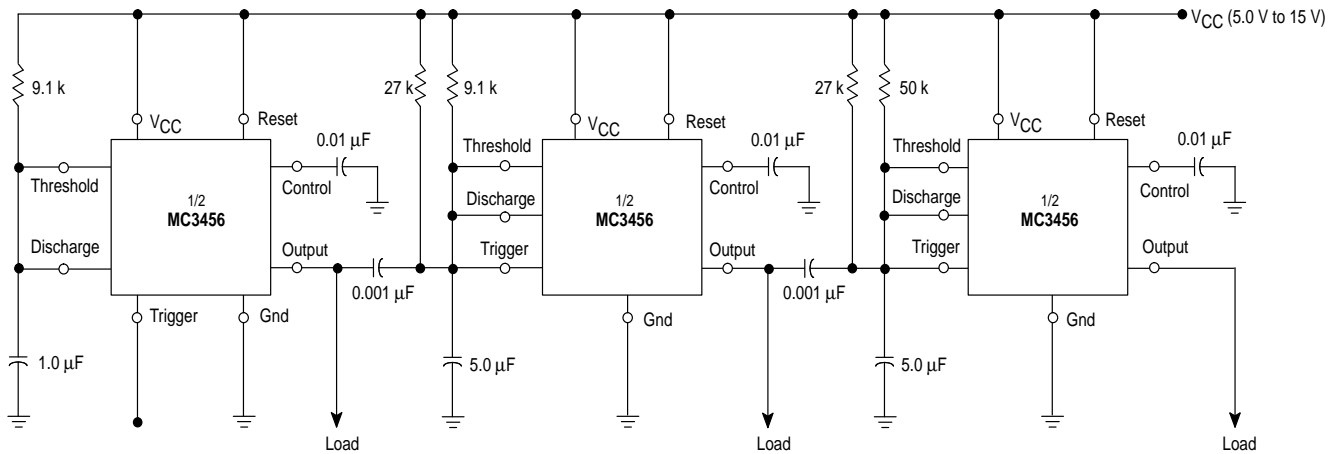
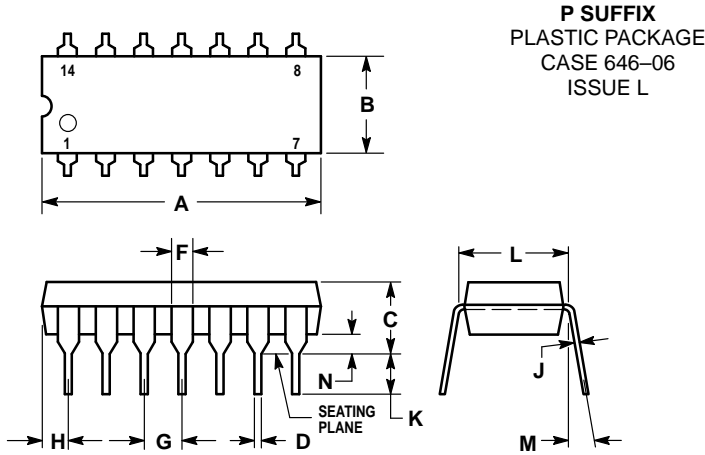

Figure 24. Sequential Timing Circuit



MC3456

OUTLINE DIMENSIONS



NOTES:

- LEADS WITHIN 0.13 (0.005) RADIUS OF TRUE POSITION AT SEATING PLANE AT MAXIMUM MATERIAL CONDITION.
- DIMENSION L TO CENTER OF LEADS WHEN FORMED PARALLEL.
- DIMENSION B DOES NOT INCLUDE MOLD FLASH.
- ROUNDED CORNERS OPTIONAL.

DIM	INCHES		MILLIMETERS	
	MIN	MAX	MIN	MAX
A	0.715	0.770	18.16	19.56
B	0.240	0.260	6.10	6.60
C	0.145	0.185	3.69	4.69
D	0.015	0.021	0.38	0.53
F	0.040	0.070	1.02	1.78
G	0.100 BSC		2.54 BSC	
H	0.052	0.095	1.32	2.41
J	0.008	0.015	0.20	0.38
K	0.115	0.135	2.92	3.43
L	0.300 BSC		7.62 BSC	
M	0°	10°	0°	10°
N	0.015	0.039	0.39	1.01

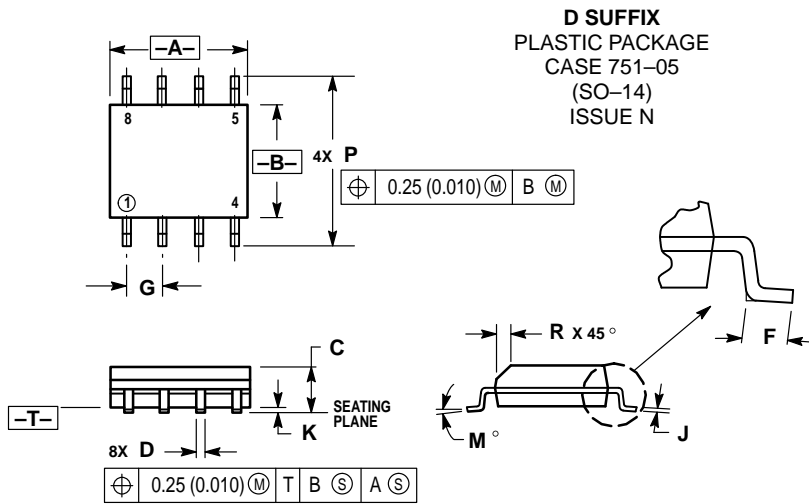

NOTES:

- DIMENSIONING AND TOLERANCING PER ANSI Y14.5M, 1982.
- CONTROLLING DIMENSION: MILLIMETER.
- DIMENSIONS A AND B DO NOT INCLUDE MOLD PROTRUSION.
- MAXIMUM MOLD PROTRUSION 0.15 (0.006) PER SIDE.
- DIMENSION D DOES NOT INCLUDE DAMBAR PROTRUSION. ALLOWABLE DAMBAR PROTRUSION SHALL BE 0.127 (0.005) TOTAL IN EXCESS OF THE D DIMENSION AT MAXIMUM MATERIAL CONDITION.

DIM	MILLIMETERS		INCHES	
	MIN	MAX	MIN	MAX
A	4.80	5.00	0.189	0.196
B	3.80	4.00	0.150	0.157
C	1.35	1.75	0.054	0.068
D	0.35	0.49	0.014	0.019
F	0.40	1.25	0.016	0.049
G	1.27 BSC		0.050 BSC	
J	0.18	0.25	0.007	0.009
K	0.10	0.25	0.004	0.009
M	0°	7°	0°	7°
P	5.80	6.20	0.229	0.244
R	0.25	0.50	0.010	0.019



MC3456

Motorola reserves the right to make changes without further notice to any products herein. Motorola makes no warranty, representation or guarantee regarding the suitability of its products for any particular purpose, nor does Motorola assume any liability arising out of the application or use of any product or circuit, and specifically disclaims any and all liability, including without limitation consequential or incidental damages. "Typical" parameters which may be provided in Motorola data sheets and/or specifications can and do vary in different applications and actual performance may vary over time. All operating parameters, including "Typicals" must be validated for each customer application by customer's technical experts. Motorola does not convey any license under its patent rights nor the rights of others. Motorola products are not designed, intended, or authorized for use as components in systems intended for surgical implant into the body, or other applications intended to support or sustain life, or for any other application in which the failure of the Motorola product could create a situation where personal injury or death may occur. Should Buyer purchase or use Motorola products for any such unintended or unauthorized application, Buyer shall indemnify and hold Motorola and its officers, employees, subsidiaries, affiliates, and distributors harmless against all claims, costs, damages, and expenses, and reasonable attorney fees arising out of, directly or indirectly, any claim of personal injury or death associated with such unintended or unauthorized use, even if such claim alleges that Motorola was negligent regarding the design or manufacture of the part. Motorola and  are registered trademarks of Motorola, Inc. Motorola, Inc. is an Equal Opportunity/Affirmative Action Employer.

How to reach us:

USA/EUROPE/Locations Not Listed: Motorola Literature Distribution;
P.O. Box 20912; Phoenix, Arizona 85036. 1-800-441-2447 or 602-303-5454

MFAX: RMFAX0@email.sps.mot.com – TOUCHTONE 602-244-6609
INTERNET: <http://Design-NET.com>

JAPAN: Nippon Motorola Ltd.; Tatsumi-SPD-JLDC, 6F Seibu-Butsuryu-Center,
3-14-2 Tatsumi Koto-Ku, Tokyo 135, Japan. 03-81-3521-8315

ASIA/PACIFIC: Motorola Semiconductors H.K. Ltd.; 8B Tai Ping Industrial Park,
51 Ting Kok Road, Tai Po, N.T., Hong Kong. 852-26629298

