



September 2005

LM4702 Overture® Audio Power Amplifier Series Stereo High Fidelity 200 Volt* Driver with Mute

General Description

The LM4702 is a high fidelity audio power amplifier driver designed for demanding consumer and pro-audio applications. Amplifier output power may be scaled by changing the supply voltage and number of output devices. The LM4702 is capable of delivering in excess of 300 watts per channel single ended into an 8 ohm load in the presence of 10% high line headroom and 20% supply regulation.

The LM4702 includes thermal shut down circuitry that activates when the die temperature exceeds 150°C. The LM4702's mute function, when activated, mutes the input drive signal and forces the amplifier output to a quiescent state.

The LM4702 is available in 3 grades that span a wide range of applications and performance levels. The LM4702C is targeted at high volume applications. The LM4702B (in development) includes a higher voltage rating along with the tighter specifications. The LM4702A (in development) is the premium part with the highest voltage rating, fully specified with limits over voltage and temperature, and is offered in a military 883 compliant TO-3 package.

* Tentative Max Operating voltage for the LM4702A, LM4702B (in development)

Key Specifications

- Wide operating voltage range

LM4702A (in development)	±20V to ±85V
LM4702B (in development)	±20V to ±80V
LM4702C	±20V to ±75V
- Equivalent Noise 3µV
- PSRR 110dB (typ)
- THD 0.001%

Features

- Very high voltage operation
- Scalable output power
- Minimum external components
- External compensation
- Thermal Shutdown and Mute

Applications

- AV receivers
- Audiophile power amps
- Pro Audio
- High voltage industrial applications

Typical Application and Connection Diagrams

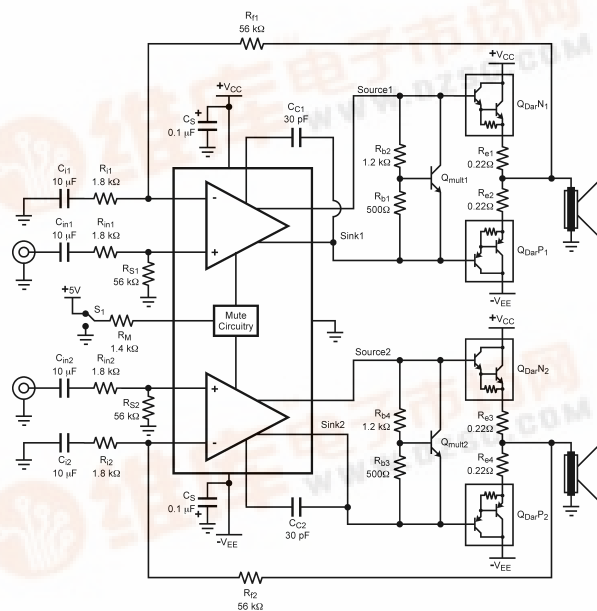
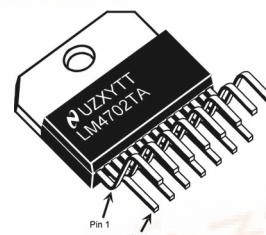

FIGURE 1. Typical Audio Amplifier Application Circuit



20158302
Plastic Package — 15 Lead TO-220
(for LM4702; LM4702B, in development)



20158320
Metal Can — 15 Lead TO-3
(for LM4702A, in development)

LM4702 Overture® Stereo High Fidelity 200 Volt* Driver with Mute



Typical Application and Connection Diagrams (Continued)

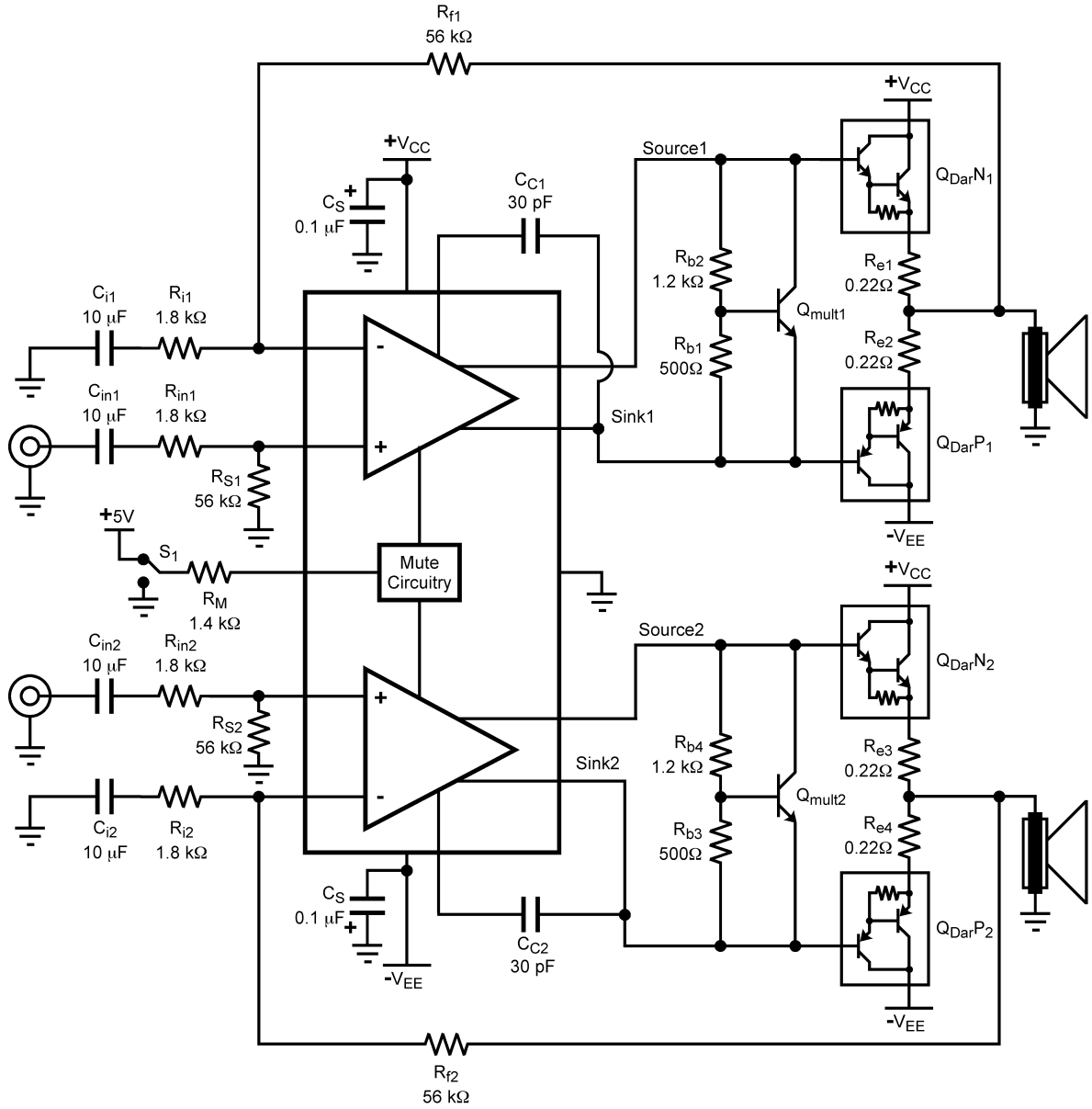

FIGURE 1. Typical Audio Amplifier Application Circuit

20158319



Connection Diagram

Plastic Package (For B and C) (Note 13)

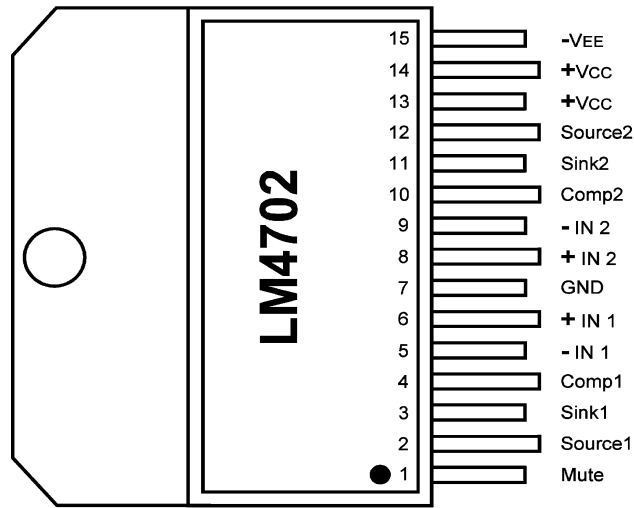

20158301

Top View
Order Number LM4702T(B & C)
See NS Package Number TA15A



Absolute Maximum Ratings (Notes 1, 2)

If Military/Aerospace specified devices are required, please contact the National Semiconductor Sales Office/Distributors for availability and specifications.

Supply Voltage $ V^+ + V^- $	200V
Differential Input Voltage	+/-6V
Common Mode Input Range	0.4 V _{ee} to 0.4 V _{cc}
Power Dissipation (Note 3)	4W
ESD Susceptibility (Note 4)	1.5kV
ESD Susceptibility (Note 5)	200V
Junction Temperature (T _{JMAX}) (Note 9)	150°C
Soldering Information	
T Package (10 seconds)	260°C

Storage Temperature	-40°C to +150°C
Thermal Resistance	
θ_{JA}	30°C/W
θ_{JC}	1°C/W

Operating Ratings (Notes 1, 2)

Temperature Range	
T _{MIN} ≤ T _A ≤ T _{MAX}	-20°C ≤ T _A ≤ +75°C
Supply Voltage $ V^+ + V^- $	
LM4702A (in development)	+/-20V ≤ V _{TOTAL} ≤ +/-85V
LM4702B (in development)	+/-20V ≤ V _{TOTAL} ≤ +/-80V
LM4702C	+/-20V ≤ V _{TOTAL} ≤ +/-75V

Electrical Characteristics (LM4702C) V_{cc} = +75V, V_{ee} = -75V (Notes 1, 2)

The following specifications apply for I_{MUTE} = 1.5mA, unless otherwise specified. Limits apply for T_A = 25°C.

Symbol	Parameter	Conditions	LM4702		Units (Limits)
			Typical (Note 6)	Limit (Notes 7, 8)	
I _{CC}	Total Quiescent Power Supply Current	V _{CM} = 0V, V _O = 0V, I _O = 0A	25	30	mA (max)
THD+N	Total Harmonic Distortion + Noise	No load, A _V = 30dB V _{OUT} = 14V _{RMS} @ 1kHz	0.005		%
R _S	Input Bias Resistor		50	100	kΩ (max)
A _V	Closed Loop Voltage Gain			26	dB (min)
A _V open	Open Loop Gain	V _{in} = 1mV _{rms} , f = 1KHz, C = 30pF	93		dB
V _{om}	Output Voltage Swing	THD = 0.05%, Freq = 20Hz to 20KHz	51		V _{rms} (min)
V _{noise}	Output Noise	R _s = 10kΩ, LPF = 30kHz, A _V = 30dB A-weighted	150	300	μV (max)
			90		μV
I _{OUT}	Output Current	Current from Source to Sink Pins	5.5	3	mA(min)
				10	mA (max)
I _{mute}	Current into Mute Pin	To put part in "play" mode	1.5	1	mA(min)
				2	mA (max)
X _{TALK}	Channel Separation (Note 11)	f = 1kHz @ A _V = 30dB	85		dB
SR	Slew Rate	V _{IN} = 1.2V _{P-P} , f = 10kHz square Wave, Outputs shorted	15		V/μs
V _{OS}	Input Offset Voltage	V _{CM} = 0V, I _O = 0mA	10	35	mV (max)
I _B	Input Bias Current	V _{CM} = 0V, I _O = 0mA	500		nA
PSRR	Power Supply Rejection Ratio	R _s = 1k, f = 100Hz, V _{ripple} = 1V _{rms} , Input Referred	110	95	dB (min)

Electrical Characteristics (LM4702C) V_{cc} = +50V, V_{ee} = -50V (Notes 1, 2)

The following specifications apply for I_{MUTE} = 1.5mA, unless otherwise specified. Limits apply for T_A = 25°C.

Symbol	Parameter	Conditions	LM4702		Units (Limits)
			Typical (Note 6)	Limit (Notes 7, 8)	
I _{CC}	Total Quiescent Power Supply Current	V _{CM} = 0V, V _O = 0V, I _O = 0A	22	30	mA (max)
THD+N	Total Harmonic Distortion + Noise	No load, A _V = 30dB V _{OUT} = 10V _{RMS} @ 1kHz	0.005		%
R _S	Input Bias Resistor		50	100	kΩ (max)



Electrical Characteristics (LM4702C) $V_{CC} = +50V$, $V_{EE} = -50V$ (Notes 1,

2) (Continued)

The following specifications apply for $I_{MUTE} = 1.5mA$, unless otherwise specified. Limits apply for $T_A = 25^\circ C$.

Symbol	Parameter	Conditions	LM4702		Units (Limits)
			Typical (Note 6)	Limit (Notes 7, 8)	
A_V	Closed Loop Voltage Gain			26	dB (min)
$A_{V\ open}$	Open Loop Gain	$V_{IN} = 1mV_{rms}$, $f = 1kHz$, $C = 30pF$	93		dB
V_{om}	Output Voltage Swing	THD = 0.05%, Freq = 20Hz to 20KHz	33		Vrms (min)
V_{noise}	Output Noise	$R_s = 10k\Omega$, LPF = 30kHz, $A_V = 30dB$ A-weighted	150	300	μV (max)
			90		μV
I_{OUT}	Output Current	Outputs Shorted	5.2	3	mA(min)
				10	mA (max)
I_{mute}	Current into Mute Pin	To put part in "play" mode	1.5	1	mA(min)
				2	mA (max)
X_{TALK}	Channel Separation (Note 11)	$f = 1kHz$ at $A_V = 30dB$	85		dB
SR	Slew Rate	$V_{IN} = 1.2V_{P-P}$, $f = 10kHz$ square Wave, Outputs shorted	15		V/ μs
V_{OS}	Input Offset Voltage	$V_{CM} = 0V$, $I_O = 0mA$	10	35	mV (max)
I_B	Input Bias Current	$V_{CM} = 0V$, $I_O = 0mA$	500		nA
PSRR	Power Supply Rejection Ratio	$R_s = 1k$, $f = 100Hz$, Vripple = 1Vrms, Input Referred	110	95	dB (min)

Electrical Characteristics (LM4702B) $V_{CC} = +80V$, $V_{EE} = -80V$ (Pre-release information) (Notes 1, 2)

The following specifications apply for $I_{MUTE} = 1.5mA$, unless otherwise specified. Limits apply for $T_A = 25^\circ C$.

Symbol	Parameter	Conditions	LM4702		Units (Limits)
			Typical (Note 6)	Limit (Notes 7, 8)	
I_{CC}	Total Quiescent Power Supply Current	$V_{CM} = 0V$, $V_O = 0V$, $I_O = 0A$	27	TBD	mA (max)
THD+N	Total Harmonic Distortion + Noise	No load, $A_V = 30dB$ $V_{OUT} = 20V_{RMS}$ @ 1kHz	0.003	TBD	% (max)
R_S	Input Bias Resistor		50	TBD	k Ω (max)
A_V	Closed Loop Voltage Gain			TBD	dB (min)
$A_{V\ open}$	Open Loop Gain	$V_{IN} = 1mV_{rms}$, $f = 1kHz$, $C = 30pF$	93		dB
V_{om}	Output Voltage Swing	THD = 0.05%, Freq = 20Hz to 20KHz	54	TBD	Vrms (min)
V_{noise}	Output Noise	$R_s = 10k\Omega$, LPF = 30kHz, $A_V = 30dB$ A-weighted	150	TBD	μV (max)
			90	TBD	
I_{OUT}	Output Current	Outputs Shorted	5.5	TBD	mA(min)
				TBD	mA (max)
I_{mute}	Current into Mute Pin	To put part in "play" mode	1.5	TBD	mA(min)
				TBD	mA (max)
X_{TALK}	Channel Separation (Note 11)	$f = 1kHz$ at $A_V = 30dB$	85	TBD	dB (min)
SR	Slew Rate	$V_{IN} = 1.2V_{P-P}$, $f = 10kHz$ square Wave, Outputs shorted	17	TBD	V/ μs (min)
V_{OS}	Input Offset Voltage	$V_{CM} = 0V$, $I_O = 0mA$	7	TBD	mV (max)
I_B	Input Bias Current	$V_{CM} = 0V$, $I_O = 0mA$	350	TBD	nA (max)
PSRR	Power Supply Rejection Ratio	$R_s = 1k$, $f = 100Hz$, Vripple = 1Vrms, Input Referred	110	TBD	dB (min)



Electrical Characteristics (LM4702A) $V_{CC} = +85V$, $V_{EE} = -85V$ (Pre-release information) (Notes 1, 2)

The following specifications apply for $I_{MUTE} = 1.5mA$, unless otherwise specified. Limits apply for $T_A = 25^\circ C$.

Symbol	Parameter	Conditions	LM4702		Units (Limits)
			Typical (Note 6)	Limit (Notes 7, 8)	
I_{CC}	Total Quiescent Power Supply Current	$V_{CM} = 0V$, $V_O = 0V$, $I_O = 0A$	27	TBD	mA (max)
THD+N	Total Harmonic Distortion + Noise	No load, $A_V = 30dB$ $V_{OUT} = 20V_{RMS}$ @ 1kHz	0.001	TBD	% (max)
R_S	Input Bias Resistor		50	TBD	k Ω (max)
A_V	Closed Loop Voltage Gain			TBD	dB (min)
A_V open	Open Loop Gain	$V_{in} = 1mV_{rms}$, $f = 1KHz$, $C = 30pF$	93		dB
V_{om}	Output Voltage Swing	THD = 0.05%, Freq = 20Hz to 20KHz	57	TBD	Vrms (min)
V_{noise}	Output Noise	$R_s = 10k\Omega$, LPF = 30kHz, $A_V = 30dB$ A-weighted	100 80	TBD TBD	μV (max)
I_{OUT}	Output Current	Outputs Shorted	5.5	TBD TBD	mA(min) mA (max)
I_{mute}	Current into Mute Pin	To put part in "play" mode	1.5	TBD TBD	mA(min) mA (max)
X_{TALK}	Channel Separation (Note 11)	$f = 1kHz$ at $A_V = 30dB$	90	TBD	dB (min)
SR	Slew Rate	$V_{IN} = 1.2V_{P-P}$, $f = 10kHz$ square Wave, Outputs shorted	TBD	TBD	V/ μs (min)
V_{OS}	Input Offset Voltage	$V_{CM} = 0V$, $I_O = 0mA$	5	TBD	mV (max)
I_B	Input Bias Current	$V_{CM} = 0V$, $I_O = 0mA$	150	TBD	nA (max)
PSRR	Power Supply Rejection Ratio	$R_s = 1k$, $f = 100Hz$, Vripple = 1Vrms, Input Referred	110	TBD	dB (min)

Note 1: All voltages are measured with respect to the ground pins, unless otherwise specified.

Note 2: Absolute Maximum Ratings indicate limits beyond which damage to the device may occur. Operating Ratings indicate conditions for which the device is functional, but do not guarantee specific performance limits. Electrical Characteristics state DC and AC electrical specifications under particular test condition which guarantee specific performance limits. This assumes that the device is within the Operating Ratings. Specifications are not guaranteed for parameters where no limit is given. However, the typical value is a good indication of device's performance.

Note 3: The maximum power dissipation must be de-rated at elevated temperatures and is dictated by T_{JMAX} , θ_{JC} , and the ambient temperature T_A . The maximum allowable power dissipation is $P_{DMAX} = (T_{JMAX} - T_A)/\theta_{JC}$ or the number given in the Absolute Maximum Ratings, whichever is lower. For the LM4702, $T_{JMAX} = 150^\circ C$ and the typical θ_{JC} is $1^\circ C/W$. Refer to the **Thermal Considerations** section for more information.

Note 4: Human body model, 100pF discharged through a 1.5k Ω resistor.

Note 5: Machine Model: a 220pF - 240pF discharged through all pins.

Note 6: Typical specifications are measured at $25^\circ C$ and represent the parametric norm.

Note 7: Tested limits are guaranteed to National's AOQL (Average Outgoing Quality Level).

Note 8: Datasheet min/max specification limits are guaranteed by design, test, or statistical analysis.

Note 9: The maximum operating junction temperature is $150^\circ C$.

Note 10: PCB layout will affect cross talk. It is recommended that input and output traces be separated by as much distance as possible. Return ground traces from outputs should be independent back to a single ground point and use as wide of traces as possible.

Note 11: The TA15A is a non-isolated package. The package's metal back and any heat sink to which it is mounted are connected to the Vee potential when using only thermal compound. If a mica washer is used in addition to thermal compound, θ_{CS} (case to sink) is increased, but the heat sink will be electrically isolated from Vee.

Typical Performance Characteristics for LM4702C

THD+N vs Output Voltage
 $V_{DD} = \pm 50V$, $f = 1kHz$, outputs shorted

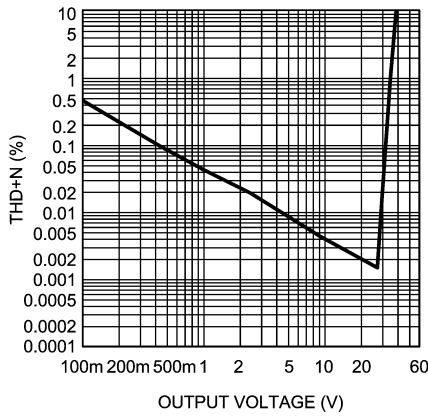

20158308

THD+N vs Output Voltage
 $V_{DD} = \pm 75V$, $f = 1kHz$, outputs shorted

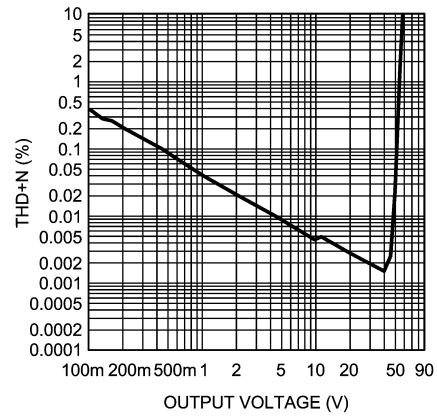

20158338

THD+N vs Frequency
 $V_{DD} = \pm 50V$, $V_{OUT} = 10V_{rms}$, outputs shorted

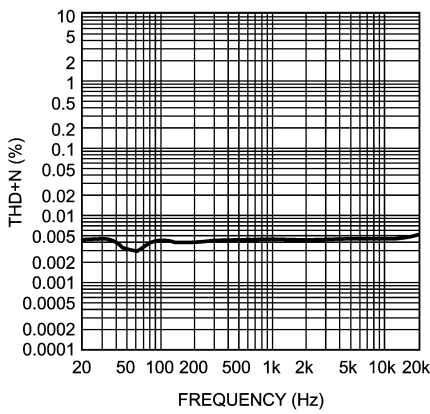

20158310

THD+N vs Frequency
 $V_{DD} = \pm 75V$, $V_{OUT} = 14V_{rms}$, outputs shorted

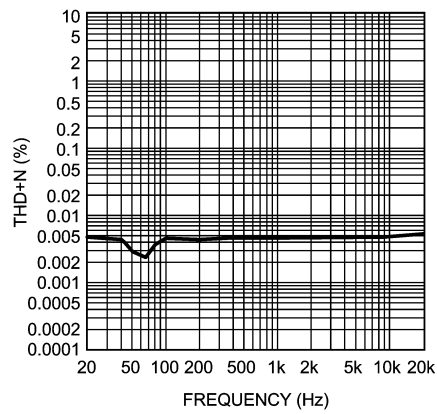

20158339

Crosstalk vs Frequency
 $V_{DD} = \pm 50V$

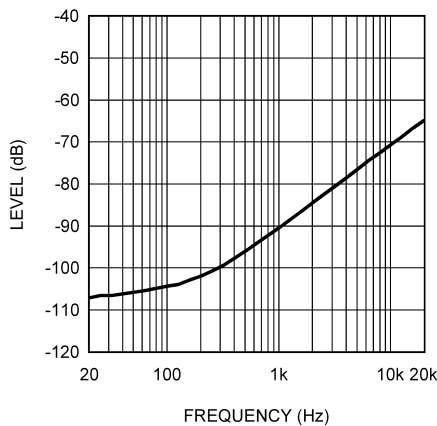

20158335

Crosstalk vs Frequency
 $V_{DD} = \pm 75V$

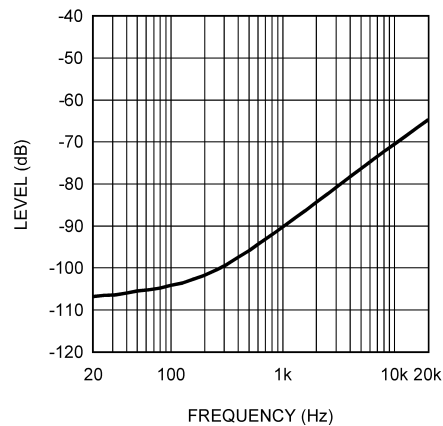

20158336



Typical Performance Characteristics for LM4702C (Continued)

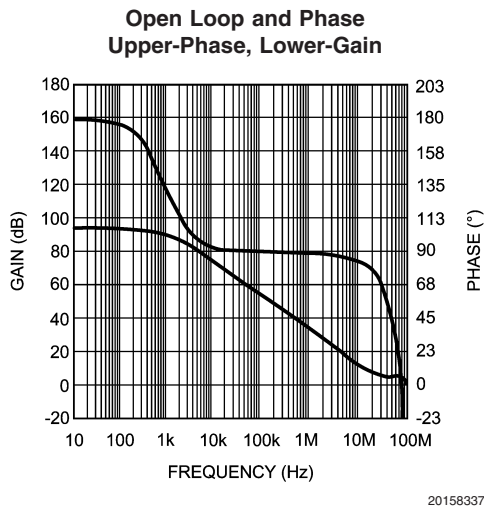
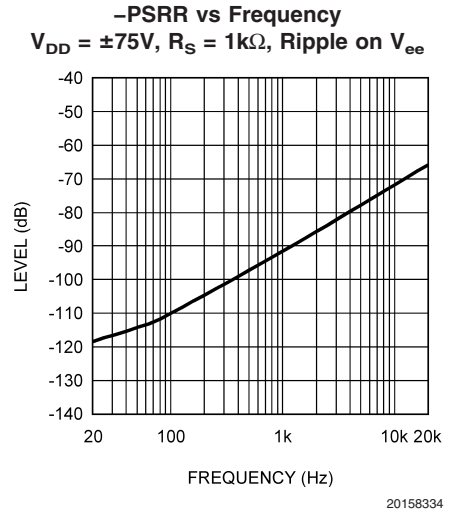
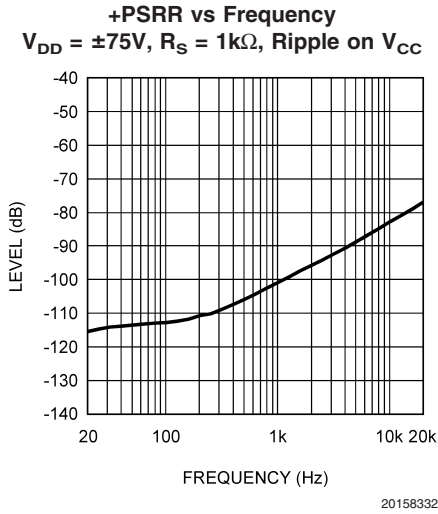
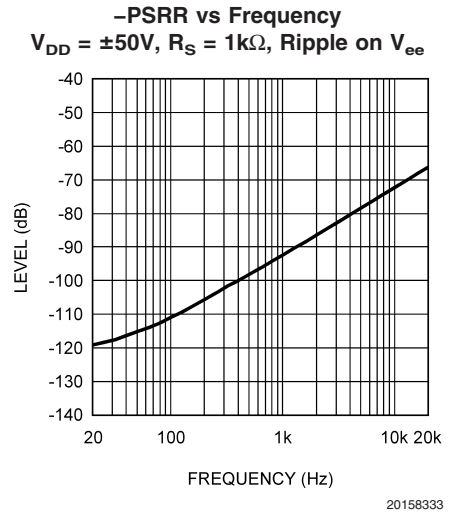
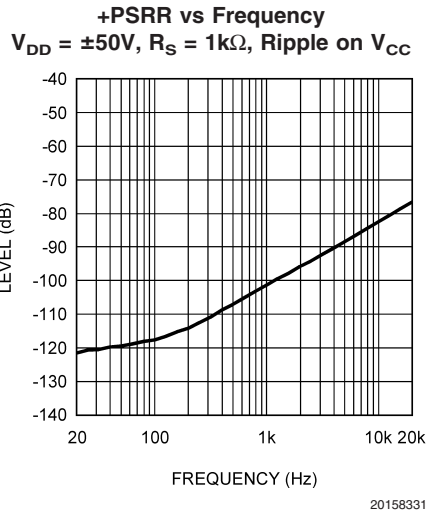

Test Circuit

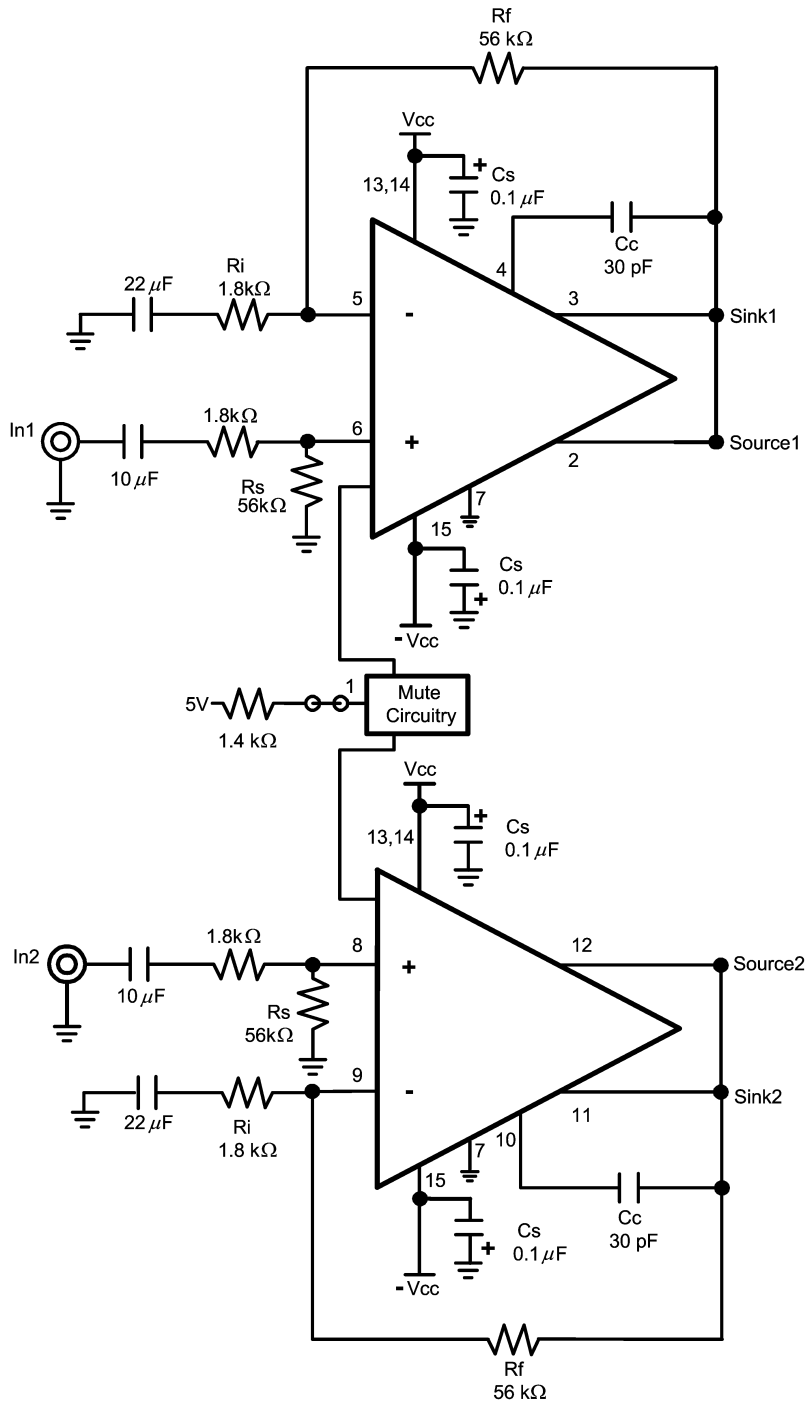

20158303

FIGURE 1.



Application Information

MUTE FUNCTION

The mute function of the LM4702 is controlled by the amount of current that flows into the mute pin. If there is less than 1mA of current flowing into the mute pin, the part will be in mute. This can be achieved by shorting the mute pin to ground or by floating the mute pin. If there is between 1mA and 2mA of current flowing into the mute pin, the part will be in “play” mode. This can be done by connecting a power supply (Vmute) to the mute pin through a resistor (Rm). The current into the mute pin can be determined by the equation $I_{\text{mute}} = (V_{\text{mute}} - 2.9) / R_m$. For example, if a 5V power supply is connected through a 1.4k resistor to the mute pin, then the mute current will be 1.5mA, at the center of the specified range. It is also possible to use Vcc as the power supply for the mute pin, though Rm will have to be recalculated accordingly. It is not recommended to flow more than 2mA of current into the mute pin because damage to the LM4702 may occur.

It is highly recommended to switch between mute and “play” modes rapidly. This is accomplished most easily through using a toggle switch that alternatively connects the mute pin through a resistor to either ground or the mute pin power supply. Slowly increasing the mute current may result in undesired voltages on the outputs of the LM4702, which can damage an attached speaker.

THERMAL PROTECTION

The LM4702 has a sophisticated thermal protection scheme to prevent long-term thermal stress of the device. When the temperature on the die exceeds 150°C, the LM4702 shuts down. It starts operating again when the die temperature drops to about 145°C, but if the temperature again begins to rise, shutdown will occur again above 150°C. Therefore, the device is allowed to heat up to a relatively high temperature if the fault condition is temporary, but a sustained fault will cause the device to cycle in a Schmitt Trigger fashion between the thermal shutdown temperature limits of 150°C and 145°C. This greatly reduces the stress imposed on the IC by thermal cycling, which in turn improves its reliability under sustained fault conditions.

Since the die temperature is directly dependent upon the heat sink used, the heat sink should be chosen so that thermal shutdown is not activated during normal operation. Using the best heat sink possible within the cost and space constraints of the system will improve the long-term reliability of any power semiconductor device, as discussed in the **Determining the Correct Heat Sink** section.

POWER DISSIPATION AND HEAT SINKING

When in “play” mode, the LM4702 draws a constant amount of current, regardless of the input signal amplitude. Consequently, the power dissipation is constant for a given supply voltage and can be computed with the equation $P_{\text{DMAX}} = I_{\text{cc}} * (V_{\text{cc}} - V_{\text{ee}})$. For a quick calculation of P_{DMAX} , approximate the current to be 25mA and multiply it by the total supply voltage (the current varies slightly from this value over the operating range).

DETERMINING THE CORRECT HEAT SINK

The choice of a heat sink for a high-power audio amplifier is made entirely to keep the die temperature at a level such that the thermal protection circuitry is not activated under normal circumstances.

The thermal resistance from the die to the outside air, θ_{JA} (junction to ambient), is a combination of three thermal resistances, θ_{JC} (junction to case), θ_{CS} (case to sink), and θ_{SA} (sink to ambient). The thermal resistance, θ_{JC} (junction to case), of the LM4702T is 0.8°C/W. Using Thermalloy Thermacote thermal compound, the thermal resistance, θ_{CS} (case to sink), is about 0.2°C/W. Since convection heat flow (power dissipation) is analogous to current flow, thermal resistance is analogous to electrical resistance, and temperature drops are analogous to voltage drops, the power dissipation out of the LM4702 is equal to the following:

$$P_{\text{DMAX}} = (T_{\text{JMAX}} - T_{\text{AMB}}) / \theta_{\text{JA}} \quad (1)$$

where $T_{\text{JMAX}} = 150^\circ\text{C}$, T_{AMB} is the system ambient temperature and $\theta_{\text{JA}} = \theta_{\text{JC}} + \theta_{\text{CS}} + \theta_{\text{SA}}$.

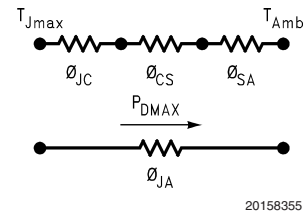

Once the maximum package power dissipation has been calculated using equation 2, the maximum thermal resistance, θ_{SA} , (heat sink to ambient) in °C/W for a heat sink can be calculated. This calculation is made using equation 4 which is derived by solving for θ_{SA} in equation 3.

$$\theta_{\text{SA}} = [(T_{\text{JMAX}} - T_{\text{AMB}}) - P_{\text{DMAX}}(\theta_{\text{JC}} + \theta_{\text{CS}})] / P_{\text{DMAX}} \quad (2)$$

Again it must be noted that the value of θ_{SA} is dependent upon the system designer’s amplifier requirements. If the ambient temperature that the audio amplifier is to be working under is higher than 25°C, then the thermal resistance for the heat sink, given all other things are equal, will need to be smaller.

PROPER SELECTION OF EXTERNAL COMPONENTS

Proper selection of external components is required to meet the design targets of an application. The choice of external component values that will affect gain and low frequency response are discussed below.

The gain of each amplifier is set by resistors R_f and R_i for the non-inverting configuration shown in Figure 1. The gain is found by Equation (3) below:

$$A_v = 1 + R_f / R_i \quad (\text{V/V}) \quad (3)$$

For best noise performance, lower values of resistors are used. A value of 1kΩ is commonly used for R_i and then setting the value of R_f for the desired gain. For the LM4702 the gain should be set no lower than 26dB. Gain settings below 26dB may experience instability.

The combination of R_i with C_i (see Figure 1) creates a high pass filter. The low frequency response is determined by these two components. The -3dB point can be found from Equation (4) shown below:

$$f_i = 1 / (2\pi R_i C_i) \quad (\text{Hz}) \quad (4)$$

If an input coupling capacitor is used to block DC from the inputs as shown in Figure 5, there will be another high pass filter created with the combination of C_{IN} and R_{IN} . When using an input coupling capacitor R_{IN} is needed to set the DC



Application Information (Continued)

bias point on the amplifier's input terminal. The resulting -3dB frequency response due to the combination of C_{IN} and R_{IN} can be found from *Equation (5)* shown below:

$$f_{IN} = 1 / (2\pi R_{IN} C_{IN}) \text{ (Hz)} \quad (5)$$

With large values of R_{IN} oscillations may be observed on the outputs when the inputs are left floating. Decreasing the value of R_{IN} or not letting the inputs float will remove the oscillations. If the value of R_{IN} is decreased then the value of C_{IN} will need to increase in order to maintain the same -3dB frequency response.

AVOIDING THERMAL RUNAWAY WHEN USING BIPOLAR OUTPUT STAGES

When using a bipolar output stage with the LM4702 (as in Figure 1), the designer must beware of thermal runaway. Thermal runaway is a result of the temperature dependence of V_{be} (an inherent property of the transistor). As temperature increases, V_{be} decreases. In practice, current flowing through a bipolar transistor heats up the transistor, which lowers the V_{be} . This in turn increases the current again, and the cycle repeats. If the system is not designed properly, this positive feedback mechanism can destroy the bipolar transistors used in the output stage.

One of the recommended methods of preventing thermal runaway is to use a heat sink on the bipolar output transistors. This will keep the temperature of the transistors lower. A second recommended method is to use emitter degeneration resistors (see R_{e1} , R_{e2} , R_{e3} , R_{e4} in Figure 1). As current increases, the voltage across the emitter degeneration resistor also increases, which decreases the voltage across the base and emitter. This mechanism helps to limit the current and counteracts thermal runaway.

A third recommended method is to use a "Vbe multiplier" to bias the bipolar output stage (see Figure 1). The Vbe multiplier consists of a bipolar transistor (Q_{mult} , see Figure 1) and two resistors, one from the base to the collector (R_{b2} , R_{b4} , see Figure 1) and one from the base to the emitter (R_{b1} , R_{b3} , see Figure 1). The voltage from the collector to the emitter (also the bias voltage of the output stage) is $V_{bias} = V_{be}(1+R_{b2}/R_{b1})$, which is why this circuit is called the Vbe multiplier. When Vbe multiplier transistor (Q_{mult} , see Figure 1) is mounted to the same heat sink as the bipolar output transistors, its temperature will track that of the output transistors. Its V_{be} is dependent upon temperature as well, and so it will draw more current as the output transistors heat it up. This will limit the base current into the output transistors, which counteracts thermal runaway.



LM4702 Demo Board Artwork

Top Overlay

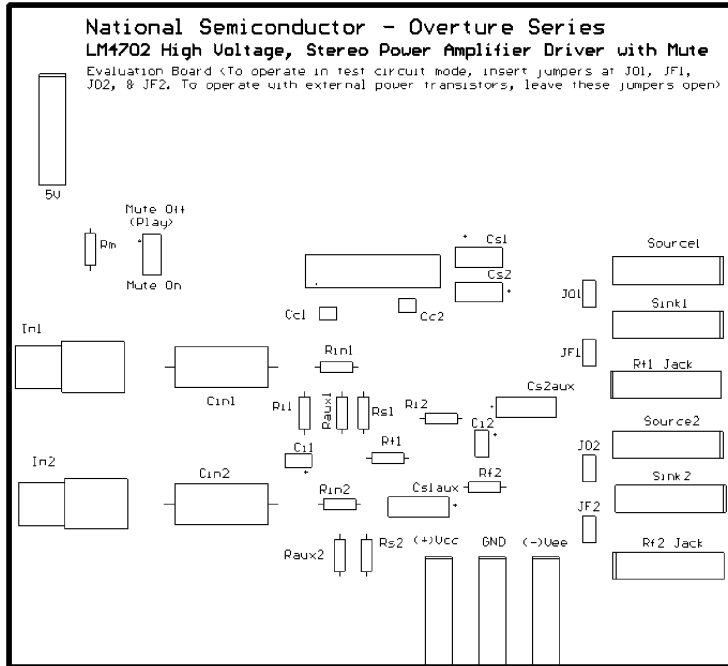

20158330

Top Layer

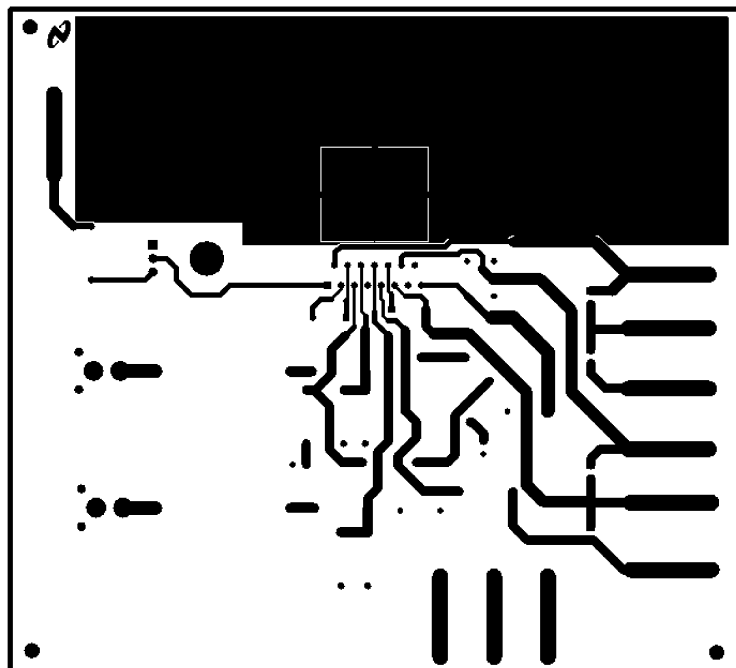

20158329



LM4702 Demo Board Artwork (Continued)

Bottom Layer

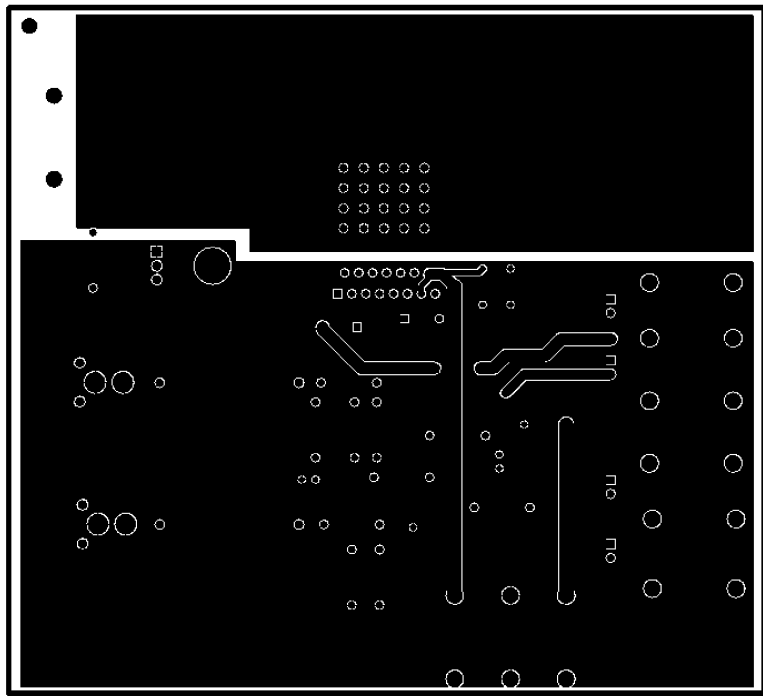

20158328



Revision History

Rev	Date	Description
1.0	8/18/05	Input corrected data under the Typical and Limit columns on all the 4 EC tables (per Kevin H.).
1.1	8/22/05	Changed limits back on LM4702A/B/C to $\pm 85V/80V/75V$ respectively (under Key Spec...)
1.2	8/31/05	First WEB released of the datasheet.
1.3	9/2/05	Due to miscommunication with the ASSY plant (EM), the datasheet needs to be taken off the WEB for now (per Robin Simpson).
1.4	9/09/05	Taken out Limits on Vom (under the +75V and +50V.. LM4702C EC tables), then released D/S to the WEB (per Robin Simpson).
1.5	9/14/05	Changed TM to R (Overture R) in the doc title (per Kevin C), Naomi Mitchell called Kevin about it.
1.6	9/15/05	Re-released D/S to the WEB with Overture "R".



Physical Dimensions inches (millimeters) unless otherwise noted

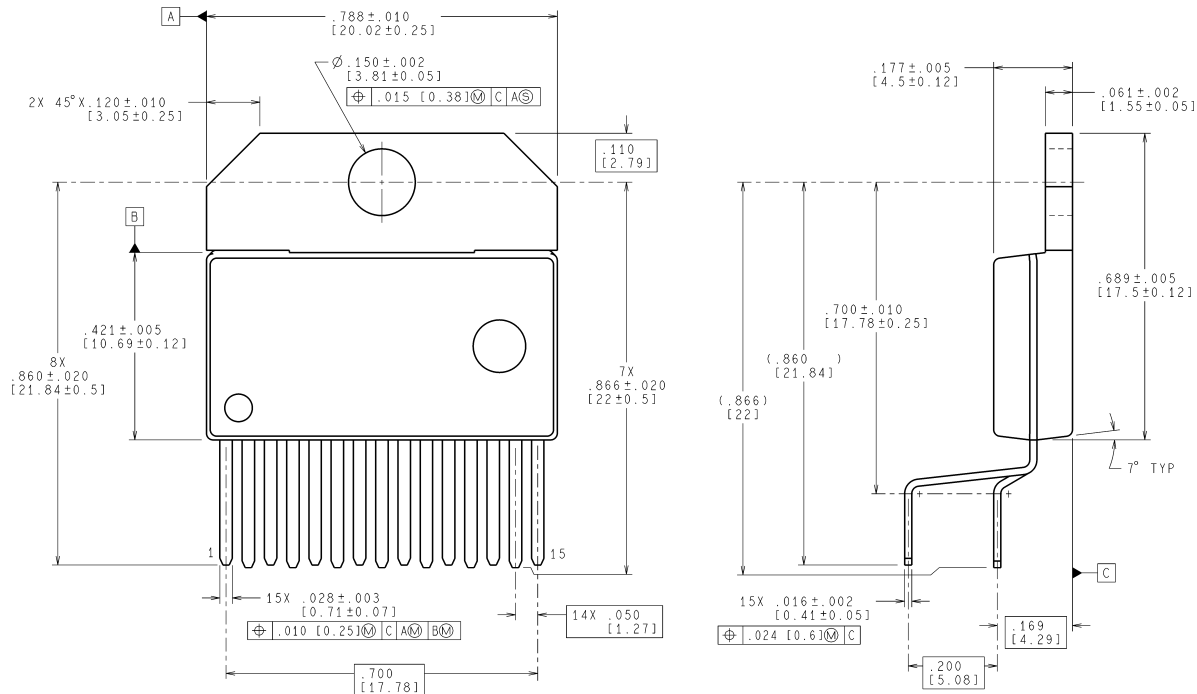

CONTROLLING DIMENSION IS INCH
VALUES IN [] ARE MILLIMETERS

TA15A (Rev B)

Non-Isolated TO-220 15-Lead Package
Order Number LM4702T(B&C)
NS Package Number TA15A

National does not assume any responsibility for use of any circuitry described, no circuit patent licenses are implied and National reserves the right at any time without notice to change said circuitry and specifications.

For the most current product information visit us at www.national.com.

LIFE SUPPORT POLICY

NATIONAL'S PRODUCTS ARE NOT AUTHORIZED FOR USE AS CRITICAL COMPONENTS IN LIFE SUPPORT DEVICES OR SYSTEMS WITHOUT THE EXPRESS WRITTEN APPROVAL OF THE PRESIDENT AND GENERAL COUNSEL OF NATIONAL SEMICONDUCTOR CORPORATION. As used herein:

1. Life support devices or systems are devices or systems which, (a) are intended for surgical implant into the body, or (b) support or sustain life, and whose failure to perform when properly used in accordance with instructions for use provided in the labeling, can be reasonably expected to result in a significant injury to the user.
2. A critical component is any component of a life support device or system whose failure to perform can be reasonably expected to cause the failure of the life support device or system, or to affect its safety or effectiveness.

BANNED SUBSTANCE COMPLIANCE

National Semiconductor manufactures products and uses packing materials that meet the provisions of the Customer Products Stewardship Specification (CSP-9-111C2) and the Banned Substances and Materials of Interest Specification (CSP-9-111S2) and contain no "Banned Substances" as defined in CSP-9-111S2.

Leadfree products are RoHS compliant.



National Semiconductor
Americas Customer Support Center
Email: new.feedback@nsc.com
Tel: 1-800-272-9959

National Semiconductor
Europe Customer Support Center
Fax: +49 (0) 180-530 85 86
Email: europe.support@nsc.com
Deutsch Tel: +49 (0) 69 9508 6208
English Tel: +44 (0) 870 24 0 2171
Français Tel: +33 (0) 1 41 91 8790

National Semiconductor
Asia Pacific Customer Support Center
Email: ap.support@nsc.com

National Semiconductor
Japan Customer Support Center
Fax: 81-3-5639-7507
Email: jpn.feedback@nsc.com
Tel: 81-3-5639-7560

