

VLX-53 and VLX-32 PHOTOVOLTAIC MODULES

TYPICAL ELECTRICAL CHARACTERISTICS⁽¹⁾

12 VOLT CONFIGURATION

	VLX-53	VLX-32
Typical Peak Power (Pp)	53W	32W
Voltage @ peak power (Vpp)	17.2	17.2V
Current @ peak power (Ipp)	3.08A	1.86A
Short-circuit current (Isc)	3.33A	2.01A
Open-circuit voltage (Voc)	21.3V	21.3V
Temperature coefficient of open-circuit voltage	-73 mV/°C	-73mV/°C
Temperature coefficient of short-circuit current	2.5 mA/°C	1.5 mA/°C
Approximate effect of temperature on power NOCT ⁽³⁾	-0.38%/°C 49°C	-0.38%/°C 49°C

NOTE: All Characteristics have tolerance of ±10%.

- These data represent the performance of typical modules as measured at their output terminals, and do not include the effect of such additional equipment as diodes and cables. The data are based on measurements made at Standard Test Conditions (STC) which are:
 - Illumination of 1 kW/m² (1 sun) at spectral distribution of AM 1.5
 - Cell temperature of 25°C or as otherwise specified (on curves).
- Electrical characteristics of modules wired in the nominal 6V configuration may be found by using the 6V scales on the I-V curves. For more exact values, divide the 12V voltage characteristics in the table by 2 and multiply the 12V current characteristics by 2. Power values are unchanged.
- Under nearly all climatic conditions, the solar cells in an operating module are hotter than the ambient temperature, a fact which must be considered when reading module data. Operating Cell Temperature is an indication of this temperature rise, and is defined under Standard Operating Conditions: ambient temperature of 20°C, solar irradiation of 0.8 kW/m², and average wind speed of 1 m/s.

VLX - 53 IV-CHARACTERISTICS

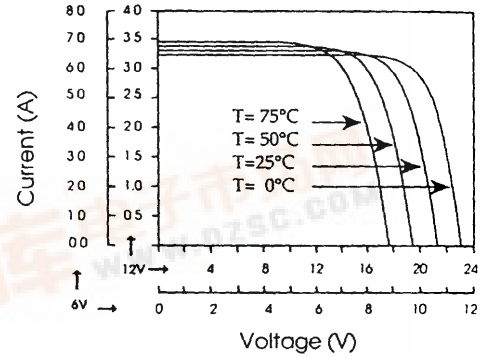

VLX - 32 IV-CHARACTERISTICS

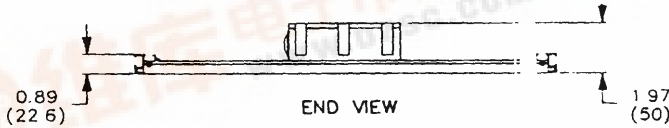
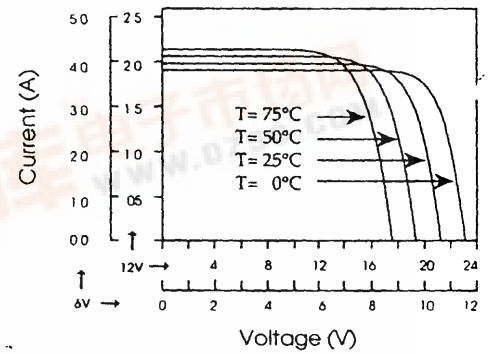

MECHANICAL CHARACTERISTICS

Weight VLX-53 12.Lbs. (5.5 kg)
VLX-32 7.7 lbs. (3.5 kgs)

DIMENSIONS:

Dimensions in brackets are in millimeters Unbracketed dimensions are in inches

PACKAGING

Two modules per box.
Can be shipped UPS.

DISTRIBUTED BY

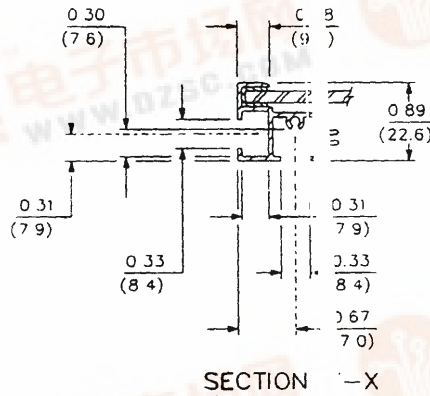

	DIM. A
VLX-32	23.28 (591)
VLX-53	36.88 (937)

