

OptoMOS®

AC/DC Solid State Switches

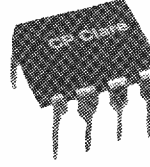

Engineering Specifications	LAA110	LAA120	LBA110	LBA120	LBB110	LBB120	LCC110	LCC120	OAA160
Output Characteristics									
Peak Blocking (V)	350	250	350	250	350	250	350	250	250
Continuous Rated Load (mA)*	120	170	120	170	120	170	120	170	50
Peak Load/10msec (mA)	350	400	350	400	350	400	350	350	100
On Resistance (Ohms)									
Typical	23	12	23	16	23	16	23	16	50
Maximum	35	20	35	20	35	20	35	20	100
Switching Time (Max)									
I _{CONTROL} (mA)	5	5	5	5	5	5	8	10	10
T _{ON} (msec)	3	5	3	5	3	5	4	5	.125
T _{OFF} (msec)	3	5	3	5	3	5	4	5	.125
Off State Leakage (Max) at Full Rated Voltage (µA)	1	1	1	1	1	1	1	1	.025
Typical Capacitance at 0 Volts f = 1MHz (pF)	25	50	25	50	25	50	25	50	5

*I_{LOAD} derates to 80% if both poles are operated simultaneously.

Input Characteristics									
Control Current (mA)*									
Minimum	5	5	5	5	5	5	8	10	10
Maximum	100	100	100	100	100	100	100	100	100
Voltage Drop (V)									
Minimum	0.9	0.9	0.9	0.9	0.9	0.9	0.9	0.9	0.9
Maximum	1.4	1.4	1.4	1.4	1.4	1.4	1.4	1.4	1.4
Reverse Voltage (max V)	5	5	5	5	5	5	5	5	5
Reverse Leakage (max µA)	10	10	10	10	10	10	10	10	10
Input/Output (Capacitance, pF)	3	3	3	3	3	3	3	3	3

*I_{CONTROL} represents the forward LED current used to activate the switch.

Features:

- Rated to 350V AC or DC
- Load current to 170 mA
- Optical isolation to 3750V
- No EMI/RFI generation
- 100% dv/dt immunity
- Machine insertable/wave solderable
- SMD versions available
- UL recognized
- No minimum load voltage or current

Absolute Maximum Ratings

Parameter	Min	Max	Units
Input/Output Isolation	2500	—	V _{RMS}
Optional "E" Suffix	3750	—	V _{RMS}
Operating Temperature	-40	85	°C
Storage Temperature	-40	125	°C
Soldering Temperature (10 seconds on leads)	—	260	°C

When ordering CP Clare solid state switches, a suffix may be added to the part number to specify the following options:

Suffix	Option
E	3,750 Isolation Voltage
S	Gull-Wing Package*
T/R	Tape and Reel Package*
L	Current Limiting Version

Note: Special part numbers are available on an application/request basis.



OptoMOS[®]

AC/DC Operating Specifications

Performance

Load vs. Temperature

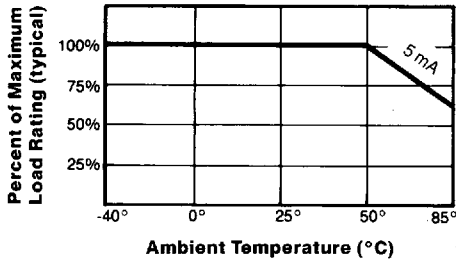

On Resistance vs. Temperature

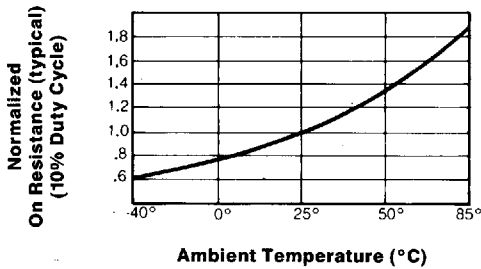

Energy Rating

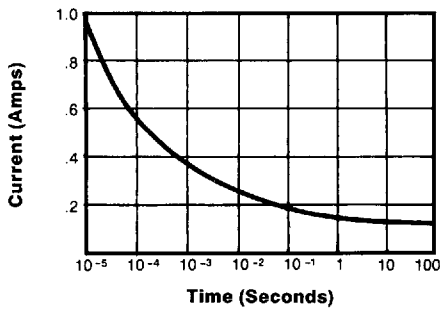

Switching Time vs. Temperature (LCC Series)

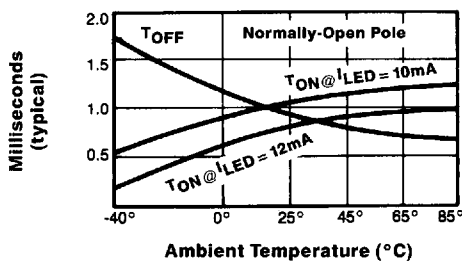

Switching Time vs. Temperature (LCC Series)

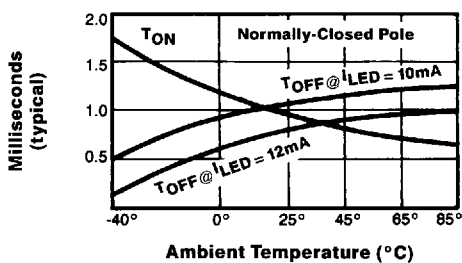

Switching Time vs. Temperature (LBA Series)

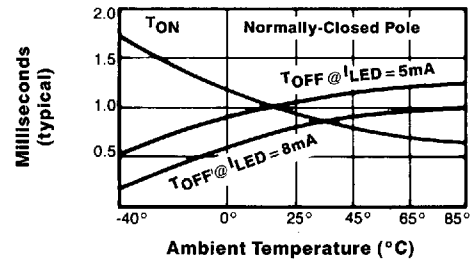

Switching Time vs. Temperature (LBA Series)

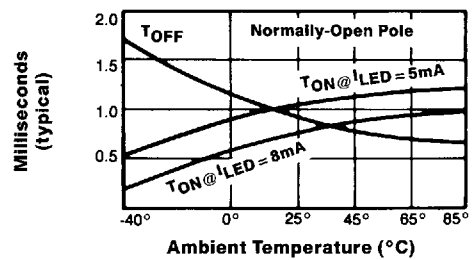

Equivalent Circuit

LAA/OAA

LAA/OAA 110/120 PIN
 CONNECTIONS:
 1, 2 Control, Pole 1
 3, 4 Control, Pole 2
 5, 6 Normally-Open Pole 2
 7, 8 Normally-Open Pole 1

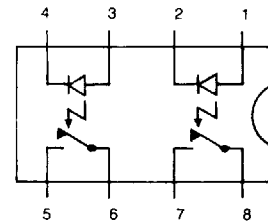

LBA

LBA 110/120 PIN
 CONNECTIONS:
 1, 2 Normally-Closed Control
 3, 4 Normally-Open Control
 5, 6 Normally-Open Pole
 7, 8 Normally-Closed Pole

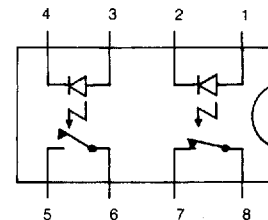

LBB

LBB 110/120 PIN
 CONNECTIONS:
 1, 2 Control, Pole 1
 3, 4 Control, Pole 2
 5, 6 Normally-Closed Pole 2
 7, 8 Normally-Closed Pole 1

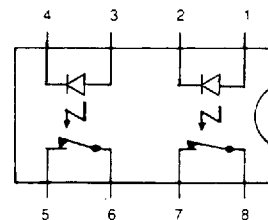

LCC

LCC 110/120 PIN
 CONNECTIONS:
 1 N/C
 2 + Control
 3 - Control
 4 Do Not Use
 5, 6 Normally-Open Pole
 7, 8 Normally-Closed Pole

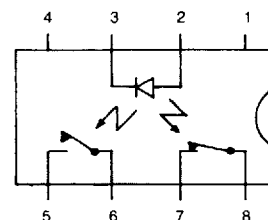

6 Pin Through Hole (Standard)

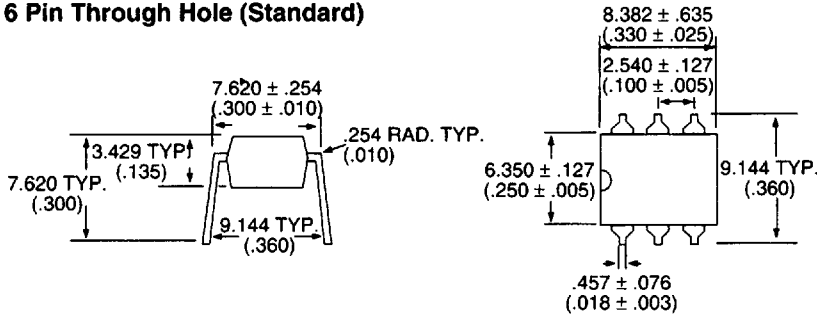

6 Pin PC Board Pattern (Bottom View)

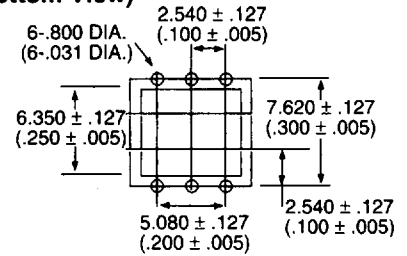

6 Pin Surface Mount ("S" Suffix)

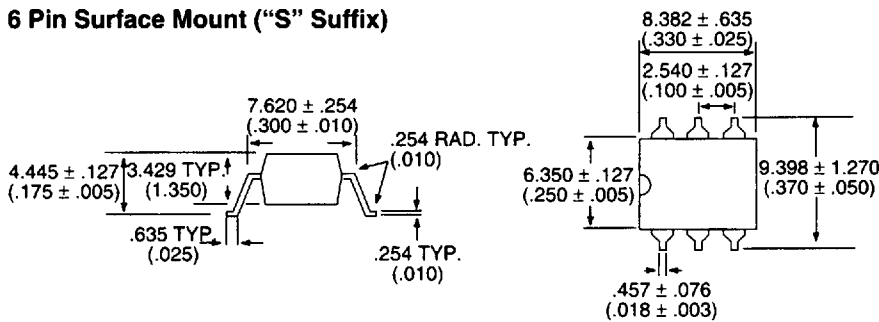

6 Pin Mounting Pad (Top View)

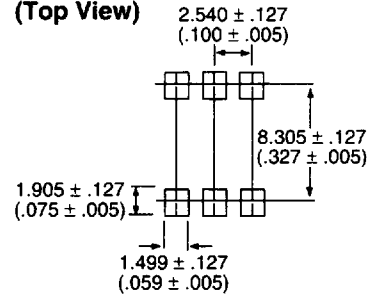

8 Pin Through Hole (Standard)

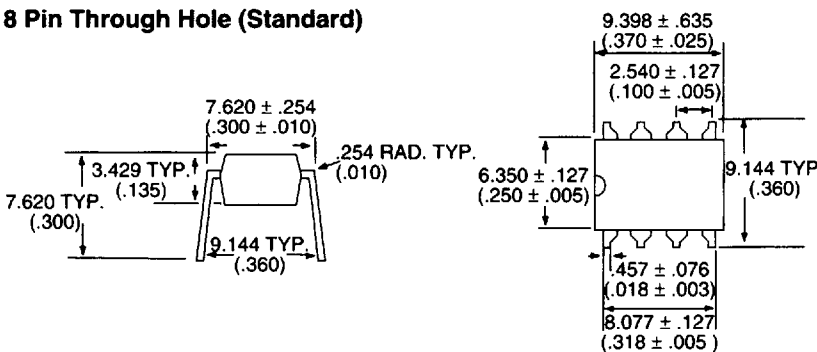

8 Pin PC Board Pattern (Bottom View)

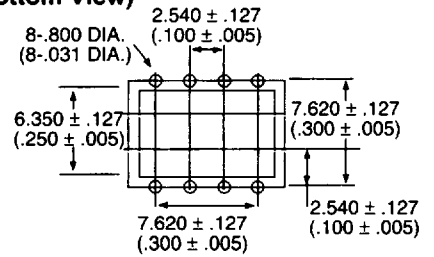

8 Pin Surface Mount ("S" Suffix)

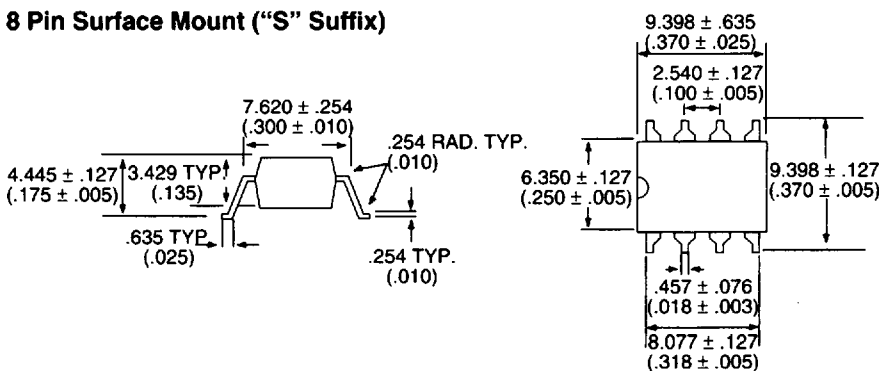

8 Pin Mounting Pad (Top View)

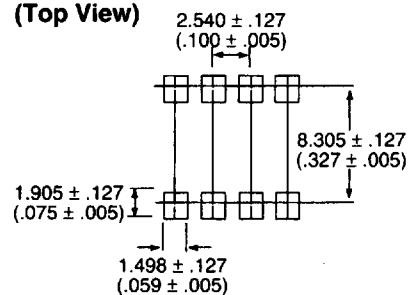

DIMENSIONS
mm
(Inches)

8 Pin Flatpack ("P" Suffix)

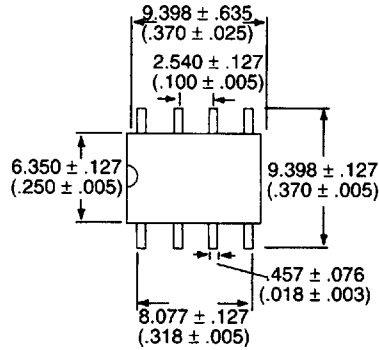
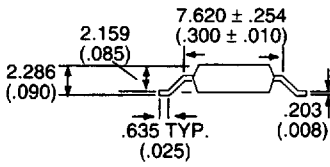

8 Pin Flatpack Mounting Pad (Top View)

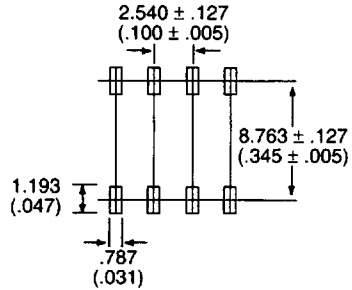

16 Pin SOIC ("P" Suffix)

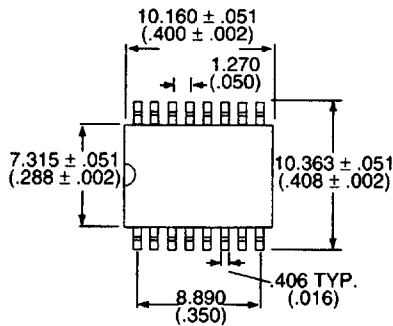
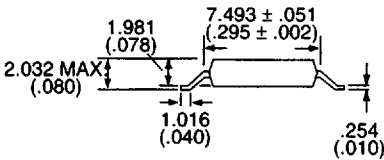

16 Pin SOIC Mounting Pad (Top View)

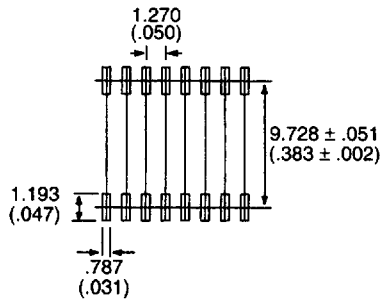

16 Pin Through Hole (Standard)

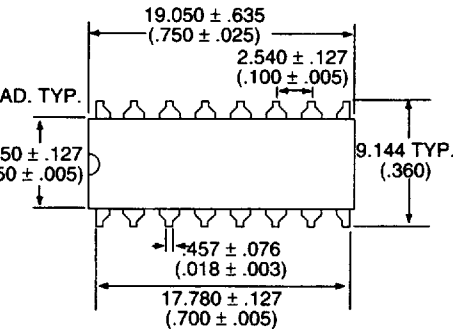
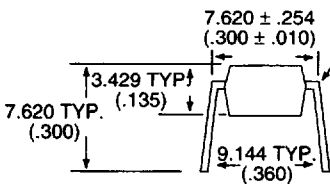

16 Pin PC Board Pattern (Bottom View)

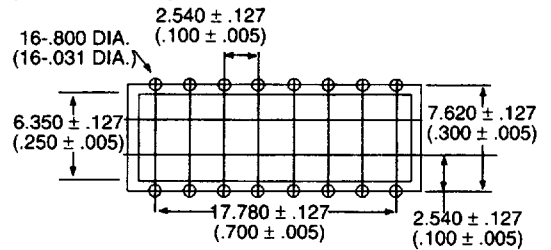

8 Pin SIP

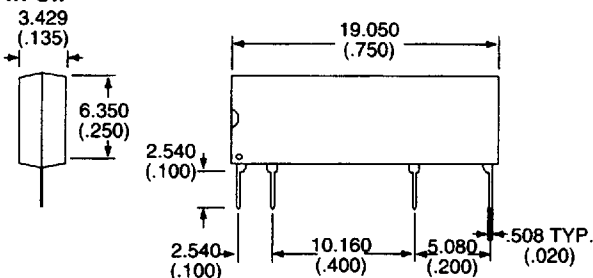

DIMENSIONS
mm
(Inches)

16 Pin DIP

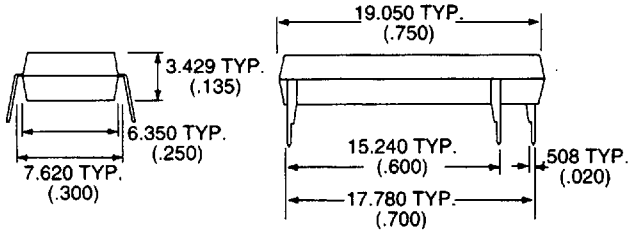

Thermal Clip

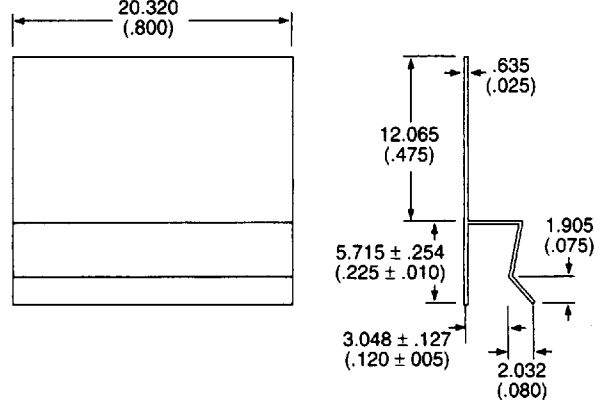

OptoFILM® 10A Series, Pins

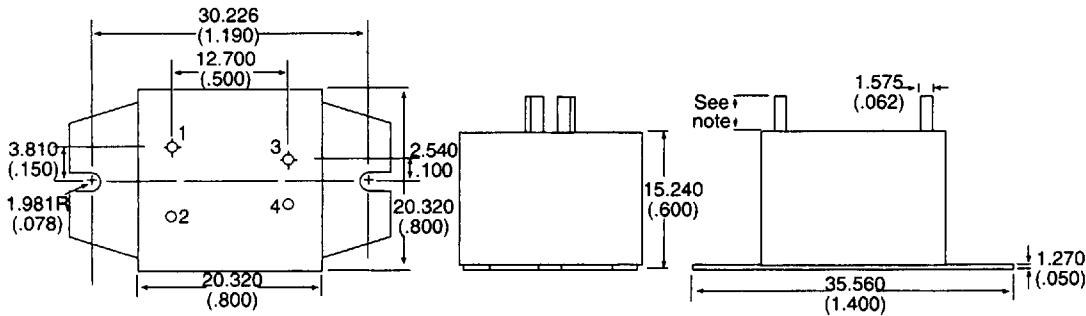

Note: Specify "-1" (0.300" pins)
 Specify "-3" (0.175" pins)

OptoFILM® 10A Series, Quick Connect

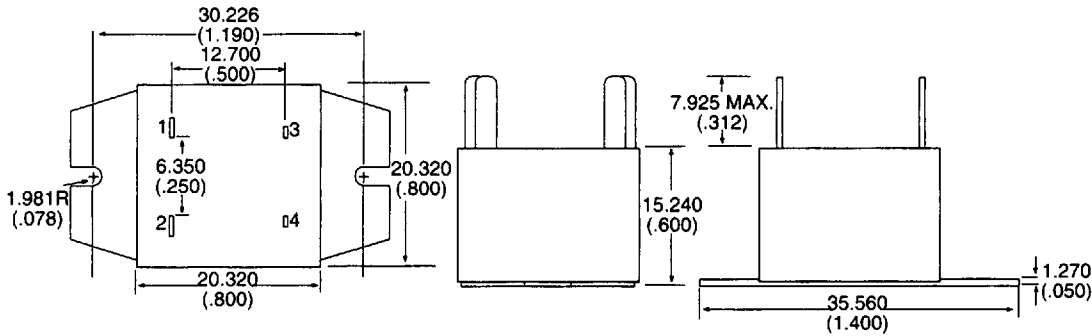

Tape and Reel Packaging for 6 Pin Surface Mount Package

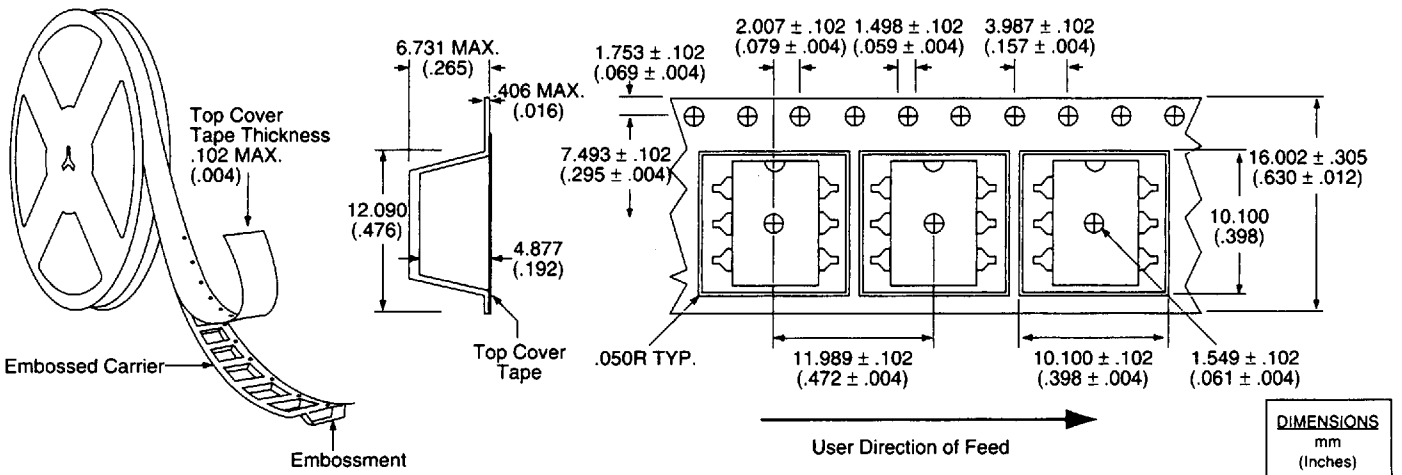

DIMENSIONS
mm
(Inches)

Tape and Reel Packaging for 8 Pin Surface Mount Package

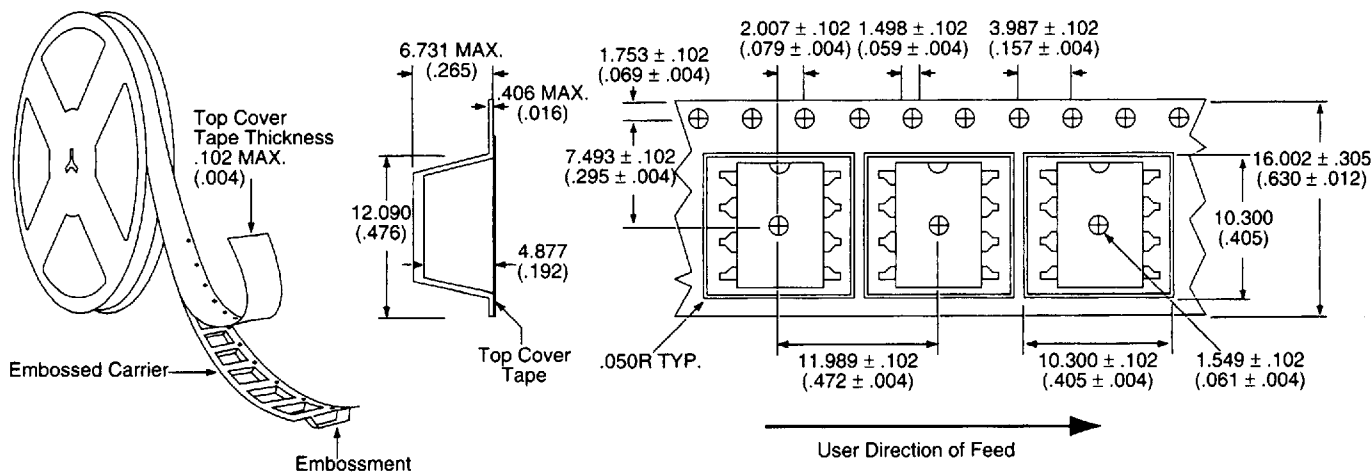

Tape and Reel Packaging for 8 Pin Flatpack Package

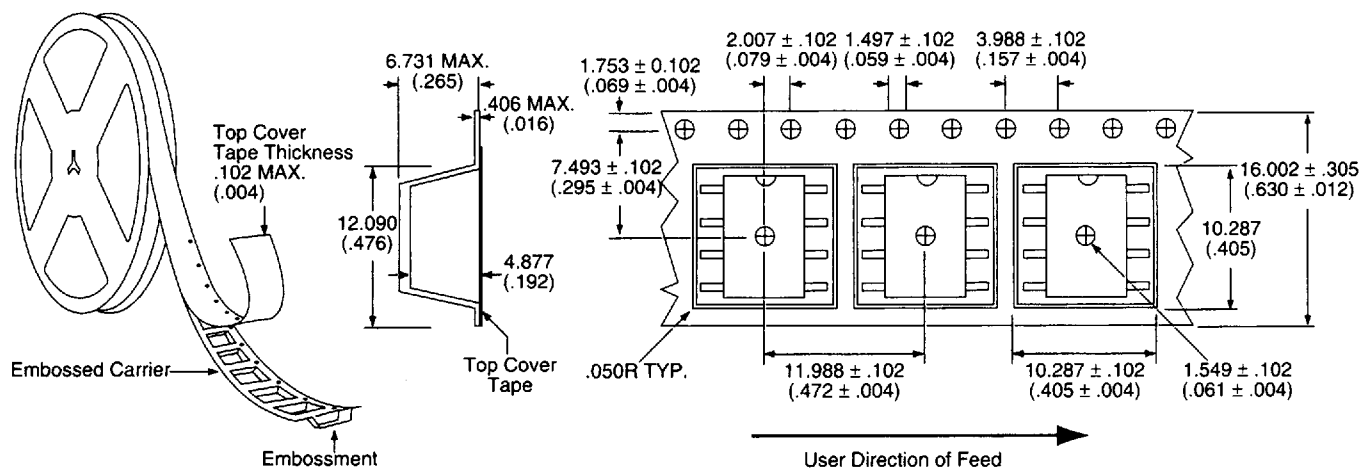

Tape and Reel Packaging for 16 Pin SOIC Package

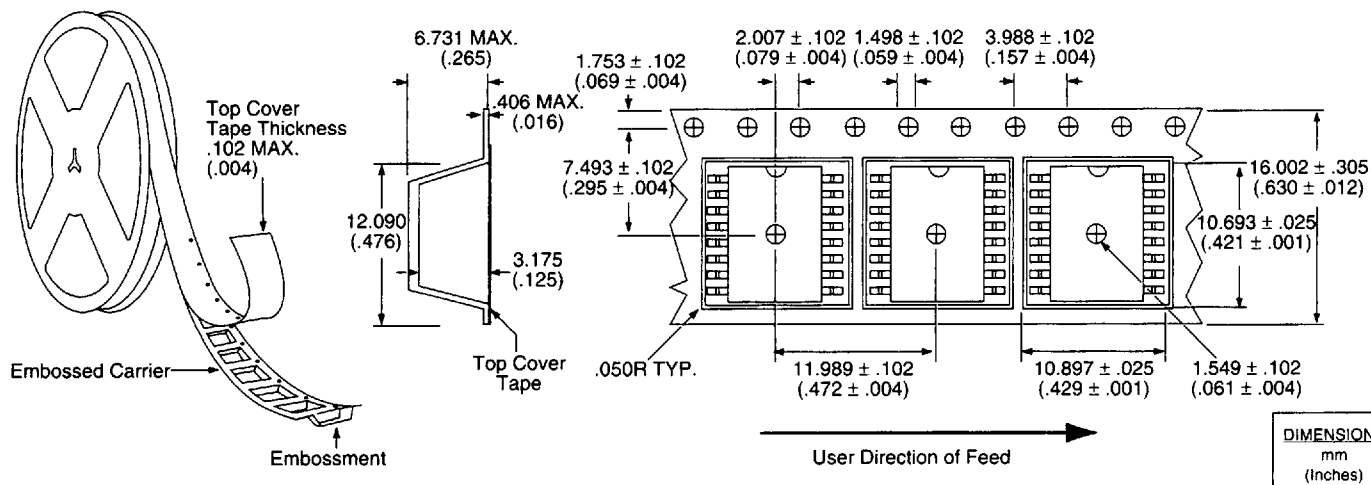

DIMENSIONS
mm
(Inches)