

RENESAS

R2J20601NP

Driver – MOS FET Integrated SiP (DrMOS)

REJ03G0237-0500

Rev.5.00

Apr 10, 2006

Description

The R2J20601NP multi-chip module incorporates a high-side MOS FET, low-side MOS FET, and MOS-FET driver in a single QFN package. The on and off timing of the power MOS FET is optimized by the built-in driver, making this device suitable for large-current buck converters. The chip also incorporates a high-side bootstrap Schottky barrier diode (SBD), eliminating the need for an external SBD for this purpose.

Integrating a driver and both high-side and low-side power MOS FETs, the new device is also compliant with the package standard “Driver – MOS FET integrated SiP (DrMOS)” proposed by Intel Corporation.

Features

- Built-in power MOS FET suitable for applications with 12 V input and low output voltage
- Built-in driver circuit which matches the power MOS FET
- Built-in tri-state input function which can support a number of PWM controllers
- VIN operating-voltage range: 16 V max
- High-frequency operation (above 1 MHz) possible
- Large average output current (35 A)
- Achieve low power dissipation (About 5.6 W at 1 MHz, 25 A)
- Controllable driver: Remote on/off
- Built-in Schottky diode for bootstrapping
- Low-side drive voltage can be independently set
- Small package: QFN56 (8 mm × 8 mm × 0.8 mm)

Outline

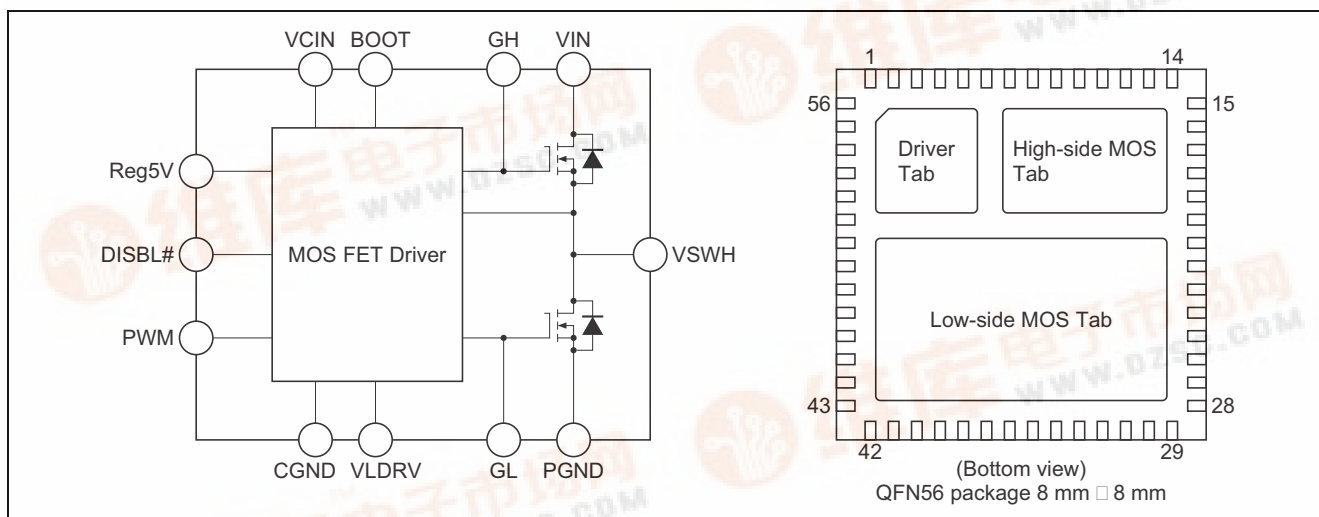

R2J20601NP

Block Diagram

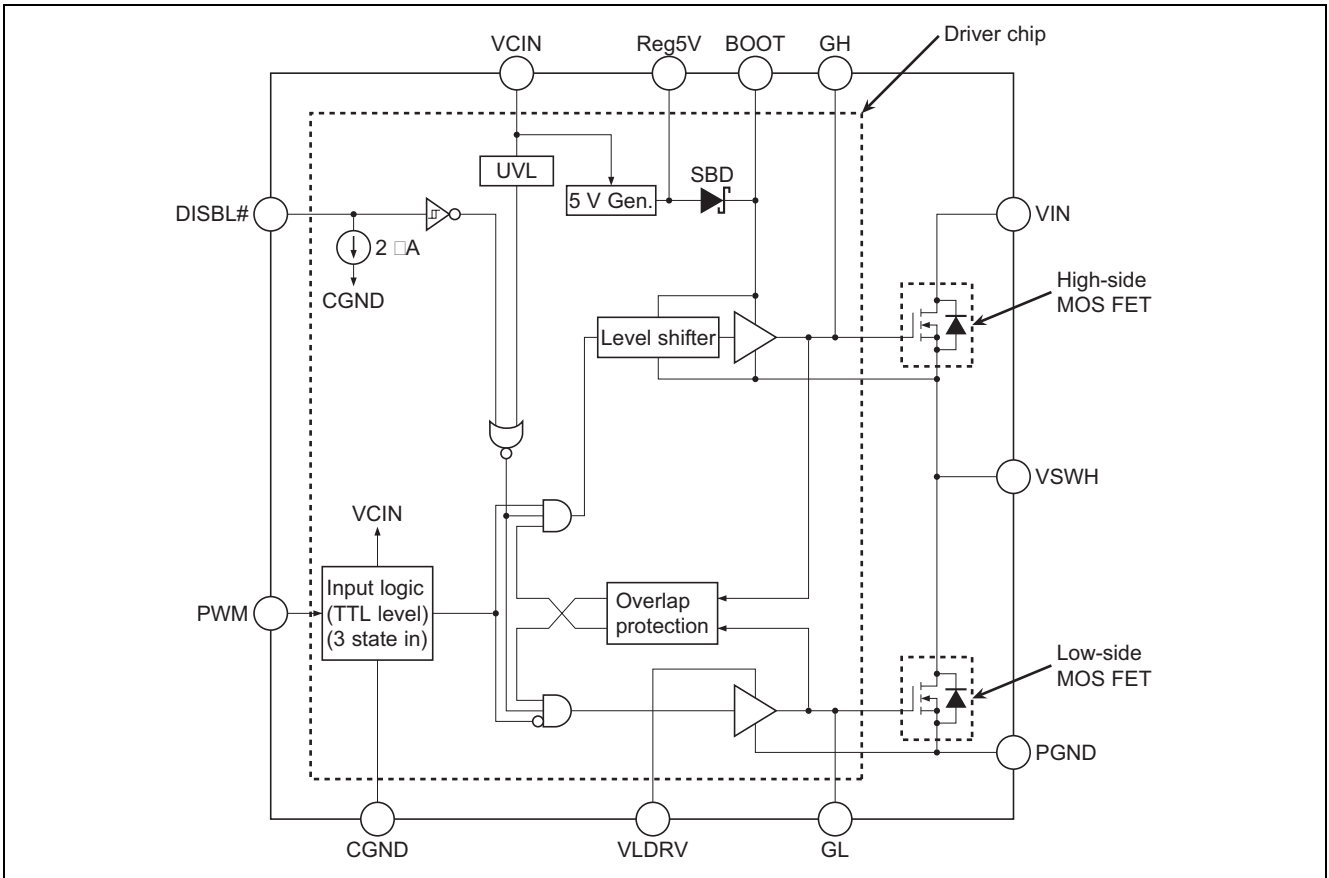

Notes: 1. Truth table for the DISBL# pin.

DISBL# Input	Driver Chip Status
"L"	Shutdown (GL, GH = "L")
"Open"	Shutdown (GL, GH = "L")
"H"	Enable (GL, GH = "Active")

2. Output signal from the UVL block

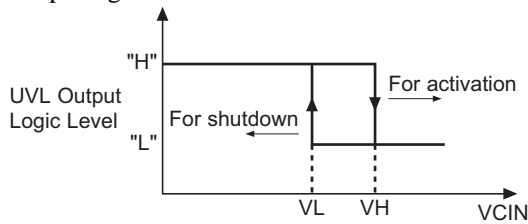

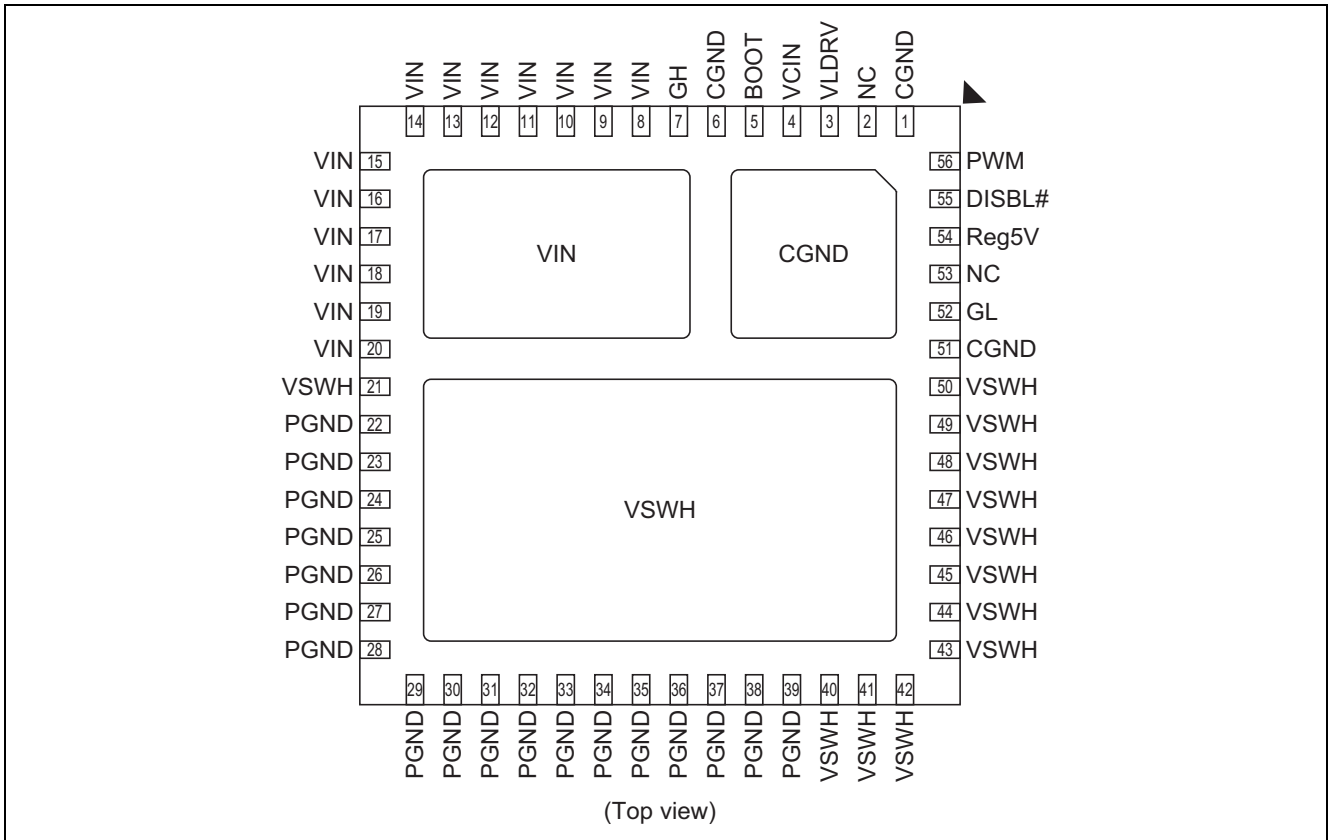
R2J20601NP**Pin Arrangement****Pin Description**

Pin Name	Pin No.	Description	Remarks
CGND	1, 6, 51, Tab	Control signal ground	Should be connected to PGND externally
NC	2, 53	No connect	
VLDRV	3	Low side gate supply voltage	For 5 V to 12 V gate drive voltage for Low side gate driver
VCIN	4	Control input voltage (+12 V input)	Driver Vcc input
BOOT	5	Bootstrap voltage pin	To be supplied +5 V through internal SBD
GH	7	High side gate signal	Pin for Monitor
VIN	8 to 20, Tab	Input voltage	
VSWH	21, 40 to 50, Tab	Phase output/Switch output	
PGND	22 to 39	Power ground	
GL	52	Low side gate signal	Pin for Monitor
Reg5V	54	+5 V logic power supply output	
DISBL#	55	Signal disable	Disabled when DISBL# is "L"
PWM	56	PWM drive logic input	

R2J20601NP**Absolute Maximum Ratings**

(Ta = 25°C)

Item	Symbol	Rating	Units	Note
Power dissipation	Pt(25)	25	W	1
	Pt(110)	8	W	1
Average output current	Iout	35	A	
Input voltage	VIN (DC)	-0.3 to +16	V	2
	VIN (AC)	20		2, 6
Supply voltage	VCIN (DC)	-0.3 to +16	V	2
	VCIN (AC)	20		2, 6
Low side driver voltage	VLDRV (DC)	-0.3 to +16	V	2
	VLDRV (AC)	20		2, 6
Switch node voltage	VSWH (DC)	16	V	2
	VSWH (AC)	20		2, 6
BOOT voltage	VBOOT	22	V	2
DISBL# voltage	Vdisble	-0.3 to VCIN	V	2
PWM voltage	Vpwm	-0.3 to +5.3	V	2, 4
		-0.3 to +0.3	V	2, 5
Reg5V current	Ireg5V	-10 to +0.1	mA	3
Operating junction temperature	Tj-opr	-40 to +150	°C	
Storage temperature	Tstg	-55 to +150	°C	

Notes: 1. Pt(25) represents a PCB temperature of 25°C, and Pt(100) represents 100°C.

- Rated voltages are relative to voltages on the CGND and PGND pins.
- For rated current, (+) indicates inflow to the chip and (-) indicates outflow.
- This rating is when UVL (Under Voltage Lock out) is ineffective (normal operation mode).
- This rating is when UVL (Under Voltage Lock out) is effective (lock out mode).
- The specification values indicated "AC" are limited within 100 ns.

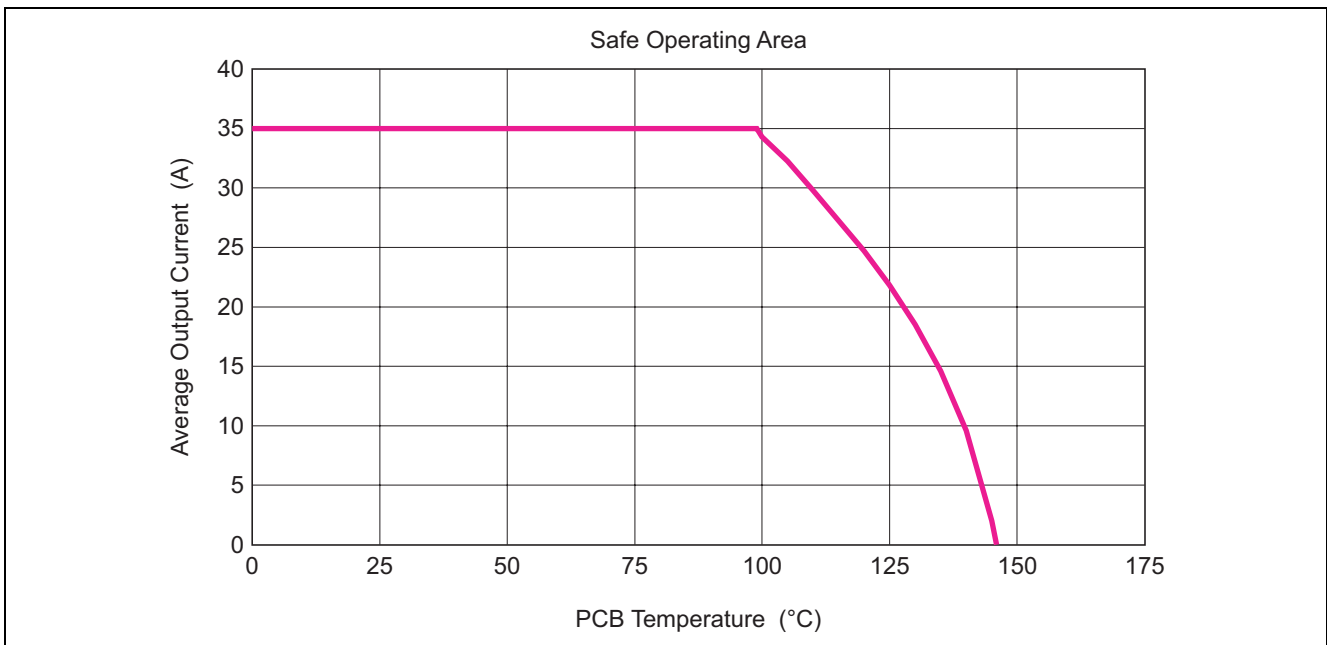

R2J20601NP**Electrical Characteristics**

(Ta = 25°C, VCIN = 12 V, VLDRV = 5 V, VSWH = 0 V, unless otherwise specified)

Item		Symbol	Min	Typ	Max	Units	Test Conditions
Supply	VCIN start threshold	V _H	8.1	9.0	9.9	V	
	VCIN shutdown threshold	V _L	6.5	7.2	7.9	V	
	UVLO hysteresis	dUVL	—	1.8 * ¹	—	V	V _H - V _L
	VCIN bias current	I _{CIN}	10.5	14.0	18.5	mA	f _{PWM} = 1 MHz, t _{on-PWM} = 125 ns
	VLDRV bias current	I _{LDRV}	31.5	40.7	46.5	mA	f _{PWM} = 1 MHz, t _{on-PWM} = 125 ns
PWM Input	PWM rising threshold	V _{H-PWM}	3.5	3.8	4.1	V	
	PWM falling threshold	V _{L-PWM}	0.9	1.2	1.5	V	
	PWM input resistance	R _{IN-PWM}	30	50	70	kΩ	PWM = 1 V
	Tri-state shutdown window	V _{IN-SD}	V _{L-PWM}	—	V _{H-PWM}	V	
	Shutdown hold-off time	t _{HOLD-OFF}	—	240 * ¹	—	ns	
5V Regulator	Output voltage	V _{reg}	4.75	5.0	5.25	V	
	Line regulation	V _{reg-line}	-10	0	10	mV	VCIN = 12 V to 16 V
	Load regulation	V _{reg-load}	-10	0	10	mV	I _{reg} = 0 to 10 mA
DISBL# Input	Disable threshold	V _{DISBL}	0.9	1.2	1.5	V	
	Enable threshold	V _{ENBL}	1.9	2.4	2.9	V	
	Input current	I _{DISBL}	0.5	2.0	5.0	μA	DISBL# = 1 V

Note: 1. Reference values for design. Not 100% tested in production.

R2J20601NP

Typical Application

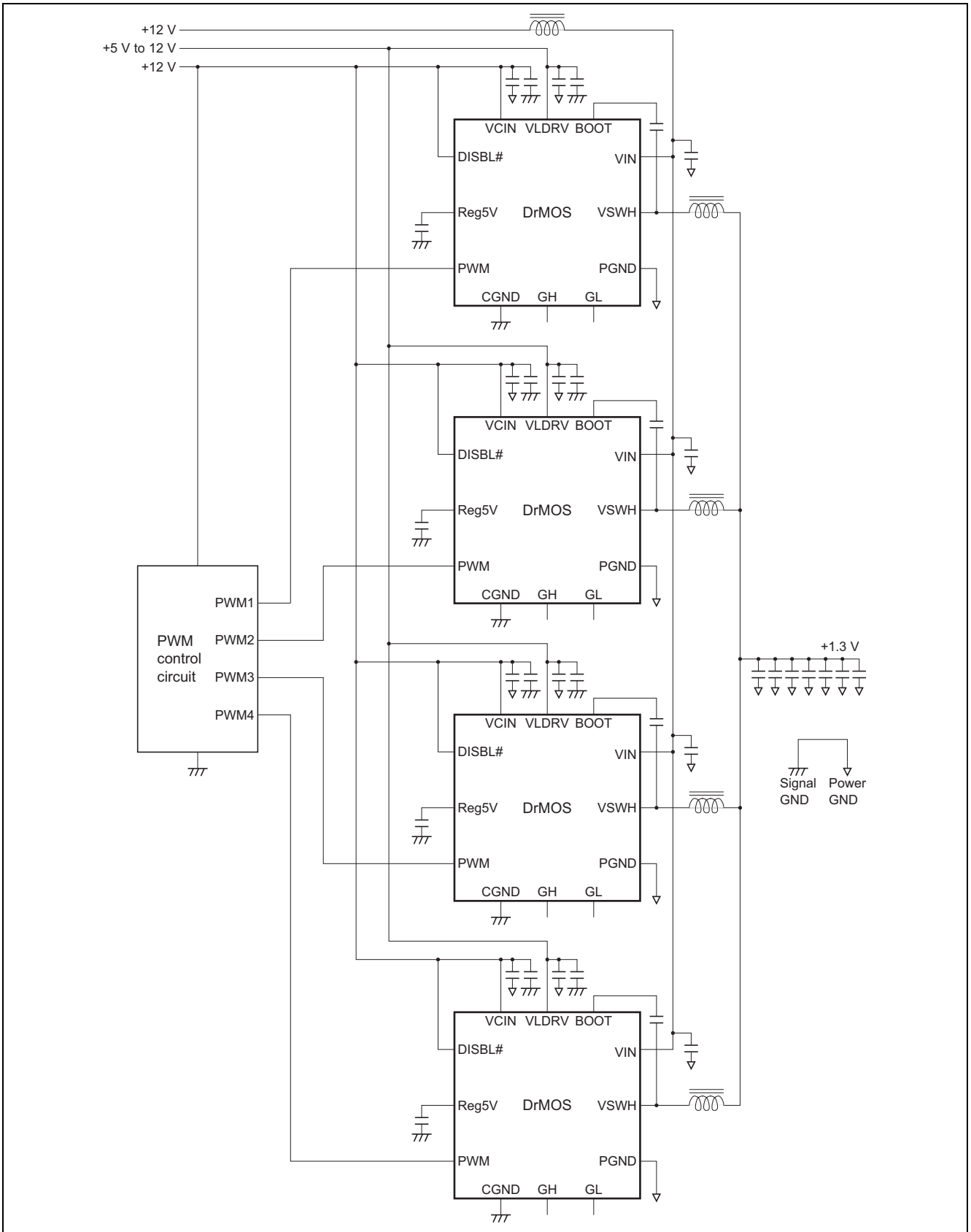

R2J20601NP

Test Circuit

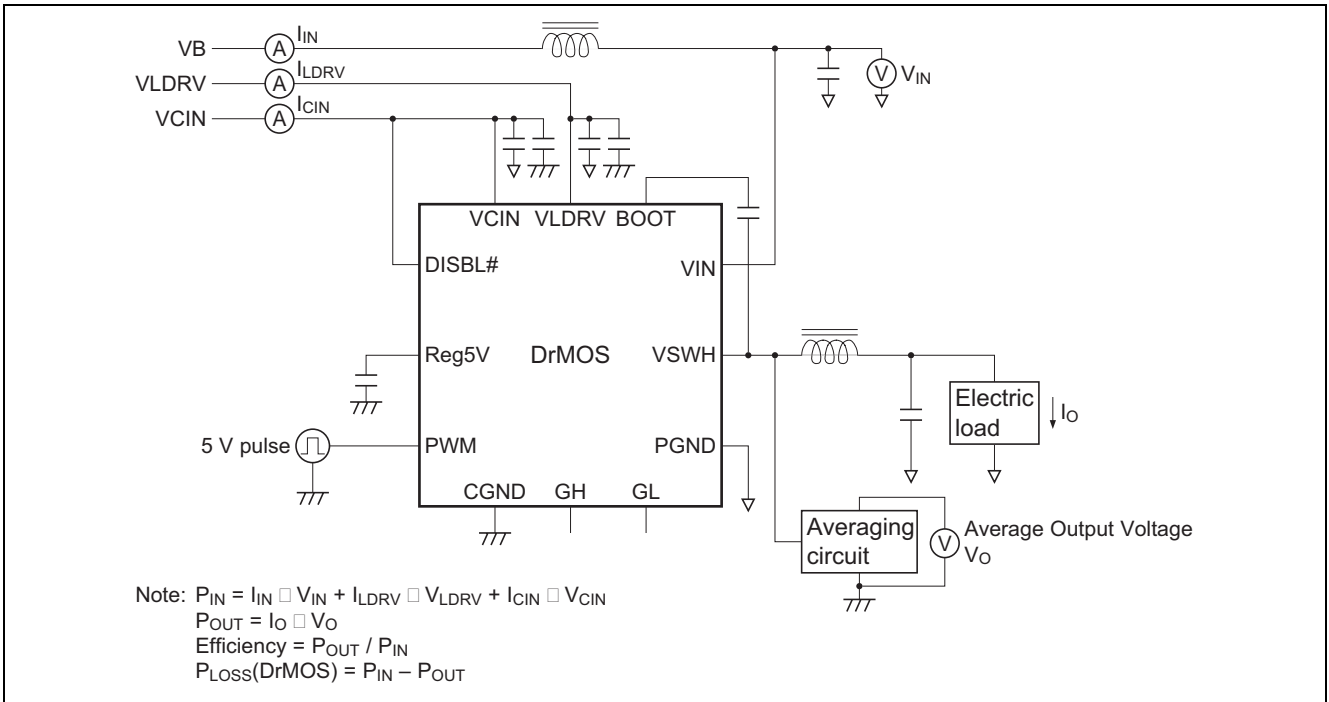

R2J20601NP

Typical Data

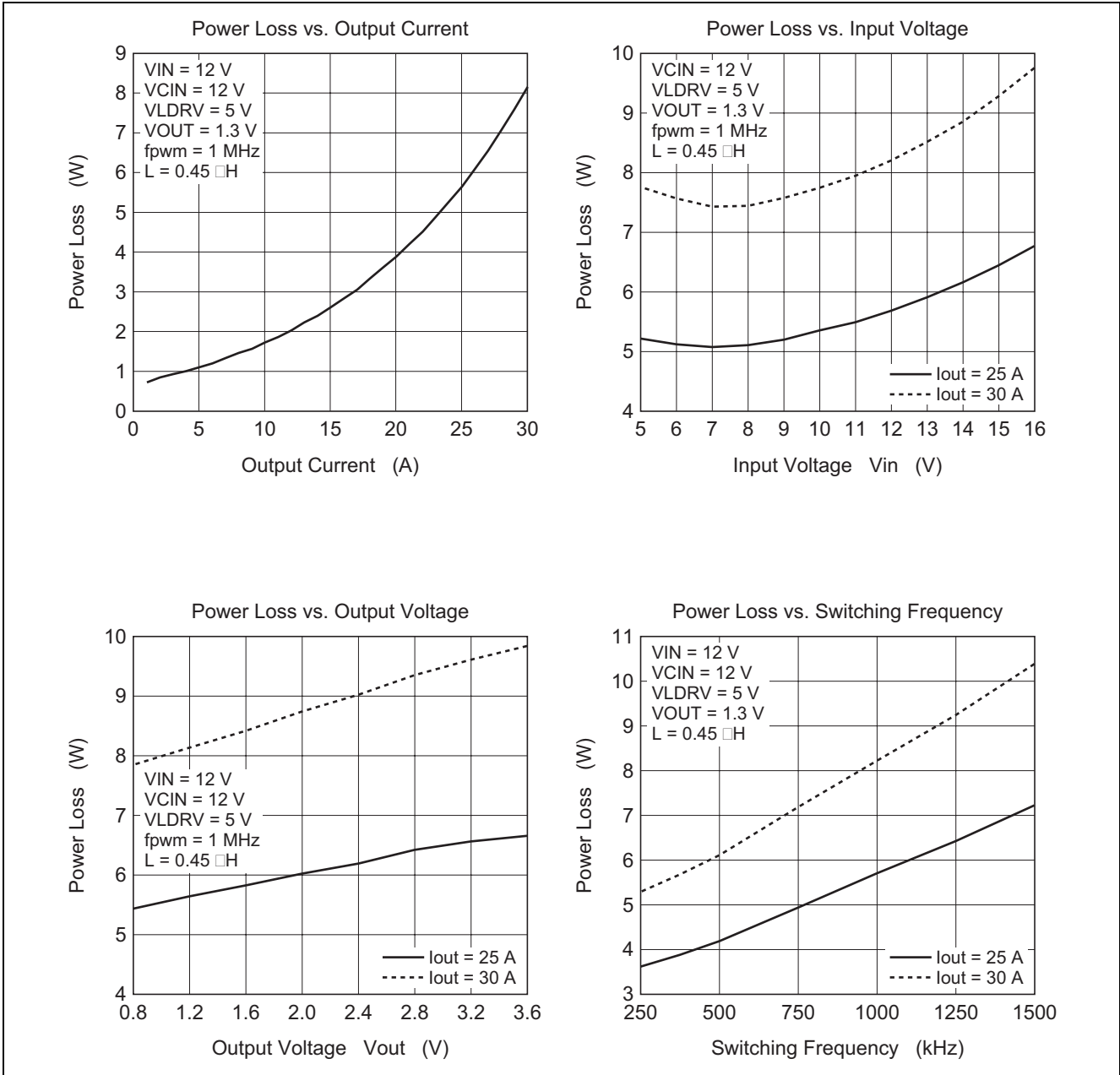

R2J20601NP

Typical Data (cont.)

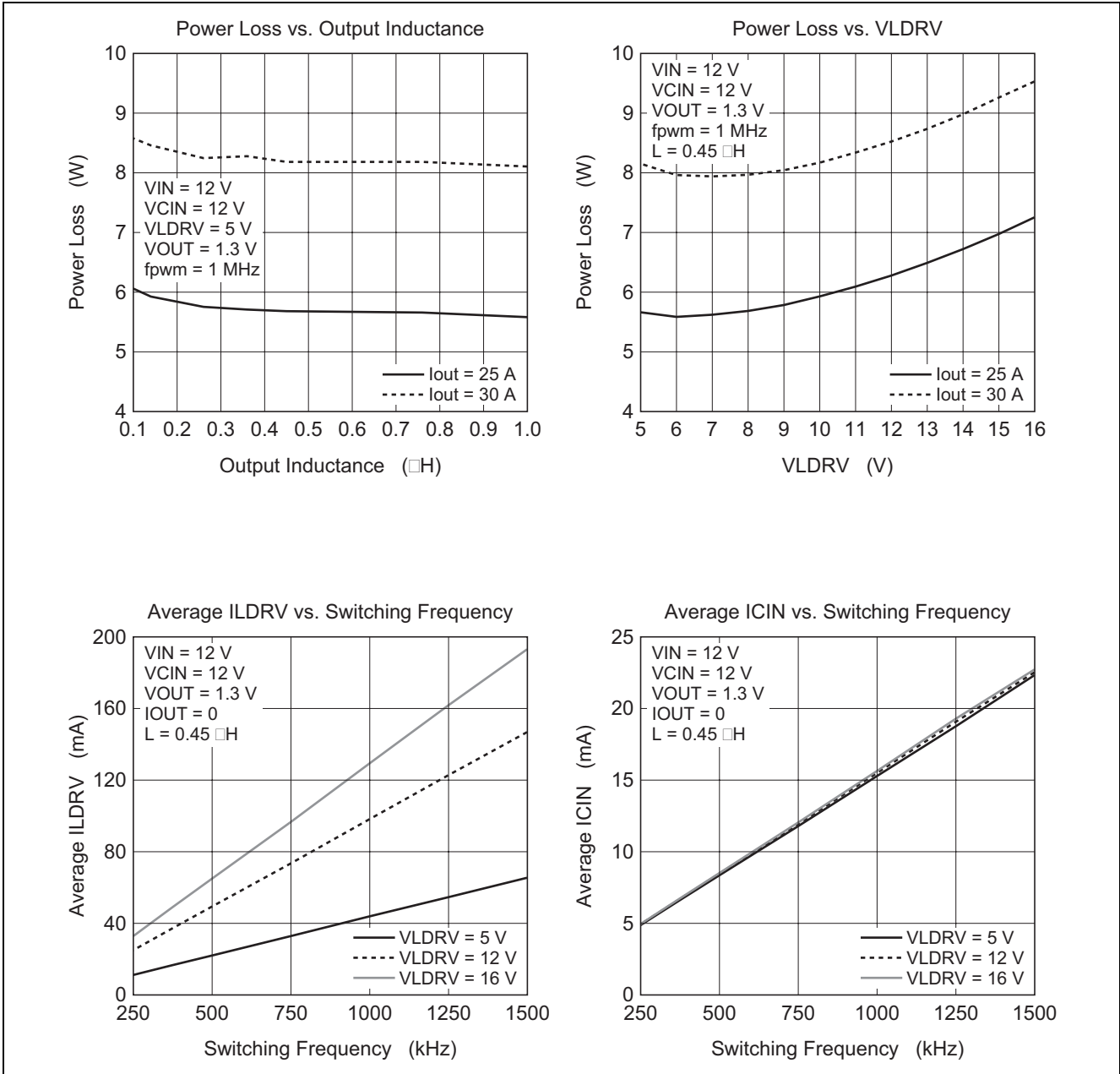

R2J20601NP

Description of Operation

The DrMOS multi-chip module incorporates a high-side MOS FET, low-side MOS FET, and MOS-FET driver in a single QFN package. Since the parasitic inductance between each chip is extremely small, the module is highly suitable for use in buck converters to be operated at high frequencies. The control timing between the high-side MOS FET, low-side MOS FET, and driver is optimized so that high efficiency can be obtained at low output-voltage.

Driver

The driver has two types of power-supply voltage input pin, VCIN and VLDRV. VCIN supplies the operating voltage to the internal logic circuit. The low-side driving voltage is applied to VLDRV, so setting of the gate-driving voltage for the low-side MOS FET is independent of the voltage on VCIN. The VLDRV setting voltage is from 5 V to 16 V.

The VCIN pin is connected to the UVL (under-voltage lockout) module, so that the driver is disabled as long as VCIN is 9 V or less. On cancellation of UVL, the driver remains enabled until the UVL input is driven to 7.2 V or less. The signal on pin DISBL# also enables or disables the circuit. When UVL disables the circuit, the built-in 5 V regulator does not operate, but when the signal on DISBL# disables the circuit, only output-pulse generation is terminated, and the 5 V regulator is not disabled.

VCIN	VLDRV	DISBL#	Reg5V	Driver state
L	>5 V	*	0	Disable (GL, GH = L)
H	>5 V	L	5 V	Disable (GL, GH = L)
H	>5 V	H	5 V	Active
H	>5 V	Open	5 V	Disable (GL, GH = L)

Voltages from -0.3 V to VCIN can be applied to the DISBL# pin, so on/off control by a logic IC or the use of a resistor, etc., to pull the DISBL# line up to VCIN are both possible.

The built-in 5 V regulator is a series regulator with temperature compensation. The voltage output by this regulator determines the operating voltage of the internal logic and gate-voltage swing for the high-side MOS FET. A ceramic capacitor with a value of $0.1 \mu\text{F}$ or more must be connected between the CGND plane and the Reg5V pin.

The PWM pin is the signal input pin for the driver chip. The input-voltage range is -0.3 V to (Reg5V + 3 V). When the PWM input is high, the gate of the high-side MOS FET (GH) is high and the gate of the low-side MOS FET (GL) is low.

PWM	GH	GL
L	L	H
H	H	L

R2J20601NP

The PWM input is TTL level and has hysteresis. When the PWM input signal is abnormal, e.g., when the signal route from the control IC is abnormal, the tri-state function turns off the high- and low-side MOS FETs. This function operates when the PWM input signal stays in the input hysteresis window for 240 ns (typ.). After the tri-state mode has been entered and GH and GL have become low, a PWM input voltage of 3.8 V or more is required to make the circuit return to normal operation.

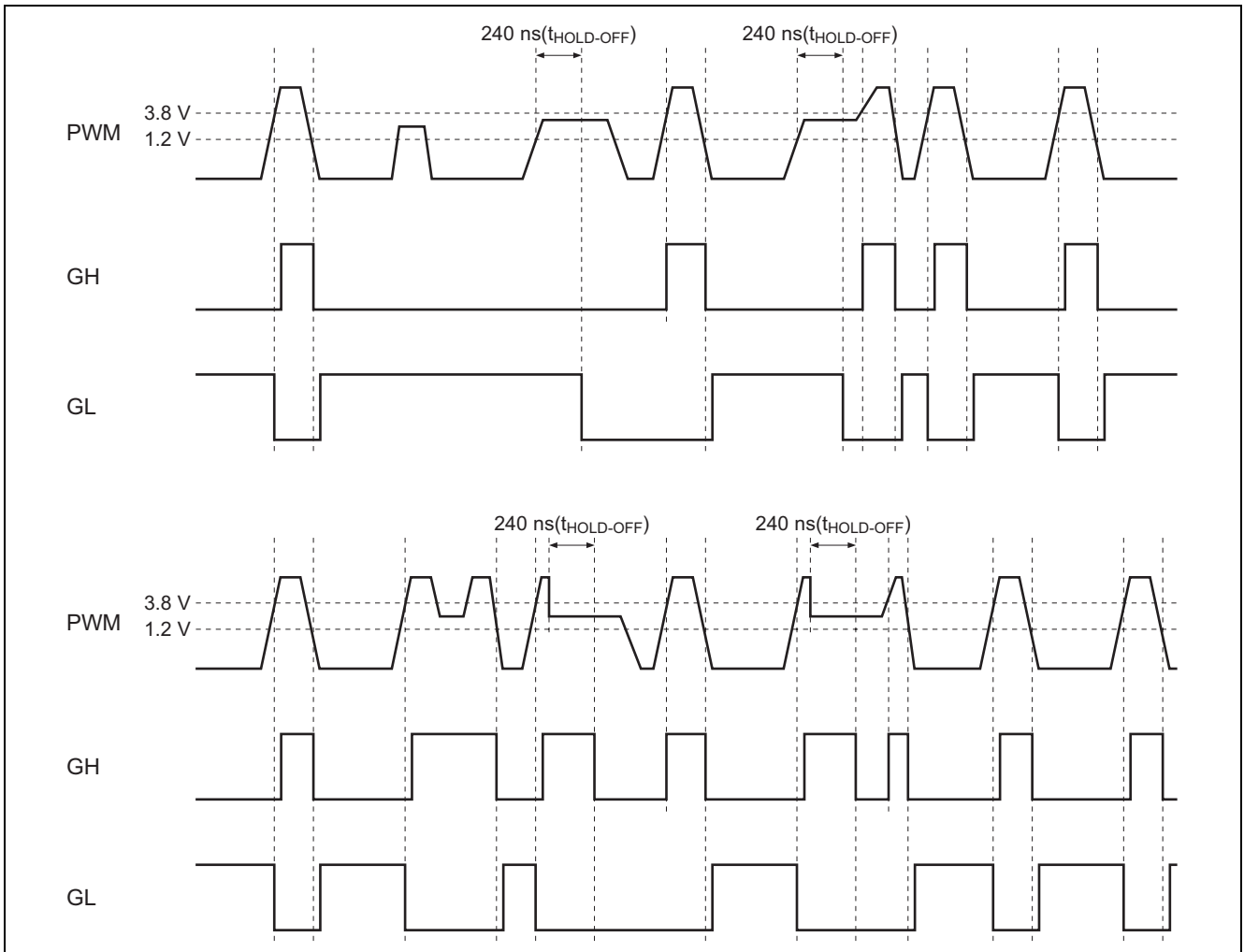

Figure 1

R2J20601NP

The equivalent circuit for the PWM-pin input is shown in the next figure. M1 is in the ON state during normal operation; after the PWM input signal has stayed in the hysteresis window for 240 ns (typ.) and the tri-state detection signal has been driven high, the transistor M1 is turned off. From this circuit configuration, we can see that the voltage on the PWM pin when open-circuit will be about 2.5 V, so the tri-state protection function will operate.

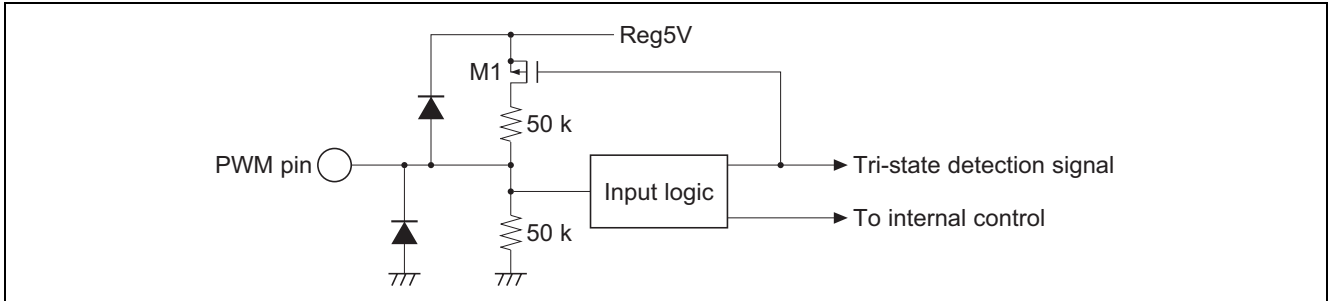

Figure 2 Equivalent Circuit for the PWM-pin Input

For the high-side driver, the BOOT pin is the power-supply voltage pin and voltage VSWH provides a standard for operation of the high-side driving circuit. Consequently, the difference between the voltage on the BOOT and VSWH pins becomes the gate swing for the high-side MOS FET. Connect a bootstrap capacitor between the BOOT pin and the VSWH pin. Since the Schottky barrier diode (SBD) is connected between the BOOT and Reg5V pins, this bootstrap capacitor is charged up to 5 V. When the high-side MOS FET is turned on, voltage VSWH becomes equal to VIN, so VBOOT is boosted to VSWH + 5 V.

The GH and GL pins are the gate-monitor pins for each MOS FET.

MOS FETs

The MOS FETs incorporated in R2J20601NP are highly suitable for synchronous-rectification buck conversion. For the high-side MOS FET, the drain is connected to the VIN pin and the source is connected to the VSWH pin. For the low-side MOS FET, the drain is connected to the VSWH pin and the source is connected to the PGND pin.

R2J20601NP

Package Dimensions

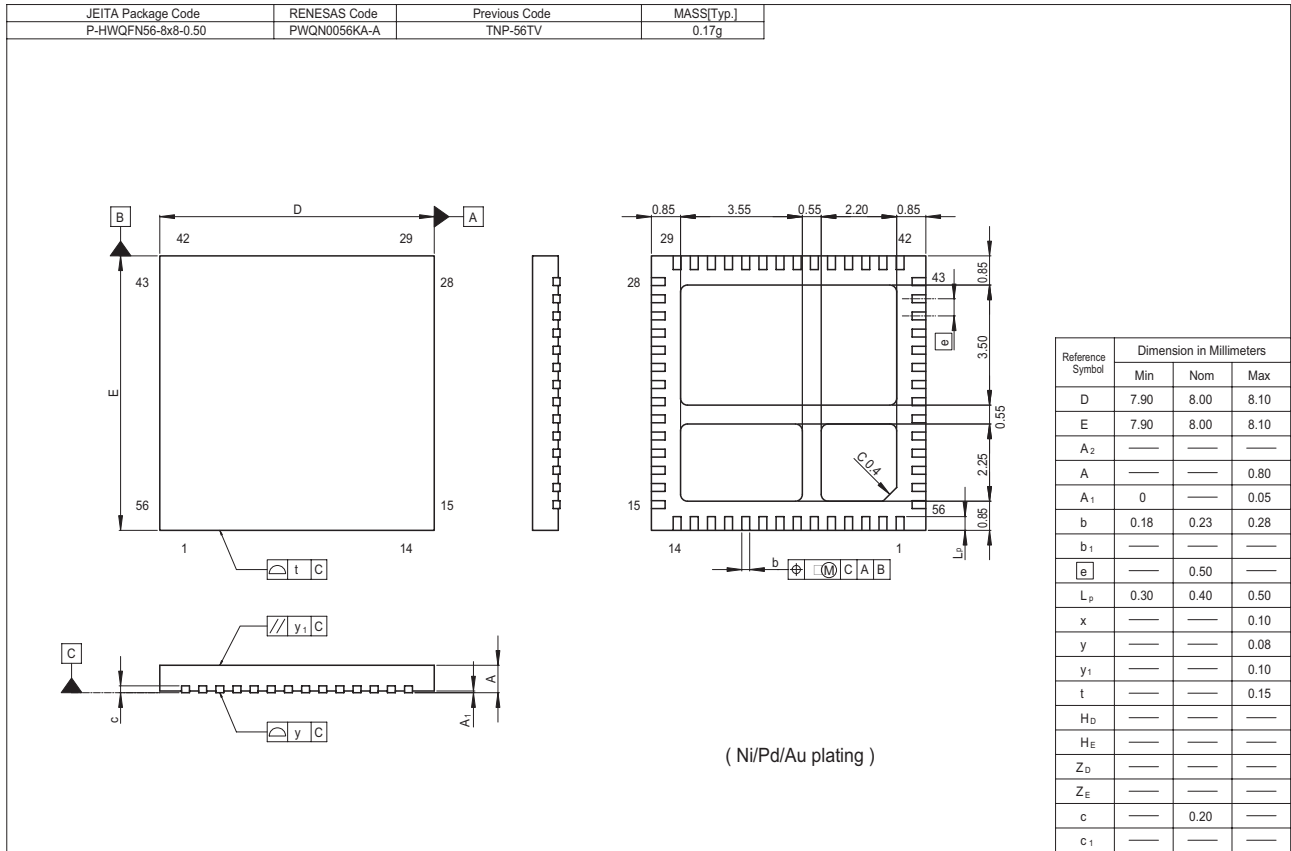

Renesas Technology Corp. Sales Strategic Planning Div. Nippon Bldg., 2-6-2, Ohte-machi, Chiyoda-ku, Tokyo 100-0004, Japan

Keep safety first in your circuit designs!

1. Renesas Technology Corp. puts the maximum effort into making semiconductor products better and more reliable, but there is always the possibility that trouble may occur with them. Trouble with semiconductors may lead to personal injury, fire or property damage. Remember to give due consideration to safety when making your circuit designs, with appropriate measures such as (i) placement of substitutive, auxiliary circuits, (ii) use of nonflammable material or (iii) prevention against any malfunction or mishap.

Notes regarding these materials

1. These materials are intended as a reference to assist our customers in the selection of the Renesas Technology Corp. product best suited to the customer's application; they do not convey any license under any intellectual property rights, or any other rights, belonging to Renesas Technology Corp. or a third party.
2. Renesas Technology Corp. assumes no responsibility for any damage, or infringement of any third-party's rights, originating in the use of any product data, diagrams, charts, programs, algorithms, or circuit application examples contained in these materials.
3. All information contained in these materials, including product data, diagrams, charts, programs and algorithms represents information on products at the time of publication of these materials, and are subject to change by Renesas Technology Corp. without notice due to product improvements or other reasons. It is therefore recommended that customers contact Renesas Technology Corp. or an authorized Renesas Technology Corp. product distributor for the latest product information before purchasing a product listed herein.
The information described here may contain technical inaccuracies or typographical errors.
Renesas Technology Corp. assumes no responsibility for any damage, liability, or other loss rising from these inaccuracies or errors.
Please also pay attention to information published by Renesas Technology Corp. by various means, including the Renesas Technology Corp. Semiconductor home page (<http://www.renesas.com>).
4. When using any or all of the information contained in these materials, including product data, diagrams, charts, programs, and algorithms, please be sure to evaluate all information as a total system before making a final decision on the applicability of the information and products. Renesas Technology Corp. assumes no responsibility for any damage, liability or other loss resulting from the information contained herein.
5. Renesas Technology Corp. semiconductors are not designed or manufactured for use in a device or system that is used under circumstances in which human life is potentially at stake. Please contact Renesas Technology Corp. or an authorized Renesas Technology Corp. product distributor when considering the use of a product contained herein for any specific purposes, such as apparatus or systems for transportation, vehicular, medical, aerospace, nuclear, or undersea repeater use.
6. The prior written approval of Renesas Technology Corp. is necessary to reprint or reproduce in whole or in part these materials.
7. If these products or technologies are subject to the Japanese export control restrictions, they must be exported under a license from the Japanese government and cannot be imported into a country other than the approved destination.
Any diversion or reexport contrary to the export control laws and regulations of Japan and/or the country of destination is prohibited.
8. Please contact Renesas Technology Corp. for further details on these materials or the products contained therein.



RENESAS SALES OFFICES

<http://www.renesas.com>

Refer to "<http://www.renesas.com/en/network>" for the latest and detailed information.

Renesas Technology America, Inc.

450 Holger Way, San Jose, CA 95134-1368, U.S.A
Tel: <1> (408) 382-7500, Fax: <1> (408) 382-7501

Renesas Technology Europe Limited

Dukes Meadow, Millboard Road, Bourne End, Buckinghamshire, SL8 5FH, U.K.
Tel: <44> (1628) 585-100, Fax: <44> (1628) 585-900

Renesas Technology (Shanghai) Co., Ltd.

Unit 204, 205, AZIACenter, No.1233 Lujiazui Ring Rd, Pudong District, Shanghai, China 200120
Tel: <86> (21) 5877-1818, Fax: <86> (21) 6887-7898

Renesas Technology Hong Kong Ltd.

7th Floor, North Tower, World Finance Centre, Harbour City, 1 Canton Road, Tsimshatsui, Kowloon, Hong Kong
Tel: <852> 2265-6688, Fax: <852> 2730-6071

Renesas Technology Taiwan Co., Ltd.

10th Floor, No.99, Fushing North Road, Taipei, Taiwan
Tel: <886> (2) 2715-2888, Fax: <886> (2) 2713-2999

Renesas Technology Singapore Pte. Ltd.

1 Harbour Front Avenue, #06-10, Keppel Bay Tower, Singapore 098632
Tel: <65> 6213-0200, Fax: <65> 6278-8001

Renesas Technology Korea Co., Ltd.

Kukje Center Bldg. 18th Fl., 191, 2-ka, Hangang-ro, Yongsan-ku, Seoul 140-702, Korea
Tel: <82> (2) 796-3115, Fax: <82> (2) 796-2145

Renesas Technology Malaysia Sdn. Bhd

Unit 906, Block B, Menara Amcorp, Amcorp Trade Centre, No.18, Jalan Persiaran Barat, 46050 Petaling Jaya, Selangor Darul Ehsan, Malaysia
Tel: <603> 7955-9390, Fax: <603> 7955-9510

