



TELEPHONE SPEECH CIRCUIT WITH MULTIFREQUENCY TONE GENERATOR INTERFACE

The LS156 is a monolithic integrated circuit in 16-lead dual in-line plastic package to replace the hybrid circuit in telephone set. It works with the same type of transducers for both transmitter and receiver (typically piezoceramic capsules, but the device can work also with dynamic ones). Many of its electrical characteristics can be controlled by means of external components to meet different specifications.

In addition to the speech operation, the LS156 acts as an interface for the MF tone signal (particularly for M761 C/MOS frequency synthesizer). The LS156 basic functions are the following:

- It presents the proper DC path for the line current.
- It handles the voice signal, performing the 2/4 wires interface and changing the gain on both

sending and receiving amplifiers to compensate for line attenuation by sensing the line length through the line current.

- It acts as linear interface for MF, supplying a stabilized to the digital chip and delivering to the line the MF tones generated by the M761.

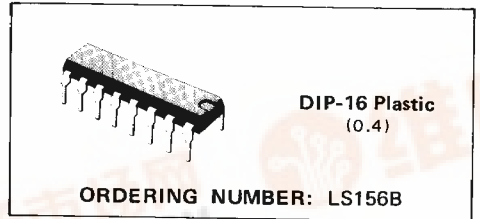

BLOCK DIAGRAM

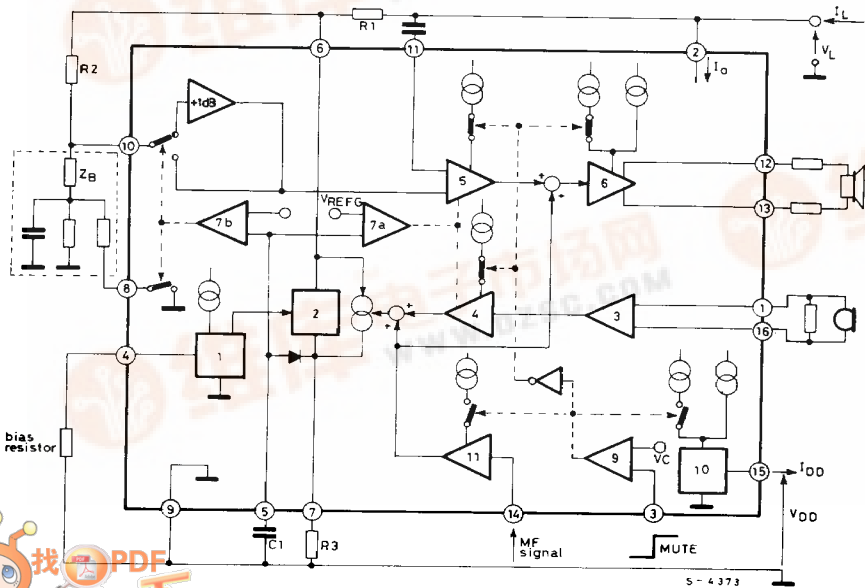

LS156

ABSOLUTE MAXIMUM RATINGS

V_L	Line voltage (3 ms pulse duration)	22	V
I_L	Forward line current	150	mA
I_L	Reverse line current	-150	mA
P_{tot}	Total power dissipation at $T_{amb} = 70^\circ\text{C}$	1	W
T_{op}	Operating temperature	-45 to 70	$^\circ\text{C}$
T_{stg}, T_j	Storage and junction temperature	-65 to 150	$^\circ\text{C}$

CONNECTION DIAGRAM

(top view)

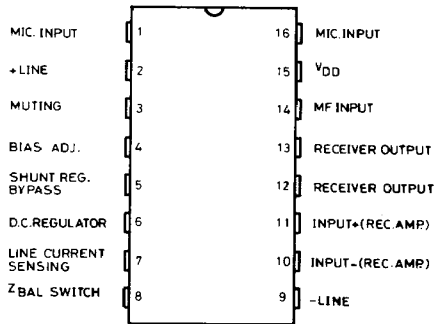

S-3838 /1

THERMAL DATA

$R_{th\ j-amb}$	Thermal resistance junction-ambient	max	80	$^\circ\text{C}/\text{W}$
-----------------	-------------------------------------	-----	----	---------------------------

TEST CIRCUITS

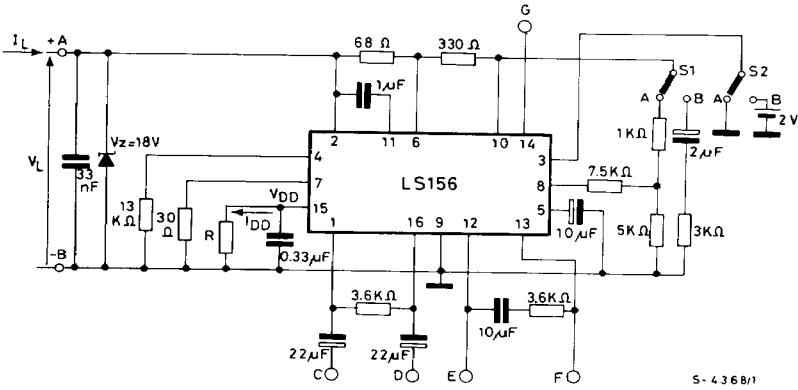
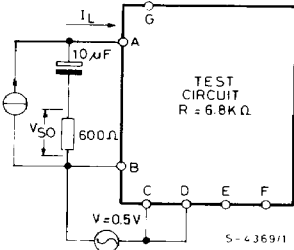
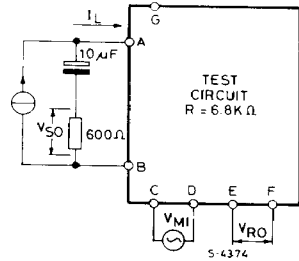

Fig. 1



$$V = 0,5V; \text{CMRR}$$

Fig. 2



$$\text{Side tone} = \frac{V_{RO}}{V_{M1}}; G_S = \frac{V_{SO}}{V_{M1}}$$

Fig. 3

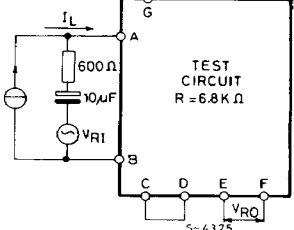

$$G_R = \frac{V_{RO}}{V_{R1}}$$

Fig. 4

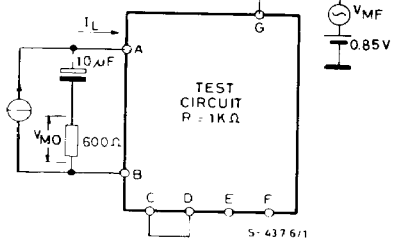

$$G_{MF} = \frac{V_{M0}}{V_{MF}}$$

LS156

ELECTRICAL CHARACTERISTICS (Refer to the test circuits, S1 and S2 in (a), $T_{amb} = -25$ to $+50^{\circ}\text{C}$, $f = 200$ to 3400 Hz, unless otherwise specified)

Parameter		Test condition		Min.	Typ.	Max.	Unit	Fig.
SPEECH OPERATION								
V_L	Line voltage	$T_{amb} = 25^{\circ}\text{C}$	$I_L = 12\text{ mA}$ $I_L = 20\text{ mA}$ $I_L = 80\text{ mA}$	3.9		4.7 5.5 12.2	V	—
CMRR	Common mode rejection	$f = 1\text{ KHz}$	$I_L = 12$ to 80 mA	50			dB	1
G_S	Sending gain	$T_{amb} = 25^{\circ}\text{C}$ $f = 1\text{ KHz}$ $V_{MI} = 2\text{ mV}$	$I_L = 52\text{ mA}$ $I_L = 25\text{ mA}$	44 48	45 49	46 50	dB	2
	Sending gain flatness	$V_{MI} = 2\text{ mV}$	$f_{ref} = 1\text{ KHz}$ $I_L = 12$ to 80 mA			± 1	dB	2
	Sending distortion	$f = 1\text{ KHz}$ $I_L = 16$ to 80 mA	$V_{so} = 1\text{ V}$ $V_{so} = 1.3\text{ V}$			2 10	%	2
	Sending noise	$V_{MI} = 0\text{ V}$	$I_L = 40\text{ mA}$		-70		dBmp	2
	Microphone input impedance pin 1-16	$V_{MI} = 2\text{ mV}$	$I_L = 12$ to 80 mA	40			$\text{K}\Omega$	
	Sending loss in MF operation	$V_{MI} = 2\text{ mV}$ S_2 in (b)	$I_L = 52\text{ mA}$ $I_L = 25\text{ mA}$	-30 -30			dB	2
G_R	Receiving gain	$V_{R1} = 0.3\text{ V}$ $f = 1\text{ KHz}$ $T_{amb} = 25^{\circ}\text{C}$	$I_L = 52\text{ mA}$ $I_L = 25\text{ mA}$	3 7	4 8	5 9	dB	3
	Receiving gain flatness	$V_{R1} = 0.3\text{ V}$	$f_{ref} = 1\text{ KHz}$ $I_L = 12$ to 80 mA			± 1	dB	3
	Receiving distortion	$f = 1\text{ KHz}$	$I_L = 12\text{ mA}$ $V_{RO} = 1.6\text{ V}$ $I_L = 12\text{ mA}$ $V_{RO} = 1.9\text{ V}$ $I_L = 50\text{ mA}$ $V_{RO} = 1.8\text{ V}$ $I_L = 50\text{ mA}$ $V_{RO} = 2.1\text{ V}$			2 10 2 10	%	3
	Receiving noise	$V_{R1} = 0\text{ V}$	$I_L = 12$ to 80 mA		150		μV	3
	Receiver output impedance pin 12-13	$V_{RO} = 50\text{ mV}$	$I_L = 40\text{ mA}$			100	Ω	
	Sidetone	$f = 1\text{ KHz}$ $T_{amb} = 25^{\circ}\text{C}$ S_1 in (b)	$I_L = 52\text{ mA}$ $I_L = 25\text{ mA}$			36 36	dB	2
Z_{ML}	Line matching impedance	$V_{R1} = 0.3\text{ V}$	$f = 1\text{ KHz}$ $I_L = 12$ to 80 mA	500	600	700	Ω	3



ELECTRICAL CHARACTERISTICS (continued)

Parameter	Test condition	Min.	Typ.	Max.	Unit	Fig.
-----------	----------------	------	------	------	------	------

MULTIFREQUENCY SYNTHESIZER INTERFACE

V_{DD}	MF supply voltage (Standby and operation)	$I_L = 12$ to 80 mA	2.4	2.5		V	—
I_{DD}	MF supply current Stand by Operation	$I_L = 12$ to 80 mA $I_L = 12$ to 80 mA; S_2 in (b)	0.5 2			mA	—
	MF amplifier gain	$I_L = 12$ to 80 mA $f_{MF\ in} = 1$ KHz $V_{MF\ in} = 80$ mV	15		17	dB	4
V_i	DC input voltage level (pin 14)	$V_{M\ Fin} = 80$ mV		.3 V_{DD}		V	—
R_i	Input impedance (pin 14)	$V_{M\ Fin} = 80$ mV	60			K Ω	—
d	Distortion	$V_{M\ Fin} = 110$ mV $I_L = 12$ to 80 mA			2	%	4
	Starting delay time	$I_L = 12$ to 80 mA			5	ms	—
	Muting threshold voltage (pin 3)	Speech operation			1	V	—
		MF Operation	1.6			V	—
	Muting stand by current (pin 3)	$I_L = 12$ to 80 mA			-10	μ A	—
	Muting operating current (pin 3)	$I_L = 12$ to 80 mA S_2 in (b)			+10	μ A	—



LS156

CIRCUIT DESCRIPTION

1. DC characteristic

In accordance with CCITT recommendations, any device connected to a telephone line must exhibit a proper DC characteristics V_L , I_L .

The DC characteristic of the LS 156 is determined by the shunt regulator (block 2) together with two series resistors R_1 and R_3 . The equivalent circuit of the total system is shown in fig. 5.

Fig. 5 - Equivalent DC load to the line

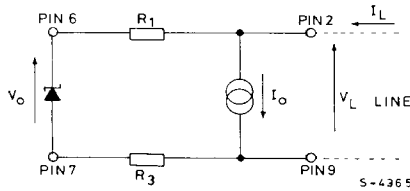

A fixed amount I_o of the total available current I_L is drained for the proper operation of the circuit. The value of I_o can be programmed externally by changing the value of the bias resistor connected to pin 4 (see block diagram).

The recommended minimum of I_o is 7.5 mA.

The voltage $V_o \cong 3.8V$ of the shunt regulator is independent of the line current.

The shunt regulator (2) is controlled by a temperature compensated voltage reference (1) (see the block diagram).

Fig. 6 shows a more detailed circuit configuration of the shunt regulator.

Fig. 6 - Circuit configuration of the shunt regulator

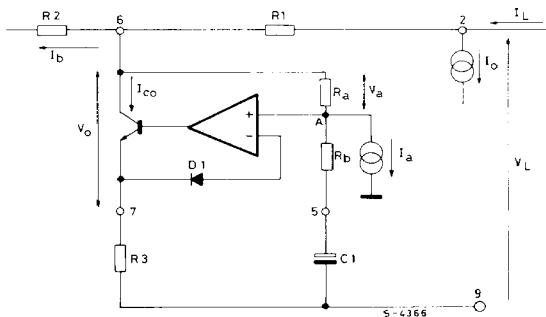

CIRCUIT DESCRIPTION (continued)

The difference $I_L - I_o$ flows through the shunt regulator being I_b negligible.

I_a is an internal constant current generator; hence $V_o = V_{BED1} + I_a \cdot R_a \cong 3.8V$. The V_L, I_L characteristic of the device is therefore similar to a pure resistance in series to a battery.

It is important to note that the DC voltage at pin 5 is proportional to the line current ($V_5 = V_7 + V_{BED1} \cong (I_L - I_o) R_3 + V_{BED1}$).

2. 2/4 wires conversion

The LS156 performs the two wires (line) to four wires (microphone, earphone) conversion by means of a Wheatstone bridge configuration so obtaining the proper decoupling between sending and receiving signals (see fig. 7).

Fig. 7 - Two to four wires conversion

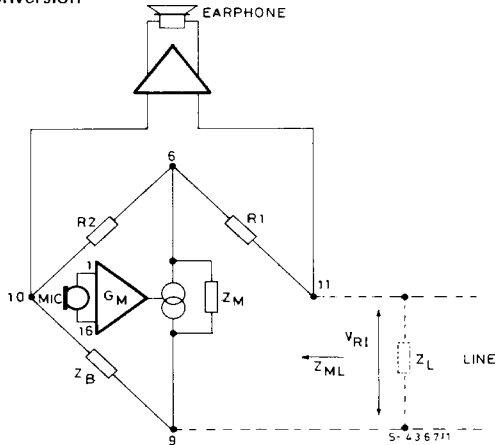

For a perfect balancing of the bridge $\frac{Z_L}{Z_B} = \frac{R_1}{R_2}$.

The AC signal from the microphone is sent to one diagonal of the bridge (pin 6 and 9). A small percentage of the signal power is lost on Z_B (being $Z_B \gg Z_L$); the main part is sent to the line via R_1 .

In receiving mode, the AC signal coming from the line is sensed across the second diagonal of the bridge (pin 11 and 10). After amplification it is applied to the receiving capsule.

The impedance Z_M is simulated by the shunt regulator that is also intended to work as a transconductance amplifier for the transmission signal.

The impedance Z_M is defined as $\frac{\Delta V_{6-9}}{\Delta I_{6-9}}$.

From fig. 6, considering C_1 as a short circuit for AC signal, any variation ΔV_6 generates a variation.

$$\Delta V_7 = \Delta V_A = \Delta V_6 \cdot \frac{R_b}{R_a + R_b}$$

LS156

CIRCUIT DESCRIPTION (continued)

The corresponding current change is

$$\Delta I = \frac{\Delta V_7}{R_3}$$

Therefore

$$Z_M = \frac{\Delta V_6}{\Delta I} = R_3 \left(1 + \frac{R_a}{R_b} \right)$$

The total impedance across the line connections (pin 11 and 9) is given by

$$Z_{ML} = R_1 + Z_M // (R_2 + Z_B)$$

By choosing $Z_M \gg R_1$ and $Z_B \gg Z_M$

$$Z_{ML} \cong Z_M = R_3 \left(1 + \frac{R_a}{R_b} \right)$$

The received signal amplitude across pin 11 and 10 can be changed using different values of R_1 (of course the relationship $\frac{Z_L}{Z_B} = \frac{R_1}{R_2}$ must be always valid).

The received signal is related to R_1 value according to the approximated relationship

$$V_R = 2 \cdot V_{RI} \frac{R_1}{R_1 + Z_M}$$

Note that by changing the value of R_1 , the transmission signal current is not changed, being the microphone amplifier a transconductance amplifier.

3. Automatic gain control

The LS156 automatically adjusts the gain of the sending and receiving amplifiers to compensate for line attenuation by sensing the line length through the line current.

The line current is sensed across R_3 (see fig. 6) and transferred to pin 5 by the regulator.

$$V_5 = V_{BED1} + V_7 \cong V_{BED1} + (I_L - I_o) \cdot R_3.$$

The pin 5 V_5 voltage, after a comparison with an internal reference V_{REFG} (see the block diagram) is used to modify the gain of the amplifiers (4) and (5) on both the sending and receiving path.

The starting point of the automatic level control is obtained at $I_L = 25$ mA when the drain current $I_o = 7.5$ mA.

Minimum gain is reached for a line current of about 52 mA for the same drain current $I_o = 7.5$ mA. When I_o is increased by means of the external resistor connected to pin 4, the two above mentioned values of the line current for the starting point and for the minimum gain increase accordingly.

Automatic switching of the balance network Z_B for a better sidetone is performed by the LS156 through V_5 information. This information, proportional to the line length, drives the comparator (7b) (see the block diagram).

For long lines, the impedance level of Z_B is high (pin 8 open) and the additional +1 dB gain is added to the receiving amplifier chain.



CIRCUIT DESCRIPTION (continued)

For short lines, the impedance level of Z_B is automatically switched to a lower value (pin 8 shorted to ground) and the additional +1 dB block is bypassed by the received signal. A built in hysteresis circuit avoids uncertain operation of the comparator.

4. Transducers interfacing

The microphone amplifier (3) has a differential input stage with high impedance ($\cong 40\text{ K}\Omega$) so allowing a good matching to the microphone by means of external resistors without affecting the sending gain. The receiving output stage (6) is particularly intended to drive piezoceramic capsules. [Low output impedance (100Ω max); high voltage swing (close to V_L); current capability of 1.8 mA].

When a dynamic capsule is used, it is useful to decrease the receiving gain by decreasing R_1 value (see the relationship for V_R).

With very low impedance transducer, DC decoupling by an external capacitor must be provided to prevent a large DC current flow across the transducer itself due to the receiving output stage offset.

5. Multifrequency interfacing

The LS156 acts as a linear interface for the Multifrequency synthesizer M761 according to a logical signal (mute function) present on pin 3.

When no key of the keyboard is pressed the mute state is low and the LS156 feeds the M761 through pin 15 with low current (standby operation of the M761). The oscillator of the M761 is not operating. When one key is pressed, the M761 sends a "high state" mute condition to the LS156. A voltage comparator (9) of LS156 drives internal electronic switches: the current delivered by the voltage supply (10) is increased to allow the operation of the oscillator. This extra current is diverted by the receiving and sending section of the LS156 and during this operation the receiving output stage is partially inhibited and the input stages of sending and receiving amplifiers are switched OFF.

A controlled amount of the signalling is allowed to reach the earphone to give a feedback to the subscriber; the MF amplifier (11) delivers the dial tones to the sending paths.

The application circuit shown in fig. 9 fulfils the EUROPE II standard (-6, -8 dBm). If the EUROPE I levels are required (-9, -11 dBm), an external divider must be used (fig. 11). The mute function can be used also when a temporary inhibition of the output signal is requested.

APPLICATION INFORMATION

Fig. 8 - Application circuit with multifrequency (EUROPE II std.)

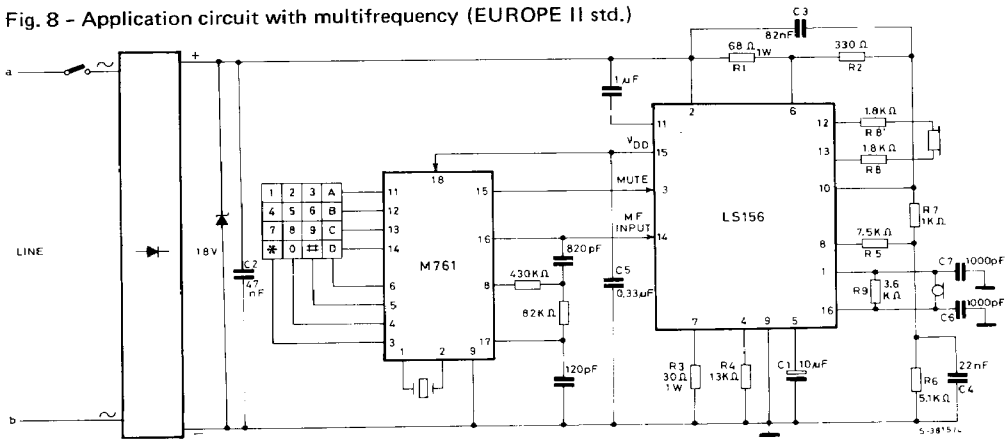

LS156

APPLICATION INFORMATION (continued)

Fig. 9 - Application circuit with multifrequency (EUROPE I std.)

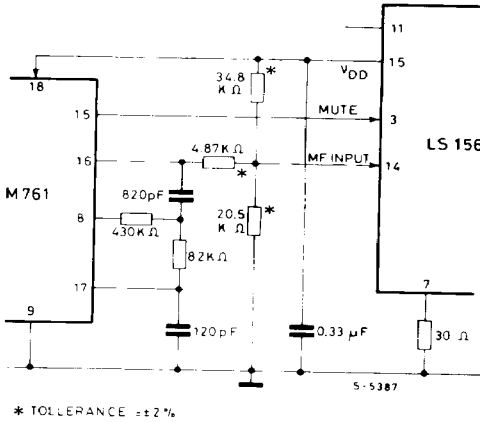

Fig. 10 - External mute function

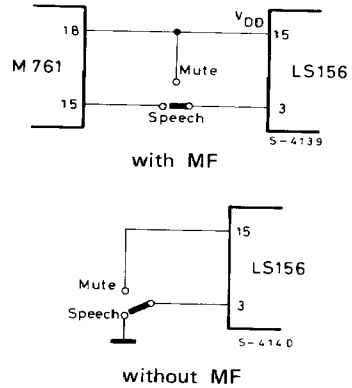
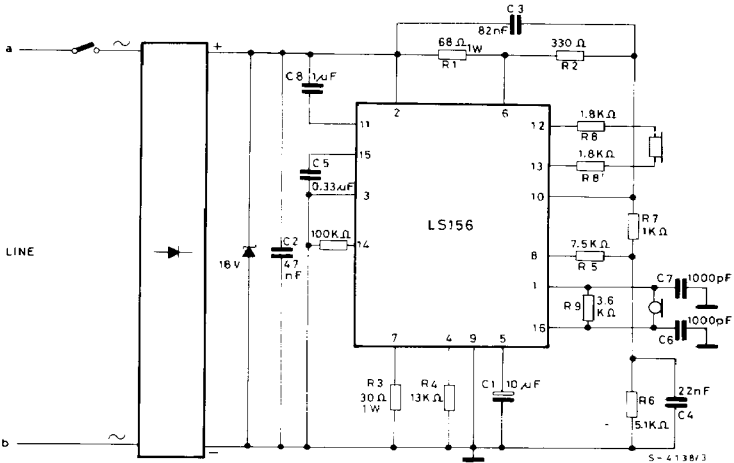

Fig. 11 - Application circuit without multifrequency.



The circuits shown in fig. 8 and fig. 11 are referred to the Italian standard. The fig. 10 shows the connection for mute function (inhibition of the output stage when it is requested) by using an external switch at pin 3.

Different values for the external components can be used in order to satisfy different requirements. The following table can help the designer.

APPLICATION INFORMATION (continued)

Component	Value	Purpose	Note
R ₁	68 Ω	Bridge Resistors	R ₁ controls the receiving gain. The ratio R ₂ /R ₁ fixes the amount of signal delivered to the line. R ₁ helps in fixing the DC characteristic (see R ₃ note).
R ₂	330 Ω		
R ₃	30 Ω	Line current sensing. Fixing DC characteristic.	The relationships involving R ₃ are: <ul style="list-style-type: none"> • $Z_{ML} = (20 R_3 // Z_B) + R_1$ • $G_s = K \cdot \frac{Z_L // Z_{ML}}{R_3}$ • $V_L = (I_L - I_o) (R_3 + R_1) + V_o$; $V_o = 3.8V$. Without any problem it is possible to have a Z_{ML} ranging from 500 up to 900 Ω.
R ₄	13 KΩ	Bias Resistor	The suggested value assures the minimum operating current. It is possible to increase the supply current by decreasing R ₄ (they are inversely proportional), in order to achieve the shifting of the AGC starting point. (See fig. 12).
R ₅	7.5 KΩ	Balance Network	The balance network has two possible impedance levels, selected by the circuit referring to the line current (i.e. to the line length) in order to optimize the sidetone. It's possible to change R ₅ , R ₆ , R ₇ values in order to improve the matching to different lines; in any case: $\frac{Z_B}{Z_L} = \frac{R_2}{R_1}$ with the two possible values for Z _B : $Z_{B(1)} = R_7 + R_6 // C_4 \text{ (long lines)}$ $Z_{B(2)} = R_7 + (R_6 // R_5) // C_4 \text{ (short lines)}$ (see fig. 13).
R ₆	5.1 KΩ		
R ₇	1 KΩ		
R ₈ - R ₈ '	1.8 KΩ	Receiver impedance matching	R ₈ and R ₈ ' must be equal; the suggested value is good for matching to piezoceramic capsule; there is no problem in increasing and decreasing (down to 0 Ω) this value, but when low resistance levels are used a DC decoupling must be inserted to stop the current due to the receiver output offset voltage (max 400 mV).
R ₉	3.6 KΩ	Microphone impedance matching	The suggested value is typical for a piezoceramic microphone, but it is possible to choose R ₉ in a wide range.
C ₁	10 μF	Regulator AC bypass	A value greater than 10 μF gives a system start time too high for low current line during MF operation; a lower value gives an alteration of the AC line impedance at low frequency.
C ₂	47 nF	Matching to a capacitive line	C ₂ changes with the characteristics of the transmission line.



LS156

APPLICATION INFORMATION (continued)

Component	Value	Purpose	Note
C ₃	82 nF	Receiving gain flatness.	C ₃ depends on balancing and line impedance versus frequency.
C ₄	22 nF	Balance network.	See note for R ₇ , R ₆ , R ₅ .
C ₅	0.33 μF	DC filtering	The C ₅ range is from 0.1 μF to 0.47 μF. The lowest value is ripple limited, the higher value is starting up time limited.
C ₆ - C ₇	1000 pF	RF bypass.	
C ₈	1 μF	DC decoupling for receiving input.	

Fig. 12 - Sending and receiving gain vs. line current

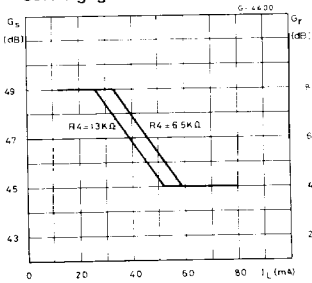

Fig. 13 - Balance network impedance vs. line current

