

www.DataSheet4U.com

Navigator™ Motion Processor

MC2300 Series

Technical Specifications

for Brushless Servo Motion Control

www.DataSheet4U.com

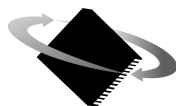

P M D

Performance Motion Devices, Inc.
55 Old Bedford Road
Lincoln, MA 01773

www.DataSheet4U.com

Revision 1.7, April 2002

NOTICE

This document contains proprietary and confidential information of Performance Motion Devices, Inc., and is protected by federal copyright law. The contents of this document may not be disclosed to third parties, translated, copied, or duplicated in any form, in whole or in part, without the express written permission of PMD.

The information contained in this document is subject to change without notice. No part of this document may be reproduced or transmitted in any form, by any means, electronic or mechanical, for any purpose, without the express written permission of PMD.

Copyright 1998, 1999 by Performance Motion Devices, Inc.

Navigator and **C-Motion** are trademarks of Performance Motion Devices, Inc

Warranty

PMD warrants performance of its products to the specifications applicable at the time of sale in accordance with PMD's standard warranty. Testing and other quality control techniques are utilized to the extent PMD deems necessary to support this warranty. Specific testing of all parameters of each device is not necessarily performed, except those mandated by government requirements.

Performance Motion Devices, Inc. (PMD) reserves the right to make changes to its products or to discontinue any product or service without notice, and advises customers to obtain the latest version of relevant information to verify, before placing orders, that information being relied on is current and complete. All products are sold subject to the terms and conditions of sale supplied at the time of order acknowledgement, including those pertaining to warranty, patent infringement, and limitation of liability.

Safety Notice

Certain applications using semiconductor products may involve potential risks of death, personal injury, or severe property or environmental damage. Products are not designed, authorized, or warranted to be suitable for use in life support devices or systems or other critical applications. Inclusion of PMD products in such applications is understood to be fully at the customer's risk.

In order to minimize risks associated with the customer's applications, adequate design and operating safeguards must be provided by the customer to minimize inherent procedural hazards.

Disclaimer

PMD assumes no liability for applications assistance or customer product design. PMD does not warrant or represent that any license, either express or implied, is granted under any patent right, copyright, mask work right, or other intellectual property right of PMD covering or relating to any combination, machine, or process in which such products or services might be or are used. PMD's publication of information regarding any third party's products or services does not constitute PMD's approval, warranty or endorsement thereof.

Related Documents

Navigator Motion Processor User's Guide (MC2000UG)

How to set up and use all members of the Navigator Motion Processor family.

Navigator Motion Processor Programmer's Reference (MC2000PR)

Descriptions of all Navigator Motion Processor commands, with coding syntax and examples, listed alphabetically for quick reference.

Navigator Motion Processor Technical Specifications

Four booklets containing physical and electrical characteristics, timing diagrams, pinouts, and pin descriptions of each series:

- MC2100 series, for brushed servo motion control (MC2100TS);

- MC2300 series, for brushless servo motion control (MC2300TS);

- MC2400 series, for microstepping motion control (MC2400TS);

- MC2500 series, for stepping motion control (MC2500TS);

- MC2800 Series, for brushed servo and brushless servo motion control (MC2800TS).

Navigator Motion Processor Developer's Kit Manual (DK2000M)

How to install and configure the DK2000 developer's kit PC board.

Table of Contents

Warranty.....	iii
Safety Notice	iii
Disclaimer.....	iii
Related Documents.....	v
Table of Contents.....	vii
1 The Navigator Family	9
2 Functional Characteristics.....	11
2.1 Configurations, parameters, and performance	11
2.2 Physical characteristics and mounting dimensions	13
2.2.1 CP chip	13
2.2.2 I/O chip.....	14
2.3 Environmental and electrical ratings	15
2.4 System configuration	15
2.5 Peripheral device address mapping.....	16
3 Electrical Characteristics.....	17
3.1 DC characteristics.....	17
3.2 AC characteristics.....	17
4 I/O Timing Diagrams	19
4.1 Clock	19
4.2 Quadrature encoder input	19
4.3 Reset.....	19
4.4 Host interface, 8/8 mode.....	20
4.4.1 Instruction write, 8/8 mode.....	20
4.4.2 Data write, 8/8 mode	20
4.4.3 Data read, 8/8 mode.....	21
4.4.4 Status read, 8/8 mode.....	21
4.5 Host interface, 8/16 mode.....	22
4.5.1 Instruction write, 8/16 mode.....	22
4.5.2 Data write, 8/16 mode.....	22
4.5.3 Data read, 8/16 mode.....	23
4.5.4 Status read, 8/16 mode.....	23
4.6 Host interface, 16/16 mode.....	24
4.6.1 Instruction write, 16/16 mode.....	24
4.6.2 Data write, 16/16 mode.....	24
4.6.3 Data read, 16/16 mode.....	25
4.6.4 Status read, 16/16 mode.....	25
4.7 External memory timing	26
4.7.1 External memory read.....	26
4.7.2 External memory write	26
4.8 Peripheral device timing	27
4.8.1 Peripheral device read.....	27
4.8.2 Peripheral device write	27

5 Pinouts and Pin Descriptions.....	28
5.1 Pinouts for MC2340	28
5.2 Pinouts for MC2320	29
5.3 Pinouts for MC2310	30
5.4 Pin description tables.....	31
5.4.1 I/O chip.....	31
5.4.2 CP chip	34
6 Application Notes.....	38
6.1 Design Tips.....	38
6.2 ISA Bus Interface	40
6.3 RS-232 Serial Interface	42
6.4 RS 422/485 Serial Interface.....	44
6.5 PWM Motor Interface	46
6.6 12-bit Parallel DAC Interface.....	48
6.7 16-bit Serial DAC Interface.....	50
6.8 12-bit A/D Interface.....	52
6.9 16-bit A/D Input	54
6.10 RAM Interface.....	56
6.11 User-defined I/O	58

1 The Navigator Family

	MC2100 Series	MC2300 Series	MC2400 Series	MC2500 Series	MC2800 Series
# of axes	4, 2, or 1	4, 2 or 1	4, 2 or 1	4, 2, or 1	4 or 2
Motor type supported	Brushed servo	Brushless servo	Stepping	Stepping	Brushed servo + brushless servo
Output format	Brushed servo (single phase)	Commutated (6-step or sinusoidal)	Microstepping	Pulse and direction	Brushed servo (single phase) + commutated (6-step sinusoidal)
Incremental encoder input	✓	✓	✓	✓	✓
Parallel word device input	✓	✓	✓	✓	✓
Parallel communication	✓	✓	✓	✓	✓
Serial communication	✓	✓	✓	✓	✓
Diagnostic port	✓	✓	✓	✓	✓
S-curve profiling	✓	✓	✓	✓	✓
Electronic gearing	✓	✓	✓	✓	✓
On-the-fly changes	✓	✓	✓	✓	✓
Directional limit switches	✓	✓	✓	✓	✓
Programmable bit output	✓	✓	✓	✓	✓
Software-invertable signals	✓	✓	✓	✓	✓
PID servo control	✓	✓	-	-	✓
Feedforward (accel & vel)	✓	✓	-	-	✓
Derivative sampling time	✓	✓	-	-	✓
Data trace/diagnostics	✓	✓	✓	✓	✓
PWM output	✓	✓	✓	-	✓
Motion error detection	✓	✓	✓ (with encoder)	✓ (with encoder)	✓
Axis settled indicator	✓	✓	✓ (with encoder)	✓ (with encoder)	✓
DAC-compatible output	✓	✓	✓	-	✓
Pulse & direction output	-	-	-	✓	-
Index & Home signals	✓	✓	✓	✓	✓
Position capture	✓	✓	✓	✓	✓
Analog input	✓	✓	✓	✓	✓
User-defined I/O	✓	✓	✓	✓	✓
External RAM support	✓	✓	✓	✓	✓
Multi-chip synchronization	✓ (21x3)	✓ (23x3)	✓ (24x3)		✓ (28x3)
Chipset part numbers	MC2140 (4 axes) MC2120 (2 axes) MC2110 (1 axis)	MC2340 (4 axes) MC2320 (2 axes) MC2310 (1 axis)	MC2440 (4 axes) MC2420 (2 axes) MC2410 (1 axis)	MC2540 (4 axes) MC2520 (2 axes) MC2510 (1 axis)	MC2840 (4 axes) MC2820 (2 axes)
Developer's Kit p/n's:	DK2100	DK2300	DK2400	DK2500	DK2800

Introduction

This manual describes the operational characteristics of the MC2340, MC2320 and MC2310 Motion Processors from PMD. These devices are members of PMD's second-generation motion processor family, which consists of 14 separate products organized into 5 series.

Each of these devices are complete chip-based motion processors. They provide trajectory generation and related motion control functions. Depending on the type of motor controlled they provide servo loop closure, on-board commutation for brushless motors, and high speed pulse and direction outputs. Together these products provide a software-compatible family of dedicated motion processors that can handle a large variety of system configurations.

Each of these chips utilize a similar architecture, consisting of a high-speed computation unit, along with an ASIC (Application Specific Integrated Circuit). The computation unit contains special on-board hardware that makes it well suited for the task of motion control.

Along with similar hardware architecture these chips also share most software commands, so that software written for one chipset may be re-used with another, even though the type of motor may be different.

Each chipset consists of two PQFP (Plastic Quad Flat Pack) ICs: a 100-pin Input/Output (I/O) chip, and a 132-pin Command Processor (CP) chip.

The four different series in the Navigator family are designed for a particular type of motor or control scheme. Here is a summary description of each series.

Family Summary

MC2100 Series (MC2140, MC2120, MC2110) – This series outputs motor commands in either Sign/Magnitude PWM or DAC-compatible format for use with brushed servo motors, or with brushless servo motors having external commutation.

MC2300 Series (MC2340, MC2320, MC2310) – This series outputs sinusoidally commutated motor signals appropriate for driving brushless motors. Depending on the motor type, the output is a two-phase or three-phase signal in either PWM or DAC-compatible format.

MC2400 Series (MC2440, MC2420, MC2410) – This series provides microstepping signals for stepping motors. Two phased signals per axis are generated in either PWM or DAC-compatible format.

MC2500 Series (MC2540, MC2520, MC2510) – These chipsets provide high-speed pulse and direction signals for stepping motor systems.

MC2800 Series (MC2840, MC2820) – This series outputs sinusoidally or 6-step commutated motor signals appropriate for driving brushless servo motors as well as PWM or DAC-compatible outputs for driving brushed servo motors.

2 Functional Characteristics

2.1 Configurations, parameters, and performance

Available configurations	4 axes (MC2340), 2 axes (MC2320), or 1 axis (MC2310)
Operating modes	Closed loop (motor command is driven from output of servo filter) Open loop (motor command is driven from user-programmed register)
Communication modes	8/8 parallel (8 bit external parallel bus with 8 bit internal command word size) 8/16 parallel (8 bit external parallel bus with 16 bit internal command word size) 16/16 parallel (16 bit external parallel bus with 16 bit internal command word size) Point to point asynchronous serial Multidrop asynchronous serial
Serial port baud rate range	1,200 baud to 416,667 baud
Position range	-2,147,483,648 to +2,147,483,647 counts
Velocity range	-32,768 to +32,767 counts/sample with a resolution of 1/65,536 counts/sample
Acceleration/deceleration ranges	-32,768 to +32,767 counts/sample ² with a resolution of 1/65,536 counts/sample ²
Jerk range	0 to ½ counts/sample ³ , with a resolution of 1/4,294,967,296 counts/sample ³
Profile modes	S-curve point-to-point (Velocity, acceleration, jerk, and position parameters) Trapezoidal point-to-point (Velocity, acceleration, deceleration, and position parameters) Velocity-contouring (Velocity, acceleration, and deceleration parameters) Electronic Gear (Encoder or trajectory position of one axis used to drive a second axis. Master and slave axes and gear ratio parameters)
Electronic gear ratio range	-32,768 to +32,767 with a resolution of 1/65,536 (negative and positive direction)
Filter modes	Scalable PID + Velocity feedforward + Acceleration feedforward + Bias. Also includes integration limit, settable derivative sampling time, and output motor command limiting
Filter parameter resolution	16 bits
Position error tracking	Motion error window (allows axis to be stopped upon exceeding programmable window) Tracking window (allows flag to be set if axis exceeds a programmable position window) Axis settled (allows flag to be set if axis exceeds a programmable position window for a programmable amount of time after trajectory motion is complete)
Motor output modes	PWM (10-bit resolution at 20 kHz) DAC (16 bits)
Commutation rate	20KHz for MC2310 and MC2320, 10KHz for MC2340
Maximum encoder rate	Incremental (up to 5 Mcounts/sec) Parallel-word (up to 160 Mcounts/sec)
Parallel encoder word size	16 bits
Parallel encoder read rate	20 kHz (reads all axes every 50 μsec)
Hall sensor inputs	3 Hall effect inputs per axis (TTL level signals)
Servo loop timing range	153.6 μsec to 32.767 milliseconds

<i>Minimum servo loop time</i>	153.6 μ sec per enabled axis
<i>Multi-chip synchronization</i>	<10 μ sec difference between master and slave servo cycle MC23x3 chipset only
<i>Limit switches</i>	2 per axis: one for each direction of travel
<i>Position-capture triggers</i>	2 per axis: index and home signals
<i>Other digital signals (per axis)</i>	1 AxisIn signal per axis, 1 AxisOut signal per axis
<i>Software-invertable signals</i>	Encoder A, Encoder B, Index, Home, AxisIn, AxisOut, PositiveLimit, NegativeLimit, HallA, HallB, HallC (all individually programmable per axis)
<i>Analog input</i>	8 10-bit analog inputs
<i>User defined discrete I/O</i>	256 16-bit wide user defined I/O
<i>RAM/external memory support</i>	65,536 blocks of 32,768 16 bit words per block. Total accessible memory is 2,147,483,648 16 bit words
<i>Trace modes</i>	one-time continuous
<i>Max. number of trace variables</i>	4
<i>Number of traceable variables</i>	27
<i>Number of host instructions</i>	152

2.2 Physical characteristics and mounting dimensions

2.2.1 CP chip

All dimensions are in inches (with millimeters in brackets).

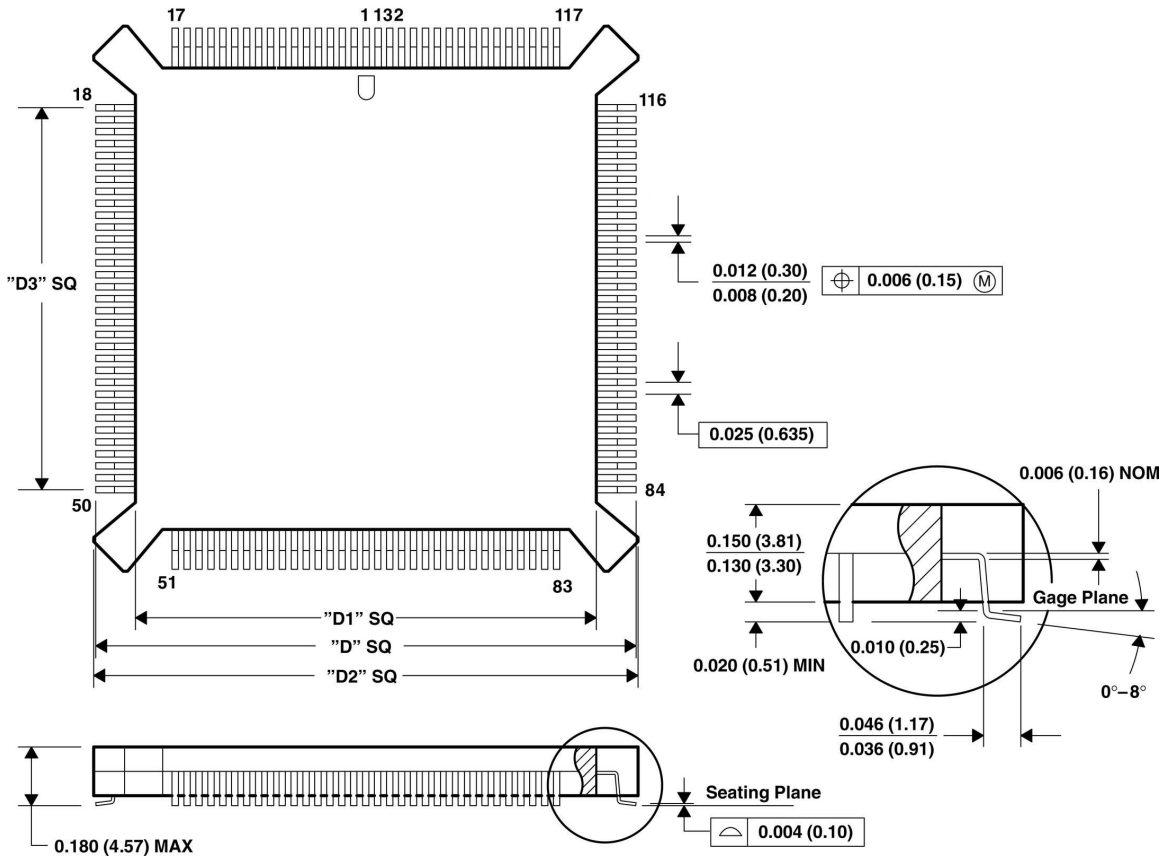

Dimension	Minimum (inches)	Maximum (inches)
D	1.070	1.090
D1	0.934	0.966
D2	1.088	1.112
D3	0.800 nominal	

2.2.2 I/O chip

All dimensions are in millimeters.

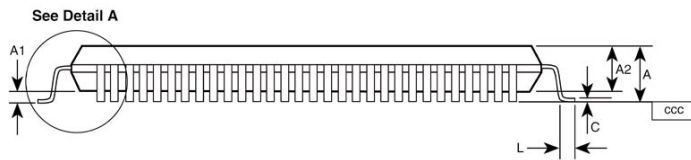
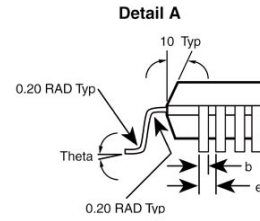
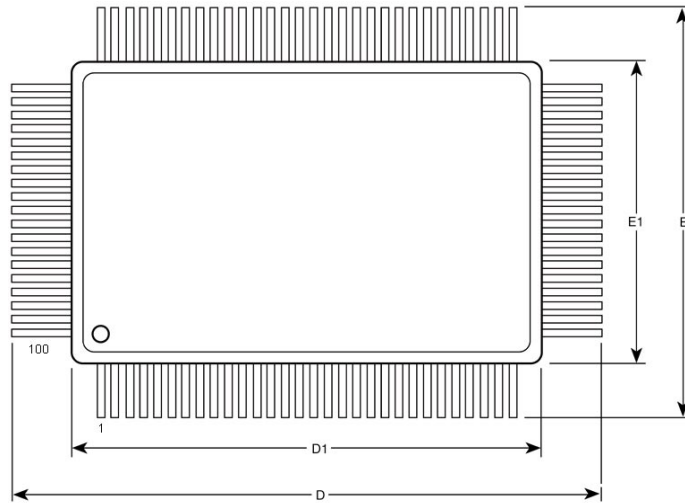

Dimension	Minimum (mm)	Nominal (mm)	Maximum (mm)
A			3.40
A1	0.25	0.33	
A2	2.55	2.80	3.05
b	0.22		0.38
c	0.13		0.23
D	22.95	23.20	23.45
D1	19.90	20.00	20.10
E	16.95	17.20	17.45
E1	13.90	14.00	14.01
e		0.65 BSC	
L	0.73	0.88	1.03
ccc			0.10
theta	0°		7°

2.3 Environmental and electrical ratings

All ratings and ranges are for both the I/O and CP chips.

Storage Temperature (T_s)	-55 °C to 150 °C
Operating Temperature (T_a)	0 °C to 70 °C*
Power Dissipation (P_d)	600 mW (I/O and CP combined)
Nominal Clock Frequency (F_{clk})	40.0 MHz
Supply Voltage limits (V_{cc})	-0.3V to +7.0V
Supply Voltage operating range (V_{cc})	4.75V to 5.25V

* An industrial version with an operating range of -40°C to 85°C is also available. Please contact PMD for more information.

2.4 System configuration

The following figure shows the principal control and data paths in an MC2300 system.

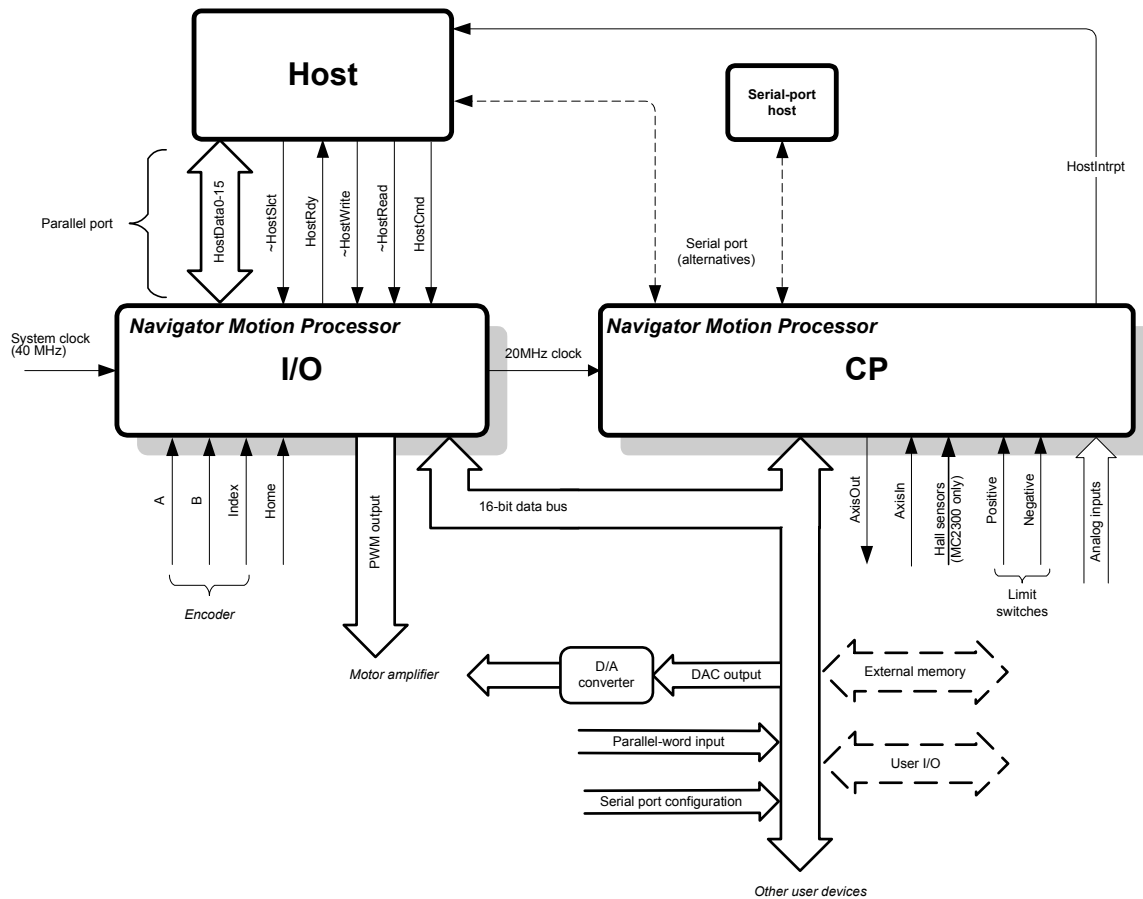

The CP chip contains the profile generator, which calculates velocity, acceleration, and position values for a trajectory; and the digital servo filter, which stabilizes the motor output signal. The filter produces one of two types of output:

- a Pulse-Width Modulated (PWM) signal output which passes via the data bus to the I/O chip, where the output signal generator sends it to the motor amplifiers; or

- a DAC-compatible value routed via the data bus to the appropriate D/A converter.

Axis position information returns to the motion processor through the I/O chip, in the form of encoder feedback, or through the CP chip, in the form of parallel-word feedback.

2.5 Peripheral device address mapping

Device addresses on the CP chip's data bus are memory-mapped to the following locations:

Address	Device	Description
0200h	Serial port data	Contains the configuration data (transmission rate, parity, stop bits, etc) for the asynchronous serial port
0800h	Parallel-word encoder	Base address for parallel-word feedback devices
1000h	User-defined	Base address for user-defined I/O devices
2000h	RAM page pointer	Page pointer to external memory
4000h	Motor-output DACs	Base address for motor-output D/A converters
8000h	I/O chip	Base address for I/O chip communications

3 Electrical Characteristics

3.1 DC characteristics

(V_{cc} and T_a per operating ratings, $F_{clk} = 40.0$ MHz)

Symbol	Parameter	Minimum	Maximum	Conditions
V_{cc}	Supply Voltage	4.75 V	5.25 V	
I_{dd}	Supply Current		120 mA	open outputs

Input Voltages

V_{ih}	Logic 1 input voltage	2.0 V	$V_{cc} + 0.3$ V	
V_{il}	Logic 0 input voltage	-0.3 V	0.8 V	
$V_{ihreset}$	Logic 1 voltage for reset pin (reset)	2.2 V	$V_{cc} + 0.3$ V	

Output Voltages

V_{oh}	Logic 1 Output Voltage	2.4 V		@CP $I_o = -23$ mA @I/O $I_o = -6$ mA
V_{ol}	Logic 0 Output Voltage		0.33 V	@CP $I_o = 6$ mA @I/O $I_o = 6$ mA

Other

I_{out}	Tri-State output leakage current	-5 μ A	5 μ A	@CP $0 < V_{out} < V_{cc}$
I_{in}	Input current	-10 μ A -10 μ A	10 μ A -10 μ A	@CP @I/O $0 < V_i < V_{cc}$
C_{io}	Input/Output capacitance	15 pF	10 pF	@CP typical @I/O

Analog Input

Z_{ai}	Analog input source impedance		9k Ω	
E_{dnl}	Differential nonlinearity error. Difference between the step width and the ideal value.	-1	1.5 LSB	
E_{inl}	Integral nonlinearity error. Maximum deviation from the best straight line through the ADC transfer characteristics, excluding the quantization error.		+/-1.5 LSB	

3.2 AC characteristics

See timing diagrams, Section 4, for T_n numbers. The symbol “~” indicates active low signal.

Timing Interval	T_n	Minimum	Maximum
Clock Frequency (F_{clk})		> 0 MHz	40 MHz (note 1)
Clock Pulse Width	T1	10 nsec	
Clock Period (note 3)	T2	25 nsec	
Encoder Pulse Width	T3	150 nsec	
Dwell Time Per State	T4	75 nsec	

Timing Interval	T _n	Minimum	Maximum
Index Setup and Hold (relative to Quad A and Quad B low)	T5	0 nsec	
~HostSlct Hold Time	T6	0 nsec	
~HostSlct Setup Time	T7	0 nsec	
HostCmd Setup Time	T8	0 nsec	
HostCmd Hold Time	T9	0 nsec	
Read Data Access Time	T10		25 nsec
Read Data Hold Time	T11		10 nsec
~HostRead High to HI-Z Time	T12		20 nsec
HostRdy Delay Time	T13	100 nsec	150 nsec
~HostWrite Pulse Width	T14	70 nsec	
Write Data Delay Time	T15		35 nsec
Write Data Hold Time	T16	0 nsec	
Read Recovery Time (<i>note 2</i>)	T17	60 nsec	
Write Recovery Time (<i>note 2</i>)	T18	60 nsec	
Read Pulse Width	T19	70 nsec	
Address Setup Delay Time	T20		7 nsec
Data Access Time	T21		19 nsec
Data Hold Time	T22		2 nsec
Address Setup Delay Time	T23		7 nsec
Address Setup to WriteEnable High	T24	72 nsec	
RAMSlct Low to WriteEnable High	T25		79 nsec
Address Hold Time	T26	17 nsec	
WriteEnable Pulse Width	T27	39 nsec	
Data Setup Time	T28		3 nsec
Data Setup before Write High Time	T29		42 nsec
Address Setup Delay Time	T30		7 nsec
Data Access Time	T31		71 nsec
Data Hold Time	T32		2 nsec
Address Setup Delay Time	T33		7 nsec
Address Setup to WriteEnable High	T34	122 nsec	
PeriphSlct Low to WriteEnable High	T35		129 nsec
Address Hold Time	T36	17 nsec	
WriteEnable Pulse Width	T37	89 nsec	
Data Setup Time	T38		3 nsec
Data Setup before Write High Time	T39		92 nsec
Read to Write Delay Time	T40	50 nsec	
Reset Low Pulse Width	T50	5.0 μ sec	
RAMSlct Low to Strobe Low	T51		1 nsec
Strobe High to RAMSlct High	T52		4 nsec
WriteEnable Low to Strobe Low	T53		1 nsec
Strobe High to WriteEnable High	T54		3 nsec
PeriphSlct Low to Strobe Low	T55		1 nsec
Strobe High to PeriphSlct High	T56		4 nsec

Note 1 Performance figures and timing information valid at $F_{clk} = 40.0$ MHz only. For timing information and performance parameters at $F_{clk} < 40.0$ MHz see section 6.1.

Note 2 For 8/8 and 8/16 interface modes only.

Note 3 The clock low/high split has an allowable range of 45-55%.

4 I/O Timing Diagrams

For the values of T_n , please refer to the table in Section 3.2.

4.1 Clock

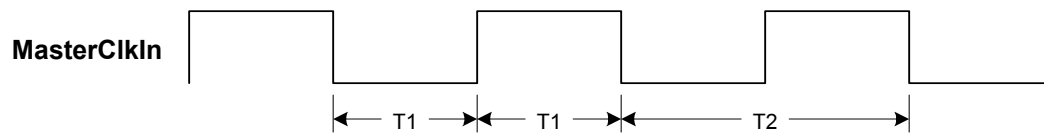

4.2 Quadrature encoder input

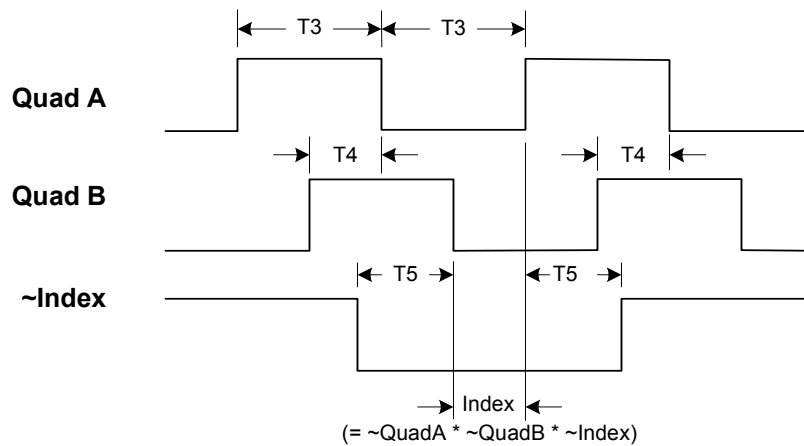

4.3 Reset

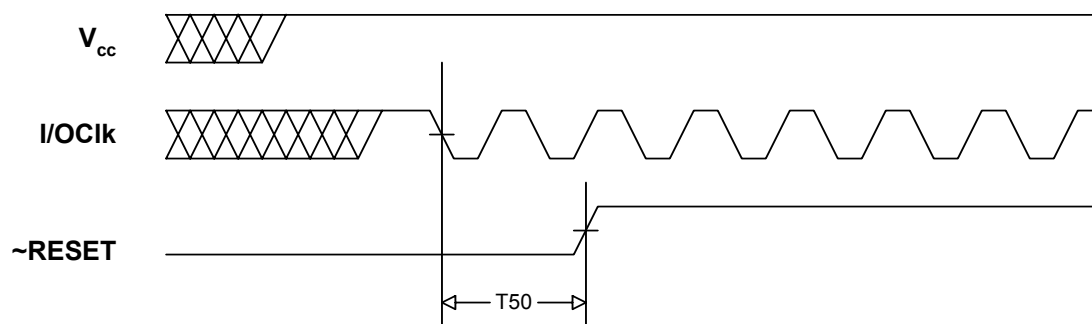

4.4 Host interface, 8/8 mode

4.4.1 Instruction write, 8/8 mode

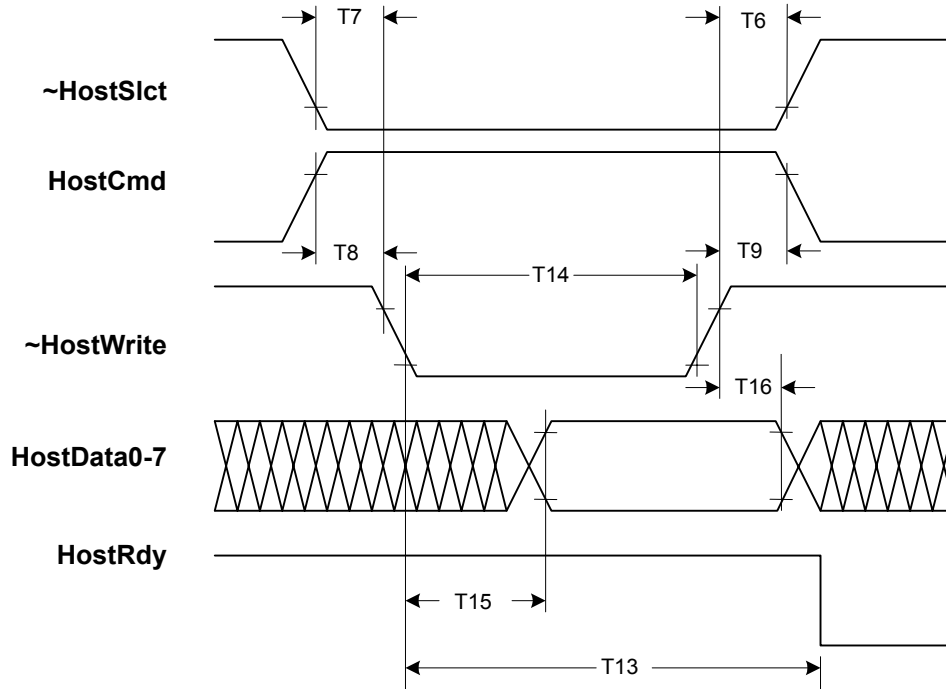

4.4.2 Data write, 8/8 mode

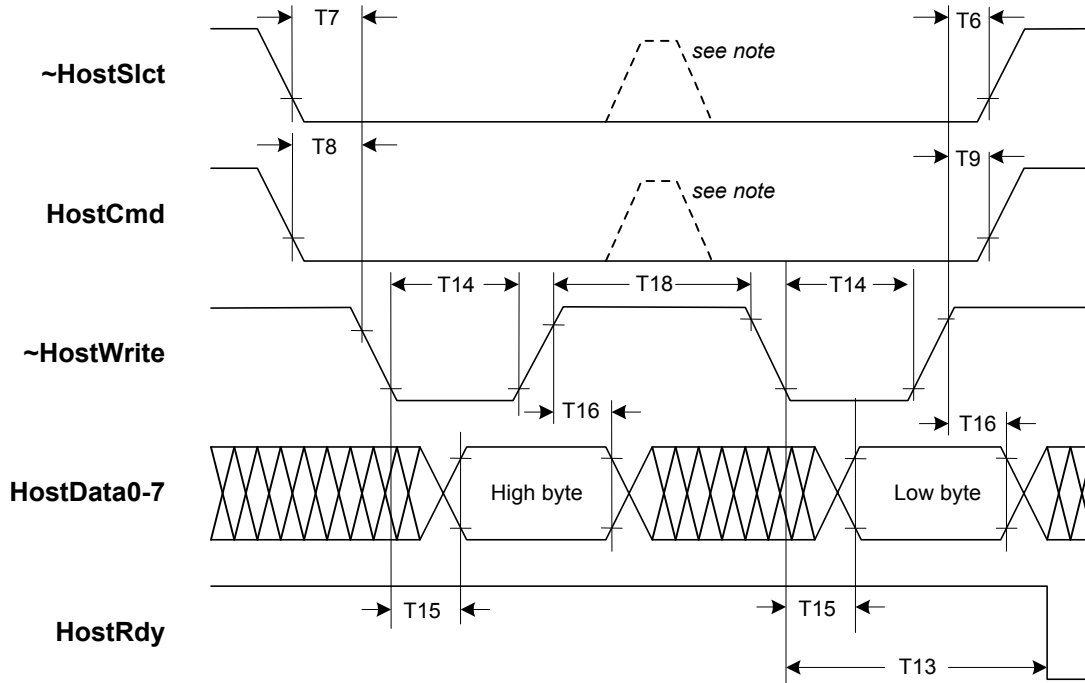

Note: If setup and hold times are met, ~HostSlct and HostCmd may be de-asserted at this point.

4.4.3 Data read, 8/8 mode

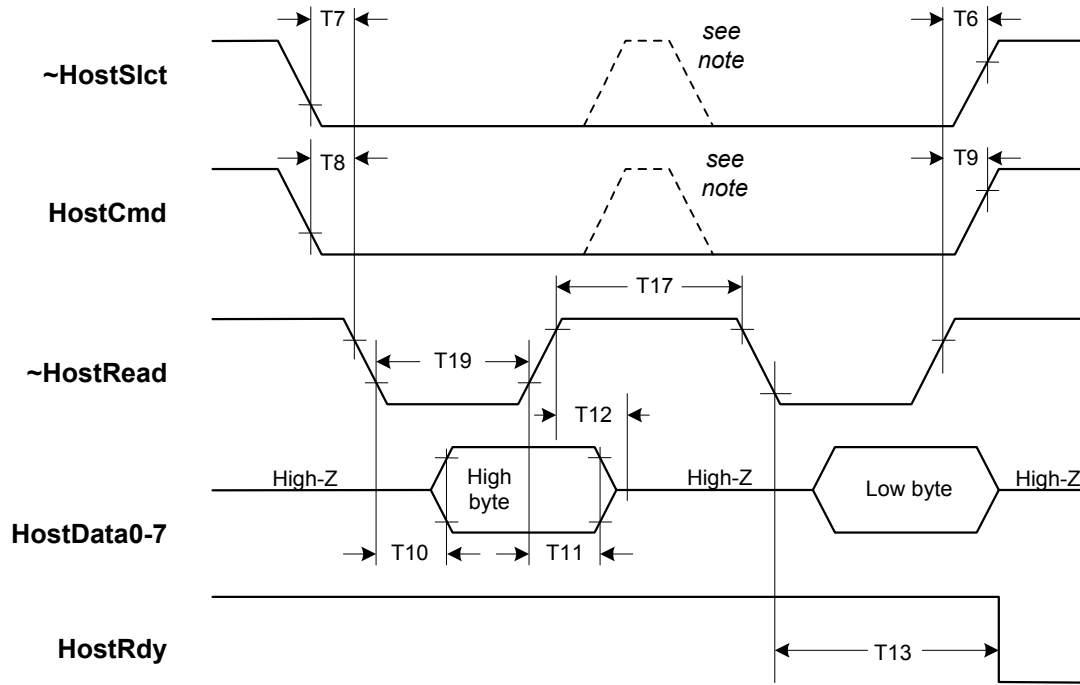

Note: If setup and hold times are met, \sim HostSlct and HostCmd may be de-asserted at this point.

4.4.4 Status read, 8/8 mode

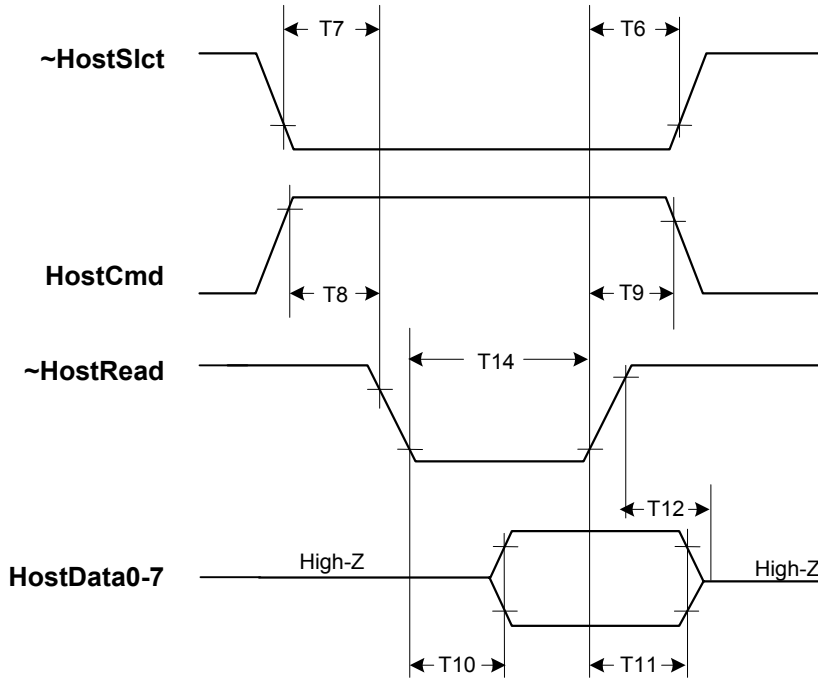

4.5 Host interface, 8/16 mode

4.5.1 Instruction write, 8/16 mode

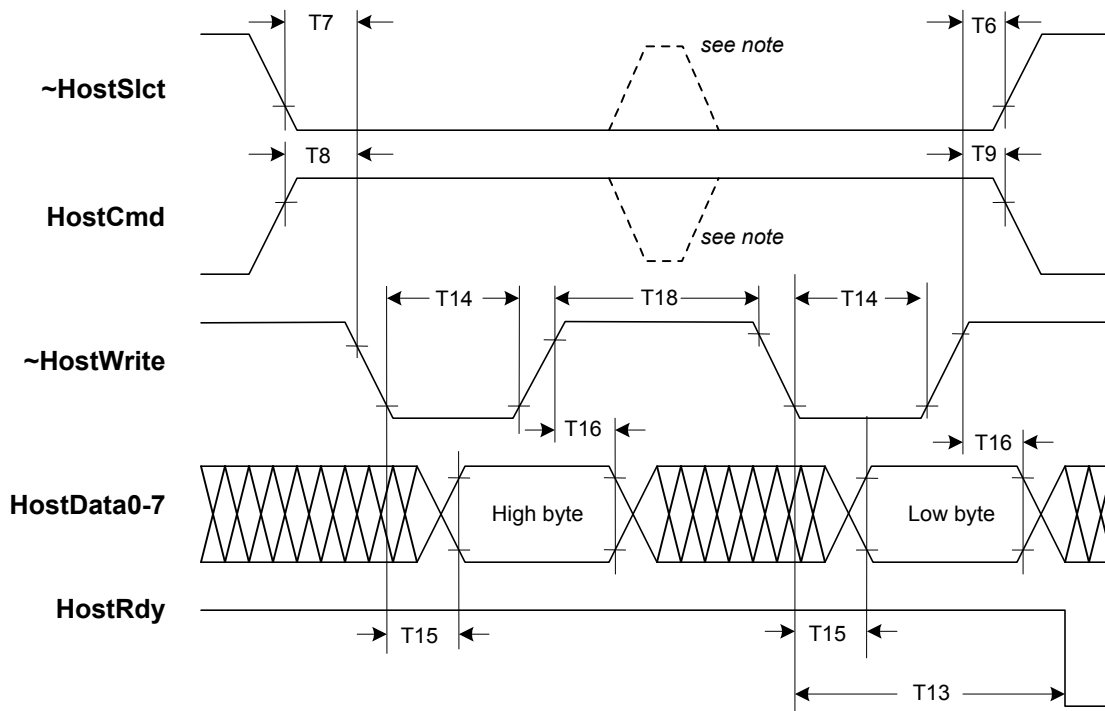

Note: If setup and hold times are met, \sim HostSlct and HostCmd may be de-asserted at this point.

4.5.2 Data write, 8/16 mode

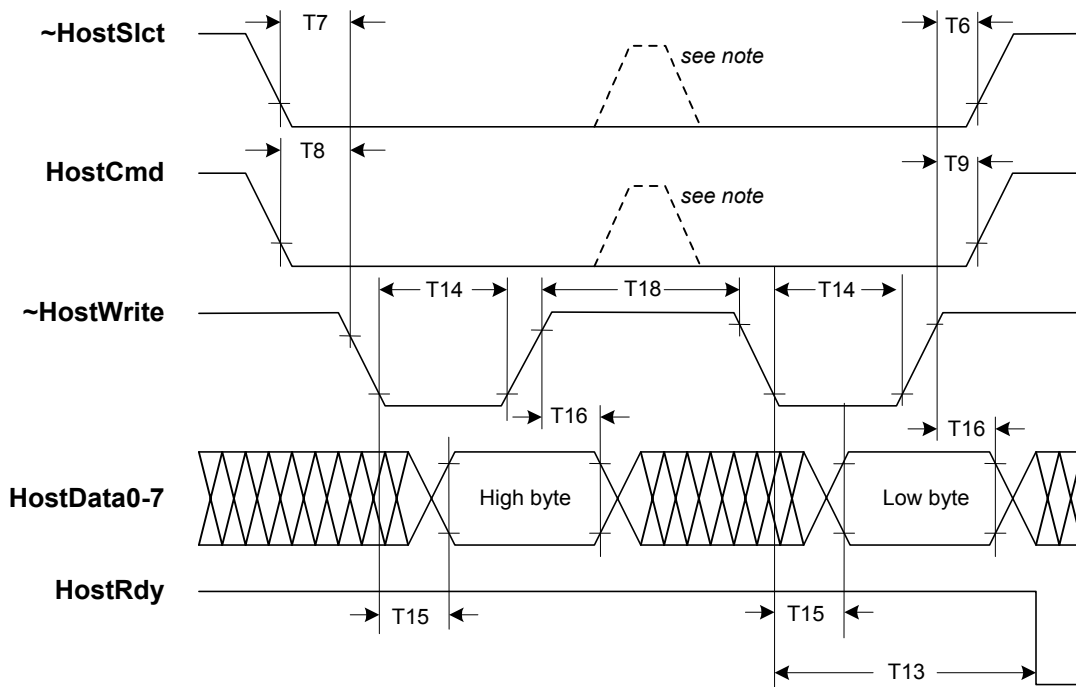

Note: If setup and hold times are met, \sim HostSlct and HostCmd may be de-asserted at this point.

4.5.3 Data read, 8/16 mode

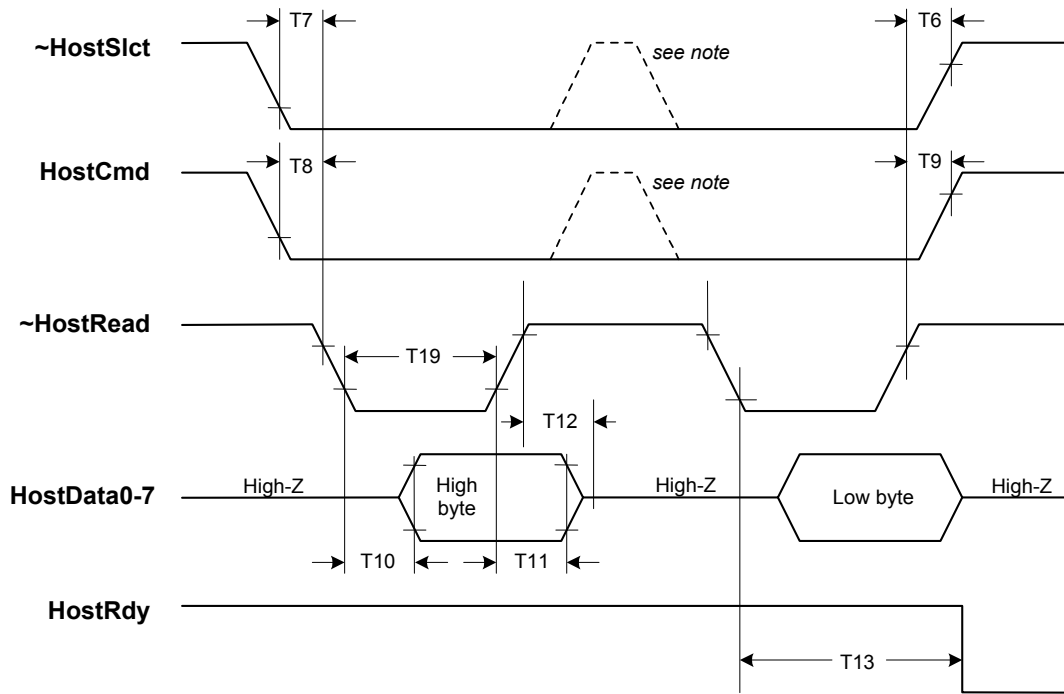

Note: If setup and hold times are met, \sim HostSlct and HostCmd may be de-asserted at this point.

4.5.4 Status read, 8/16 mode

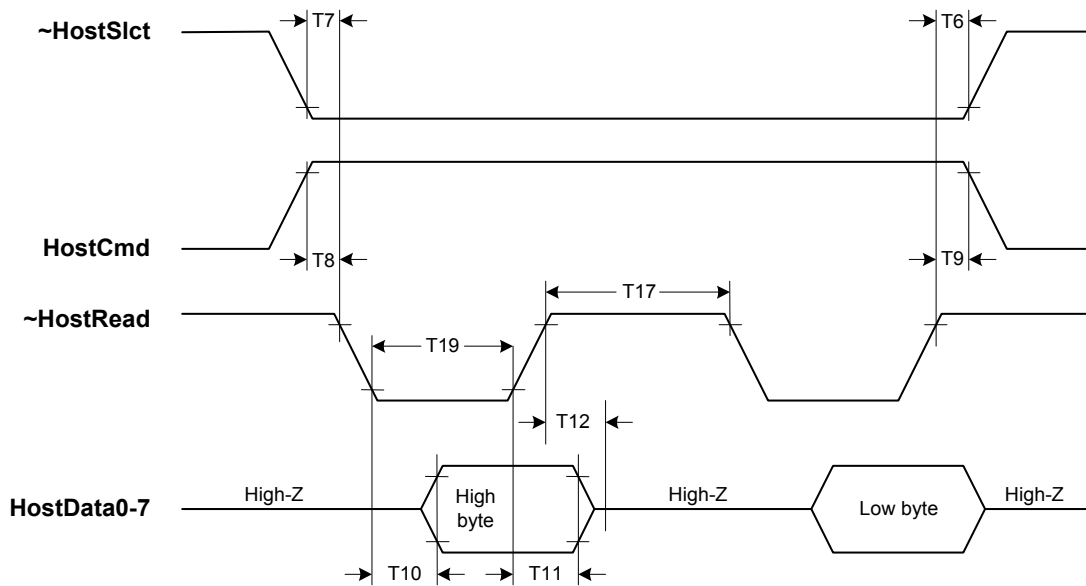

4.6 Host interface, 16/16 mode

4.6.1 Instruction write, 16/16 mode

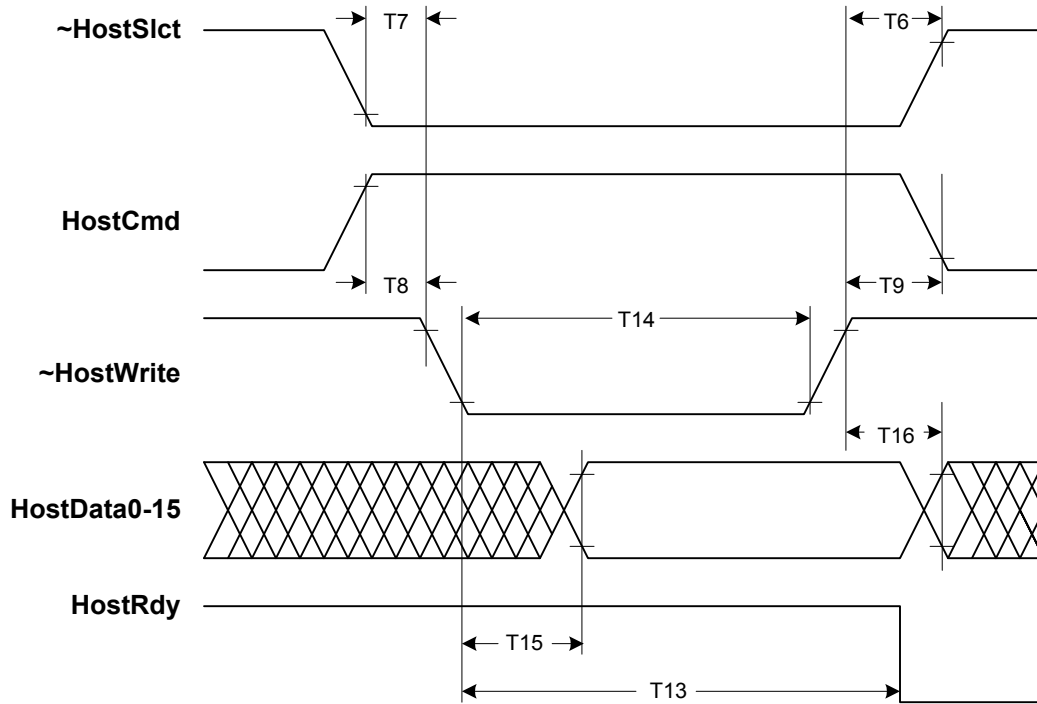

4.6.2 Data write, 16/16 mode

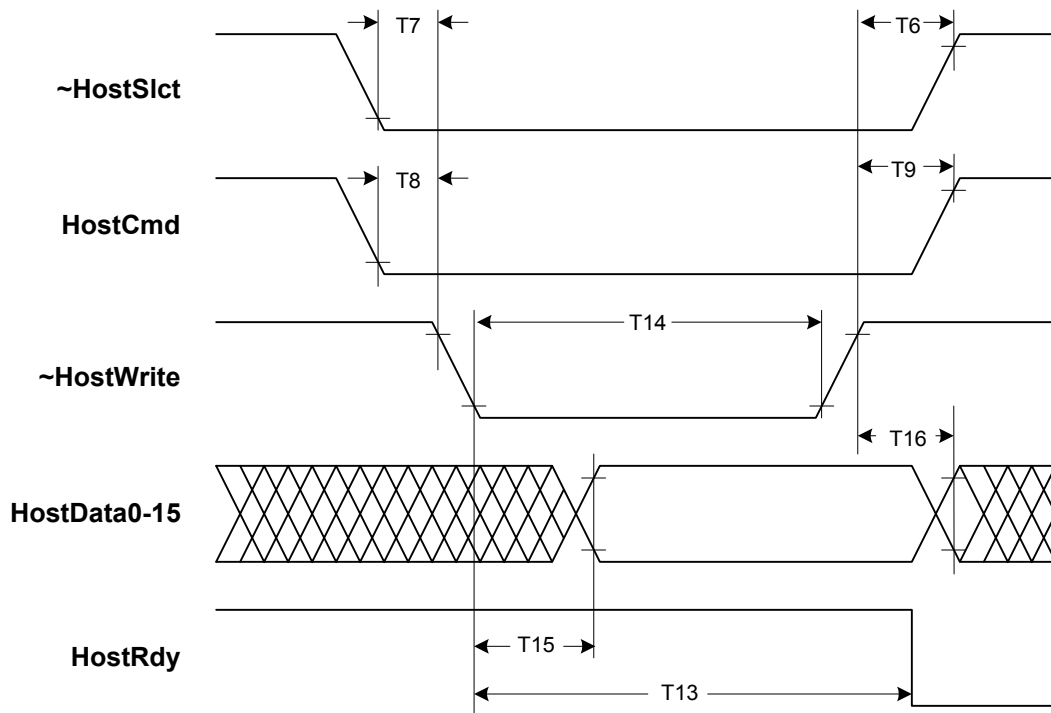

4.6.3 Data read, 16/16 mode

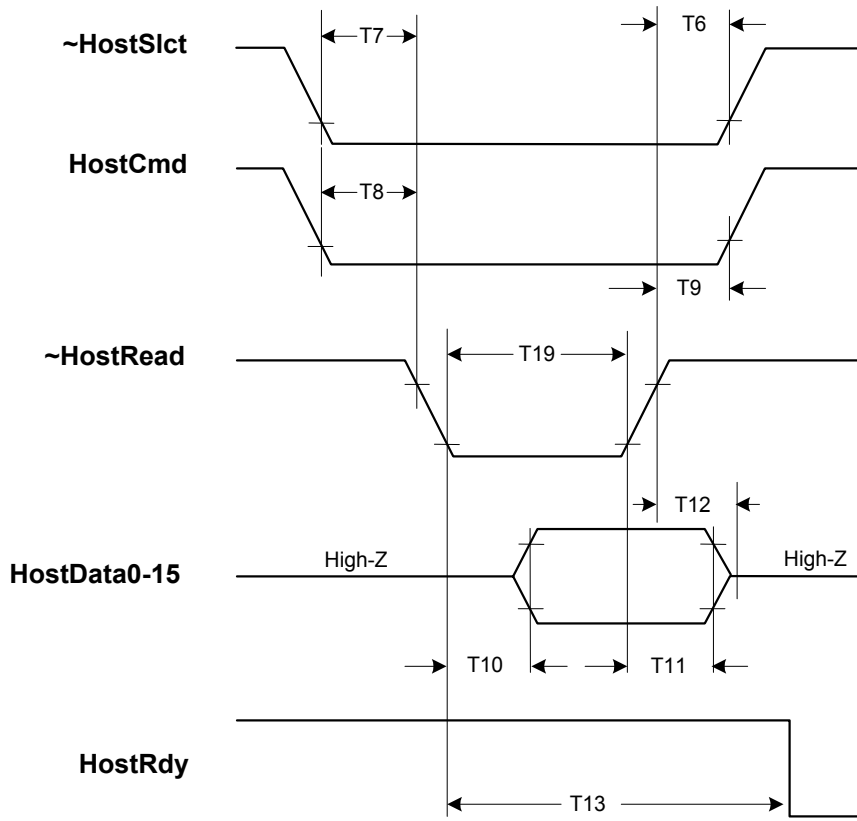

4.6.4 Status read, 16/16 mode

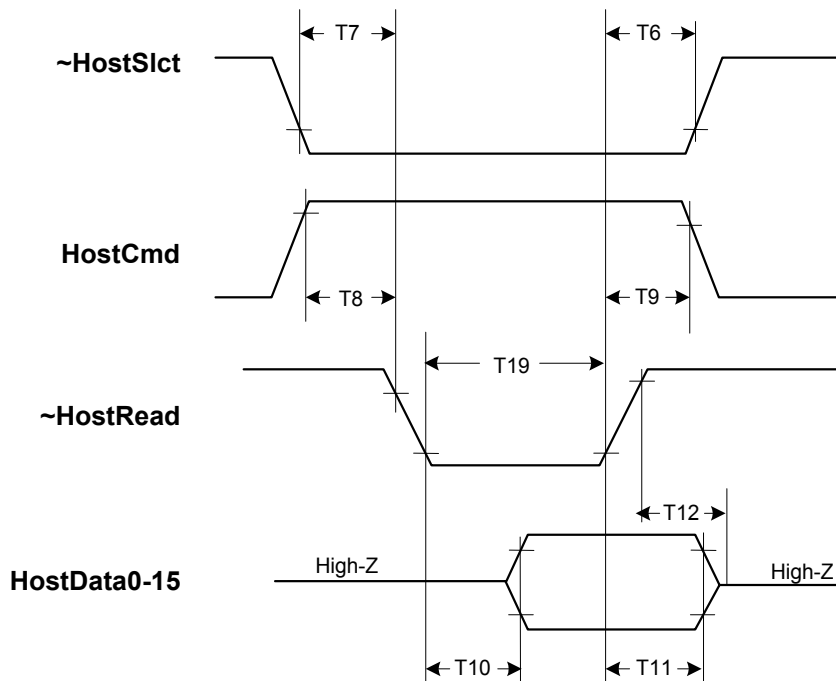

4.7 External memory timing

4.7.1 External memory read

Note: PMD recommends using memory with an access time no greater than 15 nsec.

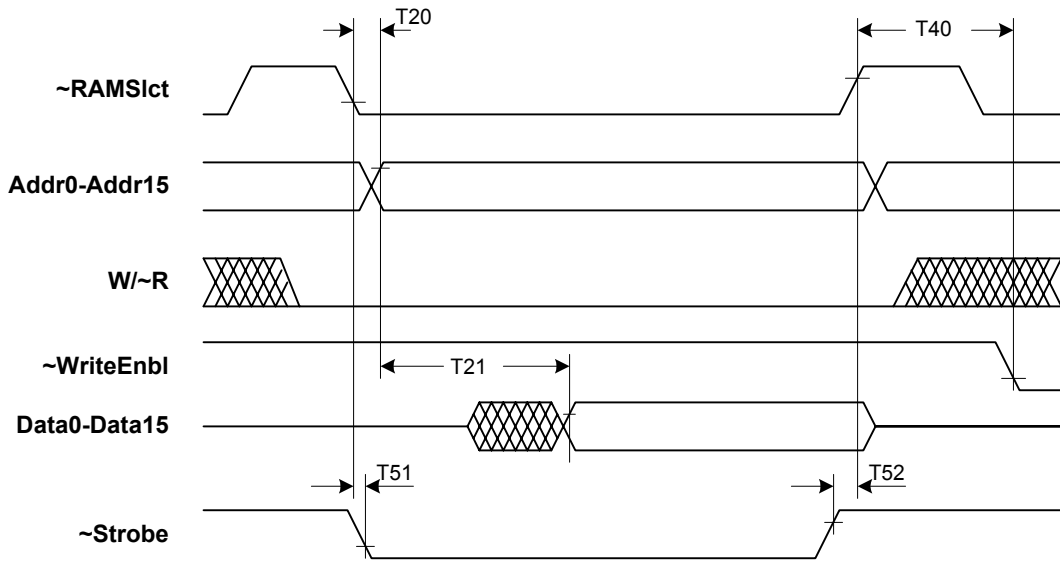

4.7.2 External memory write

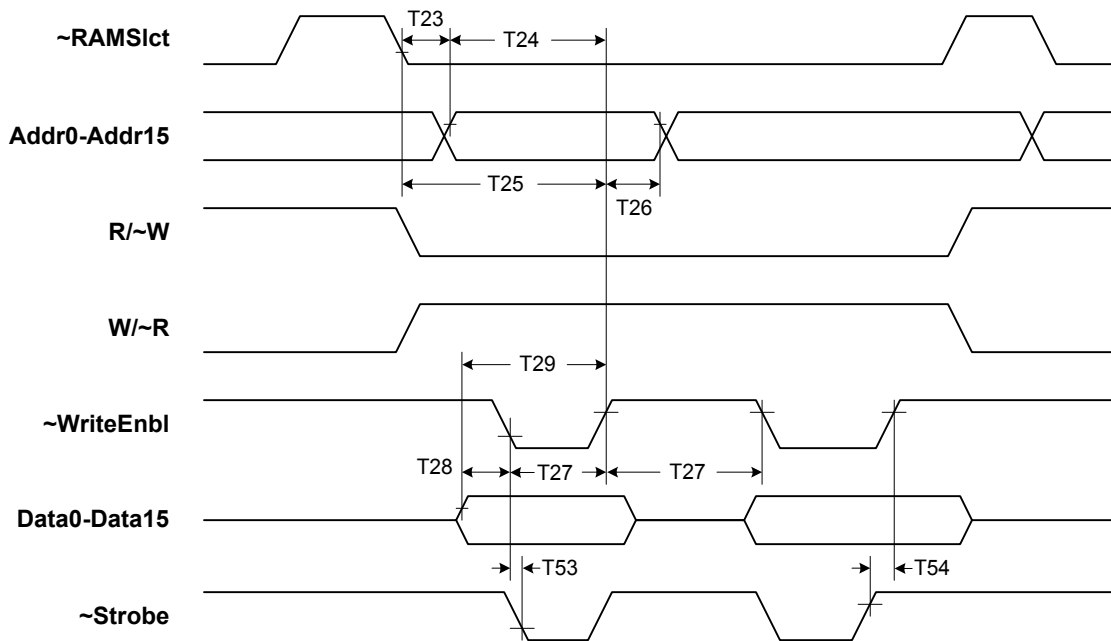

4.8 Peripheral device timing

4.8.1 Peripheral device read

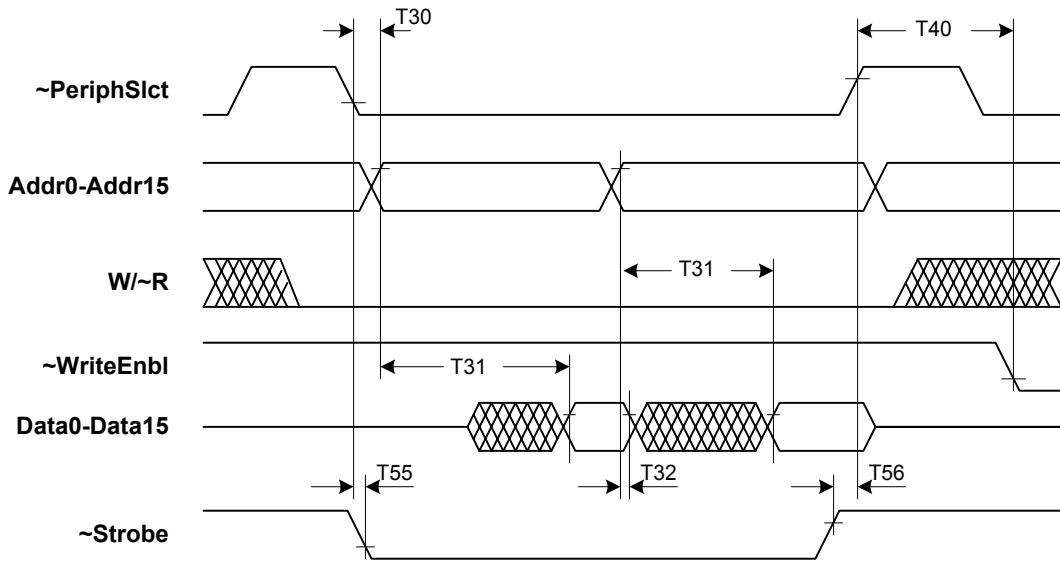

4.8.2 Peripheral device write

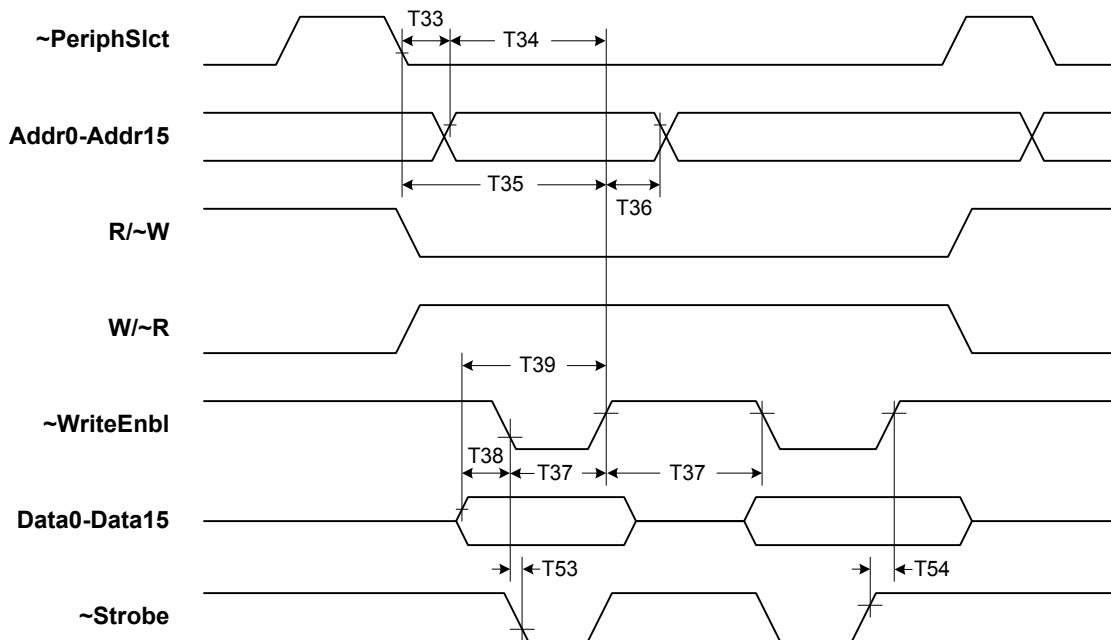

5 Pinouts and Pin Descriptions

5.1 Pinouts for MC2340

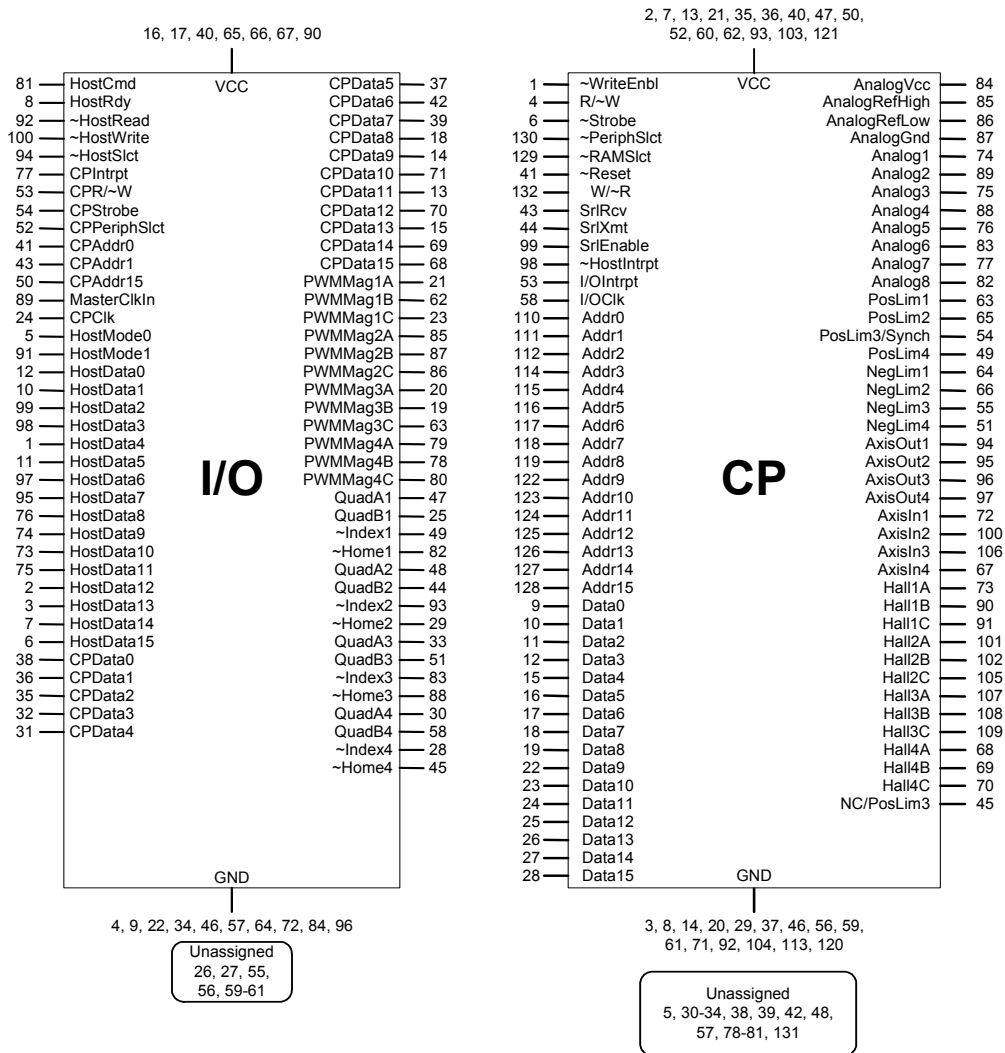

5.2 Pinouts for MC2320

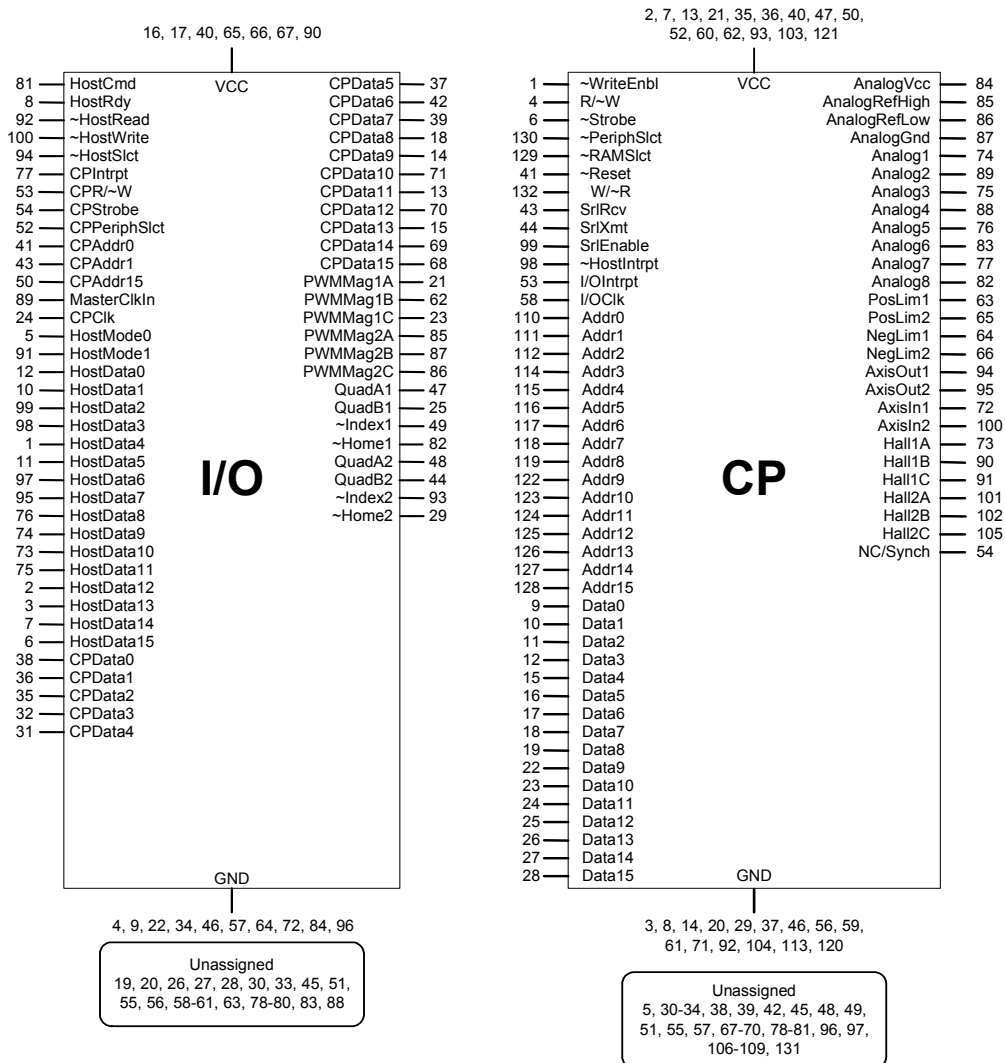

5.3 Pinouts for MC2310

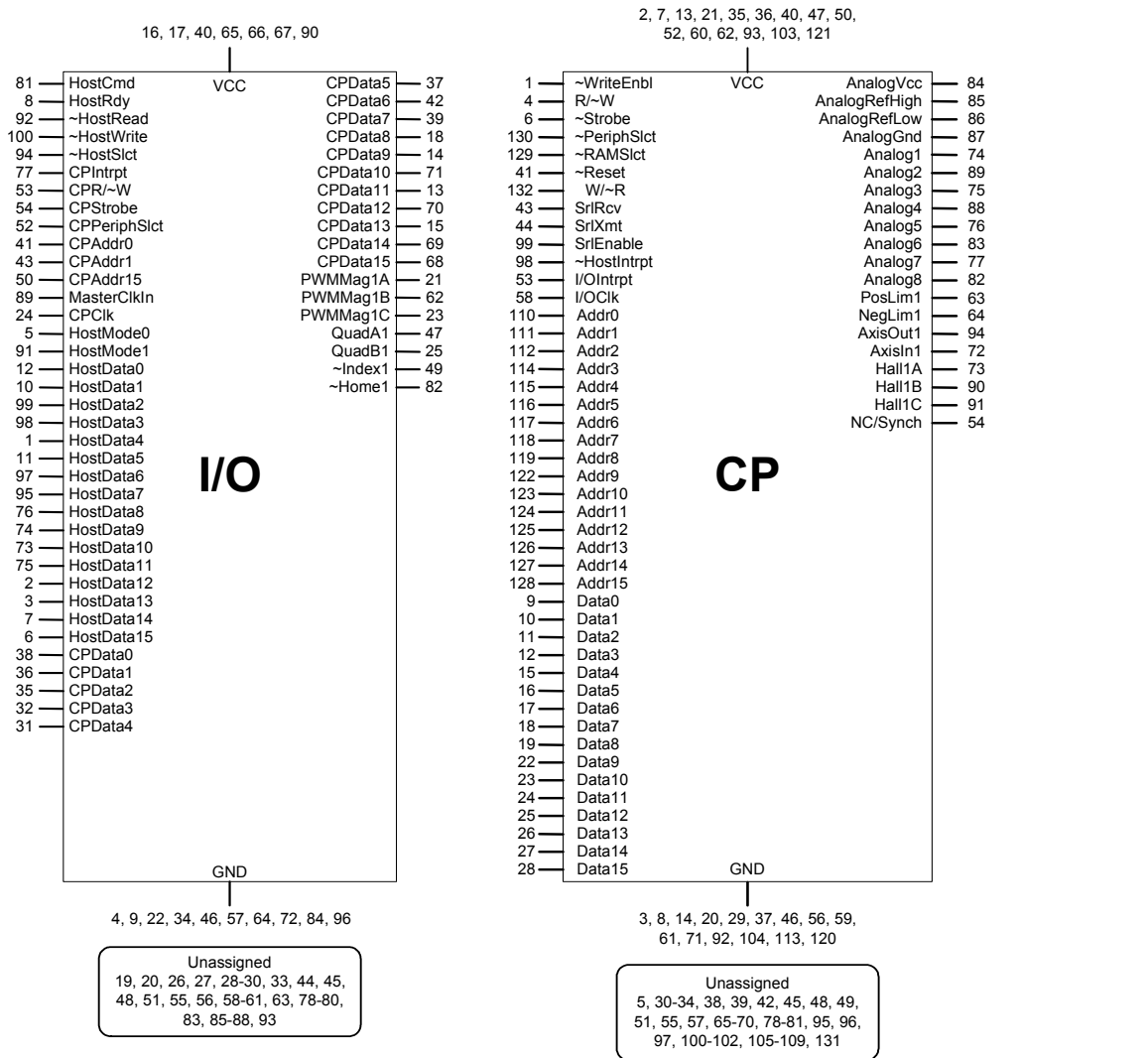

5.4 Pin description tables

5.4.1 I/O chip

I/O Chip			
Pin Name and number		Direction	Description
HostCmd	81	Input	This signal is asserted <i>high</i> to write a host instruction to the Motion Processor, or to read the status of the HostRdy and HostIntrpt signals. It is asserted <i>low</i> to read or write a data word.
HostRdy	8	Output	This signal is used to synchronize communication between the Motion Processor and the host. HostRdy will go <i>low</i> (indicating host port busy) at the end of a read or write operation according to the interface mode in use, as follows: Interface Mode HostRdy goes low 8/8 after the instruction byte is transferred after the second byte of each data word is transferred 8/16 after the second byte of the instruction word after the second byte of each data word is transferred 16/16 after the 16-bit instruction word after each 16-bit data word serial <i>n/a</i> HostRdy will go <i>high</i> , indicating that the host port is ready to transmit, when the last transmission has been processed. All host port communications must be made with HostRdy <i>high</i> (ready). A typical busy-to-ready cycle is 12.5 microseconds.
~HostRead	92	Input	When ~HostRead is <i>low</i> , a data word is read from the Motion Processor.
~HostWrite	100	Input	When ~HostWrite is <i>low</i> , a data word is written to the Motion Processor.
~HostSlct	94	Input	When ~HostSlct is <i>low</i> , the host port is selected for reading or writing operations.
CPIntrpt	77	Output	I/O chip to CP chip interrupt. This signal sends an interrupt to the CP chip whenever a host–chipset transmission occurs. It should be connected to CP chip pin 53, I/OIntrpt .
CPR/~W	53	Input	This signal is <i>high</i> when the I/O chip is reading data from the I/O chip, and <i>low</i> when it is writing data. It should be connected to CP chip pin 4, R/W .
CPStrobe	54	Input	This signal goes <i>low</i> when the data and address become valid during Motion Processor communication with peripheral devices on the data bus, such as external memory or a DAC. It should be connected to CP chip pin 6, Strobe .
CPPeriphSlct	52	Input	This signal goes <i>low</i> when a peripheral device on the data bus is being addressed. It should be connected to CP chip pin 130, PeriphSlct .
CPAddr0 CPAddr1 CPAddr15	41 43 50	Input	These signals are <i>high</i> when the CP chip is communicating with the I/O chip (as distinguished from any other device on the data bus). They should be connected to CP chip pins 110 (Addr0), 111 (Addr1), and 128 (Addr15).
MasterClkIn	89	Input	This is the master clock signal for the Motion Processor. It is driven at a nominal 40 MHz
CPClk	24	Output	This signal provides the clock pulse for the CP chip. Its frequency is half that of MasterClkIn (pin 89), or 20 MHz nominal. It is connected directly to the CP chip I/Oclk signal (pin 58).

I/O Chip

Pin Name and number		Direction	Description															
HostMode1	91	Input	<p>These two signals determine the host communications mode, as follows:</p> <table border="0"> <thead> <tr> <th style="text-align: left;">HostMode1</th> <th style="text-align: left;">HostMode0</th> <th></th> </tr> </thead> <tbody> <tr> <td>0</td> <td>0</td> <td>16/16 parallel (16-bit bus, 16-bit instruction)</td> </tr> <tr> <td>0</td> <td>1</td> <td>8/8 parallel (8-bit bus, 8-bit instruction)</td> </tr> <tr> <td>1</td> <td>0</td> <td>8/16 parallel (8-bit bus, 16-bit instruction)</td> </tr> <tr> <td>1</td> <td>1</td> <td>serial</td> </tr> </tbody> </table>	HostMode1	HostMode0		0	0	16/16 parallel (16-bit bus, 16-bit instruction)	0	1	8/8 parallel (8-bit bus, 8-bit instruction)	1	0	8/16 parallel (8-bit bus, 16-bit instruction)	1	1	serial
HostMode1	HostMode0																	
0	0	16/16 parallel (16-bit bus, 16-bit instruction)																
0	1	8/8 parallel (8-bit bus, 8-bit instruction)																
1	0	8/16 parallel (8-bit bus, 16-bit instruction)																
1	1	serial																
HostMode0	5																	
HostData0	12	Bi-directional, tri-state	<p>These signals transmit data between the host and the Motion Processor through the parallel port. Transmission is mediated by the control signals \simHostSlct, \simHostWrite, \simHostRead and HostCmd.</p> <p>In 16 bit mode all 16 bits are used (HostData0-15). In 8 bit mode only the low-order 8 bits of data are used (HostData0-7). The HostMode0 and HostMode1 signals select the communication mode this port operates in.</p>															
HostData1	10																	
HostData2	99																	
HostData3	98																	
HostData4	1																	
HostData5	11																	
HostData6	97																	
HostData7	95																	
HostData8	76																	
HostData9	74																	
HostData10	73																	
HostData11	75																	
HostData12	2																	
HostData13	3																	
HostData14	7																	
HostData15	6																	
CPData0	38	Bi-directional	<p>These signals transmit data between the I/O chip and pins Data0-15 of the CP chip, via the Motion Processor data bus.</p>															
CPData1	36																	
CPData2	35																	
CPData3	32																	
CPData4	31																	
CPData5	37																	
CPData6	42																	
CPData7	39																	
CPData8	18																	
CPData9	14																	
CPData10	71																	
CPData11	13																	
CPData12	70																	
CPData13	15																	
CPData14	69																	
CPData15	68																	
PWMMag1A	21	Output	<p>These pins provide the Pulse Width Modulated signals for each phase to the motor.</p> <p>In PWM 50/50 output mode the sign (direction) is encoded within each signal. Refer to the User's Guide for more information.</p> <p>The PWM resolution is 10 bits at a frequency of 20.0 KHz.</p> <p>For MC2340 all pins are valid. For MC2320 only PWMMag1A-C and PWMMag2A-C are valid. For MC2310 only PWMMag1A-C is valid.</p> <p>Invalid or unused pins may be left unconnected.</p>															
PWMMag1B	62																	
PWMMag1C	23																	
PWMMag2A	85																	
PWMMag2B	87																	
PWMMag2C	86																	
PWMMag3A	20																	
PWMMag3B	19																	
PWMMag3C	63																	
PWMMag4A	79																	
PWMMag4B	78																	
PWMMag4C	80																	

I/O Chip

Pin Name and number	Direction	Description
QuadA1 QuadB1 QuadA2 QuadB2 QuadA3 QuadB3 QuadA4 QuadB4	47 25 48 44 33 51 30 58	Input These pins provide the A and B quadrature signals for the incremental encoder for each axis. When the axis is moving in the positive (forward) direction, signal A leads signal B by 90°. The theoretical maximum encoder pulse rate is 5.1 MHz. Actual maximum rate will vary, depending on signal noise. NOTE: Many encoders require a pull-up resistor on each signal to establish a proper high signal. Check your encoder's electrical specifications). For MC2340 all 8 pins are valid. For MC2320 only the first four pins (axes 1 and 2) are valid. <hr/> WARNING! If a valid axis pin is not used, its signal must be tied high. <hr/> Invalid axis pins may be left unconnected.
~Index1 ~Index2 ~Index3 ~Index4	49 93 83 28	Input These pins provide the Index quadrature signals for the incremental encoders. A valid index pulse is recognized by the chip set when ~Index, A, and B are all <i>low</i> . For MC2340 all 4 pins are valid. For MC2320 only ~Index1 and ~Index2 are valid. For MC2310 only ~Index1 is valid. <hr/> WARNING! If a valid axis pin is not used, its signal must be tied high. <hr/> Invalid axis pins may be left unconnected.
~Home1 ~Home2 ~Home3 ~Home4	82 29 88 45	Input These pins provide the Home signals, general-purpose inputs to the position-capture mechanism. A valid Home signal is recognized by the chipset when ~Home _n goes <i>low</i> . These signals are similar to ~Index, but are not gated by the A and B encoder channels. For MC2340 all 4 pins are valid. For MC2320 only ~Home1 and ~Home2 are valid. For MC2310 only ~Home1 is valid. <hr/> WARNING! If a valid axis pin is not used, its signal must be tied high. <hr/> Invalid axis pins may be left unconnected.
Vcc	16, 17, 40, 65, 66, 67, 90	All of these pins must be connected to the I/O chip's digital supply voltage, which should be in the range 4.75 to 5.25 V.
GND	4, 9, 22, 34, 46, 57, 64, 72, 84, 96	I/O chip ground. All of these pins must be connected to the digital power supply return.
unassigned	26, 27, 55, 56, 59-61,	These pins may be left unconnected (floating).

5.4.2 CP chip

CP chip

Pin Name and number	Direction	Description	
~WriteEnbl	1	output	When <i>low</i> , this signal enables data to be written to the bus.
R/~W	4	output	This signal is <i>high</i> when the CP chip is performing a read, and <i>low</i> when it is performing a write. It should be connected to I/O chip pin 53, CPR/~W .
~Strobe	6	output	This signal is <i>low</i> when the data and address are valid during CP communications. It should be connected to I/O chip pin 54, CPStrobe .
~PeriphSlct	130	output	This signal is <i>low</i> when peripheral devices on the data bus are being addressed. It should be connected to I/O chip pin 52, CPPeriphSlct .
~RAMSlct	129	output	This signal is <i>low</i> indicates when external memory is being accessed.
~Reset	41	input	This is the master reset signal. When brought <i>low</i> , this pin resets the chipset to its initial conditions.
W/~R	132	output	This signal is the inverse of R/~W; it is <i>high</i> when R/~W is low, and vice versa. For some decode circuits this is more convenient than R/~W.
SrlRcv	43	input	This pin receives serial data from the asynchronous serial port.
SrlXmt	44	output	This pin transmits serial data to the asynchronous serial port.
SrlEnable	99	output	This pin sets the serial port enable line. SrlEnable is always <i>high</i> for the point-to-point protocol and is <i>high</i> during transmission for the multi-drop protocol.
~HostIntrpt	98	output	When <i>low</i> , this signal causes an interrupt to be sent to the host processor.
I/OIntrpt	53	input	This signal interrupts the CP chip when a host I/O transfer is complete. It should be connected to I/O chip pin 77, CPIntrpt .
Data0 Data1 Data2 Data3 Data4 Data5 Data6 Data7 Data8 Data9 Data10 Data11 Data12 Data13 Data14 Data15	9 10 11 12 15 16 17 18 19 22 23 24 25 26 27 28	Bi-directional	Multi-purpose data lines. These pins comprise the CP chip's external data bus, used for all communications with the I/O chip and peripheral devices such as external memory or DACs. They may also be used for parallel-word input and for user-defined I/O operations.
Addr0 Addr1 Addr2 Addr3 Addr4 Addr5 Addr6 Addr7 Addr8 Addr9 Addr10 Addr11 Addr12 Addr13 Addr14 Addr15	110 111 112 114 115 116 117 118 119 122 123 124 125 126 127 128	output	Multi-purpose Address lines. These pins comprise the CP chip's external address bus, used to select devices for communication over the data bus. Addr0, Addr1, and Addr15 are connected to the corresponding CPAddr pins on the I/O chip, and are used to communicate between the CP and I/O chips. Other address pins may be used for DAC output, parallel word input, or user-defined I/O operations. See the <i>Navigator Motion Processor User's Guide</i> for a complete memory map.

CP chip

Pin Name and number	Direction	Description
I/OClk	58	input This is the CP chip clock signal. It should be connected to I/O chip pin 24, CPClk.
AnalogVcc	84	input CP chip analog power supply voltage. This pin must be connected to the analog input supply voltage, which must be in the range 4.5-5.5 V If the analog input circuitry is not used, this pin may be left unconnected.
AnalogRefHigh	85	input CP chip analog high voltage reference for A/D input. The allowed range is AnalogRefLow to AnalogVcc . If the analog input circuitry is not used, this pin may be left unconnected.
AnalogRefLow	86	input CP chip analog low voltage reference for A/D input. The allowed range is AnalogGND to AnalogRefHigh . If the analog input circuitry is not used, this pin may be left unconnected.
AnalogGND	87	CP chip analog input ground. This pin must be connected to the analog input power supply return. If the analog input circuitry is not used, this pin may be left unconnected.
Analog1 Analog2 Analog3 Analog4 Analog5 Analog6 Analog7 Analog8	74 89 75 88 76 83 77 82	input These signals provide general-purpose analog voltage levels which are sampled by an internal A/D converter. The A/D resolution is 10 bits. The allowed range is AnalogRefLow to AnalogRefHigh .
PosLim1 PosLim2 PosLim4	63 65 49	input These signals provide inputs from the positive-side (forward) travel limit switches. On power-up or Reset these signals default to active <i>low</i> interpretation, but the interpretation can be set explicitly using the SetSignalSense instruction. For MC2340 all 4 pins are valid. For MC2320 only PosLim1 and PosLim2 are valid. For MC2310 only PosLim1 is valid. <hr/> WARNING! If a valid axis pin is not used, its signal must be tied high. <hr/> Invalid axis pins may also be left unconnected.
PosLim3/ Synch	54	input/output On the MC2340 chipset, this pin is the positive-side (forward) travel limit switch for axis#3. On the MC2320 and MC2310 chipsets this pin is not used. On the MC23x3 chipset, this pin is the synchronization signal. In the disabled mode, the pin is configured as an input and is not used. In the master mode, the pin outputs a synchronization pulse that can be used by slave nodes or other devices to synchronize with the internal chip cycle of the master node. In the slave mode, the pin is configured as an input and a pulse on the pin synchronizes the internal chip cycle. <hr/> WARNING! If a valid axis limit pin is not used, its signal should be tied high. <hr/>
NC/PosLim3	45	input On the MC23x0 chipset, this pin is not used. On the MC2343 chipset, this pin is the positive-side (forward) travel limit switch for axis#3. On the MC2323 and MC2313 chipsets this pin is not used. <hr/> WARNING! If a valid axis limit pin is not used, its signal should be tied high. <hr/>

CP chip

Pin Name and number	Direction	Description
NegLim1 NegLim2 NegLim3 NegLim4	64 66 55 51	input
<p>These signals provide inputs from the negative-side (reverse) travel limit switches. On power-up or Reset these signals default to active <i>low</i> interpretation, but the interpretation can be set explicitly using the SetSignalSense instruction. For MC2340 all 4 pins are valid. For MC2320 only NegLim1 and NegLim2 are valid. For MC2310 only NegLim1 is valid.</p> <hr/> <p>WARNING! If a valid axis pin is not used, its signal must be tied high.</p> <hr/> <p>Invalid axis pins may also be left unconnected.</p>		
AxisOut1 AxisOut2 AxisOut3 AxisOut4	94 95 96 97	output
<p>Each of these pins can be conditioned to track the state of any bit in the Status registers associated with its axis. For MC2340 all 4 pins are valid. For MC2320 only AxisOut1 and AxisOut2 are valid. For MC2310 only AxisOut1 is valid. Invalid or unused pins may be left unconnected.</p>		
AxisIn1 AxisIn2 AxisIn3 AxisIn4	72 100 106 67	input
<p>These are general-purpose programmable inputs. They may be used as a breakpoint input, to stop a motion axis, or to cause an UPDATE to occur. For MC2340 all 4 pins are valid. For MC2320 only AxisIn1 and AxisIn2 are valid. For MC2310 only AxisIn1 is valid. Invalid or unused pins may be left unconnected.</p>		
Hall1A Hall1B Hall1C Hall2A Hall2B Hall2C Hall3A Hall3B Hall3C Hall4A Hall4B Hall4C	73 90 91 101 102 105 107 108 109 68 69 70	Input
<p>Hall sensor inputs. Each set (A, B, and C) of signals encodes 6 valid states as follows: A on, A and B on, B on, B and C on, C on, C and A on. A sensor is defined as being on when its signal is <i>high</i>. Note: These signals should only be connected to Hall sensors that are mounted at a 120° offset. Schemes which provide Hall signals 60° apart will not work. For MC2340 all 12 pins are valid. For MC2320 only the first six pins (axes 1 and 2) are valid. For MC2310 only the first three pins (axis 1) are valid. Invalid or unused pins may be left unconnected.</p>		
V _{cc}	2, 7, 13, 21, 35, 36, 40, 47, 50, 52, 60, 62, 93, 103, 121	CP digital supply voltage. All of these pins must be connected to the supply voltage. V _{cc} must be in the range 4.75 - 5.25 V.
<hr/> <p>WARNING! Pin 35 must be tied HIGH with a pull-up resistor. A nominal value of 22K Ohms is suggested.</p> <hr/>		
GND	3, 8, 14, 20, 29, 37, 46, 56, 59, 61, 71, 92, 104, 113, 120	CP ground. All of these pins must be connected to the power supply return.
Unassigned (MC2340)	5, 30-34, 38, 39, 42, 48, 57, 78-81, 131	These signals may be left unconnected (floating).

6 Application Notes

6.1 Design Tips

The following are recommendations for the design of circuits that utilize a PMD Motion Processor.

Serial Interface

The serial interface is a convenient interface that can be used before host software has been written to communicate through the parallel interface. It is recommended that even if the serial interface is not utilized as a standard communication interface, that the serial receive and transmit signals are brought to test points so that they may be connected during initial board configuration/debugging. This is especially important during the prototype phase. The serial receive line should include a pull-up resistor to avoid spurious interrupts when it is not connected to a transceiver.

If the serial configuration decode logic is not implemented (see section 6.3) and the serial interface may be used for debugging as mentioned above, the CP data bus should be tied high. This places the serial interface in a default configuration of 9600,n,8,1 after power on or reset.

Controlling PWM output during reset

When the motion processor is in a reset state (when the reset line is held low) or immediately after a power on, the PWM outputs can be in an unknown state, causing undesirable motor movement. It is recommended that the enable line of any motor amplifier be held in a disabled state by the host processor or some logic circuitry until communication to the motion processor is established. This can be in the form of a delay circuit on the amplifier enable line after power up, or the enable line can be ANDed with the CP reset line.

Reducing noise and power consumption

To reduce the emission of electrical noise and reduce power consumption (caused by floating inputs), all unused input signals can be tied through a resistor to Vcc or directly to GND. The following CP pins can be tied if not used: 45, 48, 68-70, 73, 90, 91, 101, 102, 105, 107-109, 78-81.

Parallel word encoder input

When using parallel word input for motor position, it is useful to also decode this information into the User I/O space. This allows the current input value to be read using the chip instruction ReadIO for diagnostic purposes.

Using a non standard system clock frequency

It is often desirable to share a common clock among several components in a design. In the case of the PMD Motion Processors it is possible to use a clock below the standard value of 40MHz. In this case all system frequencies will be reduced as a fraction of the input clock versus the standard 40MHz clock. The list below shows the affected system parameters:-

- Serial baud rate
- PWM carrier frequency
- Timing characteristics as shown in section 3.2
- Cycle time
- Commutation rate

For example, if an input clock of 34MHz is used with a serial baud rate of 9600 the following timing changes will result:-

- Serial baud rate decreases to $9600 \text{ bps} * 34/40 = 8160 \text{ bps}$
- PWM frequency decreases to $20 \text{ KHz} * 34/40 = 17 \text{ KHz}$
- Cycle time per axis increases to $153.6 \text{ } \mu\text{sec} * 40/34 = 180.71 \text{ } \mu\text{sec}$
- Commutation rate for MC2310/MC2320 decreases to $20\text{KHz} * 34/40 = 17 \text{ KHz}$
- Commutation rate for MC2340 decreases to $10\text{KHz} * 34/40 = 8.5 \text{ KHz}$

6.2 ISA Bus Interface

A complete, ready-to-use ISA (PC/AT) bus interface circuit has been provided to illustrate Navigator host interfacing, as well as to make it easier for the customer to build a Navigator development system.

The interface between the PMD Navigator chipset and the ISA (PC-AT) bus is shown on the following page.

Comments on Schematic

This interface uses a CPLD and two 74LS245s to buffer the data lines. This interface assumes a base address is assigned in the address space of A9-A0, 300-400 hex. These addresses are generally available for prototyping and other system-specific uses without interfering with system assignments. This interface occupies 16 addresses from XX0 to XXF hex though it does not use all the addresses. Four select lines are provided allowing the base address to be set from 300 to 3F0 hex for the select lines SW1-SW4 equal to 0- F respectively. The address assignments used are as follows, where BADR is the base address, 340 hex for example:

Address	use
340h	read-write data
342h	write command -read status
344h	write command -read status
348h	write reset [Data = don't care]

The base address (BADR) is decoded in the 74LS688. It is combined with SA1, SA2, and SA3, (BADR+0,2,4) to form HSELN to select the I/O chip and the 245's. (BADR+2,4) asserts HCMD.

Two addresses are used to be compatible with the first generation products, which used BADR+2 to write command and BADR+4 to read status.

B+8 and IOW* generate a reset pulse, -RS, for the CP chip. The reset instruction is OR'd with RESET on the bus to initialize the PMD chipset when the PC is reset.

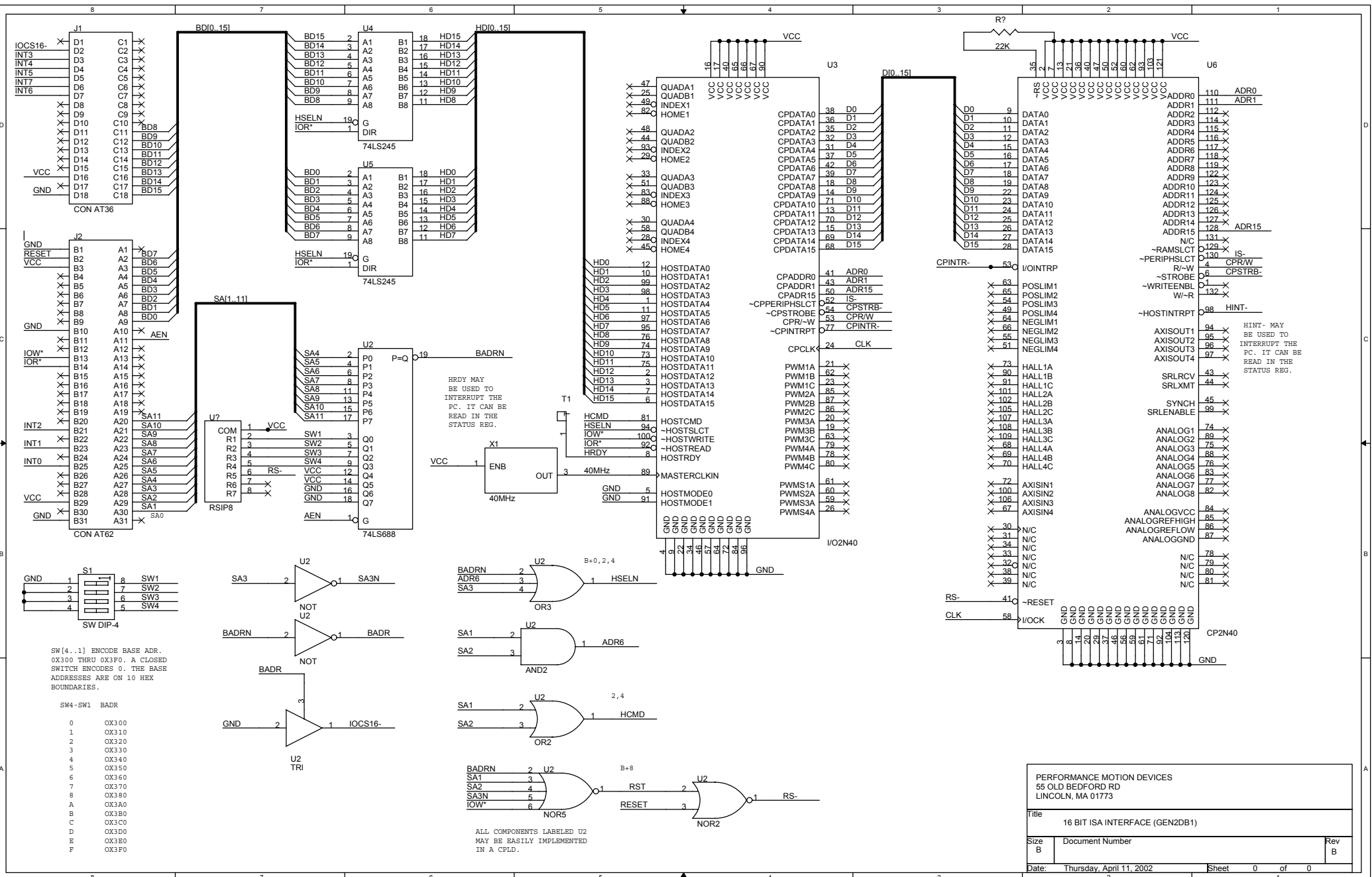

PERFORMANCE MOTION DEVICES
 55 OLD BEDFORD RD
 LINCOLN, MA 01773

Title: 16 BIT ISA INTERFACE (GEN2DB1)

Size: B	Document Number	Rev: B
---------	-----------------	--------

Date: Thursday, April 11, 2002 Sheet: 0 of 0

6.3 RS-232 Serial Interface

The interface between the Navigator chipset and an RS-232 serial port is shown in the following figure.

Comments on Schematic

S1 and S2 encode the characteristics of the serial port such as baud rate, number of stop bits, parity, etc. The CP will read these switches during initialization, but these parameters may also be set or changed using the **SetSerialPort** chipset command. The DB9 connector wired as shown can be connected directly to the serial port of a PC without requiring a null modem cable.

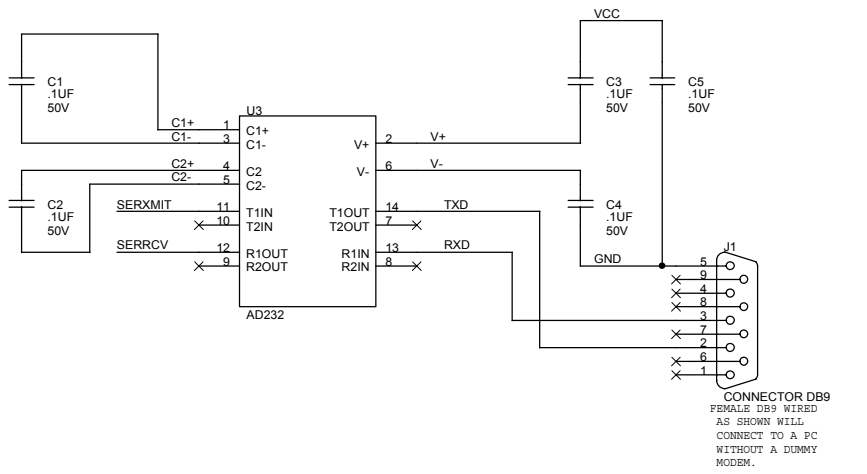
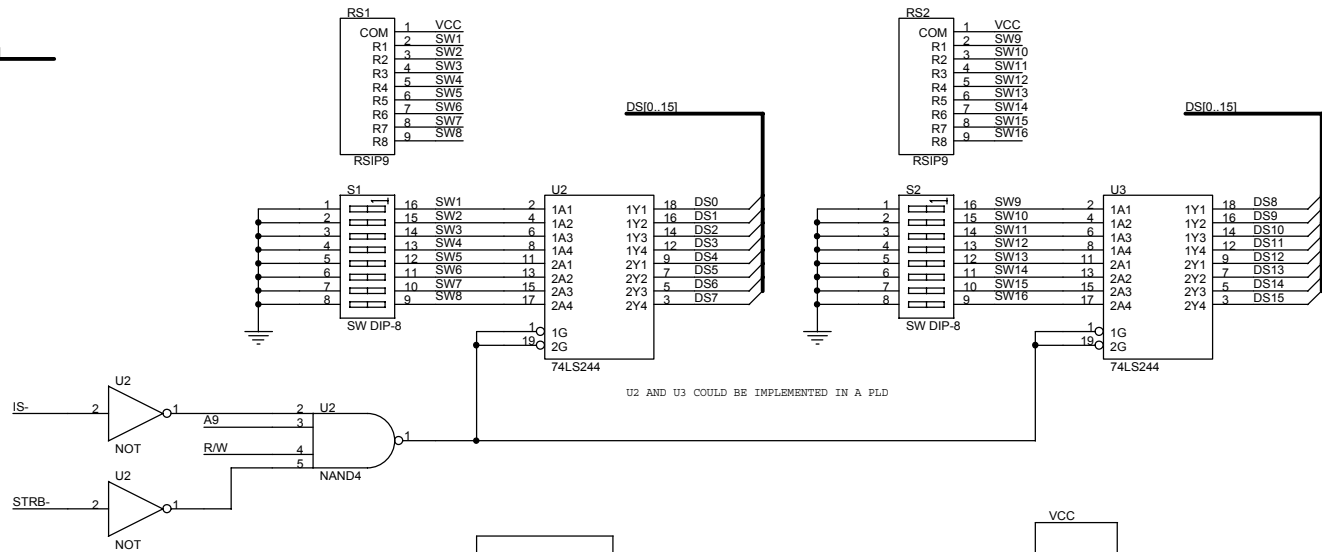
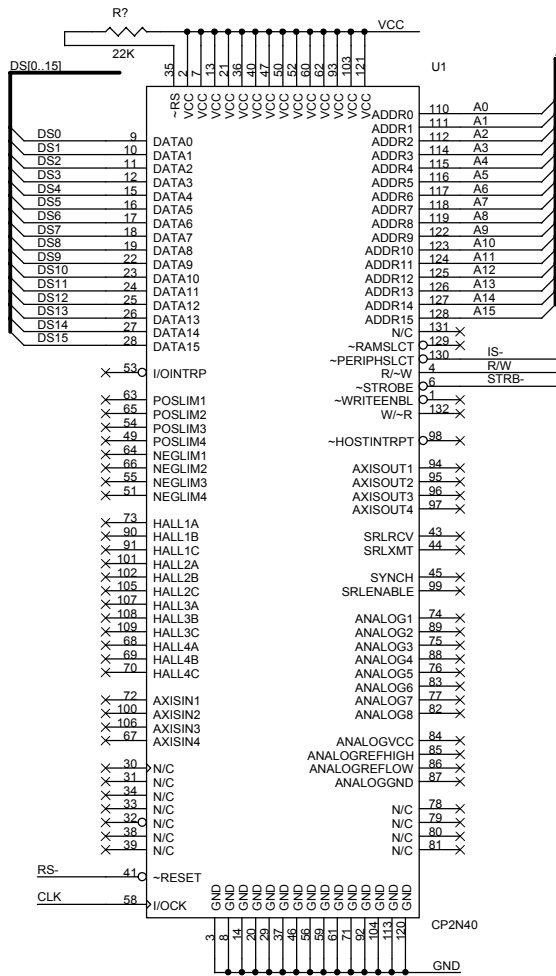

PERFORMANCE MOTION DEVICES
55 OLD BEDFORD RD
LINCOLN, MA 01773

Title: RS232 SERIAL INTERFACE (GEN2DG1)

Size B Document Number Rev B

Date: Thursday, April 11, 2002 Sheet 1 of 0

6.4 RS 422/485 Serial Interface

The interface between the Navigator chipset and an RS-422/485 serial port is shown in the following figure.

Comments on Schematic

Use the included table to determine the jumper setup that matches the chosen configuration. If using RS485, the last CP must have its jumpers set to RS485 LAST. The DB9 connector wiring is for example only. The DB9 should be wired according to the specification that accompanies the connector to which it is attached.

For correct operation, logic should be provided that contains the start up serial configuration for the chipset. Refer to the RS232 Serial Interface schematic for an example of the required logic.

Note that the RS485 interface cannot be used in point to point mode. It can only be used in a multi-drop configuration where the chip SrlEnable line is used to control transmit/receive operation of the serial transceiver.

Chips in a multi-drop environment should not be operated at different baud rates. This will result in communication problems.

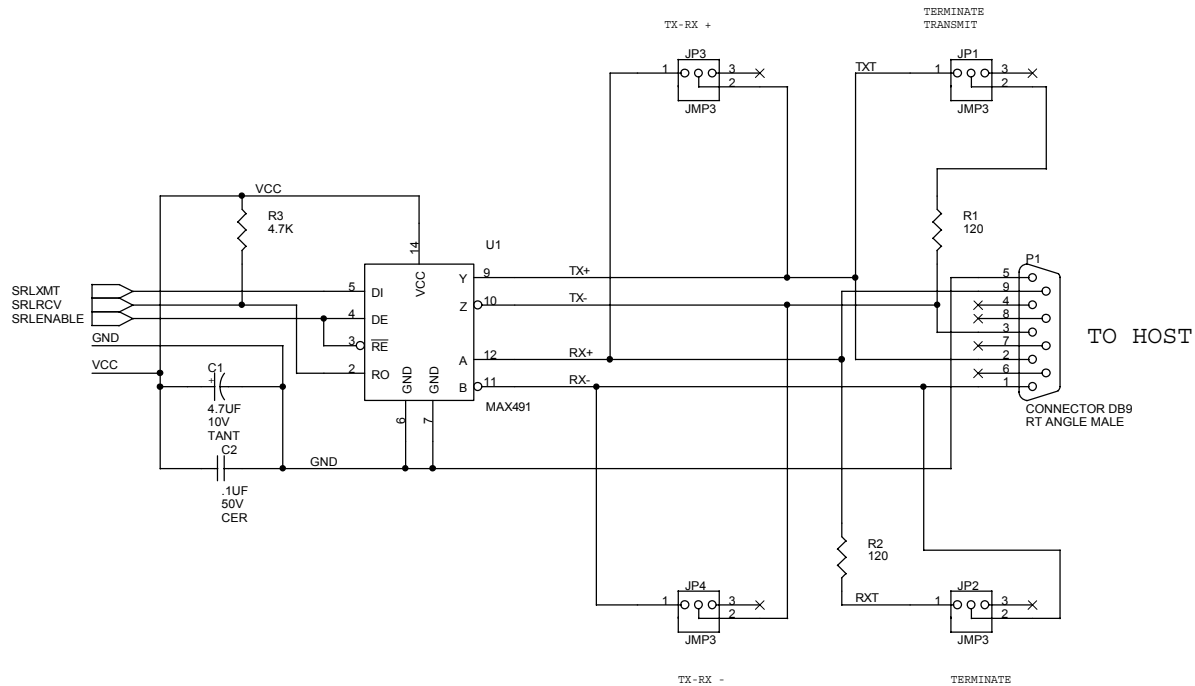

COM TYPE	JP1	JP2	JP3	JP4
RS422	1-2	1-2	2-3	2-3
RS485	2-3	2-3	1-2	1-2
RS485 LAST	1-2	2-3	1-2	1-2

NOTE:RS422 IS CAPABLE OF FULL DUPLEX AND USES 2 PAIRS.
 RS485 IS HALF-DUPLEX ON 1 PAIR AND MAY BE DAISY CHAINED
 THE CP USES RS485. A SINGLE CP MAY COMMUNICATE WITH AN
 RS422 HOST AS SHOWN IN THE TABLE.
 A SINGLE PAIR MAY BE WIRED TO EITHER P1-1,9 OR P1-2,3
 FOR RS485.

PERFORMANCE MOTION DEVICES 55 OLD BEDFORD RD LINCOLN, MA 01773		
Title RS422/485 Interface (GENDO1)		
Size B	Document Number	Rev A
Date: Thursday, April 11, 2002	Sheet 2	1 of 1

6.5 PWM Motor Interface

The following schematic shows a typical interface circuit between the MC2340 and an amplifier used in PWM 50/50 output mode.

Comments on Schematic

The L6234 from ST MicroElectronics is an integrated package that provides 3 half-bridge amplifiers on a single chip. It can drive up to 2 Amps continuous at 52 Volts.

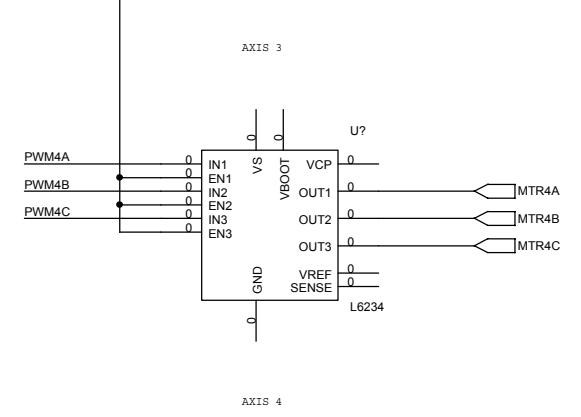
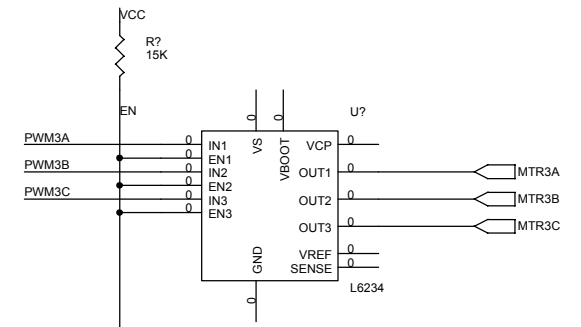
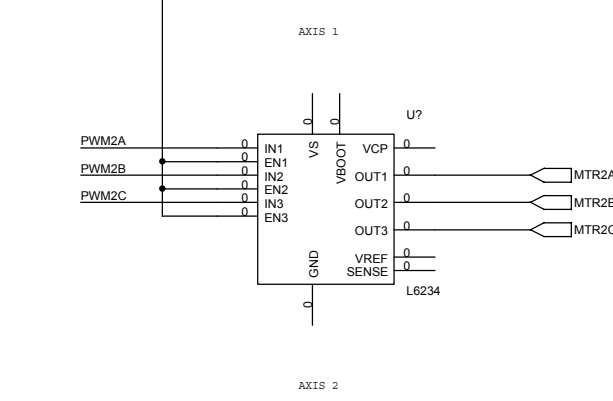
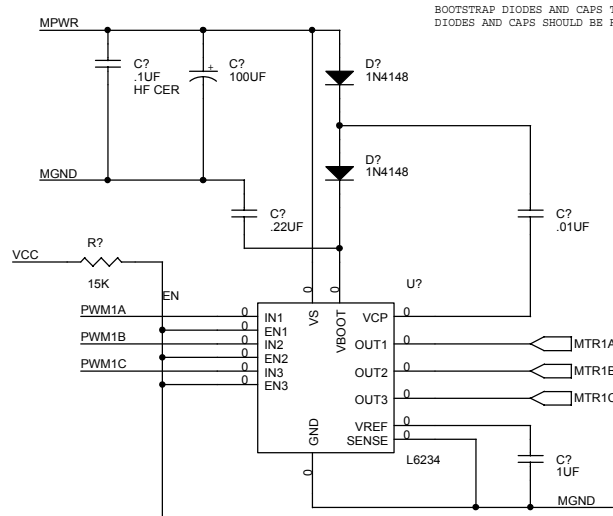
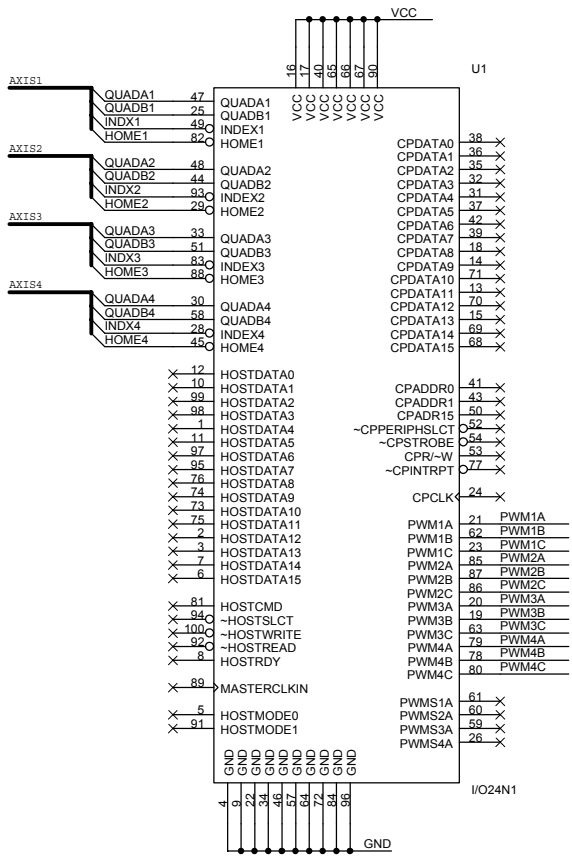

BOOTSTRAP DIODES AND CAPS TYPICAL EACH AXIS
DIODES AND CAPS SHOULD BE RATED 2-3 TIMES MPWR VOLTAGE

NOTE: L6234 AVAILABLE FROM ST MICROELECTRONICS
FORMERLY SGS-THOMPSON

PERFORMANCE MOTION DEVICES 55 OLD BEDFORD RD LINCOLN, MA 01773		
Title 3 Phase PWM 50/50 (GEN2DN1)		
Size B	Document Number	Rev B
Date: Thursday, April 11, 2002	Sheet 1	of 1

6.6 12-bit Parallel DAC Interface

The interface between the MC2340 chip set and 2 quad 12 bit DAC'S is shown in the following figure.

Comments on Schematic

The 12 data bits are written to the DAC addressed by address bits A0 and A1 in Quad DAC 1, when A2 is 0. The 12 data bits are written to the DAC addressed by address bits A0 and A1 in quad DAC 2, when A2 is 1. In this fashion CP addresses 4000,4002,4004,and 4006 are used for axis 1-4, phase A, and 4001,4003, 4005, and 4007, are used for axis 1-4 phase B.

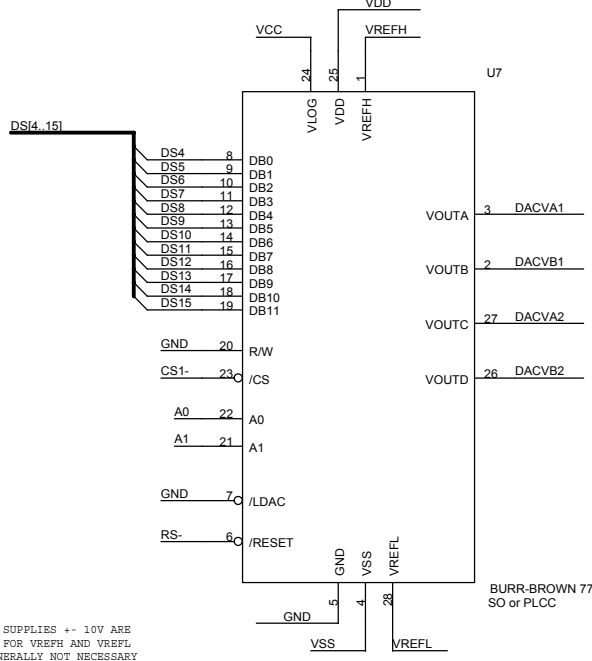
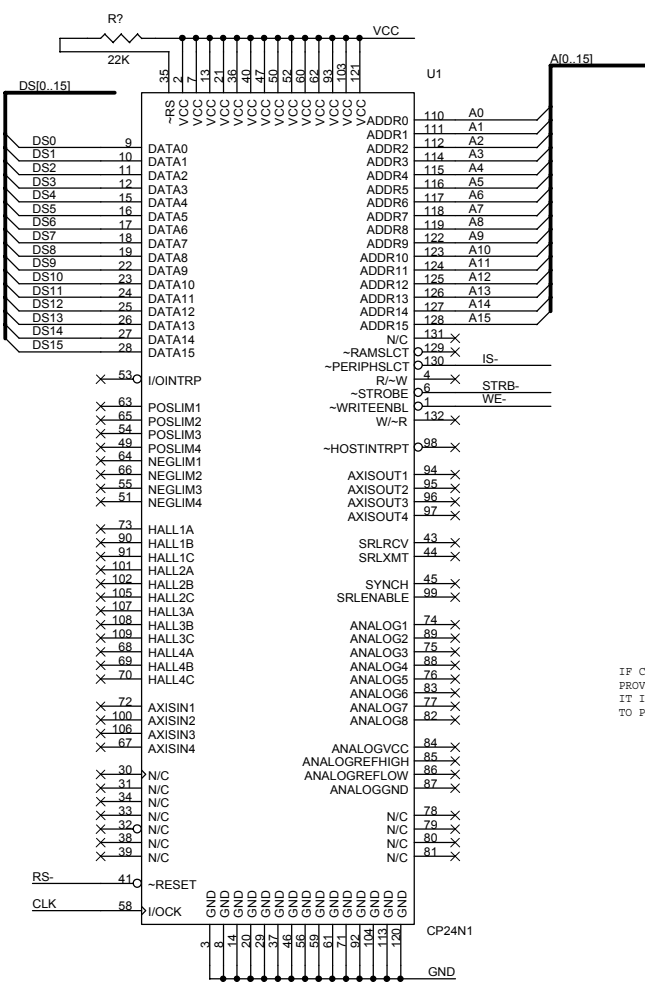

IF CLEAN SUPPLIES +/- 10V ARE PROVIDED FOR VREFH AND VREFL IT IS GENERALLY NOT NECESSARY TO PROVIDE OFFSET ADJUST.

4 DACS @ CP ADR
0X4000+ 0, 1, 2, 3.

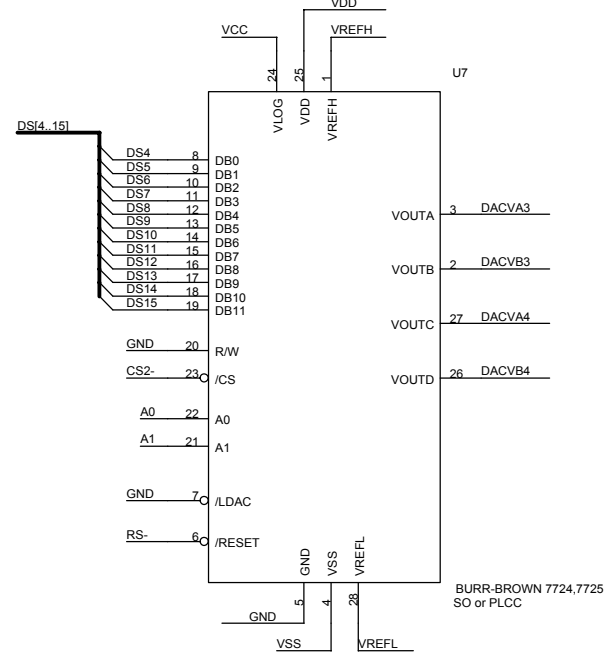
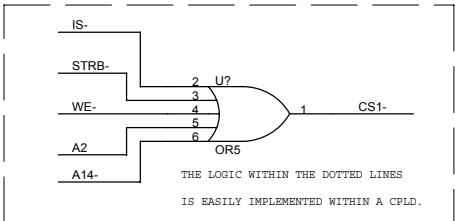

4 DACS @ CP ADR
0X4000+ 4, 5, 6, 7.

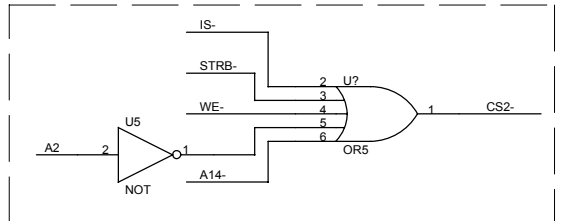

PERFORMANCE MOTION DEVICES 55 OLD BEDFORD RD LINCOLN, MA 01773		
Title 2 or 3 Phase 12-bit DAC OUT (GEN2DE1)		
Size B	Document Number	Rev B
Date: Thursday, April 11, 2002	Sheet	1 of 1

6.7 16-bit Serial DAC Interface

The following schematic shows an interface circuit between the MC2340 and a dual 16-bit serial DAC.

Comments on Schematic

The 16 data bits from the CP chip are latched in the two 74H165 shift registers when the CP writes to address 400x hex, and the address bits A1 and A2 are latched in the 2 DLAT latches and decoded by the 138 CPU cycle. The fed-back and-or gate latches, the decoded WRF, and the next clock will clear the 1st sequencer flop DFF3. This will disable the WRF latch and the second clock will clear the second DFF3 flop, forcing DACWRN low, and setting the first flop since WRF will have gone high. DACWRN low will clear the 74109, SHFTCNTN. The 4 bit counter, 74161, is also parallel loaded to 0, and the counter is enabled by ENP going high. The counter will not start counting nor the shift register start shifting until the clock after the DACWRN flop sets since the load overrides the count enable. When the DACWR flop is set the shift register will start shifting and the counter will count the shifts. After 15 shifts CNT15 from the counter will go high and the next clock will set the DACLAT flop and set the SHFTCNTN flop. This will stop the shift after 16 shifts and assert L1 through L4 depending on the address stored in the latch. The 16th clock also was counted causing the counter to roll over to 0 and CNT15 to go low. The next clock will therefore clear the DACLAT flop causing the DAC latch signal L1 through L4 to terminate and the 16 bits of data to be latched in the addressed DAC. The control logic is now back in its original state waiting for the next write to the DACs by the CP. SERCK is a 10MHz clock, the 20MHz CP clock divided by 2, since the AD1866 DACs will not run at 20MHz.

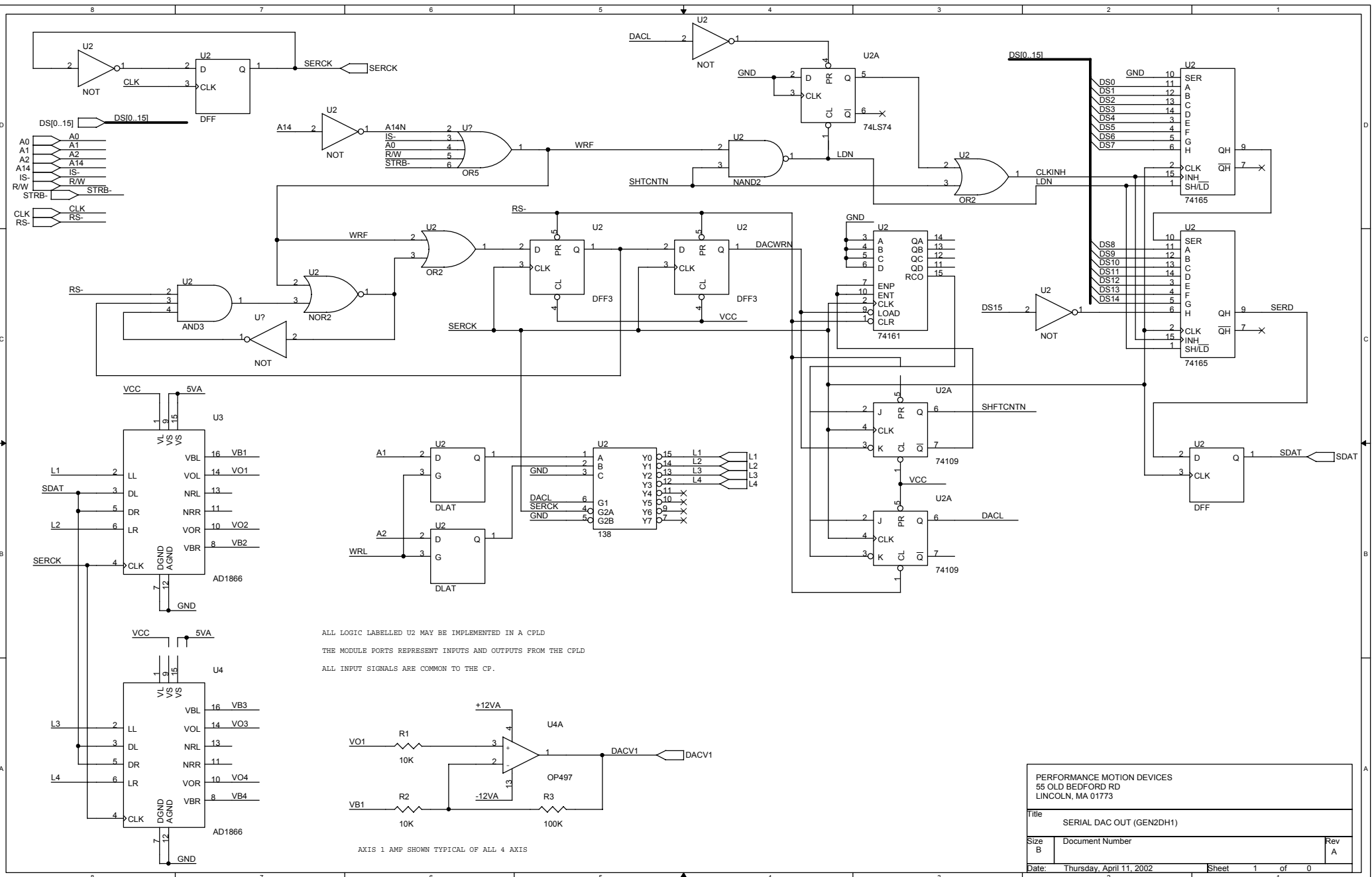

PERFORMANCE MOTION DEVICES 55 OLD BEDFORD RD LINCOLN, MA 01773		
Title SERIAL DAC OUT (GEN2DH1)		
Size B	Document Number	Rev A
Date: Thursday, April 11, 2002	Sheet 1	of 0

6.8 12-bit A/D Interface

The following schematic shows a typical interface circuit between the Navigator chipset and a quad 12 bit 2's complement A/D converter used as a position input device.

Comments on Schematic

The A/D converter samples all 4 axes and sequentially converts and stores the 2's complement digital words. The data is read out sequentially, axis 1 to 4. DACRD- is used to perform the read and is also used to load the counter to FFh. The counter will be reloaded for each read and will not count significantly between reads. The counter will therefore start counting down after the last read and will generate the cvt- pulse after 12.75 μ sec. The conversions will take approximately 35 μ sec, and the data will be available for the next set of reads after 50 μ sec. The 12 bit words from the A/D are extended to 16 bits with the 74LS244.

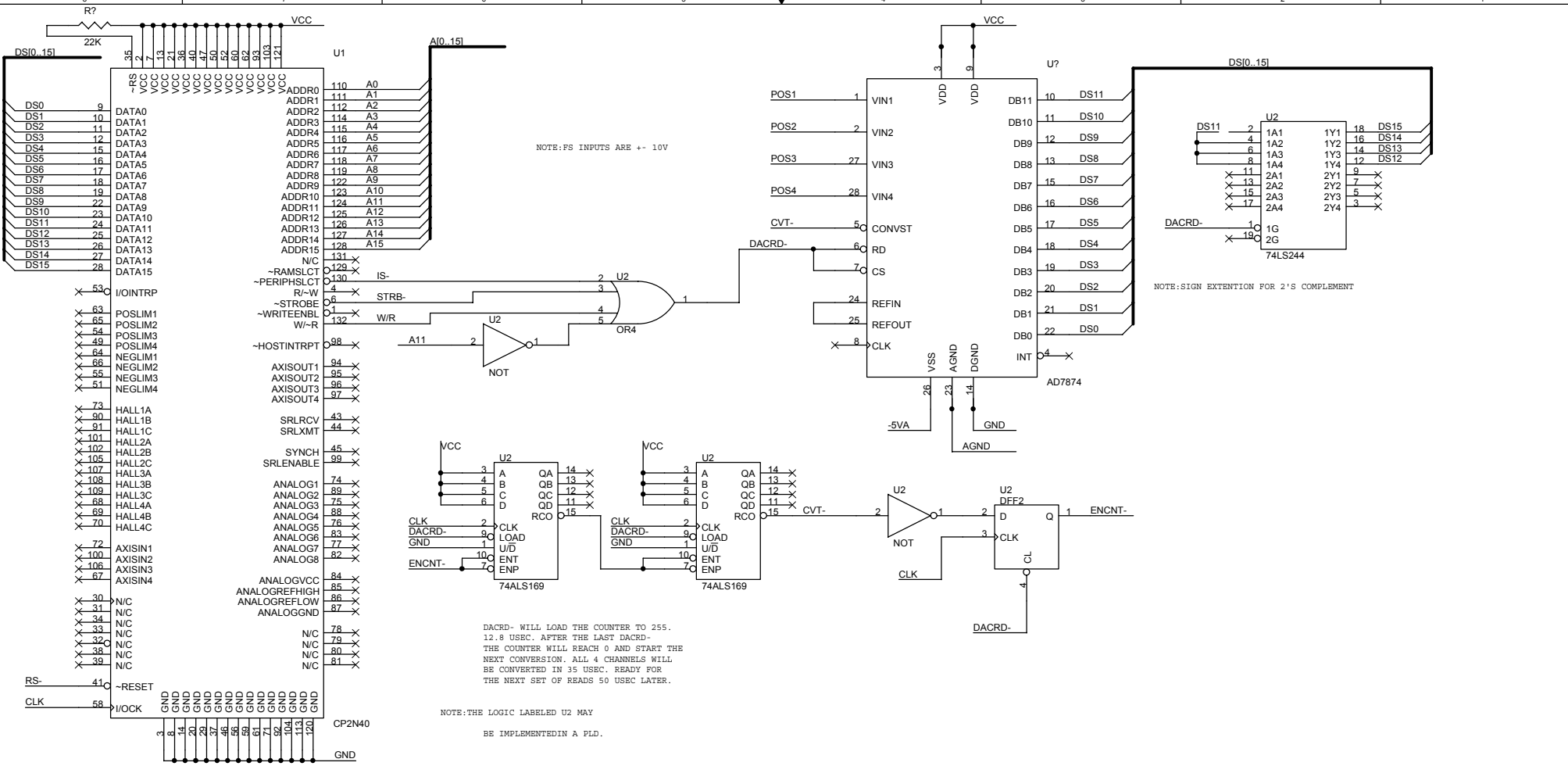

NOTE:FS INPUTS ARE +- 10V

NOTE:SIGN EXTENSION FOR 2'S COMPLEMENT

DACRD- WILL LOAD THE COUNTER TO 255.
 12.8 USEC. AFTER THE LAST DACRD-
 THE COUNTER WILL REACH 0 AND START THE
 NEXT CONVERSION. ALL 4 CHANNELS WILL
 BE CONVERTED IN 35 USEC. READY FOR
 THE NEXT SET OF READS 50 USEC LATER.

NOTE:THE LOGIC LABELED U2 MAY
 BE IMPLEMENTED IN A PLD.

PERFORMANCE MOTION DEVICES 55 OLD BEFORD RD LINCOLN, MA 01773		
Title 12 BIT A/D IN (GEN2DC1)		
Size B	Document Number	Rev B
Date: Thursday, April 11, 2002	Sheet 1	of 0

6.9 16-bit A/D Input

The interface between the Navigator chipset and 16 bit A/D converters as parallel input position devices is shown in the following figure.

Comments on Schematic

The schematic shows a 16 bit A/D used to provide parallel position input to axis 1 and axis 2. The expansion to the remaining two axes is easily implemented. The 374 registers are required on the output of the A/D converters to make the 68-nanosecond access time of the CP. The worst-case timing of the A/D's specify 83 nanoseconds for data on the bus and 83 nanoseconds from data to tri-state on the bus. Each time the data is read the 169 counter is set to 703 decimal. This provides a 35.2-microsecond delay before the next conversion. With a 10-microsecond conversion time the data will be available for the next set of reads after 50 microseconds. The delay is used to provide a position sample close to the actual position.

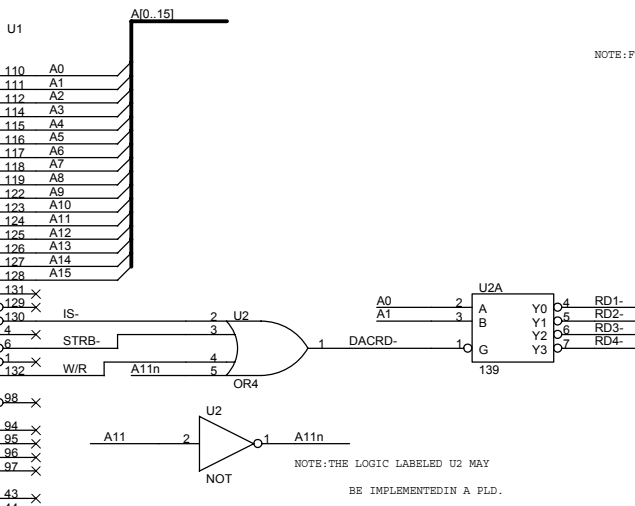
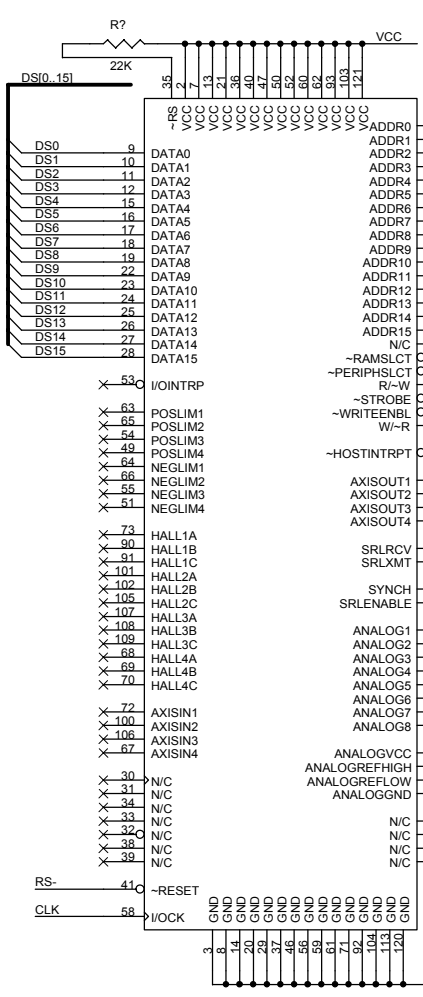

NOTE: FS INPUTS ARE +- 10V

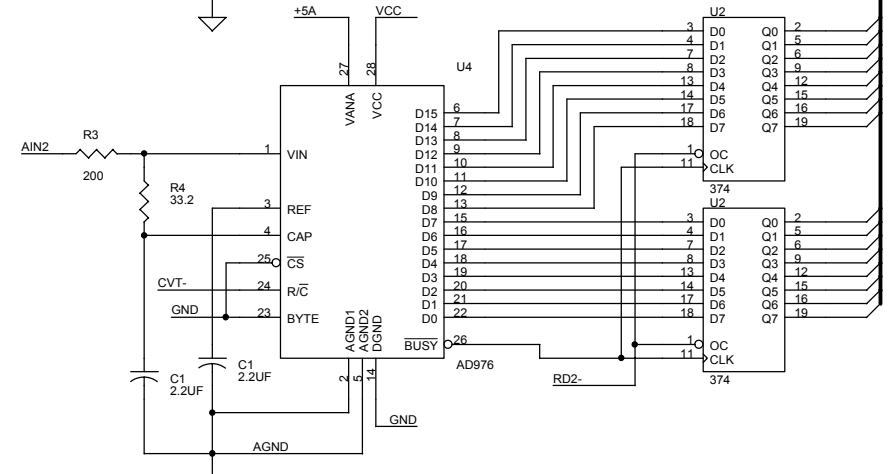
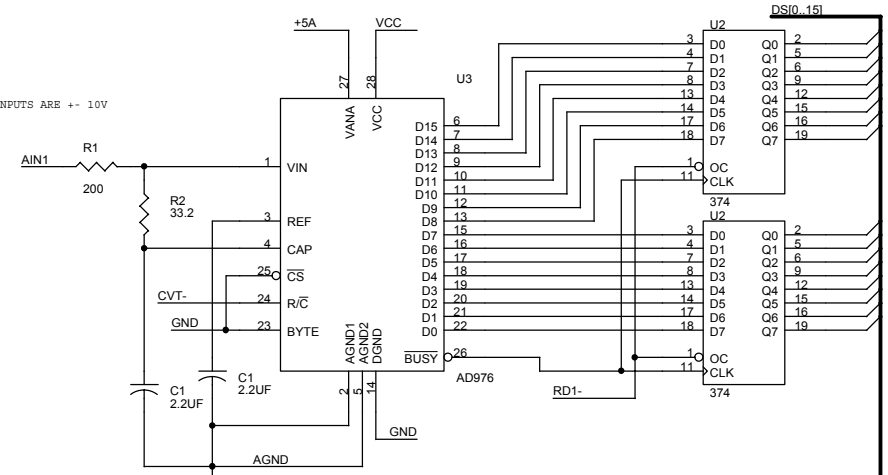

NOTE: AXIS 1 AND 2 ARE SHOWN EXPLICITLY. AXIS 3 AND 4 MAY BE IMPLEMENTED IN AN IDENTICAL FASHION.
SEE ANALOG DEVICES SPECIFICATIONS FOR ADDITIONAL INFORMATION AND POWER BYPASSING.

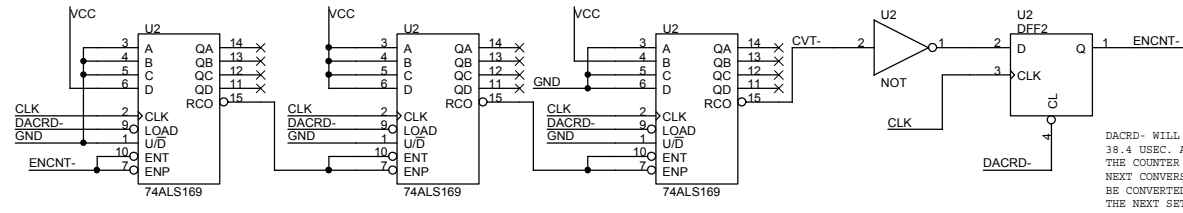

DACRD- WILL LOAD THE COUNTER TO 700. 38.4 USEC. AFTER THE LAST DACRD- THE COUNTER WILL REACH 0 AND START THE NEXT CONVERSION. ALL 4 CHANNELS WILL BE CONVERTED IN 10 USEC. READY FOR THE NEXT SET OF READS AFTER 50 USEC.

PERFORMANCE MOTION DEVICES 55 OLD BEDFORD RD LINCOLN, MA 01773		
Title	16 BIT A/D INPUT (GEN2DL1)	
Size	Document Number	Rev B
Date:	Thursday, April 11, 2002	Sheet 1 of 1

6.10 RAM Interface

The following schematic shows an interface circuit between the Navigator chipset and external ram.

Comments on Schematic

The CP is capable of directly addressing 32K words of 16-bit memory. It will also use a 16 bit paging register to address up to 32K word pages. The schematic shows the paging and addressing for 128KB RAM chips, i.e. 4 pages per RAM chip. The page address decoding is shown for only 6 of the 16 possible paging bits. The decoding time from W/R and DS- to the memory output must not exceed 18 ns. for a read with no wait states. The writes provide 25 extra ns access time for W/R and DS- to reverse the CP data bus.

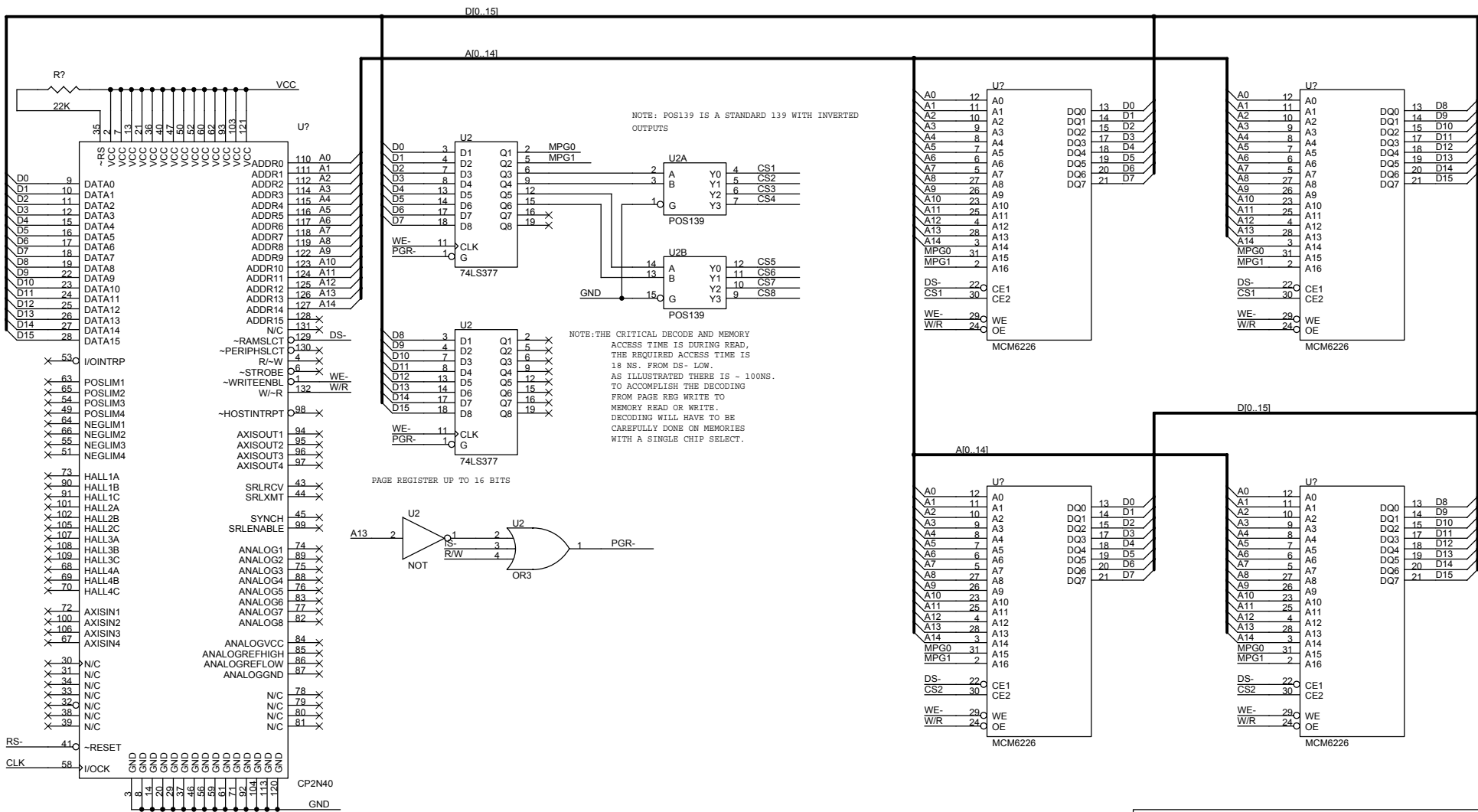

PERFORMANCE MOTION DEVICES 55 OLD BEDFORD RD LINCOLN, MA 01773			
Title		RAM INTERFACE (GEN2DF1)	
Size	Document Number		Rev
B			B
Date:	Thursday, April 11, 2002	Sheet	1 of 0

6.11 User-defined I/O

The interface between the Navigator chipset and 16 bits of user output and 16 bits of user input is shown in the following figure.

Comments on Schematic

The schematic implements 1 word of user output registered in the 74LS377's and 1 word of user inputs read via the 244's. The schematic decodes the low 3 bits of the address to 8 possible UIO addresses UIO0 through UIO7. Registers and buffers are shown for only UIO0, but the implementation shown may be easily extended. The lower 8 address bits may be decoded to provide up to 256 user output words and 256 user input words of 16 bits.

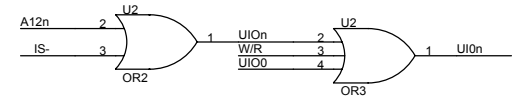
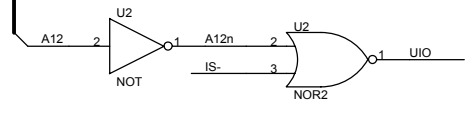
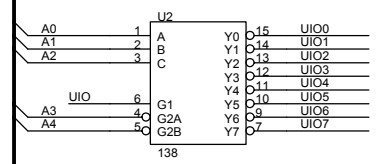
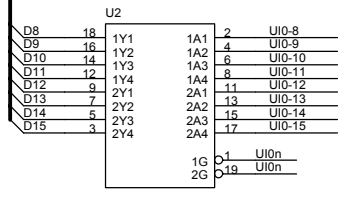
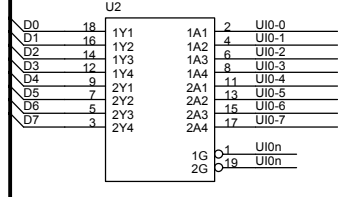
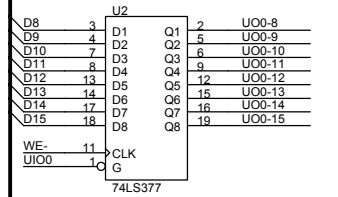
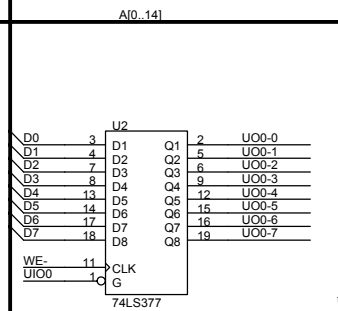
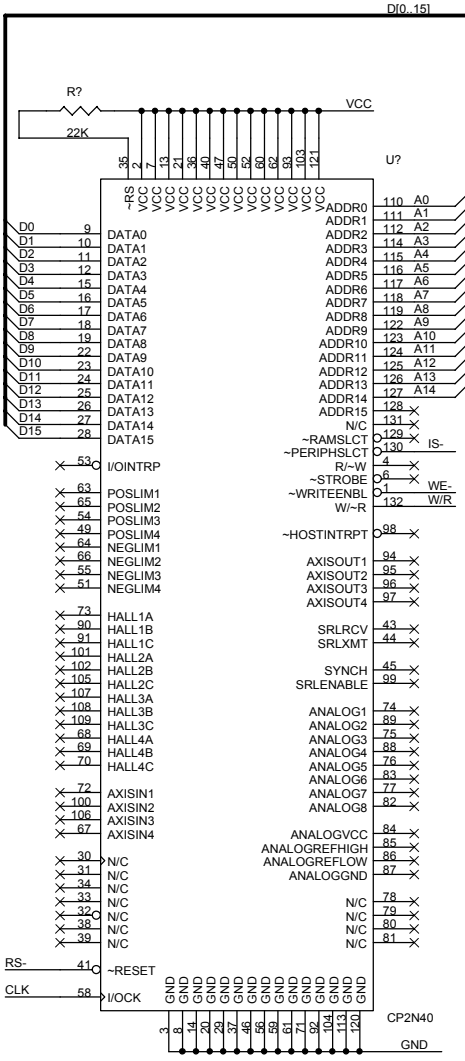

THE LOGIC LABELED U2 MAY BE IMPLEMENTED IN A CPLD. THE LOWER 8 ADDRESS BITS, A0-A8, MAY BE DECODED TO PROVIDE 256 16 BIT USER INPUTS AND 256 USER OUTPUTS.

PERFORMANCE MOTION DEVICES 55 OLD BEDFORD RD LINCOLN, MA 01773		
Title: USER I/O (GENZDK1)		
Size: B	Document Number	Rev: D
Date: Thursday, April 11, 2002	Sheet: 1	of 0