

International
IR Rectifier

DIGITAL AUDIO MOSFET**IRFB4019PbF****Features**

- Key Parameters Optimized for Class-D Audio Amplifier Applications
- Low $R_{DS(ON)}$ for Improved Efficiency
- Low Q_G and Q_{SW} for Better THD and Improved Efficiency
- Low Q_{RR} for Better THD and Lower EMI
- 175°C Operating Junction Temperature for Ruggedness
- Can Deliver up to 200W per Channel into 8Ω Load in Half-Bridge Configuration Amplifier

Key Parameters

V_{DS}	150	V
$R_{DS(ON)}$ typ. @ 10V	80	mΩ
Q_g typ.	13	nC
Q_{sw} typ.	5.1	nC
$R_{G(int)}$ typ.	2.4	Ω
T_J max	175	°C

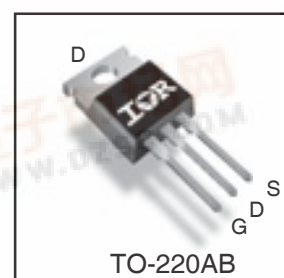
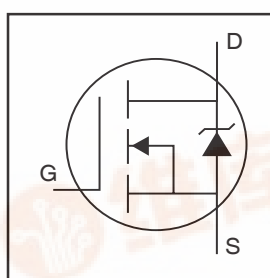

G	D	S
Gate	Drain	Source

Description

This Digital Audio MOSFET is specifically designed for Class-D audio amplifier applications. This MOSFET utilizes the latest processing techniques to achieve low on-resistance per silicon area. Furthermore, Gate charge, body-diode reverse recovery and internal Gate resistance are optimized to improve key Class-D audio amplifier performance factors such as efficiency, THD and EMI. Additional features of this MOSFET are 175°C operating junction temperature and repetitive avalanche capability. These features combine to make this MOSFET a highly efficient, robust and reliable device for ClassD audio amplifier applications.

Absolute Maximum Ratings

	Parameter	Max.	Units
V_{DS}	Drain-to-Source Voltage	150	V
V_{GS}	Gate-to-Source Voltage	±20	
I_D @ $T_C = 25^\circ\text{C}$	Continuous Drain Current, V_{GS} @ 10V	17	A
I_D @ $T_C = 100^\circ\text{C}$	Continuous Drain Current, V_{GS} @ 10V	12	
I_{DM}	Pulsed Drain Current ①	51	
P_D @ $T_C = 25^\circ\text{C}$	Power Dissipation ④	80	W
P_D @ $T_C = 100^\circ\text{C}$	Power Dissipation ④	40	
	Linear Derating Factor	0.5	W/°C
T_J	Operating Junction and	-55 to + 175	°C
T_{STG}	Storage Temperature Range		
	Soldering Temperature, for 10 seconds (1.6mm from case)	300	
	Mounting torque, 6-32 or M3 screw	10lb·in (1.1N·m)	

Thermal Resistance

	Parameter	Typ.	Max.	Units
$R_{\theta JC}$	Junction-to-Case ④	—	1.88	°C/W
$R_{\theta CS}$	Case-to-Sink, Flat, Greased Surface	0.50	—	
$R_{\theta JA}$	Junction-to-Ambient ④	—	62	

IRFB4019PbF

International
IOR Rectifier

Electrical Characteristics @ T_J = 25°C (unless otherwise specified)

	Parameter	Min.	Typ.	Max.	Units	Conditions
BV _{DSS}	Drain-to-Source Breakdown Voltage	150	---	---	V	V _{GS} = 0V, I _D = 250μA
ΔBV _{DSS} /ΔT _J	Breakdown Voltage Temp. Coefficient	---	0.19	---	V/°C	Reference to 25°C, I _D = 1mA
R _{DS(on)}	Static Drain-to-Source On-Resistance	---	80	95	mΩ	V _{GS} = 10V, I _D = 10A ③
V _{GS(th)}	Gate Threshold Voltage	3.0	---	4.9	V	V _{DS} = V _{GS} , I _D = 50μA
ΔV _{GS(th)} /ΔT _J	Gate Threshold Voltage Coefficient	---	-13	---	mV/°C	
I _{DSS}	Drain-to-Source Leakage Current	---	---	20	μA	V _{DS} = 150V, V _{GS} = 0V
		---	---	250		V _{DS} = 150V, V _{GS} = 0V, T _J = 125°C
I _{GSS}	Gate-to-Source Forward Leakage	---	---	100	nA	V _{GS} = 20V
	Gate-to-Source Reverse Leakage	---	---	-100		V _{GS} = -20V
g _{fs}	Forward Transconductance	14	---	---	S	V _{DS} = 10V, I _D = 10A
Q _g	Total Gate Charge	---	13	20		
Q _{gs1}	Pre-V _{th} Gate-to-Source Charge	---	3.3	---		V _{DS} = 75V
Q _{gs2}	Post-V _{th} Gate-to-Source Charge	---	0.95	---	nC	V _{GS} = 10V
Q _{gd}	Gate-to-Drain Charge	---	4.1	---		I _D = 10A
Q _{godr}	Gate Charge Overdrive	---	4.7	---		See Fig. 6 and 19
Q _{sw}	Switch Charge (Q _{gs2} + Q _{gd})	---	5.1	---		
R _{G(int)}	Internal Gate Resistance	---	2.4	---	Ω	
t _{d(on)}	Turn-On Delay Time	---	7.0	---		V _{DD} = 75V, V _{GS} = 10V ③
t _r	Rise Time	---	13	---	ns	I _D = 10A
t _{d(off)}	Turn-Off Delay Time	---	12	---		R _G = 2.4Ω
t _f	Fall Time	---	7.8	---		
C _{iss}	Input Capacitance	---	800	---		V _{GS} = 0V
C _{oss}	Output Capacitance	---	74	---	pF	V _{DS} = 50V
C _{rss}	Reverse Transfer Capacitance	---	19	---		f = 1.0MHz, See Fig.5
C _{oss}	Effective Output Capacitance	---	99	---		V _{GS} = 0V, V _{DS} = 0V to 120V
L _D	Internal Drain Inductance	---	4.5	---		Between lead,
L _S	Internal Source Inductance	---	7.5	---	nH	6mm (0.25in.) from package and center of die contact

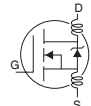

Avalanche Characteristics

	Parameter	Typ.	Max.	Units
E _{AS}	Single Pulse Avalanche Energy②	---	73	mJ
I _{AR}	Avalanche Current ⑤	See Fig. 14, 15, 17a, 17b		A
E _{AR}	Repetitive Avalanche Energy ⑤			mJ

Diode Characteristics

	Parameter	Min.	Typ.	Max.	Units	Conditions
I _S @ T _C = 25°C	Continuous Source Current (Body Diode)	---	---	17	A	MOSFET symbol showing the integral reverse p-n junction diode.
I _{SM}	Pulsed Source Current (Body Diode) ①	---	---	51		
V _{SD}	Diode Forward Voltage	---	---	1.3	V	T _J = 25°C, I _S = 10A, V _{GS} = 0V ③
t _{rr}	Reverse Recovery Time	---	64	96	ns	T _J = 25°C, I _F = 10A
Q _{rr}	Reverse Recovery Charge	---	160	240	nC	di/dt = 100A/μs ③

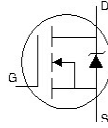

Notes:

① Repetitive rating; pulse width limited by max. junction temperature.

② Single pulse, T_J = 25°C, f = 100Hz, L_G = 6mH, R_G = 25Ω, I_{AS} = 10A.

③ Cycle ≤ 2%.

④ R_θ is measured at T_J of approximately 90°C.

⑤ Limited by T_{Jmax}. See Figs. 14, 15, 17a, 17b for repetitive avalanche information

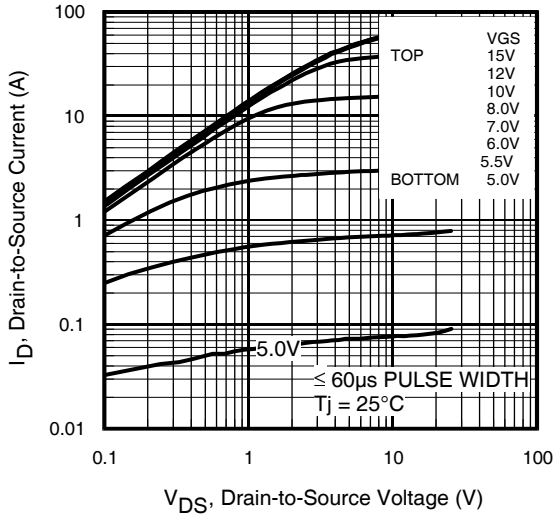

Fig 1. Typical Output Characteristics

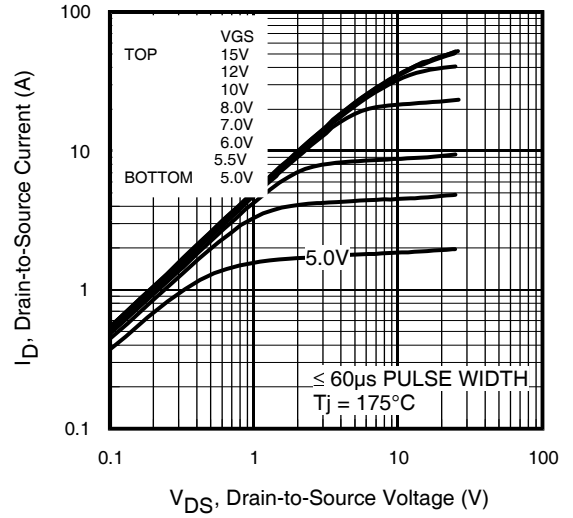

Fig 2. Typical Output Characteristics

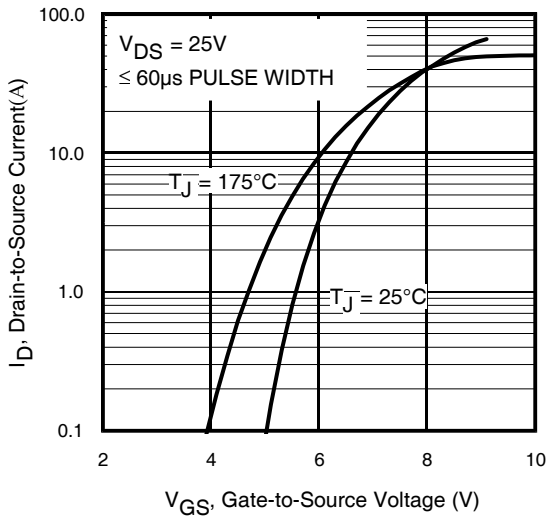

Fig 3. Typical Transfer Characteristics

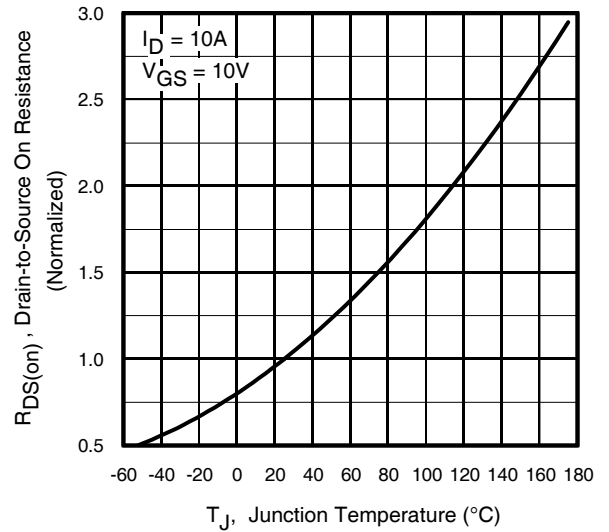

Fig 4. Normalized On-Resistance vs. Temperature

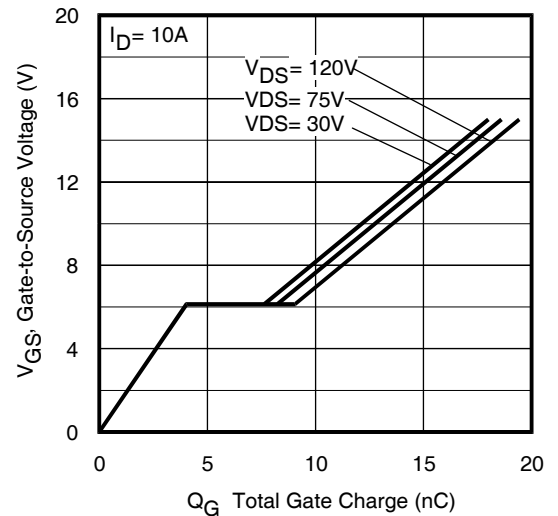
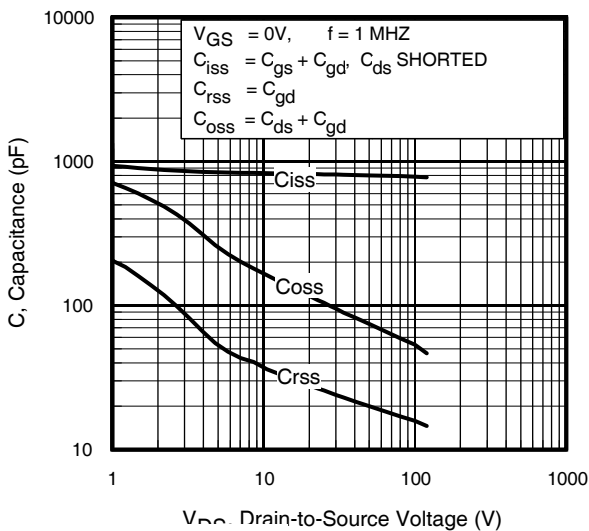

Fig 6. Typical Gate Charge vs. Gate-to-Source Voltage



IRFB4019PbF

International
IOR Rectifier

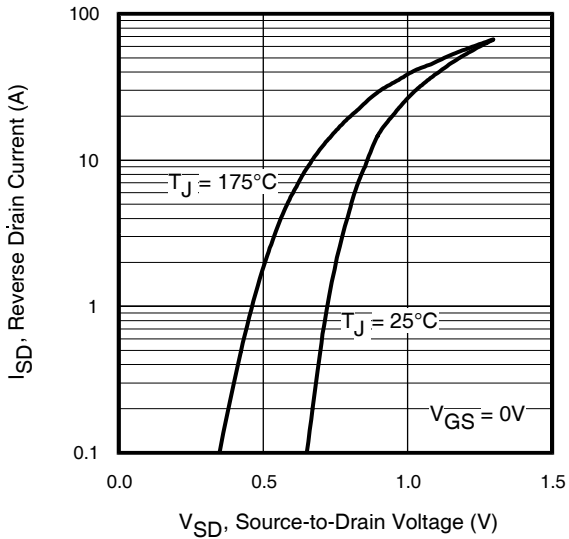

Fig 7. Typical Source-Drain Diode Forward Voltage

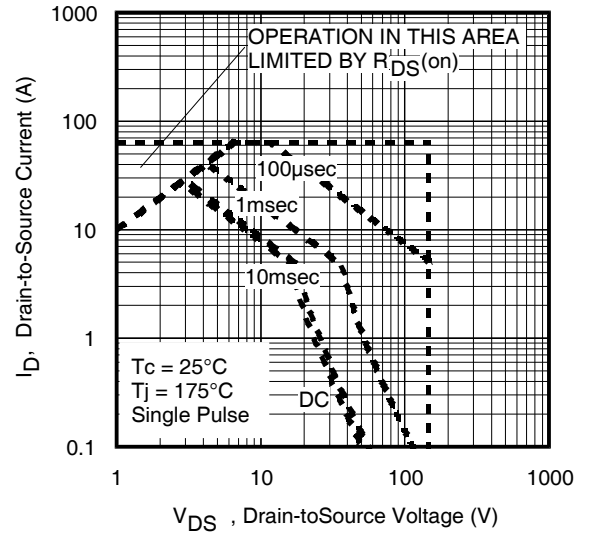

Fig 8. Maximum Safe Operating Area

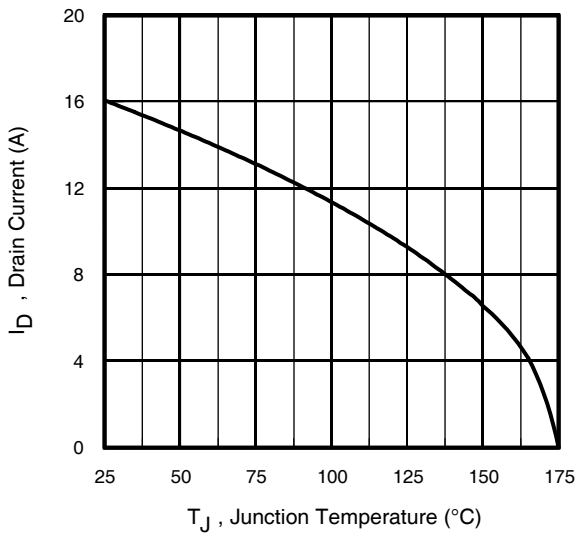

Fig 9. Maximum Drain Current vs. Case Temperature

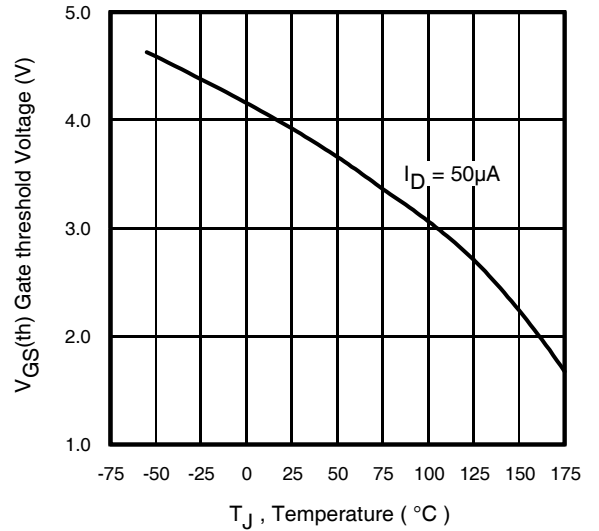
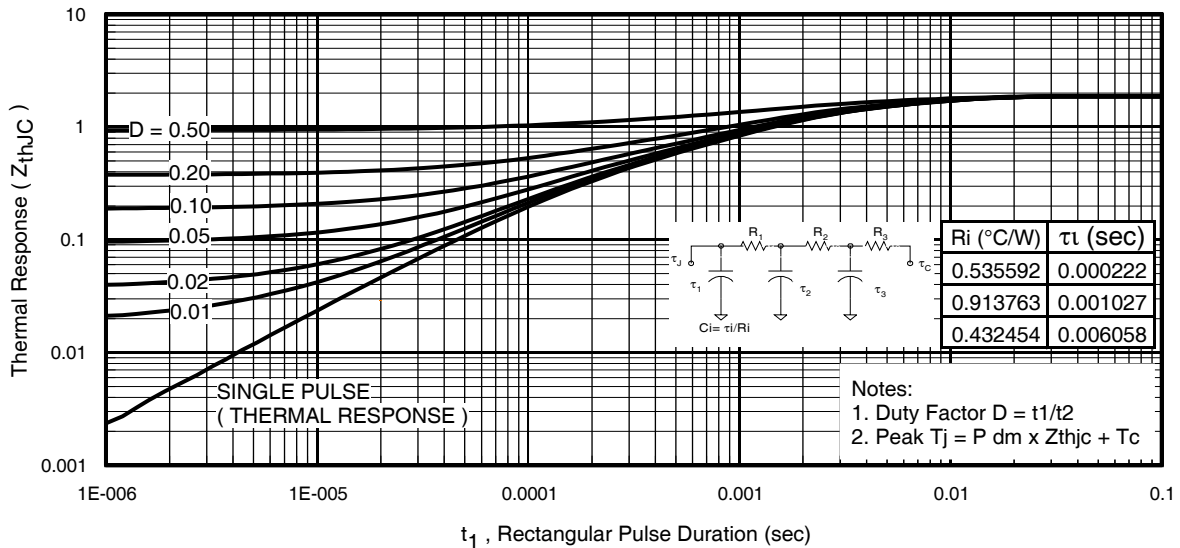

Fig 10. Threshold Voltage vs. Temperature



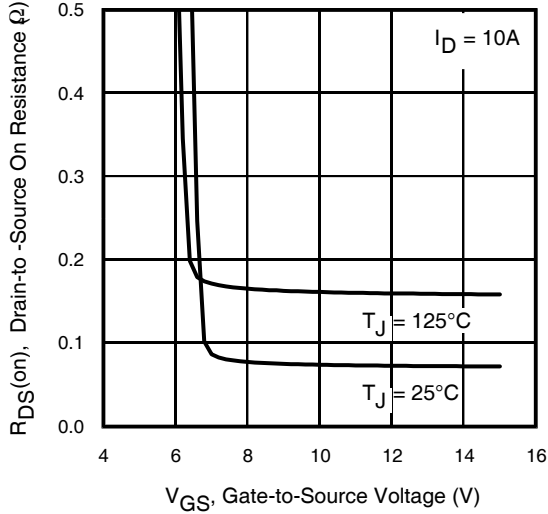

Fig 12. On-Resistance Vs. Gate Voltage

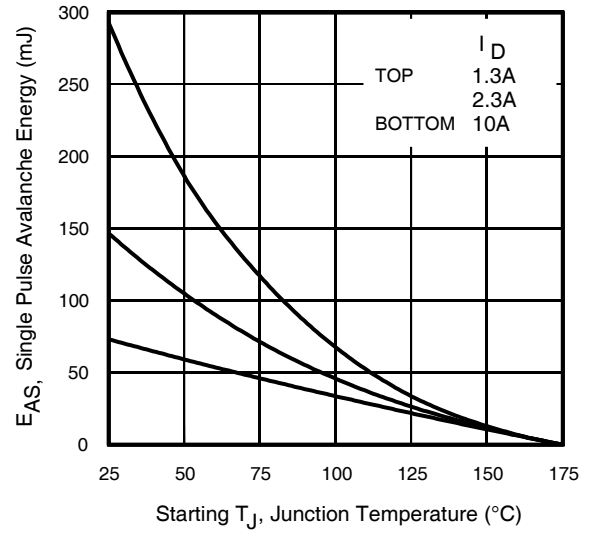

Fig 13. Maximum Avalanche Energy Vs. Drain Current

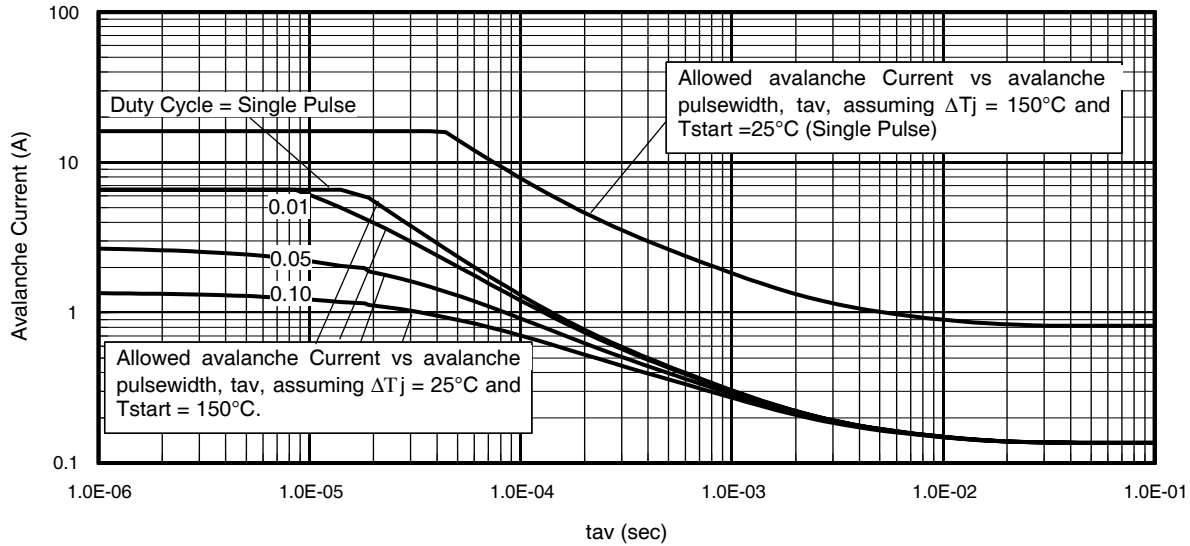
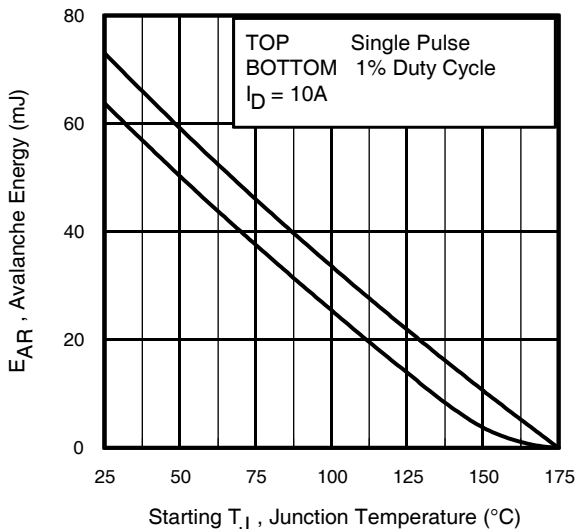

Fig 14. Typical Avalanche Current Vs. Pulsewidth



Notes on Repetitive Avalanche Curves , Figures 14, 15:
(For further info, see AN-1005 at www.irf.com)

1. Avalanche failures assumption:
Purely a thermal phenomenon and failure occurs at a temperature far in excess of T_{jmax} . This is validated for every part type.
2. Safe operation in Avalanche is allowed as long as neither T_{jmax} nor I_{av} (max) is exceeded
3. Equation below based on circuit and waveforms shown in Figures 17a, 17b.
4. $P_{D(ave)}$ = Average power dissipation per single avalanche pulse.
5. B_V = Rated breakdown voltage (1.3 factor accounts for voltage increase during avalanche).
6. I_{av} = Allowable avalanche current.
7. ΔT = Allowable rise in junction temperature, not to exceed T_{jmax} (assumed as 25°C in Figure 14, 15).
 t_{av} = Average time in avalanche.
 D = Duty cycle in avalanche = $t_{av} \cdot f$
 $Z_{thJC}(D, t_{av})$ = Transient thermal resistance, see figure 11)

$$P_{D(ave)} = 1/2 (1.3 \cdot B_V \cdot I_{av}) = \Delta T / Z_{thJC}$$

$$I_{av} = 2\Delta T / [1.3 \cdot B_V \cdot Z_{th}]$$

$$E_{AS(AR)} = P_{D(ave)} \cdot t_{av}$$



IRFB4019PbF

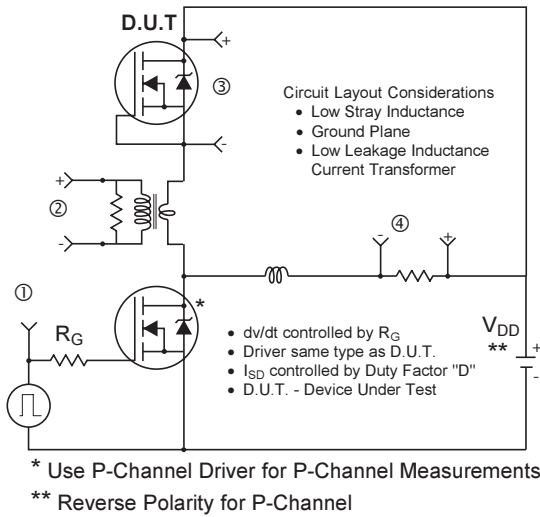

Fig 16. Diode Reverse Recovery Test Circuit for HEXFET® Power MOSFETs

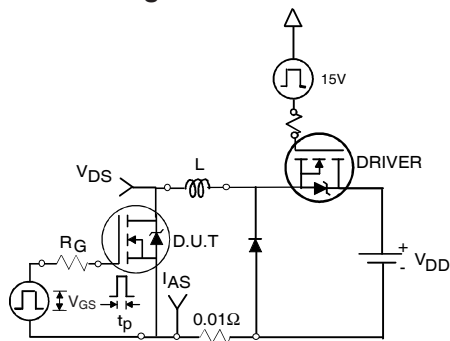
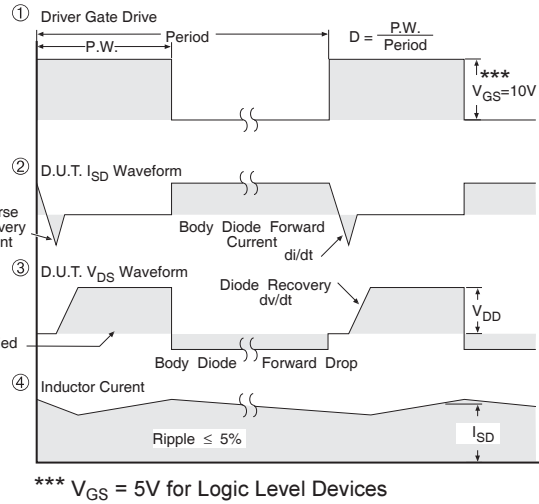

Fig 17a. Unclamped Inductive Test Circuit

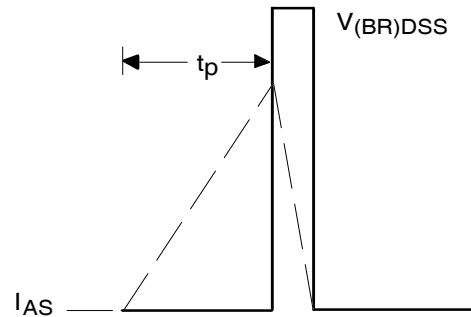

Fig 17b. Unclamped Inductive Waveforms

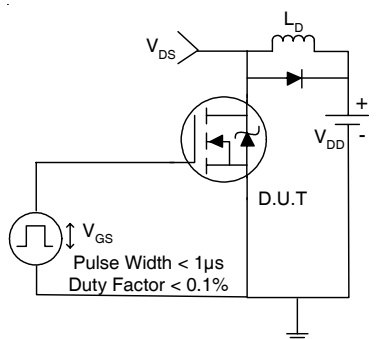

Fig 18a. Switching Time Test Circuit

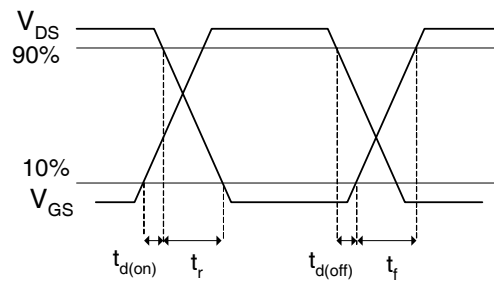

Fig 18b. Switching Time Waveforms

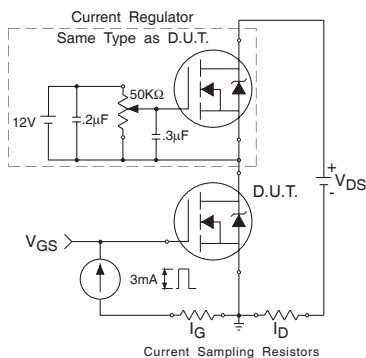

Fig 19a. Current Regulator Test Circuit

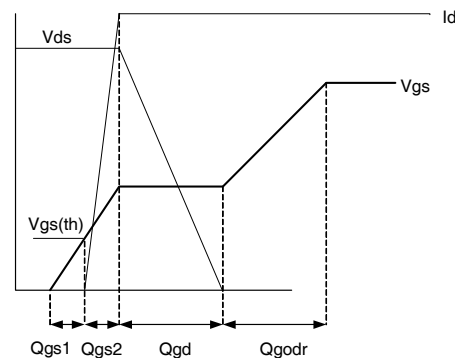
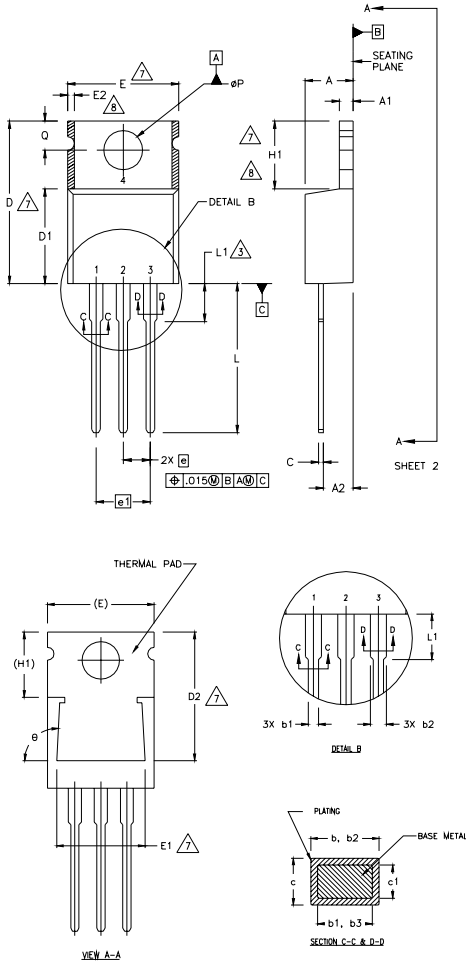

Fig 19b. Gate Charge Waveform



TO-220AB Package Outline (Dimensions are shown in millimeters (inches))



NOTES:

- 1 DIMENSIONING AND TOLERANCING PER ASME Y14.5 M- 1994.
- 2 DIMENSIONS ARE SHOWN IN INCHES [MILLIMETERS].
- 3 LEAD DIMENSION AND FINISH UNCONTROLLED IN L1.
- 4 DIMENSION D & E DO NOT INCLUDE MOLD FLASH. MOLD FLASH SHALL NOT EXCEED .005" (0.127) PER SIDE. THESE DIMENSIONS ARE MEASURED AT THE OUTERMOST EXTREMES OF THE PLASTIC BODY.
- 5 DIMENSION b1 & c1 APPLY TO BASE METAL ONLY.
- 6 CONTROLLING DIMENSION : INCHES.
- 7 THERMAL PAD CONTOUR OPTIONAL WITHIN DIMENSIONS E,H1,D2 & E1
- 8 DIMENSION E2 X H1 DEFINE A ZONE WHERE STAMPING AND SINGULATION IRREGULARITIES ARE ALLOWED.

LEAD ASSIGNMENTS

HEXFET

- 1.- GATE
- 2.- DRAIN
- 3.- SOURCE

IGBTs - CoPACK

- 1.- GATE
- 2.- COLLECTOR
- 3.- EMITTER

DIODES

- 1.- ANODE/OPEN
- 2.- CATHODE
- 3.- ANODE

SYMBOL	DIMENSIONS				NOTES
	MILLIMETERS		INCHES		
	MIN.	MAX.	MIN.	MAX.	
A	3.56	4.82	.140	.190	
A1	0.51	1.40	.020	.055	
A2	2.04	2.92	.080	.115	
b	0.38	1.01	.015	.040	
b1	0.38	0.96	.015	.038	5
b2	1.15	1.77	.045	.070	
b3	1.15	1.73	.045	.068	
c	0.36	0.61	.014	.024	
c1	0.36	0.56	.014	.022	5
D	14.22	16.51	.560	.650	4
D1	8.38	9.02	.330	.355	
D2	12.19	12.88	.480	.507	7
E	9.66	10.66	.380	.420	4,7
E1	8.38	8.89	.330	.350	7
e	2.54 BSC		.100 BSC		
e1	5.08		.200 BSC		
H1	5.85	6.55	.230	.270	7,8
L	12.70	14.73	.500	.580	
L1	-	6.35	-	.250	3
øP	3.54	4.08	.139	.161	
Q	2.54	3.42	.100	.135	
ø	90°-93°		90°-93°		

TO-220AB Part Marking Information

EXAMPLE: THIS IS AN IRF1010
 LOT CODE 1789
 ASSEMBLED ON WW 19, 2000
 IN THE ASSEMBLY LINE "C"

Note: "P" in assembly line position indicates "Lead - Free"

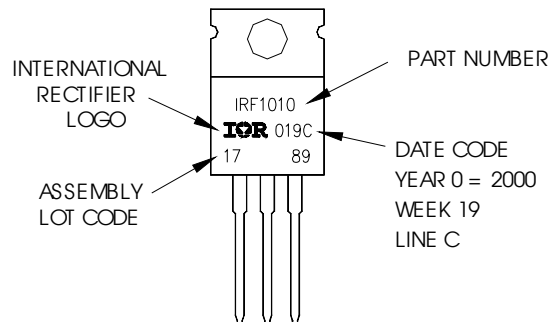

TO-220AB packages are not recommended for Surface Mount Application.

Data and specifications subject to change without notice.
 This product has been designed and qualified for the Consumer market.
 Qualification Standards can be found on IR's Web site.