



# STM32F101x6 STM32F101x8 STM32F101xB

Access line, advanced ARM-based 32-bit MCU with Flash memory, six 16-bit timers, ADC and seven communication interfaces

Preliminary Data

## Features

- Core: ARM 32-bit Cortex™-M3 CPU
  - 36 MHz, 45 DMIPS with 1.25 DMIPS/MHz
  - Single-cycle multiplication and hardware division
  - Nested interrupt controller with 43 maskable interrupt channels
  - Interrupt processing (down to 6 CPU cycles) with tail chaining
- Memories
  - 32-to-128 Kbytes of Flash memory
  - 6-to-16 Kbytes of SRAM
- Clock, reset and supply management
  - 2.0 to 3.6 V application supply and I/Os
  - POR, PDR and programmable voltage detector (PVD)
  - 4-to-16 MHz high-speed quartz oscillator
  - Internal 8 MHz factory-trimmed RC
  - Internal 32 kHz RC
  - PLL for CPU clock
  - Dedicated 32 kHz oscillator for RTC with calibration
- Low power
  - Sleep, Stop and Standby modes
  - V<sub>BAT</sub> supply for RTC and backup registers
- Debug mode
  - Serial wire debug (SWD) and JTAG interfaces
- DMA
  - 7-channel DMA controller
  - Peripherals supported: timers, ADC, SPIs, I<sup>2</sup>Cs and USARTs
- 12-bit, 1 μs A/D converter (16-channel)
  - Conversion range: 0 to 3.6 V

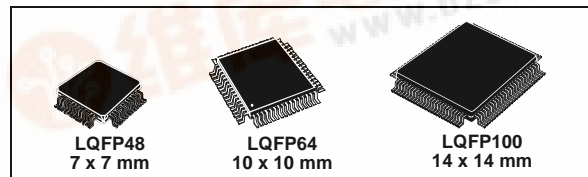

- Temperature sensor
- Up to 80 fast I/O ports
  - 32/49/80 5 V-tolerant I/Os
  - All mappable on 16 external interrupt vectors
  - Atomic read/modify/write operations
- Up to 6 timers
  - Up to three 16-bit timers, each with up to 4 IC/OC/PWM or pulse counter
  - 2 x 16-bit watchdog timers (Independent and Window)
  - SysTick timer: 24-bit downcounter
- Up to 7 communication interfaces
  - Up to 2 x I<sup>2</sup>C interfaces (SMBus/PMBus)
  - Up to 3 USARTs (ISO 7816 interface, LIN, IrDA capability, modem control)
  - Up to 2 SPIs (18 Mbit/s)

Table 1. Device summary

Reference	Root part number
STM32F101x6	STM32F101C6, STM32F101R6
STM32F101x8	STM32F101C8, STM32F101R8 STM32F101V8
STM32F101xB	STM32F101RB, STM32F101VB



# Contents

<b>1</b>	<b>Introduction</b> .....	<b>6</b>
<b>2</b>	<b>Description</b> .....	<b>6</b>
2.1	Device overview .....	7
2.2	Overview .....	8
<b>3</b>	<b>Pin descriptions</b> .....	<b>14</b>
<b>4</b>	<b>Memory mapping</b> .....	<b>20</b>
<b>5</b>	<b>Electrical characteristics</b> .....	<b>21</b>
5.1	Test conditions .....	21
5.1.1	Minimum and maximum values .....	21
5.1.2	Typical values .....	21
5.1.3	Typical curves .....	21
5.1.4	Loading capacitor .....	21
5.1.5	Pin input voltage .....	21
5.1.6	Power supply scheme .....	22
5.1.7	Current consumption measurement .....	23
5.2	Absolute maximum ratings .....	24
5.3	Operating conditions .....	26
5.3.1	General operating conditions .....	26
5.3.2	Operating conditions at power-up / power-down .....	26
5.3.3	Embedded reset and power control block characteristics .....	27
5.3.4	Embedded reference voltage .....	27
5.3.5	Supply current characteristics .....	28
5.3.6	External clock source characteristics .....	32
5.3.7	Internal Clock source characteristics .....	36
5.3.8	PLL characteristics .....	37
5.3.9	Memory characteristics .....	38
5.3.10	EMC characteristics .....	39
5.3.11	Absolute maximum ratings (electrical sensitivity) .....	40
5.3.12	I/O port characteristics .....	42
5.3.13	NRST pin characteristics .....	47



---

5.3.14	TIM timer characteristics .....	48
5.3.15	Communications interfaces .....	49
5.3.16	12-bit ADC characteristics .....	54
5.3.17	Temperature sensor characteristics .....	57
<b>6</b>	<b>Package characteristics .....</b>	<b>58</b>
6.1	Thermal characteristics .....	61
<b>7</b>	<b>Order codes .....</b>	<b>62</b>
7.1	Future family enhancements .....	62
<b>8</b>	<b>Revision history .....</b>	<b>63</b>



## List of tables

Table 1.	Device summary . . . . .	1
Table 2.	Device features and peripheral counts (STM32F101xx access line) . . . . .	7
Table 3.	Pin definitions . . . . .	16
Table 4.	Voltage characteristics . . . . .	24
Table 5.	Current characteristics . . . . .	24
Table 6.	Thermal characteristics . . . . .	25
Table 7.	General operating conditions . . . . .	26
Table 8.	Operating conditions at power-up / power-down . . . . .	26
Table 9.	Embedded reset and power control block characteristics . . . . .	27
Table 10.	Embedded internal reference voltage . . . . .	27
Table 11.	Maximum current consumption in Run and Sleep modes ( $T_A = 85\text{ }^\circ\text{C}$ ) . . . . .	28
Table 12.	Maximum current consumption in Stop and Standby modes . . . . .	29
Table 13.	Typical current consumption in Run and Sleep modes . . . . .	30
Table 14.	Typical current consumption in Stop and Standby modes . . . . .	31
Table 15.	High-speed user external (HSE) clock characteristics . . . . .	32
Table 16.	Low-speed user external clock characteristics . . . . .	32
Table 17.	HSE 4-16 MHz oscillator characteristics . . . . .	34
Table 18.	LSE oscillator characteristics ( $f_{LSE} = 32.768\text{ kHz}$ ) . . . . .	35
Table 19.	HSI oscillator characteristics . . . . .	36
Table 20.	LSI oscillator characteristics . . . . .	36
Table 21.	Low-power mode wakeup timings . . . . .	37
Table 22.	PLL characteristics . . . . .	37
Table 23.	Flash memory characteristics . . . . .	38
Table 24.	Flash endurance and data retention . . . . .	38
Table 25.	EMS characteristics . . . . .	39
Table 26.	EMI characteristics . . . . .	40
Table 27.	ESD absolute maximum ratings . . . . .	40
Table 28.	Electrical sensitivities . . . . .	41
Table 29.	I/O static characteristics . . . . .	42
Table 30.	Output voltage characteristics . . . . .	44
Table 31.	I/O AC characteristics . . . . .	45
Table 32.	NRST pin characteristics . . . . .	47
Table 33.	TIMx characteristics . . . . .	48
Table 34.	I <sup>2</sup> C characteristics . . . . .	49
Table 35.	SCL frequency ( $f_{PCLK1} = 36\text{ MHz}$ , $V_{DD} = 3.3\text{ V}$ ) . . . . .	50
Table 36.	SPI characteristics . . . . .	51
Table 37.	ADC characteristics . . . . .	54
Table 38.	ADC accuracy ( $f_{PCLK2} = 10\text{ MHz}$ , $f_{ADC} = 10\text{ MHz}$ , $R_{AIN} < 10\text{ k}\Omega$ , $V_{DDA} = 3.3\text{ V}$ ) . . . . .	55
Table 39.	TS characteristics . . . . .	57
Table 40.	LQPF100 – 100-pin low-profile quad flat package mechanical data . . . . .	58
Table 41.	LQFP64 – 64-pin low-profile quad flat package mechanical data . . . . .	59
Table 42.	LQFP48 – 48-pin low-profile quad flat package mechanical data . . . . .	60
Table 43.	Thermal characteristics . . . . .	61
Table 44.	Order codes . . . . .	62
Table 45.	Document revision history . . . . .	63



## List of figures

Figure 1.	STM32F101xx access line block diagram	13
Figure 2.	STM32F101xx access line LQFP100 pinout	14
Figure 3.	STM32F101xx access line LQFP64 pinout	15
Figure 4.	STM32F101xx access line LQFP48 pinout	15
Figure 5.	Memory map	20
Figure 6.	Pin loading conditions	22
Figure 7.	Pin input voltage	22
Figure 8.	Power supply scheme	22
Figure 9.	Current consumption measurement scheme	23
Figure 10.	High-speed external clock source AC timing diagram	33
Figure 11.	Low-speed external clock source AC timing diagram	33
Figure 12.	Typical application with an 8 MHz crystal	34
Figure 13.	Typical application with a 32.768 kHz crystal	35
Figure 14.	Unused I/O pin connection	43
Figure 15.	I/O AC characteristics definition	46
Figure 16.	Recommended NRST pin protection	47
Figure 17.	I <sup>2</sup> C bus AC waveforms and measurement circuit	50
Figure 18.	SPI timing diagram - slave mode and CPHA=0	52
Figure 19.	SPI timing diagram - slave mode and CPHA=11)	52
Figure 20.	SPI timing diagram - master mode	53
Figure 21.	ADC accuracy characteristics	55
Figure 22.	Typical connection diagram using the ADC	55
Figure 23.	Power supply and reference decoupling ( $V_{REF+}$ not connected to $V_{DDA}$ )	56
Figure 24.	Power supply and reference decoupling ( $V_{REF+}$ connected to $V_{DDA}$ )	56
Figure 25.	LQPF100 – 100-pin low-profile quad flat package outline	58
Figure 26.	LQFP64 – 64-pin low-profile quad flat package outline	59
Figure 27.	LQFP48 – 48-pin low-profile quad flat package outline	60



## 1 Introduction

This datasheet contains the description of the STM32F101xx access line family features, pinout, Electrical Characteristics, Mechanical Data and Ordering information.

For information on programming, erasing and protection of the internal Flash memory please refer to the *STM32F10x Flash Programming Reference Manual*

For information on the Cortex™-M3 core please refer to the Cortex™-M3 Technical Reference Manual.

## 2 Description

The STM32F101xx access line family incorporates the high-performance ARM Cortex™-M3 32-bit RISC core operating at a 36 MHz frequency, high-speed embedded memories (Flash memory up to 128Kbytes and SRAM up to 16 Kbytes), and an extensive range of enhanced peripherals and I/Os connected to two APB buses. All devices offer standard communication interfaces (two I<sup>2</sup>Cs, two SPIs, and up to three USARTs), one 12-bit ADC and three general purpose 16-bit timers.

The STM32F101 family operates in the -40 to +85°C temperature range, from a 2.0 to 3.6 V power supply. A comprehensive set of power-saving mode allows to design low-power applications.

The complete STM32F101xx access line family includes devices in 3 different package types: from 48 pins to 100 pins. Depending on the device chosen, different sets of peripherals are included, the description below gives an overview of the complete range of peripherals proposed in this family.

These features make the STM32F101xx access line microcontroller family suitable for a wide range of applications:

- Application control and user interface
- Medical and handheld equipment
- PC peripherals, gaming and GPS platforms
- Industrial applications: PLC, inverters, printers, and scanners
- Alarm systems, Video intercom, and HVAC

*Figure 1* shows the general block diagram of the device family.



## 2.1 Device overview

Table 2. Device features and peripheral counts (STM32F101xx access line)

Peripheral		STM32F101Cx		STM32F101Rx			STM32F101Vx	
Flash - Kbytes		32	64	32	64	128	64	128
SRAM - Kbytes		6	10	6	10	16	10	16
Timers	General purpose	2	3	3			3	
	Communication							
	SPI	1	2	1	2		2	
	I <sup>2</sup> C	1	2	1	2		2	
	USART	2	3	2	3		3	
12-bit synchronized ADC number of channels		1 10 channels		1 16 channels				
GPIOs		32		49			80	
CPU frequency		36 MHz						
Operating voltage		2.0 to 3.6 V						
Operating temperature		-40 to +85 °C						
Packages		LQFP48		LQFP64			LQFP100	



## 2.2 Overview

### ARM® Cortex™-M3 core with embedded Flash and SRAM

The ARM Cortex™-M3 processor is the latest generation of ARM processors for embedded systems. It has been developed to provide a low-cost platform that meets the needs of MCU implementation, with a reduced pin count and low-power consumption, while delivering outstanding computational performance and an advanced system response to interrupts.

The ARM Cortex™-M3 32-bit RISC processor features exceptional code-efficiency, delivering the high-performance expected from an ARM core in the memory size usually associated with 8- and 16-bit devices.

The STM32F101xx access line family having an embedded ARM core, is therefore compatible with all ARM tools and software.

### Embedded Flash memory

Up to 128 Kbytes of embedded Flash is available for storing programs and data.

### Embedded SRAM

Up to 16 Kbytes of embedded SRAM accessed (read/write) at CPU clock speed with 0 wait states.

### Nested vectored interrupt controller (NVIC)

The STM32F101xx access line embeds a nested vectored interrupt controller able to handle up to 43 maskable interrupt channels (not including the 16 interrupt lines of Cortex™-M3) and 16 priority levels.

- Closely coupled NVIC gives low latency interrupt processing
- Interrupt entry vector table address passed directly to the core
- Closely coupled NVIC core interface
- Allows early processing of interrupts
- Processing of *late arriving* higher priority interrupts
- Support for tail-chaining
- Processor state automatically saved
- Interrupt entry restored on interrupt exit with no instruction overhead

This hardware block provides flexible interrupt management features with minimal interrupt latency.





## External interrupt/event controller (EXTI)

The external interrupt/event controller consists of 19 edge detectors lines used to generate interrupt/event requests. Each line can be independently configured to select the trigger event (rising edge, falling edge, both) and can be masked independently. A pending register maintains the status of the interrupt requests. The EXTI can detect external line with pulse width lower than the Internal APB2 clock period. Up to 80 GPIOs are connected to the 16 external interrupt lines.

## Clocks and startup

System clock selection is performed on startup, however the internal RC 8 MHz oscillator is selected as default CPU clock on reset. An external 4-16 MHz clock can be selected and is monitored for failure. During such a scenario, it is disabled and software interrupt management follows. Similarly, full interrupt management of the PLL clock entry is available when necessary (for example with failure of an indirectly used external oscillator).

Several prescalers allow the configuration of the AHB frequency, the High Speed APB (APB2) and the low Speed APB (APB1) domains. The maximum frequency of the AHB and the APB domains is 36 MHz.

## Boot modes

At startup, boot pins are used to select one of five boot options:

- Boot from User Flash
- Boot from System Memory
- Boot from SRAM

The boot loader is located in System Memory. It is used to reprogram the Flash memory by using the USART.

## Power supply schemes

- $V_{DD} = 2.0$  to  $3.6$  V: External power supply for I/Os and the internal regulator. Provided externally through  $V_{DD}$  pins.
- $V_{SSA}$ ,  $V_{DDA} = 2.0$  to  $3.6$  V: External analog power supplies for ADC, Reset blocks, RCs and PLL. In  $V_{DD}$  range (ADC is limited at  $2.4$  V).
- $V_{BAT} = 1.8$  to  $3.6$  V: Power supply for RTC, external clock 32 kHz oscillator and backup registers (through power switch) when  $V_{DD}$  is not present.

## Power supply supervisor

The device has an integrated power on reset (POR)/power down reset (PDR) circuitry. It is always active, and ensures proper operation starting from/down to 2 V. The device remains in reset mode when  $V_{DD}$  is below a specified threshold,  $V_{POR/PDR}$ , without the need for an external reset circuit.

The device features an embedded Programmable voltage detector (PVD) that monitors the  $V_{DD}$  power supply and compares it to the  $V_{PVD}$  threshold. An interrupt can be generated when  $V_{DD}$  drops below the  $V_{PVD}$  and/or when  $V_{DD}$  is higher than the  $V_{PVD}$  threshold. The interrupt service routine can then generate a warning message and/or put the MCU into a safe state. The PVD is enabled by software.

Refer to [Table 9: Embedded reset and power control block characteristics](#) for the values of  $V_{POR/PDR}$  and  $V_{PVD}$ .



### Voltage regulator

The regulator has three operation modes: main (MR), low power (LPR) and power down.

- MR is used in the nominal regulation mode (Run)
- LPR is used in the Stop modes
- Power down is used in Standby Mode: the regulator output is in high impedance: the kernel circuitry is powered-down, inducing zero consumption (but the contents of the registers and SRAM are lost)

This regulator is always enabled after RESET. It is disabled in Standby Mode, providing high impedance output.

### Low-power modes

The STM32F101xx access line supports three low-power modes to achieve the best compromise between low power consumption, short startup time and available wakeup sources:

- **Sleep mode**  
In Sleep mode, only the CPU is stopped. All peripherals continue to operate and can wake up the CPU when an interrupt/event occurs.
- **Stop mode**  
Stop mode allows to achieve the lowest power consumption while retaining the content of SRAM and registers. All clocks in the 1.8 V domain are stopped, the PLL, the HSI and the HSE RC oscillators are disabled. The voltage regulator can also be put either in normal or in low power mode.  
The device can be woken up from Stop mode by any of the EXTI line. The EXTI line source can be one of the 16 external lines, the PVD output or the RTC alarm.
- **Standby mode**  
The Standby mode allows to achieve the lowest power consumption. The internal voltage regulator is switched off so that the entire 1.8 V domain is powered off. The PLL, the HSI and the HSE RC oscillators are also switched off. After entering Standby mode, SRAM and registers content are lost except for registers in the Backup domain and Standby circuitry.  
The device exits Standby mode when an external reset (NRST pin), a IWDG reset, a rising edge on the WKUP pin, or an RTC alarm occurs.

*Note: The RTC, the IWDG, and the corresponding clock sources are not stopped by entering Stop or Standby mode.*

### DMA

The flexible 7-channel general-purpose DMA is able to manage memory-to-memory, peripheral-to-memory and memory-to-peripheral transfers. The DMA controller supports circular buffer management avoiding the generation of interrupts when the controller reaches the end of the buffer.

Each channel is connected to dedicated hardware DMA requests, with support for software trigger on each channel. Configuration is made by software and transfer sizes between source and destination are independent.

The DMA can be used with the main peripherals: SPI, I<sup>2</sup>C, USART, general purpose timers TIMx and ADC.



### RTC (real-time clock) and backup registers

The RTC and the backup registers are supplied through a switch that takes power either on  $V_{DD}$  supply when present or through the  $V_{BAT}$  pin. The backup registers (ten 16-bit registers) can be used to store data when  $V_{DD}$  power is not present.

The Real-Time Clock provides a set of continuously running counters which can be used with suitable software to provide a clock calendar function, and provides an alarm interrupt and a periodic interrupt. It is clocked by an external 32.768 kHz oscillator, the internal low power RC oscillator or the high-speed external clock divided by 128. The internal low power RC has a typical frequency of 32 kHz. The RTC can be calibrated using an external 512Hz output to compensate for any natural quartz deviation. The RTC features a 32-bit programmable counter for long term measurement using the Compare register to generate an alarm. A 20-bit prescaler is used for the time base clock and is by default configured to generate a time base of 1 second from a clock at 32.768 kHz.

### Independent watchdog

The independent watchdog is based on a 12-bit downcounter and 8-bit prescaler. It is clocked from an independent 32 kHz internal RC and as it operates independently from the main clock, it can operate in Stop and Standby modes. It can be used as a watchdog to reset the device when a problem occurs, or as a free running timer for application time out management. It is hardware or software configurable through the option bytes. The counter can be frozen in debug mode.

### Window watchdog

The window watchdog is based on a 7-bit downcounter that can be set as free running. It can be used as a watchdog to reset the device when a problem occurs. It is clocked from the main clock. It has an early warning interrupt capability and the counter can be frozen in debug mode.

### SysTick timer

This timer is dedicated for OS, but could also be used as a standard down counter. It features:

- A 24-bit down counter
- Autoreload capability
- Maskable system interrupt generation when the counter reaches 0.
- Programmable clock source

### General purpose timers (TIMx)

There are up to 3 synchronizable standard timers embedded in the STM32F101xx access line devices. These timers are based on a 16-bit auto-reload up/down counter, a 16-bit prescaler and feature 4 independent channels each for input capture, output compare, PWM or one pulse mode output. This gives up to 12 input captures / output compares / PWMs on the largest packages. They can work together via the Timer Link feature for synchronization or event chaining.

The counter can be frozen in debug mode.

Any of the standard timers can be used to generate PWM outputs. Each of the timers has independent DMA request generations.



### I<sup>2</sup>C bus

Up to two I<sup>2</sup>C bus interfaces can operate in multi-master and slave modes. They can support standard and fast modes.

They support dual slave addressing (7-bit only) and both 7/10-bit addressing in master mode. A hardware CRC generation/verification is embedded.

They can be served by DMA and they support SM Bus 2.0/PM Bus.

### Universal synchronous/asynchronous receiver transmitter (USART)

The available USART interfaces communicate at up to 2.25 Mbit/s. They provide hardware management of the CTS and RTS signals, support IrDA SIR ENDEC, are ISO 7816 compliant and have LIN Master/Slave capability.

The USART interfaces can be served by the DMA controller.

### Serial peripheral interface (SPI)

Up to two SPIs are able to communicate up to 18 Mbits/s in slave and master modes in full-duplex and simplex communication modes. The 3-bit prescaler gives 8 master mode frequencies and the frame is configurable from 8-bit to 16-bit. The hardware CRC generation/verification supports basic SD Card/MMC modes.

Both SPIs can be served by the DMA controller.

### GPIOs (general purpose inputs/outputs)

Each of the GPIO pins can be configured by software as output (push-pull or open-drain), as input (with or without pull-up or pull-down) or as Peripheral Alternate Function. Most of the GPIO pins are shared with digital or analog alternate functions. All GPIOs are high current-capable.

The I/Os alternate function configuration can be locked if needed following a specific sequence in order to avoid spurious writing to the I/Os registers.

### ADC (analog to digital converter)

The 12-bit Analog to Digital Converter has up to 16 external channels and performs conversions in single-shot or scan modes. In scan mode, automatic conversion is performed on a selected group of analog inputs.

The ADC can be served by the DMA controller.

An analog watchdog feature allows very precise monitoring of the converted voltage of one, some or all selected channels. An interrupt is generated when the converted voltage is outside the programmed thresholds.

### Temperature sensor

The temperature sensor has to generate a linear voltage with any variation in temperature. The conversion range is between  $2V < V_{DDA} < 3.6V$ . The temperature sensor is internally connected to the ADC\_IN16 input channel which is used to convert the sensor output voltage into a digital value.



### Serial wire JTAG debug port (SWJ-DP)

The ARM SWJ-DP Interface is embedded, and is a combined JTAG and serial wire debug port that enables either a serial wire debug or a JTAG probe to be connected to the target. The JTAG TMS and TCK pins are shared respectively with SWDIO and SWCLK and a specific sequence on the TMS pin is used to switch between JTAG-DP and SW-DP.

Figure 1. STM32F101xx access line block diagram

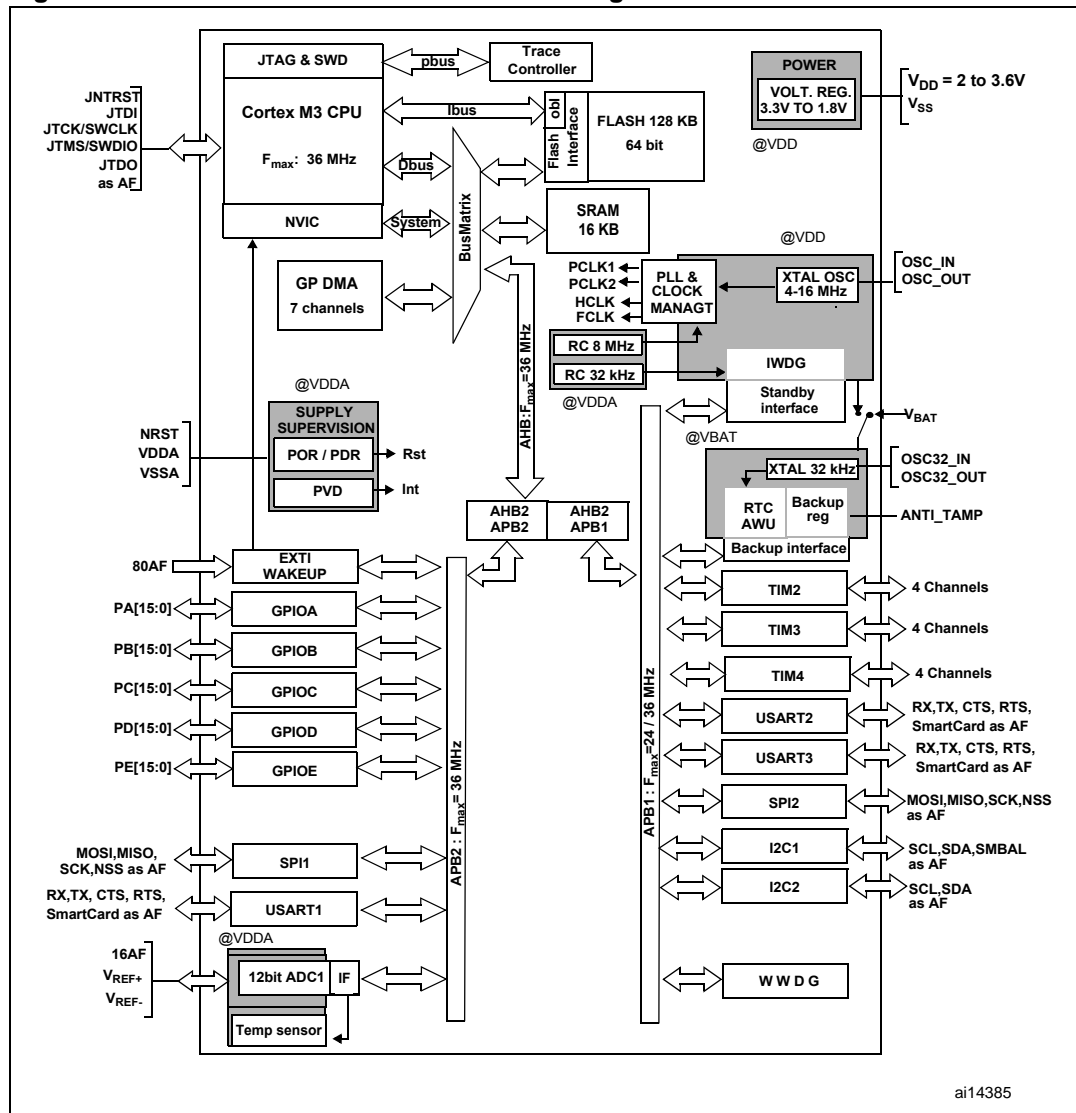

1. AF = alternate function on I/O port pin.
2. TA = -40 °C to +85 °C (junction temperature up to 125 °C).

### 3 Pin descriptions

Figure 2. STM32F101xx access line LQFP100 pinout

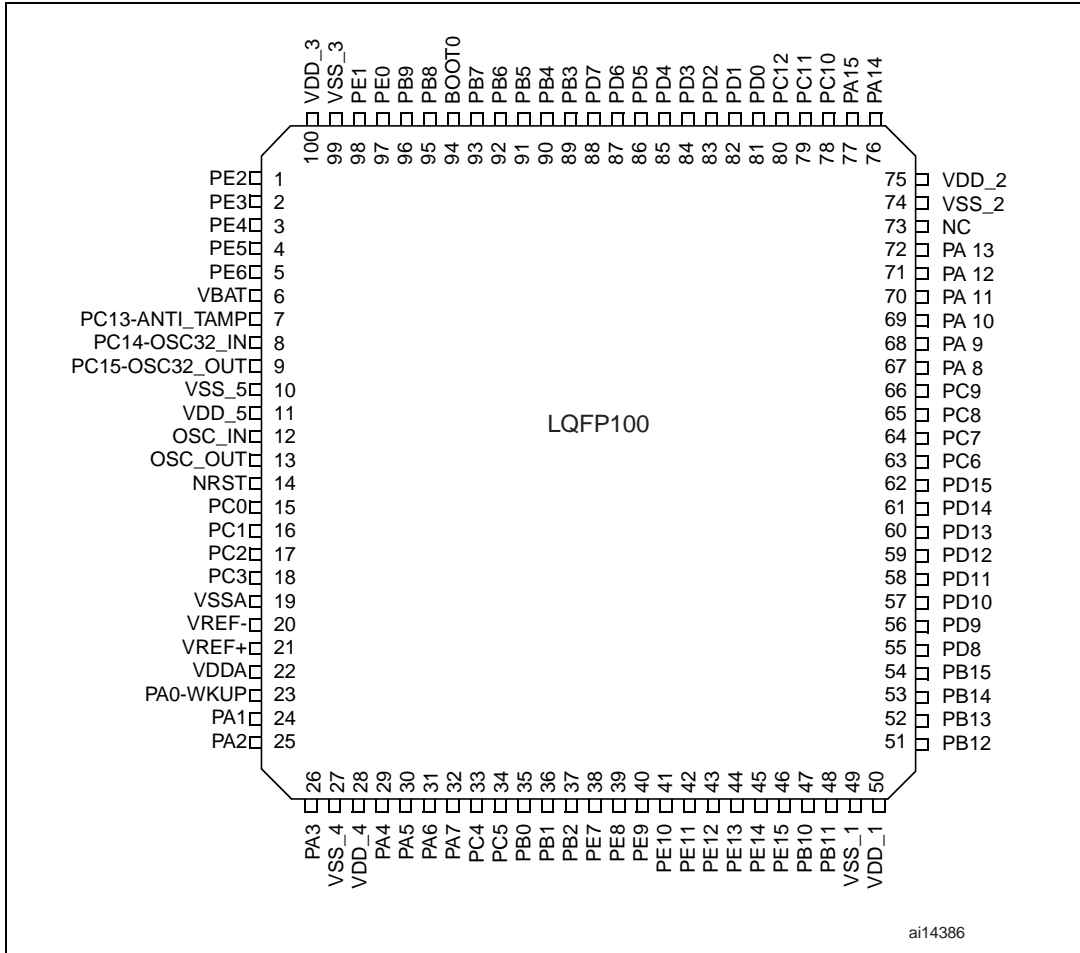

Figure 3. STM32F101xx access line LQFP64 pinout

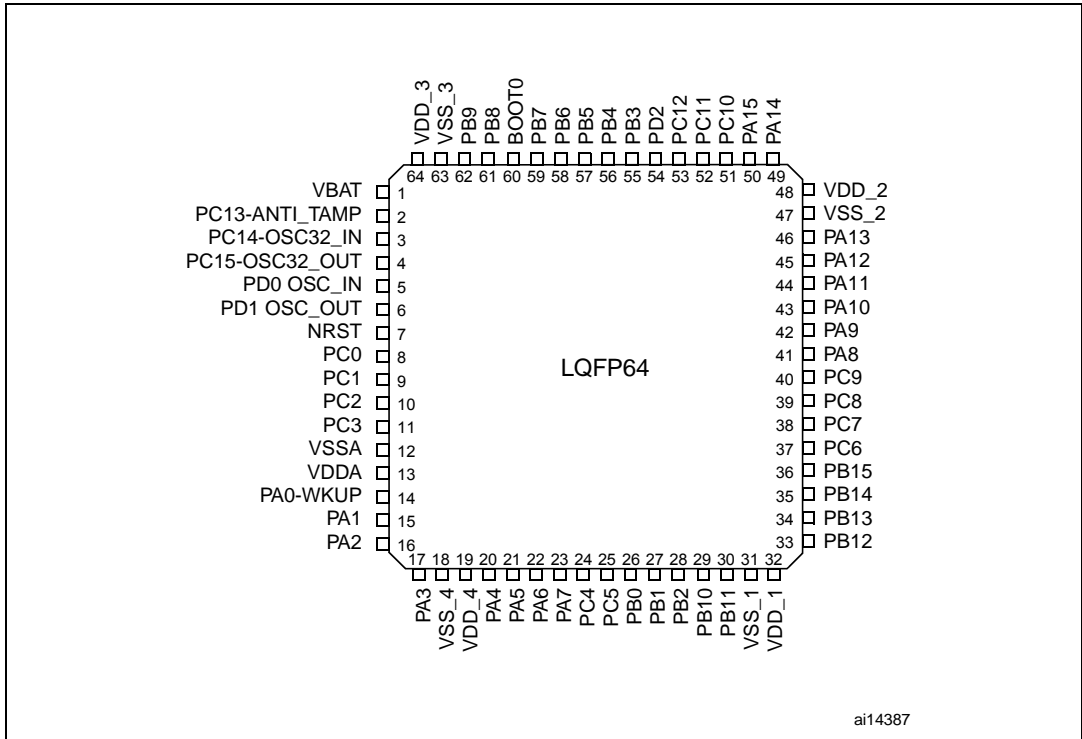

Figure 4. STM32F101xx access line LQFP48 pinout

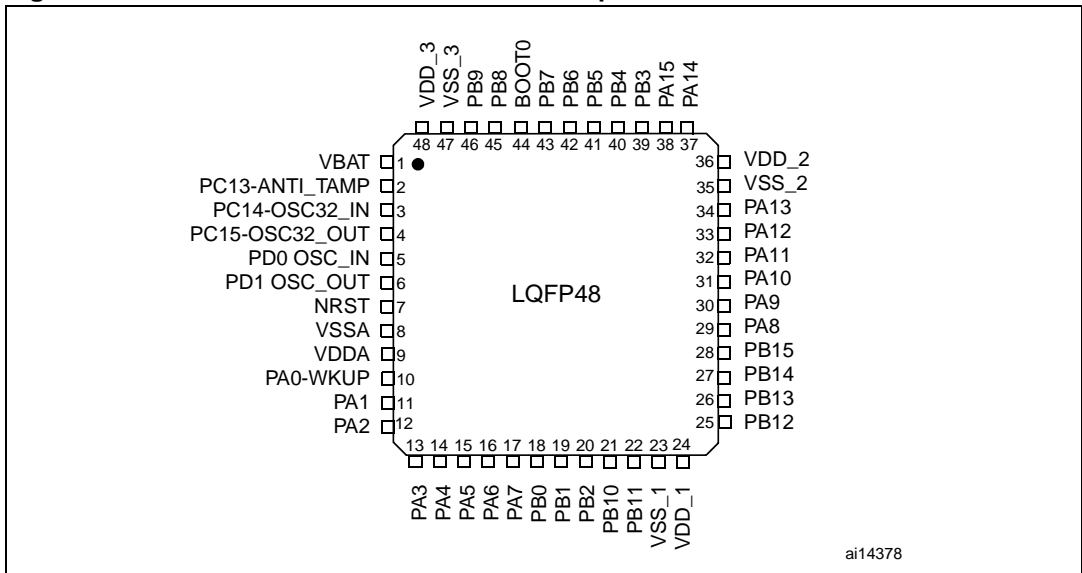

Table 3. Pin definitions

Pins			Pin name	Type <sup>(1)</sup>	I/O level <sup>(2)</sup>	Main function <sup>(3)</sup> (after reset)	Default alternate functions <sup>(3)</sup>
LQFP48	LQFP64	LQFP100					
-	-	1	PE2/TRACECK	I/O	FT	PE2	TRACECK
-	-	2	PE3/TRACED0	I/O	FT	PE3	TRACED0
-	-	3	PE4/TRACED1	I/O	FT	PE4	TRACED1
-	-	4	PE5/TRACED2	I/O	FT	PE5	TRACED2
-	-	5	PE6/TRACED3	I/O	FT	PE6	TRACED3
1	1	6	V <sub>BAT</sub>	S		V <sub>BAT</sub>	
2	2	7	PC13-ANTI_TAMP <sup>(4)</sup>	I/O		PC13	ANTI_TAMP
3	3	8	PC14-OSC32_IN <sup>(4)</sup>	I/O		PC14- OSC32_IN	
4	4	9	PC15-OSC32_OUT <sup>(4)</sup>	I/O		PC15- OSC32_OUT	
-	-	10	V <sub>SS_5</sub>	S		V <sub>SS_5</sub>	
-	-	11	V <sub>DD_5</sub>	S		V <sub>DD_5</sub>	
5	5	12	OSC_IN	I		OSC_IN	
6	6	13	OSC_OUT	O		OSC_OUT	
7	7	14	NRST	I/O		NRST	
-	8	15	PC0/ADC_IN10	I/O		PC0	ADC_IN10
-	9	16	PC1/ADC_IN11	I/O		PC1	ADC_IN11
-	10	17	PC2/ADC_IN12	I/O		PC2	ADC_IN12
-	11	18	PC3/ADC_IN13	I/O		PC3	ADC_IN13
8	12	19	V <sub>SSA</sub>	S		V <sub>SSA</sub>	
-	-	20	VREF-	S		VREF-	
-	-	21	VREF+	S		VREF+	
9	13	22	V <sub>DDA</sub>	S		V <sub>DDA</sub>	
10	14	23	PA0-WKUP/USART2_CTS/ ADC_IN0/TIM2_CH1_ETR	I/O		PA0	WKUP/USART2_CTS <sup>(7)</sup> / ADC_IN0/ TIM2_CH1_ETR <sup>(7)</sup>
11	15	24	PA1/USART2_RTS/ADC_ IN1/TIM2_CH2	I/O		PA1	USART2_RTS <sup>(7)</sup> /ADC_IN1/ TIM2_CH2 <sup>(7)</sup>
12	16	25	PA2/USART2_TX/ADC_IN2/ TIM2_CH3	I/O		PA2	USART2_TX <sup>(7)</sup> /ADC_IN2/ TIM2_CH3 <sup>(7)</sup>
13	17	26	PA3/USART2_RX/ADC_IN3/ TIM2_CH4	I/O		PA3	USART2_RX <sup>(7)</sup> /ADC_IN3/ TIM2_CH4 <sup>(7)</sup>
-	18	27	V <sub>SS_4</sub>	S		V <sub>SS_4</sub>	
-	19	28	V <sub>DD_4</sub>	S		V <sub>DD_4</sub>	





Table 3. Pin definitions (continued)

Pins			Pin name	Type <sup>(1)</sup>	I/O level <sup>(2)</sup>	Main function <sup>(3)</sup> (after reset)	Default alternate functions <sup>(3)</sup>
LQFP48	LQFP64	LQFP100					
14	20	29	PA4/SPI1_NSS/ USART2_CK/ADC_IN4	I/O		PA4	SPI1_NSS/USART2_CK <sup>(7)</sup> / ADC_IN4
15	21	30	PA5/SPI1_SCK/ADC_IN5	I/O		PA5	SPI1_SCK/ADC_IN5
16	22	31	PA6/SPI1_MISO/ADC_IN6/ TIM3_CH1	I/O		PA6	SPI1_MISO/ADC_IN6/ TIM3_CH1 <sup>(7)</sup>
17	23	32	PA7/SPI1_MOSI/ADC_IN7/ TIM3_CH2	I/O		PA7	SPI1_MOSI/ADC_IN7/ TIM3_CH2 <sup>(7)</sup>
-	24	33	PC4/ADC_IN14	I/O		PC4	ADC_IN14
-	25	34	PC5/ADC_IN15	I/O		PC5	ADC_IN15
18	26	35	PB0/ADC_IN8/TIM3_CH3	I/O		PB0	ADC_IN8/TIM3_CH3 <sup>(7)</sup>
19	27	36	PB1/ADC_IN9/TIM3_CH4	I/O		PB1	ADC_IN9/TIM3_CH4 <sup>(7)</sup>
20	28	37	PB2/BOOT1	I/O	FT	PB2/BOOT1	
-	-	38	PE7	I/O	FT	PE7	
-	-	39	PE8	I/O	FT	PE8	
-	-	40	PE9	I/O	FT	PE9	
-	-	41	PE10	I/O	FT	PE10	
-	-	42	PE11	I/O	FT	PE11	
-	-	43	PE12	I/O	FT	PE12	
-	-	44	PE13	I/O	FT	PE13	
-	-	45	PE14	I/O	FT	PE14	
-	-	46	PE15	I/O	FT	PE15	
21	29	47	PB10/I2C2_SCL USART3_TX	I/O	FT	PB10	I2C2_SCL <sup>(5)</sup> /USART3_TX <sup>(5)</sup> (7)
22	30	48	PB11/I2C2_SDA USART3_RX	I/O	FT	PB11	I2C2_SDA <sup>(5)</sup> /USART3_RX <sup>(5)</sup> (7)
23	31	49	V <sub>SS_1</sub>	S		V <sub>SS_1</sub>	
24	32	50	V <sub>DD_1</sub>	S		V <sub>DD_1</sub>	
25	33	51	PB12/SPI2_NSS/ I2C2_SMBAL/USART3_CK	I/O	FT	PB12	SPI2_NSS <sup>(5)</sup> (7)/I2C2_SMBAL <sup>(5)</sup> / USART3_CK <sup>(5)</sup> (7)
26	34	52	PB13/SPI2_SCK/ USART3_CTS	I/O	FT	PB13	SPI2_SCK <sup>(5)</sup> (7)/USART3_CTS <sup>(5)</sup> (7)
27	35	53	PB14/SPI2_MISO/ USART3_RTS	I/O	FT	PB14	SPI2_MISO <sup>(5)</sup> (7)/USART3_RTS <sup>(5)</sup> (7)
28	36	54	PB15/SPI2_MOSI	I/O	FT	PB15	SPI2_MOSI <sup>(5)</sup> (7)
-	-	55	PD8	I/O	FT	PD8	



Table 3. Pin definitions (continued)

Pins			Pin name	Type <sup>(1)</sup>	I/O level <sup>(2)</sup>	Main function <sup>(3)</sup> (after reset)	Default alternate functions <sup>(3)</sup>	
LQFP48	LQFP64	LQFP100						
-	-	56	PD9	I/O	FT	PD9		
-	-	57	PD10	I/O	FT	PD10		
-	-	58	PD11	I/O	FT	PD11		
-	-	59	PD12	I/O	FT	PD12		
-	-	60	PD13	I/O	FT	PD13		
-	-	61	PD14	I/O	FT	PD14		
-	-	62	PD15	I/O	FT	PD15		
-	37	63	PC6	I/O	FT	PC6		
	38	64	PC7	I/O	FT	PC7		
	39	65	PC8	I/O	FT	PC8		
-	40	66	PC9	I/O	FT	PC9		
29	41	67	PA8/USART1_CK/MCO	I/O	FT	PA8	USART1_CK/MCO	
30	42	68	PA9/USART1_TX	I/O	FT	PA9	USART1_TX <sup>(7)</sup>	
31	43	69	PA10/USART1_RX	I/O	FT	PA10	USART1_RX <sup>(7)</sup>	
32	44	70	PA11/USART1_CTS	I/O	FT	PA11	USART1_CTS	
33	45	71	PA12/USART1_RTS	I/O	FT	PA12	USART1_RTS	
34	46	72	PA13/JTMS/SWDIO	I/O	FT	JTMS-SWDIO	PA13	
-	-	73	Not connected					
35	47	74	V <sub>SS_2</sub>	S		V <sub>SS_2</sub>		
36	48	75	V <sub>DD_2</sub>	S		V <sub>DD_2</sub>		
37	49	76	PA14/JTCK/SWCLK	I/O	FT	JTCK/SWCLK	PA14	
38	50	77	PA15/JTDI	I/O	FT	JTDI	PA15	
-	51	78	PC10	I/O	FT	PC10		
-	52	79	PC11	I/O	FT	PC11		
-	53	80	PC12	I/O	FT	PC12		
5	5	81	PD0	I/O	FT	OSC_IN <sup>(6)</sup>		
6	6	82	PD1	I/O	FT	OSC_OUT <sup>(6)</sup>		
	54	83	PD2/TIM3_ETR	I/O	FT	PD2	TIM3_ETR	
-	-	84	PD3	I/O	FT	PD3		
-	-	85	PD4	I/O	FT	PD4		
-	-	86	PD5	I/O	FT	PD5		
-	-	87	PD6	I/O	FT	PD6		



Table 3. Pin definitions (continued)

Pins			Pin name	Type <sup>(1)</sup>	I/O level <sup>(2)</sup>	Main function <sup>(3)</sup> (after reset)	Default alternate functions <sup>(3)</sup>
LQFP48	LQFP64	LQFP100					
-	-	88	PD7	I/O	FT	PD7	
39	55	89	PB3/JTDO/TRACESWO	I/O	FT	JTDO	PB3/TRACESWO
40	56	90	PB4/JNTRST	I/O	FT	JNTRST	PB4
41	57	91	PB5/I2C1_SMBAL	I/O		PB5	I2C1_SMBAL
42	58	92	PB6/I2C1_SCL/TIM4_CH1	I/O	FT	PB6	I2C1_SCL <sup>(7)</sup> /TIM4_CH1 <sup>(5) (7)</sup>
43	59	93	PB7/I2C1_SDA/TIM4_CH2	I/O	FT	PB7	I2C1_SDA <sup>(7)</sup> /TIM4_CH2 <sup>(5) (7)</sup>
44	60	94	BOOT0	I		BOOT0	
45	61	95	PB8/TIM4_CH3	I/O	FT	PB8	TIM4_CH3 <sup>(5) (7)</sup>
46	62	96	PB9/TIM4_CH4	I/O	FT	PB9	TIM4_CH4 <sup>(5) (7)</sup>
-	-	97	PE0/TIM4_ETR	I/O	FT	PE0	TIM4_ETR <sup>(5)</sup>
-	-	98	PE1	I/O	FT	PE1	
47	63	99	V <sub>SS_3</sub>	S		V <sub>SS_3</sub>	
48	64	100	V <sub>DD_3</sub>	S		V <sub>DD_3</sub>	

1. I = input, O = output, S = supply, HiZ= high impedance.

2. FT= 5 V tolerant.

3. Function availability depends on the chosen device. Refer to Table 2 on page 7.

4. PC13, PC14 and PC15 are supplied through the power switch, and so their use in output mode is limited: they can be used only in output 2 MHz mode with a maximum load of 30 pF and only one pin can be put in output mode at a time.

5. Available only on devices with a Flash memory density equal or higher than 64 Kbytes.

6. For the LQFP48 and LQFP64 packages, the pins number 5 and 6 are configured as OSC\_IN/OSC\_OUT after reset, however the functionality of PD0 and PD1 can be remapped by software on these pins.

7. This alternate function can be remapped by software to some other port pins (if available on the used package). For more details, refer to the Alternate function I/O and debug configuration section in the STM32F10xxx reference manual, UM0306, available from the STMicroelectronics website: [www.st.com](http://www.st.com).





## 5 Electrical characteristics

### 5.1 Test conditions

Unless otherwise specified, all voltages are referred to  $V_{SS}$ .

#### 5.1.1 Minimum and maximum values

Unless otherwise specified the minimum and maximum values are guaranteed in the worst conditions of ambient temperature, supply voltage and frequencies by tests in production on 100% of the devices with an ambient temperature at  $T_A = 25\text{ °C}$  and  $T_A = T_{Amax}$  (given by the selected temperature range).

Data based on characterization results, design simulation and/or technology characteristics are indicated in the table footnotes and are not tested in production. Based on characterization, the minimum and maximum values refer to sample tests and represent the mean value plus or minus three times the standard deviation ( $\text{mean} \pm 3\Sigma$ ).

#### 5.1.2 Typical values

Unless otherwise specified, typical data are based on  $T_A = 25\text{ °C}$ ,  $V_{DD} = 3.3\text{ V}$  (for the  $2\text{ V} \leq V_{DD} \leq 3.6\text{ V}$  voltage range). They are given only as design guidelines and are not tested.

Typical ADC accuracy values are determined by characterization of a batch of samples from a standard diffusion lot over the full temperature range, where 95% of the devices have an error less than or equal to the value indicated ( $\text{mean} \pm 2\Sigma$ ).

#### 5.1.3 Typical curves

Unless otherwise specified, all typical curves are given only as design guidelines and are not tested.

#### 5.1.4 Loading capacitor

The loading conditions used for pin parameter measurement are shown in [Figure 6](#).

#### 5.1.5 Pin input voltage

The input voltage measurement on a pin of the device is described in [Figure 7](#).



Figure 6. Pin loading conditions

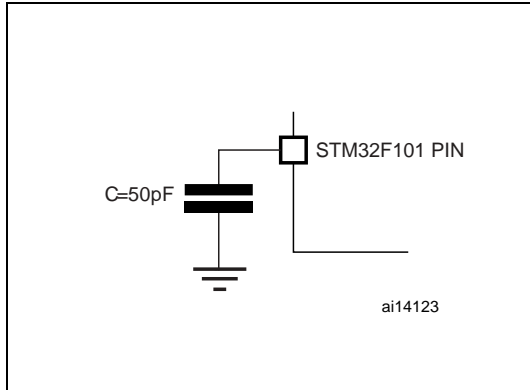
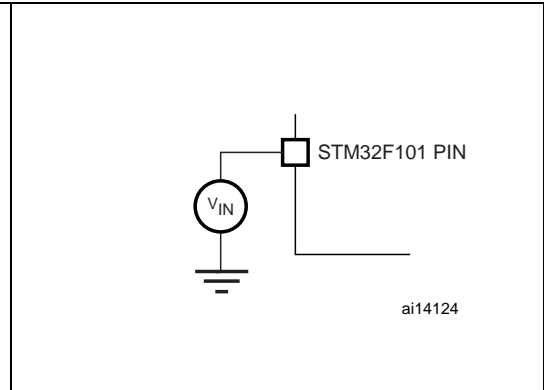
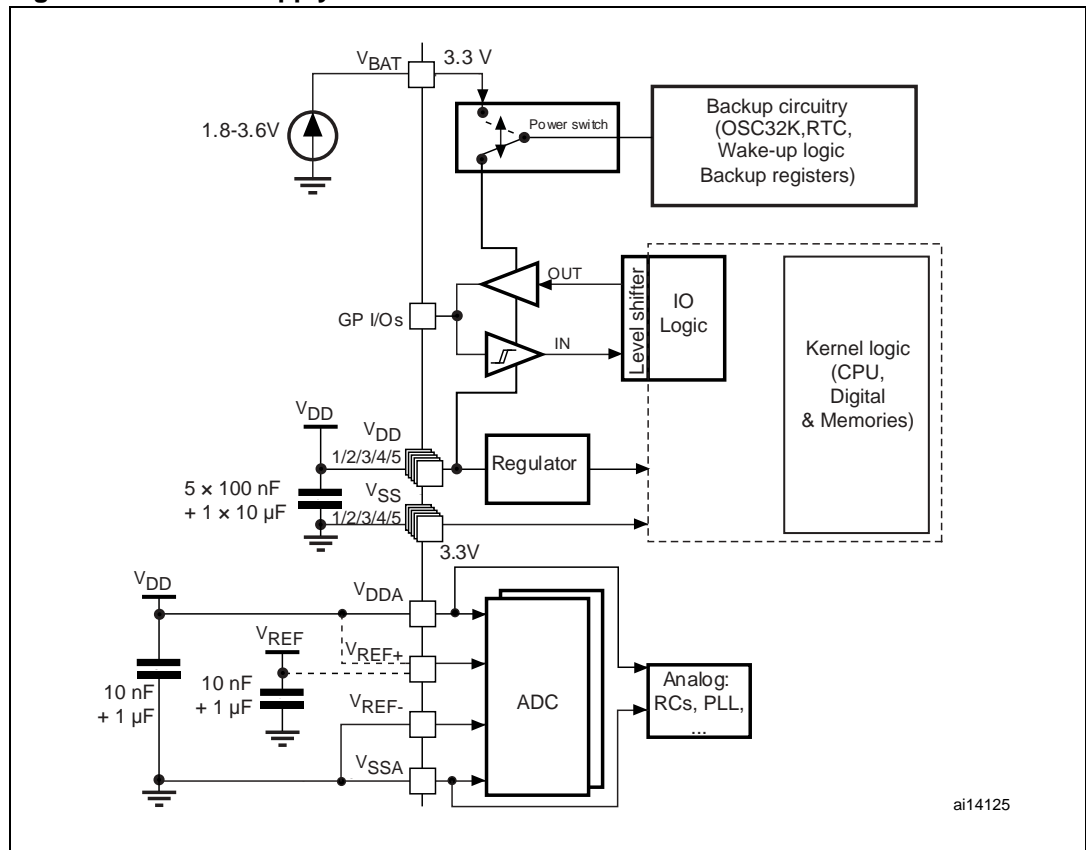

Figure 7. Pin input voltage



### 5.1.6 Power supply scheme

Figure 8. Power supply scheme



### 5.1.7 Current consumption measurement

Figure 9. Current consumption measurement scheme

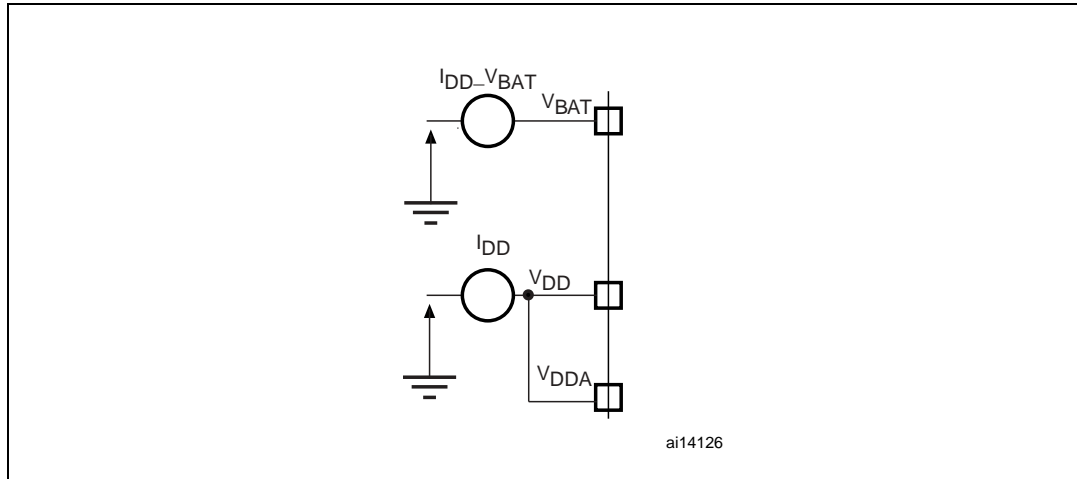

## 5.2 Absolute maximum ratings

Stresses above the absolute maximum ratings listed in [Table 4: Voltage characteristics](#), [Table 5: Current characteristics](#), and [Table 6: Thermal characteristics](#) may cause permanent damage to the device. These are stress ratings only and functional operation of the device at these conditions is not implied. Exposure to maximum rating conditions for extended periods may affect device reliability.

**Table 4. Voltage characteristics**

Symbol	Ratings	Min	Max	Unit
$V_{DD}-V_{SS}$	External 3.3 V supply voltage (including $V_{DDA}$ and $V_{DD}$ ) <sup>(1)</sup>	-0.3	4.0	V
$V_{IN}$	Input voltage on five volt tolerant pin <sup>(2)</sup>	$V_{SS}-0.3$	+5.5	
	Input voltage on any other pin <sup>(2)</sup>	$V_{SS}-0.3$	$V_{DD}+0.3$	
$ \Delta V_{DDx} $	Variations between different power pins	50	50	mV
$ V_{SSx}-V_{SS} $	Variations between all the different ground pins	50	50	
$V_{ESD(HBM)}$	Electrostatic discharge voltage (human body model)	see <a href="#">Section 5.3.11: Absolute maximum ratings (electrical sensitivity)</a>		

- All 3.3 V power ( $V_{DD}$ ,  $V_{DDA}$ ) and ground ( $V_{SS}$ ,  $V_{SSA}$ ) pins must always be connected to the external 3.3 V supply.
- $I_{INJ(PIN)}$  must never be exceeded (see [Table 5: Current characteristics](#)). This is implicitly insured if  $V_{IN}$  maximum is respected. If  $V_{IN}$  maximum cannot be respected, the injection current must be limited externally to the  $I_{INJ(PIN)}$  value. A positive injection is induced by  $V_{IN}>V_{DD}$  while a negative injection is induced by  $V_{IN}<V_{SS}$ .

**Table 5. Current characteristics**

Symbol	Ratings	Max.	Unit
$I_{VDD}$	Total current into $V_{DD}$ power lines (source) <sup>(1)</sup>	150	mA
$I_{VSS}$	Total current out of $V_{SS}$ ground lines (sink) <sup>(1)</sup>	150	
$I_{IO}$	Output current sunk by any I/O and control pin	25	
	Output current source by any I/Os and control pin	-25	
$I_{INJ(PIN)}$ <sup>(2)(3)</sup>	Injected current on NRST pin	± 5	
	Injected current on High-speed external OSC_IN and Low-speed external OSC_IN pins	± 5	
	Injected current on any other pin <sup>(4)</sup>	± 5	
$\Sigma I_{INJ(PIN)}$ <sup>(2)</sup>	Total injected current (sum of all I/O and control pins) <sup>(4)</sup>	± 25	

- All 3.3 V power ( $V_{DD}$ ,  $V_{DDA}$ ) and ground ( $V_{SS}$ ,  $V_{SSA}$ ) pins must always be connected to the external 3.3 V supply.
- $I_{INJ(PIN)}$  must never be exceeded. This is implicitly insured if  $V_{IN}$  maximum is respected. If  $V_{IN}$  maximum cannot be respected, the injection current must be limited externally to the  $I_{INJ(PIN)}$  value. A positive injection is induced by  $V_{IN}>V_{DD}$  while a negative injection is induced by  $V_{IN}<V_{SS}$ .
- Negative injection disturbs the analog performance of the device. See note in [Section 5.3.16: 12-bit ADC characteristics](#).
- When several inputs are submitted to a current injection, the maximum  $\Sigma I_{INJ(PIN)}$  is the absolute sum of the positive and negative injected currents (instantaneous values). These results are based on characterization with  $\Sigma I_{INJ(PIN)}$  maximum current injection on four I/O port pins of the device.





**Table 6. Thermal characteristics**

Symbol	Ratings	Value	Unit
$T_{STG}$	Storage temperature range	-65 to +150	°C
$T_J$	Maximum junction temperature (see Thermal characteristics)		



## 5.3 Operating conditions

### 5.3.1 General operating conditions

**Table 7. General operating conditions**

Symbol	Parameter	Conditions	Min	Max	Unit
$f_{\text{HCLK}}$	Internal AHB clock frequency		0	36	MHz
$f_{\text{PCLK1}}$	Internal APB1 clock frequency		0	36	
$f_{\text{PCLK2}}$	Internal APB2 clock frequency		0	36	
$V_{\text{DD}}$	Standard operating voltage		2	3.6	V
$V_{\text{BAT}}$	Backup operating voltage		1.8	3.6	V
$T_{\text{A}}$	Ambient temperature range		-40	85	°C

### 5.3.2 Operating conditions at power-up / power-down

The parameters given in [Table 8](#) are derived from tests performed under the ambient temperature condition summarized in [Table 7](#).

**Table 8. Operating conditions at power-up / power-down**

Symbol	Parameter	Conditions	Min	Typ	Max	Unit
$t_{\text{VDD}}$	$V_{\text{DD}}$ rise/fall time		20			µs/V
					20	ms/V



### 5.3.3 Embedded reset and power control block characteristics

The parameters given in [Table 9](#) are derived from tests performed under ambient temperature and  $V_{DD}$  supply voltage conditions summarized in [Table 7](#).

**Table 9. Embedded reset and power control block characteristics**

Symbol	Parameter	Conditions	Min	Typ	Max	Unit
$V_{PVD}$	Programmable voltage detector level selection	PLS[2:0]=000 (rising edge)	2.1	2.18	2.26	V
		PLS[2:0]=000 (falling edge)	2	2.08	2.16	V
		PLS[2:0]=001 (rising edge)	2.19	2.28	2.37	V
		PLS[2:0]=001 (falling edge)	2.09	2.18	2.27	V
		PLS[2:0]=010 (rising edge)	2.28	2.38	2.48	V
		PLS[2:0]=010 (falling edge)	2.18	2.28	2.38	V
		PLS[2:0]=011 (rising edge)	2.38	2.48	2.58	V
		PLS[2:0]=011 (falling edge)	2.28	2.38	2.48	V
		PLS[2:0]=100 (rising edge)	2.47	2.58	2.69	V
		PLS[2:0]=100 (falling edge)	2.37	2.48	2.59	V
		PLS[2:0]=101 (rising edge)	2.57	2.68	2.79	V
		PLS[2:0]=101 (falling edge)	2.47	2.58	2.69	V
		PLS[2:0]=110 (rising edge)	2.66	2.78	2.9	V
		PLS[2:0]=110 (falling edge)	2.56	2.68	2.8	V
		PLS[2:0]=111 (rising edge)	2.76	2.88	3	V
PLS[2:0]=111 (falling edge)	2.66	2.78	2.9	V		
$V_{PVDhyst}$	PVD hysteresis			100		mV
$V_{POR/PDR}$	Power on/power down reset threshold	Falling edge	1.8	1.88	1.96	V
		Rising edge	1.84	1.92	2.0	V
$V_{PDRhyst}$	PDR hysteresis			40		mV
$t_{RSTTEMPO}$	Reset temporization		1.5	2.5	3.5	ms

### 5.3.4 Embedded reference voltage

The parameters given in [Table 10](#) are derived from tests performed under ambient temperature and  $V_{DD}$  supply voltage conditions summarized in [Table 7](#).

**Table 10. Embedded internal reference voltage**

Symbol	Parameter	Conditions	Min	Typ	Max	Unit
$V_{REFINT}$	Internal reference voltage	$-45\text{ }^{\circ}\text{C} < T_A < +85\text{ }^{\circ}\text{C}$	1.16	1.20	1.24	V



### 5.3.5 Supply current characteristics

The current consumption is measured as described in [Figure 9: Current consumption measurement scheme](#).

#### Maximum current consumption

The MCU is placed under the following conditions:

- All I/O pins are in input mode with a static value at  $V_{DD}$  or  $V_{SS}$  (no load)
- All peripherals are disabled except if it is explicitly mentioned
- The Flash access time is adjusted to  $f_{HCLK}$  frequency (0 wait state from 0 to 24 MHz, 1 wait state from 24 to 36 MHz)

The parameters given in [Table 11](#) are derived from tests performed under ambient temperature and  $V_{DD}$  supply voltage conditions summarized in [Table 7](#).

**Table 11. Maximum current consumption in Run and Sleep modes ( $T_A = 85\text{ °C}$ )<sup>(1)</sup>**

Symbol	Parameter	Conditions	$f_{HCLK}$	Typ <sup>(2)</sup>	Max <sup>(3)</sup>	Unit
$I_{DD}$	Supply current in Run mode	External clock with PLL, code running from Flash, all peripherals enabled (see RCC register description): $f_{PCLK1} = f_{HCLK}/2$ , $f_{PCLK2} = f_{HCLK}$	36 MHz	22	TBD	mA
			24 MHz	21	TBD	
		External clock, PLL stopped, code running from Flash, all peripherals enabled (see RCC register description): $f_{PCLK1} = f_{HCLK}/2$ , $f_{PCLK2} = f_{HCLK}$	8 MHz	10	TBD	
			External clock with PLL, code running from RAM, all peripherals enabled (see RCC register description): $f_{PCLK1} = f_{HCLK}/2$ , $f_{PCLK2} = f_{HCLK}$	36 MHz	13	
	24 MHz	11		15		
	Supply current in Sleep mode	External clock, PLL stopped, code running from RAM, all peripherals enabled (see RCC register description): $f_{PCLK1} = f_{HCLK}/2$ , $f_{PCLK2} = f_{HCLK}$	8 MHz	4.5	TBD	
			External clock with PLL, code running from RAM or Flash, all peripherals enabled (see RCC register description): $f_{PCLK1} = f_{HCLK}/2$ , $f_{PCLK2} = f_{HCLK}$	36 MHz	13	
24 MHz		10		17		
External clock, PLL stopped, code running from RAM or Flash, all peripherals enabled (see RCC register description): $f_{PCLK1} = f_{HCLK}/2$ , $f_{PCLK2} = f_{HCLK}$	8 MHz	3.5	TBD			

1. TBD stands for to be determined.

2. Typical values are measured at  $T_A = 25\text{ °C}$ , and  $V_{DD} = 3.3\text{ V}$ .

3. Data based on characterization results, tested in production at  $V_{Dmax}$ ,  $f_{HCLK\ max}$ ,  $T_{Amax}$ , and code executed from RAM.



Table 12. Maximum current consumption in Stop and Standby modes<sup>(1)</sup>

Symbol	Parameter	Conditions	Typ <sup>(2)</sup>		Max <sup>(3)</sup>	Unit
			V <sub>DD</sub> /V <sub>BAT</sub> = 2.4 V	V <sub>DD</sub> /V <sub>BAT</sub> = 3.3 V	T <sub>A</sub> = 85 °C	
I <sub>DD</sub>	Supply current in Stop mode	Regulator in Run mode, Low-speed and high-speed internal RC oscillators and high-speed oscillator OFF (no independent watchdog)	TBD	24	TBD	μA
		Regulator in Low Power mode, Low-speed and high-speed internal RC oscillators and high-speed oscillator OFF (no independent watchdog)	TBD <sup>(4)</sup>	14 <sup>(4)</sup>	TBD <sup>(4)</sup>	
	Supply current in Standby mode <sup>(5)</sup>	Low-speed internal RC oscillator and independent watchdog OFF, low-speed oscillator and RTC OFF	TBD <sup>(4)</sup>	2 <sup>(4)</sup>	TBD <sup>(4)</sup>	
I <sub>DD_VBA</sub> T	Backup domain supply current	Low-speed oscillator and RTC ON	1 <sup>(4)</sup>	1.4 <sup>(4)</sup>	TBD <sup>(4)</sup>	

1. TBD stands for to be determined.
2. Typical values are measured at T<sub>A</sub> = 25 °C, V<sub>DD</sub> = 3.3 V, unless otherwise specified.
3. Data based on characterization results, tested in production at V<sub>DD max</sub>, f<sub>HCLK max</sub>. and T<sub>A max</sub>.
4. Values expected for next silicon revision.
5. To have the Standby consumption with RTC ON, add I<sub>DD\_VBAT</sub> (Low-speed oscillator and RTC ON) to I<sub>DD</sub> Standby (when V<sub>DD</sub> is present the Backup Domain is powered by V<sub>DD</sub> supply).



**Typical current consumption**

The MCU is placed under the following conditions:

- All I/O pins are in input mode with a static value at  $V_{DD}$  or  $V_{SS}$  (no load)
- All peripherals are disabled except if it is explicitly mentioned
- The Flash access time is adjusted to  $f_{HCLK}$  frequency (0 wait state from 0 to 24 MHz, 1 wait state from 24 to 36 MHz)

The parameters given in [Table 13](#) are derived from tests performed under ambient temperature and  $V_{DD}$  supply voltage conditions summarized in [Table 7](#).

**Table 13. Typical current consumption in Run and Sleep modes<sup>(1)</sup>**

Symbol	Parameter	Conditions	$f_{HCLK}$	Typ <sup>(2)</sup>	Unit
$I_{DD}$	Supply current in Run mode	Oscillator running at 8 MHz with PLL, code running from Flash, all peripheral disabled (see RCC register description): $f_{PCLK1} = f_{HCLK}/2$ , $f_{PCLK2} = f_{HCLK}$	36 MHz	TBD	mA
			24 MHz	13	
			16 MHz	TBD	
		Running on HSI clock, code running from Flash, all peripheral disabled (see RCC register description): $f_{PCLK1} = f_{HCLK}/2$ , $f_{PCLK2} = f_{HCLK}$ . AHB pre-scaler used to reduce the frequency	8 MHz	7.8	mA
			4 MHz	7	
			2 MHz	6.3	
			1 MHz	6.2	
			500 kHz	6.1	
			125 kHz	5.95	
		Running on HSI clock, code running from RAM, all peripheral disabled (see RCC register description): $f_{PCLK1} = f_{HCLK}/2$ , $f_{PCLK2} = f_{HCLK}$ . AHB pre-scaler used to reduce the frequency	8 MHz	2.3	mA
			4 MHz	1.6	
			2 MHz	1.2	
			1 MHz	1	
			500 kHz	0.88	
			125 kHz	0.82	
Supply current in Sleep mode	Oscillator running at 8 MHz with PLL, code running from Flash, all peripheral disabled (see RCC register description): $f_{PCLK1} = f_{HCLK}/2$ , $f_{PCLK2} = f_{HCLK}$	36 MHz	TBD	mA	
		24 MHz	TBD		
		16 MHz	1		
	Running on HSI clock, code running from Flash, all peripheral disabled (see RCC register description): $f_{PCLK1} = f_{HCLK}/2$ , $f_{PCLK2} = f_{HCLK}$ . AHB pre-scaler used to reduce the frequency	8 MHz	TBD	mA	
		4 MHz	TBD		
		2 MHz	TBD		
		1 MHz	TBD		
		500 kHz	TBD		
		500 kHz	TBD		

1. TBD stands for to be determined.  
 2. Typical values are measures at  $T_A = 25\text{ }^\circ\text{C}$ ,  $V_{DD} = 3.3\text{ V}$ .



Table 14. Typical current consumption in Stop and Standby modes<sup>(1)</sup>

Symbol	Parameter	Conditions	V <sub>DD</sub>	Typ <sup>(2)</sup>	Unit
I <sub>DD</sub>	Supply current in Stop mode	Regulator in Run mode, Low-speed and high-speed internal RC oscillators OFF High-speed oscillator OFF (no independent watchdog)	3.3 V	24	μA
			2.4 V	TBD	
		Regulator in Low Power mode, Low-speed and high-speed internal RC oscillators OFF, High-speed oscillator OFF (no independent watchdog)	3.3 V	14 <sup>(3)</sup>	
			2.4 V	TBD <sup>(3)</sup>	
	Supply current in Standby mode <sup>(4)</sup>	Low-speed internal RC oscillator and independent watchdog OFF	3.3 V	2 <sup>(3)</sup>	μA
			2.4 V	TBD <sup>(3)</sup>	
		Low-speed internal RC oscillator and independent watchdog ON	3.3 V	3.1 <sup>(3)</sup>	
			2.4 V	TBD <sup>(3)</sup>	
		Low-speed internal RC oscillator ON, independent watchdog OFF	3.3 V	2.9 <sup>(3)</sup>	
			2.4 V	TBD <sup>(3)</sup>	
I <sub>DD_VBAT</sub>	Backup domain supply current	Low-speed oscillator and RTC ON	3.3 V	1.4 <sup>(3)</sup>	μA
			2.4 V	1 <sup>(3)</sup>	
		Low-speed oscillator OFF, RTC ON	3.3 V	0.5 <sup>(3)</sup>	
			2.4 V	TBD <sup>(3)</sup>	

1. TBD stands for to be determined.

2. Typical values are measures at T<sub>A</sub> = 25 °C, V<sub>DD</sub> = 3.3 V.

3. Values expected for next silicon revision.

4. To obtain Standby consumption with RTC ON, add I<sub>DD\_VBAT</sub> (Low-speed oscillator, RTC ON) to I<sub>DD</sub> Standby.



### 5.3.6 External clock source characteristics

#### High-speed user external clock

The characteristics given in [Table 15](#) result from tests performed using an high-speed external clock source, and under ambient temperature and supply voltage conditions summarized in [Table 7](#).

**Table 15. High-speed user external (HSE) clock characteristics**

Symbol	Parameter	Conditions	Min	Typ	Max	Unit
$f_{\text{HSE\_ext}}$	User external clock source frequency <sup>(1)</sup>			8	25	MHz
$V_{\text{HSEH}}$	OSC_IN input pin high level voltage		$0.7V_{\text{DD}}$		$V_{\text{DD}}$	V
$V_{\text{HSEL}}$	OSC_IN input pin low level voltage		$V_{\text{SS}}$		$0.3V_{\text{DD}}$	
$t_{\text{w(HSE)}}$ $t_{\text{w(HSE)}}$	OSC_IN high or low time <sup>(1)</sup>		16			ns
$t_{\text{r(HSE)}}$ $t_{\text{f(HSE)}}$	OSC_IN rise or fall time <sup>(1)</sup>				5	
$I_{\text{L}}$	OSC_IN Input leakage current	$V_{\text{SS}} \leq V_{\text{IN}} \leq V_{\text{DD}}$			$\pm 1$	$\mu\text{A}$

1. Value based on design simulation and/or technology characteristics. It is not tested in production.

#### Low-speed user external clock

The characteristics given in [Table 16](#) result from tests performed using an low-speed external clock source, and under ambient temperature and supply voltage conditions summarized in [Table 7](#).

**Table 16. Low-speed user external clock characteristics**

Symbol	Parameter	Conditions	Min	Typ	Max	Unit
$f_{\text{LSE\_ext}}$	User external clock source frequency <sup>(1)</sup>			32.768	1000	kHz
$V_{\text{LSEH}}$	OSC32_IN input pin high level voltage		$0.7V_{\text{DD}}$		$V_{\text{DD}}$	V
$V_{\text{LSEL}}$	OSC32_IN input pin low level voltage		$V_{\text{SS}}$		$0.3V_{\text{DD}}$	
$t_{\text{w(LSE)}}$ $t_{\text{w(LSE)}}$	OSC32_IN high or low time <sup>(1)</sup>		450			ns
$t_{\text{r(LSE)}}$ $t_{\text{f(LSE)}}$	OSC32_IN rise or fall time <sup>(1)</sup>				5	
$I_{\text{L}}$	OSC32_IN Input leakage current	$V_{\text{SS}} \leq V_{\text{IN}} \leq V_{\text{DD}}$			$\pm 1$	$\mu\text{A}$

1. Value based on design simulation and/or technology characteristics. It is not tested in production.





Figure 10. High-speed external clock source AC timing diagram

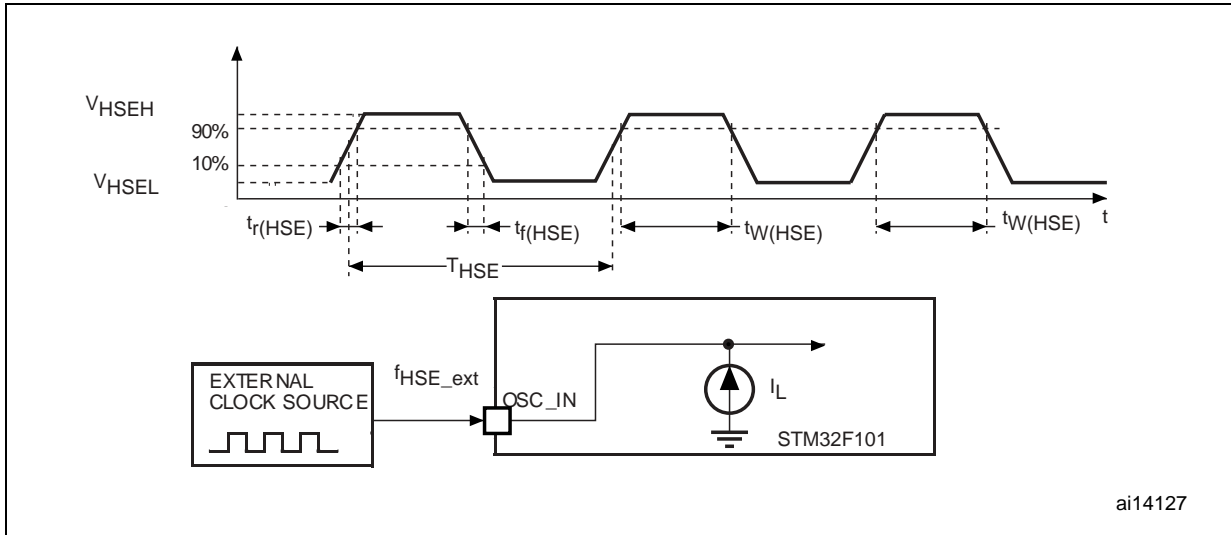
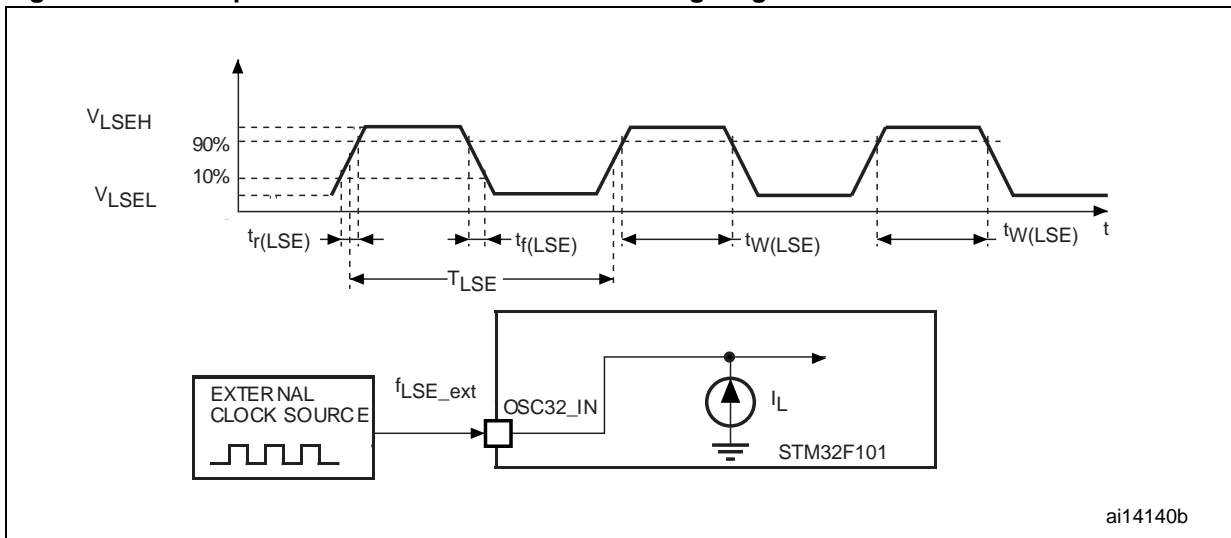

Figure 11. Low-speed external clock source AC timing diagram



### High-speed external clock

The high-speed external (HSE) clock can be supplied with a 4 to 16 MHz crystal/ceramic resonator oscillator. All the information given in this paragraph are based on characterization results obtained with typical external components specified in [Table 17](#). In the application, the resonator and the load capacitors have to be placed as close as possible to the oscillator pins in order to minimize output distortion and startup stabilization time. Refer to the crystal resonator manufacturer for more details on the resonator characteristics (frequency, package, accuracy).

**Table 17. HSE 4-16 MHz oscillator characteristics<sup>(1)</sup>**

Symbol	Parameter	Conditions	Min	Typ	Max	Unit
$f_{OSC\_IN}$	Oscillator frequency		4	8	16	MHz
$R_F$	Feedback resistor			200		k $\Omega$
$C_{L1}$ $C_{L2}^{(2)}$	Recommended load capacitance versus equivalent serial resistance of the crystal ( $R_S$ ) <sup>(3)</sup>	$R_S = 30 \Omega$		30		pF
$i_2$	HSE driving current	$V_{DD} = 3.3 V$ $V_{IN} = V_{SS}$ with 30 pF load			1	mA
$g_m$	Oscillator transconductance	Startup	25			mA/V
$t_{SU(HSE)}^{(4)}$	Startup time	$V_{SS}$ is stabilized		2		ms

1. Resonator characteristics given by the crystal/ceramic resonator manufacturer.
2. For  $C_{L1}$  and  $C_{L2}$  it is recommended to use high-quality ceramic capacitors in the 5 pF to 25 pF range (typ.), designed for high-frequency applications, and selected to match the requirements of the crystal or resonator.  $C_{L1}$  and  $C_{L2}$  are usually the same size. The crystal manufacturer typically specifies a load capacitance which is the series combination of  $C_{L1}$  and  $C_{L2}$ . PCB and MCU pin capacitance must be included when sizing  $C_{L1}$  and  $C_{L2}$  (10 pF can be used as a rough estimate of the combined pin and board capacitance).
3. The relatively low value of the  $R_F$  resistor offers a good protection against issues resulting from use in a humid environment, due to the induced leakage and the bias condition change. However, it is recommended to take this point into account if the MCU is used in tough humidity conditions.
4.  $t_{SU(HSE)}$  is the startup time measured from the moment it is enabled (by software) to a stabilized 8 MHz oscillation is reached. This value is measured for a standard crystal resonator and it can vary significantly with the crystal manufacturer

**Figure 12. Typical application with an 8 MHz crystal**

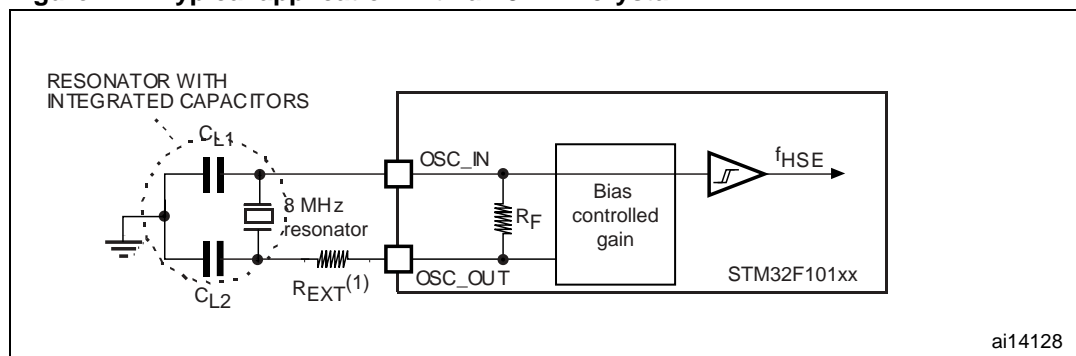

1.  $R_{EXT}$  value depends on the crystal characteristics. Typical value is in the range of 5 to 6 $R_S$ .

**Low-speed external clock**

The low-speed external (LSE) clock can be supplied with a 32.768 kHz crystal/ceramic resonator oscillator. All the information given in this paragraph are based on characterization results obtained with typical external components specified in [Table 18](#). In the application, the resonator and the load capacitors have to be placed as close as possible to the oscillator pins in order to minimize output distortion and startup stabilization time. Refer to the crystal resonator manufacturer for more details on the resonator characteristics (frequency, package, accuracy).

**Table 18. LSE oscillator characteristics ( $f_{LSE} = 32.768 \text{ kHz}$ )**

Symbol	Parameter	Conditions	Min	Typ	Max	Unit
$R_F$	Feedback resistor			5		$M\Omega$
$C_{L1}$ $C_{L2}$	Recommended load capacitance versus equivalent serial resistance of the crystal ( $R_S$ ) <sup>(1)</sup>	$R_S = 30 \text{ K}\Omega$			15	pF
$I_2$	LSE driving current	$V_{DD} = 3.3 \text{ V}$ $V_{IN} = V_{SS}$			1.4	$\mu\text{A}$
$g_m$	Oscillator transconductance		5			$\mu\text{A/V}$
$t_{SU(LSE)}$ <sup>(2)</sup>	Startup time	$V_{SS}$ is stabilized		3		s

1. The oscillator selection can be optimized in terms of supply current using an high quality resonator with small  $R_S$  value for example MSIV-TIN32.768 kHz. Refer to crystal manufacturer for more details
2.  $t_{SU(LSE)}$  is the startup time measured from the moment it is enabled (by software) to a stabilized 32.768 kHz oscillation is reached. This value is measured for a standard crystal resonator and it can vary significantly with the crystal manufacturer

**Figure 13. Typical application with a 32.768 kHz crystal**

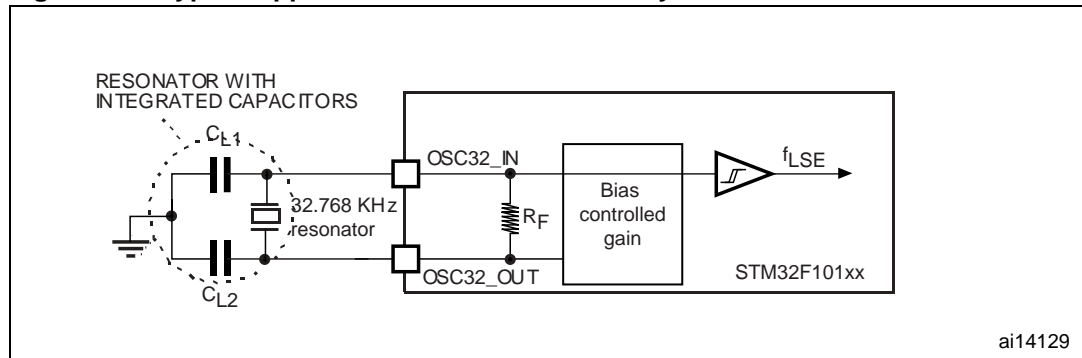

ai14129



### 5.3.7 Internal Clock source characteristics

The parameters given in [Table 19](#) are derived from tests performed under ambient temperature and  $V_{DD}$  supply voltage conditions summarized in [Table 7](#).

#### High-speed internal (HSI) RC oscillator

**Table 19. HSI oscillator characteristics<sup>(1)(2)</sup>**

Symbol	Parameter	Conditions	Min	Typ	Max <sup>(3)</sup>	Unit
$f_{HSI}$	Frequency			8		MHz
$ACC_{HSI}$	Accuracy of HSI oscillator	$T_A = -40$ to $85$ °C	TBD	$\pm 3$	TBD	%
		at $T_A = 25$ °C	TBD	$\pm 1$	TBD	%
$t_{su(HSI)}$	HSI oscillator startup time		1		2	$\mu s$
$I_{DD(HSI)}$	HSI oscillator power consumption			80	100	$\mu A$

- $V_{DD} = 3.3$  V,  $T_A = -40$  to  $85$  °C unless otherwise specified.
- TBD stands for to be determined.
- Values based on device characterization, not tested in production.

#### LSI Low Speed Internal RC Oscillator

**Table 20. LSI oscillator characteristics<sup>(1)</sup>**

Symbol	Parameter	Conditions	Min	Typ	Max <sup>(2)</sup>	Unit
$f_{LSI}$	Frequency		30		60	kHz
$t_{su(LSI)}$	LSI oscillator start up time				85	$\mu s$
$I_{DD(LSI)}$	LSI oscillator power consumption			0.65	1.2	$\mu A$

- $V_{DD} = 3$  V,  $T_A = -40$  to  $85$  °C unless otherwise specified.
- Value based on device characterization, not tested in production.



### Wakeup time from low power mode

The wakeup times given in [Table 21](#) is measured on a wakeup phase with a 8-MHz HSI RC oscillator. The clock source used to wake up the device depends from the current operating mode:

- Stop or Standby mode: the clock source is the RC oscillator
- Sleep mode: the clock source is the clock that was set before entering Sleep mode.

All timings are derived from tests performed under ambient temperature and  $V_{DD}$  supply voltage conditions summarized in [Table 7](#).

**Table 21. Low-power mode wakeup timings<sup>(1)</sup>**

Symbol	Parameter	Conditions	Typ	Max	Unit
$t_{WUSLEEP}^{(2)}$	Wakeup from Sleep mode	Wakeup on HSI RC clock	0.75	TBD	$\mu s$
$t_{WUSTOP}^{(2)}$	Wakeup from Stop mode (regulator in run mode)	HSI RC wakeup time = 2 $\mu s$	4	TBD	$\mu s$
	Wakeup from Stop mode (regulator in low power mode)	HSI RC wakeup time = 2 $\mu s$ , Regulator wakeup from LP mode time = 5 $\mu s$	7	TBD	
$t_{WUSTDBY}^{(3)}$	Wakeup from Standby mode	HSI RC wakeup time = 2 $\mu s$ , Regulator wakeup from power down time = 38 $\mu s$	40	TBD	$\mu s$

1. TBD stands for to be determined.
2. The wakeup time from Sleep and Stop mode are measured from the wakeup event to the point in which the user application code reads the first instruction.
3. The wakeup time from Standby mode is measured from the wakeup event to the point in which the device exits from reset.

### 5.3.8 PLL characteristics

The parameters given in [Table 22](#) are derived from tests performed under ambient temperature and  $V_{DD}$  supply voltage conditions summarized in [Table 7](#).

**Table 22. PLL characteristics<sup>(1)</sup>**

Symbol	Parameter	Test conditions	Value			Unit
			Min	Typ	Max <sup>(2)</sup>	
$f_{PLL\_IN}$	PLL input clock			8.0		MHz
	PLL input clock duty cycle		40		60	%
$f_{PLL\_OUT}$	PLL multiplier output clock		16		36	MHz
$t_{LOCK}$	PLL lock time				200	$\mu s$
$t_{JITTER}$	Cycle to cycle jitter (+/-3 $\Sigma$ peak to peak)	$V_{DD}$ is stable	TBD		TBD	%

1. TBD stands for to be determined.
2. Data based on device characterization, not tested in production.

### 5.3.9 Memory characteristics

#### Flash memory

The characteristics are given at  $T_A = -40$  to  $85$  °C unless otherwise specified.

**Table 23. Flash memory characteristics<sup>(1)</sup>**

Symbol	Parameter	Conditions	Min	Typ	Max <sup>(2)</sup>	Unit
$t_{prog}$	Word programming time	$T_A = -40$ to $+85$ °C	20		40	$\mu s$
$t_{ERASE}$	Page (1kB) erase time	$T_A = -40$ to $+85$ °C	20		40	ms
$t_{ME}$	Mass erase time	$T_A = -40$ to $+85$ °C	20		40	ms
$I_{DD}$	Supply current	Read mode $f_{HCLK} = 36$ MHz with 2 wait states, $V_{DD} = 3.3$ V			20	mA
		Write / Erase modes $f_{HCLK} = 36$ MHz, $V_{DD} = 3.3$ V			5	mA
		Power-down mode / HALT, $V_{DD} = 3.0$ to $3.6$ V			50	$\mu A$

1. TBD stands for to be determined.

2. Values based on characterization and not tested in production.

**Table 24. Flash endurance and data retention**

Symbol	Parameter	Conditions	Value			Unit
			Min <sup>(1)</sup>	Typ	Max	
$N_{END}$	Endurance		1	10		kcycles
$t_{RET}$	Data retention	$T_A = 85$ °C	30			Years

1. Values based on characterization not tested in production.



### 5.3.10 EMC characteristics

Susceptibility tests are performed on a sample basis during device characterization.

#### Functional EMS (Electromagnetic susceptibility)

While a simple application is executed on the device (toggling 2 LEDs through I/O ports), the device is stressed by two electromagnetic events until a failure occurs. The failure is indicated by the LEDs:

- **Electrostatic Discharge (ESD)** (positive and negative) is applied to all device pins until a functional disturbance occurs. This test is compliant with the IEC 1000-4-2 standard.
- **FTB:** A Burst of Fast Transient voltage (positive and negative) is applied to  $V_{DD}$  and  $V_{SS}$  through a 100 pF capacitor, until a functional disturbance occurs. This test is compliant with the IEC 1000-4-4 standard.

A device reset allows normal operations to be resumed.

The test results are given in [Table 25](#). They are based on the EMS levels and classes defined in application note AN1709.

**Table 25. EMS characteristics<sup>(1)</sup>**

Symbol	Parameter	Conditions	Level/Class
$V_{FESD}$	Voltage limits to be applied on any I/O pin to induce a functional disturbance	$V_{DD} = 3.3\text{ V}$ , $T_A = +25\text{ °C}$ , $f_{HCLK} = 36\text{ MHz}$ conforms to IEC 1000-4-2	TBD
$V_{EFTB}$	Fast transient voltage burst limits to be applied through 100pF on $V_{DD}$ and $V_{SS}$ pins to induce a functional disturbance	$V_{DD} = 3.3\text{ V}$ , $T_A = +25\text{ °C}$ , $f_{HCLK} = 36\text{ MHz}$ conforms to IEC 1000-4-4	4A

1. TBD stands for to be determined.

#### Designing hardened software to avoid noise problems

EMC characterization and optimization are performed at component level with a typical application environment and simplified MCU software. It should be noted that good EMC performance is highly dependent on the user application and the software in particular.

Therefore it is recommended that the user applies EMC software optimization and pre qualification tests in relation with the EMC level requested for his application.

#### Software recommendations

The software flowchart must include the management of runaway conditions such as:

- Corrupted program counter
- Unexpected reset
- Critical Data corruption (control registers...)



**Prequalification trials**

Most of the common failures (unexpected reset and program counter corruption) can be reproduced by manually forcing a low state on the NRST pin or the Oscillator pins for 1 second. To complete these trials, ESD stress can be applied directly on the device, over the range of specification values. When unexpected behavior is detected, the software can be hardened to prevent unrecoverable errors occurring (see application note AN1015).

**Electromagnetic Interference (EMI)**

The electromagnetic field emitted by the device is monitored while a simple application is executed (toggling 2 LEDs through the I/O ports). This emission test is compliant with SAE J 1752/3 standard which specifies the test board and the pin loading.

**Table 26. EMI characteristics<sup>(1)</sup>**

Symbol	Parameter	Conditions	Monitored frequency band	Max vs. [f <sub>HSE</sub> /f <sub>HCLK</sub> ]	Unit
				8/36 MHz	
S <sub>EMI</sub>	Peak level	V <sub>DD</sub> = 3.3 V, T <sub>A</sub> = 25 °C, LQFP100 package compliant with SAE J 1752/3	0.1 MHz to 30 MHz	TBD	dBµV
			30 MHz to 130 MHz	TBD	
			130 MHz to 1GHz	TBD	
			SAE EMI Level	TBD	-

1. TBD stands for to be determined.

**5.3.11 Absolute maximum ratings (electrical sensitivity)**

Based on three different tests (ESD, LU) using specific measurement methods, the device is stressed in order to determine its performance in terms of electrical sensitivity.

**Electrostatic discharge (ESD)**

Electrostatic discharges (a positive then a negative pulse separated by 1 second) are applied to the pins of each sample according to each pin combination. The sample size is either 3 parts (cumulative mode) or 3 parts × (n + 1) supply pins (non-cumulative mode). The human body model (HBM) can be simulated. The tests are compliant with JESD22-A114A standard.

For more details, refer to the application note AN1181.

**Table 27. ESD absolute maximum ratings<sup>(1)</sup>**

Symbol	Ratings	Conditions	Maximum value <sup>(2)</sup>	Unit
V <sub>ESD(HBM)</sub>	Electrostatic discharge voltage (human body model)	T <sub>A</sub> = +25 °C	2000	V
V <sub>ESD(CDM)</sub>	Electrostatic discharge voltage (charge device model)		TBD	

1. TBD stands for to be determined.

2. Values based on characterization results, not tested in production.





### Static latch-up

Two complementary static tests are required on 10 parts to assess the latch-up performance:

- A supply overvoltage is applied to each power supply pin
- A current injection is applied to each input, output and configurable I/O pin

These tests are compliant with EIA/JESD 78 IC latch-up standard.

**Table 28. Electrical sensitivities**

Symbol	Parameter	Conditions	Class
LU	Static latch-up class	$T_A = +105\text{ °C}$	II level A



### 5.3.12 I/O port characteristics

#### General input/output characteristics

Unless otherwise specified, the parameters given in [Table 29](#) are derived from tests performed under ambient temperature and  $V_{DD}$  supply voltage conditions summarized in [Table 7](#).

All unused pins must be held at a fixed voltage, by using the I/O output mode, an external pull-up or pull-down resistor (see [Figure 14](#)).

**Table 29. I/O static characteristics<sup>(1)</sup>**

Symbol	Parameter	Conditions	Min	Typ	Max	Unit
$V_{IL}$	Input low level voltage <sup>(2)</sup>	TTL ports	-0.5		0.8	V
$V_{IH}$	IO TC input high level voltage <sup>(2)</sup>		2		$V_{DD}+0.5$	
	IO FT high level voltage <sup>(2)</sup>		2		5.5V	
$V_{IL}$	Input low level voltage <sup>(2)</sup>	CMOS ports	-0.5		$0.35 V_{DD}$	V
$V_{IH}$	Input high level voltage <sup>(2)</sup>		$0.65 V_{DD}$		$V_{DD}+0.5$	
$V_{hys}$	IO TC Schmitt trigger voltage hysteresis <sup>(3)</sup>			200		mV
	IO TC Schmitt trigger voltage hysteresis <sup>(3)</sup>			$5\% V_{DD}$ <sup>(4)</sup>		mV
$I_{lkg}$	Input leakage current <sup>(4)</sup>	$V_{SS} \leq V_{IN} \leq V_{DD}$ Standard I/Os			$\pm 1$	$\mu A$
		$V_{IN} = 5 V$ 5 V tolerant I/Os			3	
$R_{PU}$	Weak pull-up equivalent resistor <sup>(5)</sup>	$V_{IN} = V_{SS}$	30	40	50	$k\Omega$
$R_{PD}$	Weak pull-down equivalent resistor <sup>(6)</sup>	$V_{IN} = V_{DD}$	30	40	50	$k\Omega$
$C_{IO}$	I/O pin capacitance			5		pF

- $V_{DD} = 3.3 V$ ,  $T_A = -40$  to  $85$  °C unless otherwise specified.
- Values based on characterization results, and not tested in production.
- Hysteresis voltage between Schmitt trigger switching levels. Based on characterization results, not tested.
- With a minimum of 100 mV.
- Leakage could be higher than max. if negative current is injected on adjacent pins.
- Pull-up and pull-down resistors are designed with a true resistance in series with a switchable PMOS/NMOS. This PMOS/NMOS contribution to the series resistance is minimum (~10% order).



Figure 14. Unused I/O pin connection

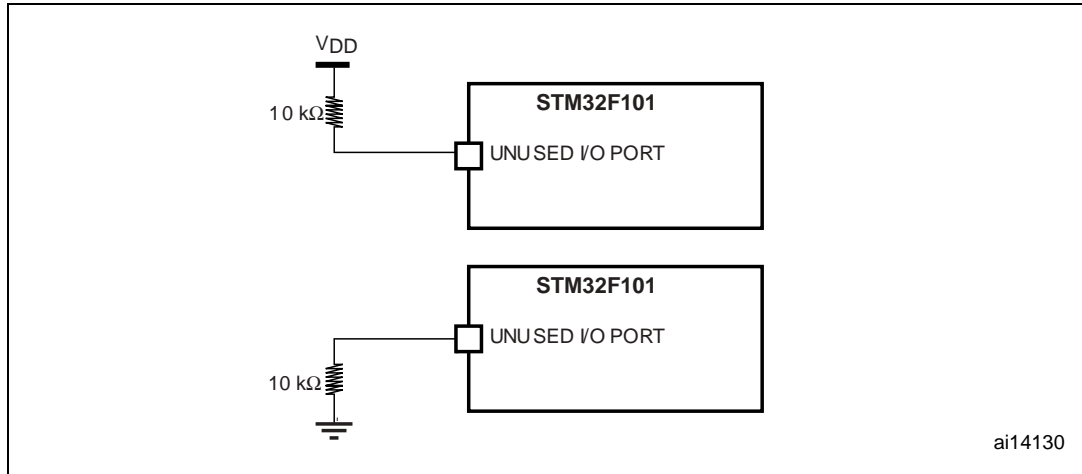

### Output driving current

The GPIOs (general purpose input/outputs) can sink or source up to +/-8 mA, and sink +20 mA (with a relaxed  $V_{OL}$ ).

In the user application, the number of I/O pins which can drive current must be limited to respect the absolute maximum rating specified in [Section 5.2](#):

- The sum of the currents sourced by all the I/Os on  $V_{DD}$ , plus the maximum Run consumption of the MCU sourced on  $V_{DD}$ , cannot exceed the absolute maximum rating  $I_{VDD}$  (see [Table 5](#)).
- The sum of the currents sunk by all the I/Os on  $V_{SS}$  plus the maximum Run consumption of the MCU sunk on  $V_{SS}$  cannot exceed the absolute maximum rating  $I_{VSS}$  (see [Table 5](#)).

## Output voltage levels

Unless otherwise specified, the parameters given in [Table 30](#) are derived from tests performed under ambient temperature and  $V_{DD}$  supply voltage conditions summarized in [Table 7](#).

**Table 30. Output voltage characteristics**

Symbol	Parameter	Conditions	Min	Max	Unit
$V_{OL}^{(1)}$	Output Low level voltage for an I/O pin when 8 pins are sunk at same time	TTL port, $I_{IO} = +8 \text{ mA}$ , $2.7 \text{ V} < V_{DD} < 3.6 \text{ V}$		0.4	V
$V_{OH}^{(2)}$	Output High level voltage for an I/O pin when 4 pins are sourced at same time		$V_{DD}-0.4$		
$V_{OL}^{(1)}$	Output low level voltage for an I/O pin when 8 pins are sunk at same time	CMOS port $I_{IO} = +8 \text{ mA}$ $2.7 \text{ V} < V_{DD} < 3.6 \text{ V}$		0.4	V
$V_{OH}^{(2)}$	Output high level voltage for an I/O pin when 4 pins are sourced at same time		2.4		
$V_{OL}^{(1)}$	Output low level voltage for an I/O pin when 8 pins are sunk at same time	$I_{IO} = +20 \text{ mA}$ $2.7 \text{ V} < V_{DD} < 3.6 \text{ V}$		1.3	V
$V_{OH}^{(2)}$	Output high level voltage for an I/O pin when 4 pins are sourced at same time		$V_{DD}-1.3$		
$V_{OL}^{(1)}$	Output low level voltage for an I/O pin when 8 pins are sunk at same time	$I_{IO} = +6 \text{ mA}$ $2 \text{ V} < V_{DD} < 2.7 \text{ V}$		0.4	V
$V_{OH}^{(2)}$	Output high level voltage for an I/O pin when 4 pins are sourced at same time		$V_{DD}-0.4$		

1. The  $I_{IO}$  current sunk by the device must always respect the absolute maximum rating specified in [Table 5](#) and the sum of  $I_{IO}$  (I/O ports and control pins) must not exceed  $I_{VSS}$ .
2. The  $I_{IO}$  current sourced by the device must always respect the absolute maximum rating specified in [Table 5](#) and the sum of  $I_{IO}$  (I/O ports and control pins) must not exceed  $I_{VDD}$ .



### Input/output AC characteristics

The definition and values of input/output AC characteristics are given in [Figure 15](#) and [Table 31](#), respectively.

Unless otherwise specified, the parameters given in [Table 31](#) are derived from tests performed under ambient temperature and  $V_{DD}$  supply voltage conditions summarized in [Table 7](#).

**Table 31. I/O AC characteristics<sup>(1)</sup>**

I/O mode <sup>(1)</sup>	Symbol	Parameter	Conditions	Max	Unit
10	$f_{\max(\text{IO})\text{out}}$	Maximum frequency <sup>(2)</sup>	$C_L = 50 \text{ pF}$ , $V_{DD} = 2 \text{ V to } 3.6 \text{ V}$	2	MHz
	$t_{f(\text{IO})\text{out}}$	Output high to low level fall time <sup>(3)</sup>	$C_L = 50 \text{ pF}$ , $V_{DD} = 2 \text{ V to } 3.6 \text{ V}$	125	ns
	$t_{r(\text{IO})\text{out}}$	Output low to high level rise time <sup>(3)</sup>		125	
01	$f_{\max(\text{IO})\text{out}}$	Maximum frequency <sup>(2)</sup>	$C_L = 50 \text{ pF}$ , $V_{DD} = 2 \text{ V to } 3.6 \text{ V}$	10	MHz
	$t_{f(\text{IO})\text{out}}$	Output high to low level fall time <sup>(3)</sup>	$C_L = 50 \text{ pF}$ , $V_{DD} = 2 \text{ V to } 3.6 \text{ V}$	25	ns
	$t_{r(\text{IO})\text{out}}$	Output low to high level rise time <sup>(3)</sup>		25	
11	$F_{\max(\text{IO})\text{out}}$	Maximum Frequency <sup>(2)</sup>	$C_L = 30 \text{ pF}$ , $V_{DD} = 2.7 \text{ V to } 3.6 \text{ V}$	50	MHz
			$C_L = 50 \text{ pF}$ , $V_{DD} = 2.7 \text{ V to } 3.6 \text{ V}$	30	MHz
			$C_L = 50 \text{ pF}$ , $V_{DD} = 2 \text{ V to } 2.7 \text{ V}$	20	MHz
	$t_{f(\text{IO})\text{out}}$	Output high to low level fall time <sup>(3)</sup>	$C_L = 30 \text{ pF}$ , $V_{DD} = 2.7 \text{ V to } 3.6 \text{ V}$	5	ns
			$C_L = 50 \text{ pF}$ , $V_{DD} = 2.7 \text{ V to } 3.6 \text{ V}$	8	
			$C_L = 50 \text{ pF}$ , $V_{DD} = 2 \text{ V to } 2.7 \text{ V}$	12	
	$t_{r(\text{IO})\text{out}}$	Output low to high level rise time <sup>(3)</sup>	$C_L = 30 \text{ pF}$ , $V_{DD} = 2.7 \text{ V to } 3.6 \text{ V}$	5	
			$C_L = 50 \text{ pF}$ , $V_{DD} = 2.7 \text{ V to } 3.6 \text{ V}$	8	
			$C_L = 50 \text{ pF}$ , $V_{DD} = 2 \text{ V to } 2.7 \text{ V}$	12	
-	$t_{\text{EXTI}pw}$	Pulse width of external signals detected by the EXTI controller		10	ns

1. Refer to the Reference user manual UM0306 for a description of GPIO Port configuration register.
2. The maximum frequency is defined in [Figure 15](#).
3. Values based on design simulation and validated on silicon, not tested in production.



Figure 15. I/O AC characteristics definition

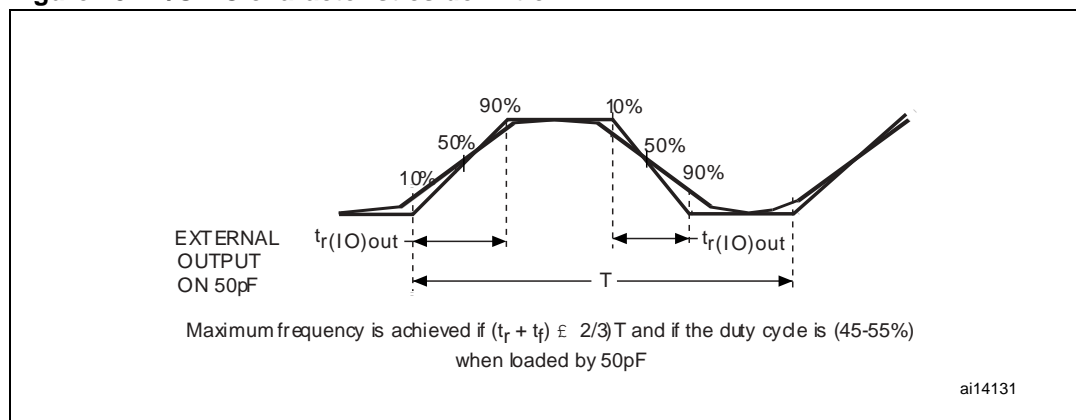

### 5.3.13 NRST pin characteristics

The NRST pin input driver uses CMOS technology. It is connected to a permanent pull-up resistor,  $R_{PU}$  (see [Table 29](#)).

Unless otherwise specified, the parameters given in [Table 32](#) are derived from tests performed under ambient temperature and  $V_{DD}$  supply voltage conditions summarized in [Table 7](#).

**Table 32. NRST pin characteristics<sup>(1)</sup>**

Symbol	Parameter	Conditions	Min	Typ	Max	Unit
$V_{IL(NRST)}$	NRST Input low level voltage		-0.5		0.8	V
$V_{IH(NRST)}$	NRST Input high level voltage		2		$V_{DD}+0.5$	
$V_{hys(NRST)}$	NRST Schmitt trigger voltage hysteresis			200		
$R_{PU}$	Weak pull-up equivalent resistor <sup>(2)</sup>	$V_{IN} = V_{SS}$	30	40	50	k $\Omega$
$V_{F(NRST)}$	NRST Input filtered pulse <sup>(3)</sup>				100	ns
$V_{NF(NRST)}$	NRST Input not filtered pulse <sup>(3)</sup>		300			$\mu$ s

1. TBD stands for to be determined.
2. The pull-up is designed with a true resistance in series with a switchable PMOS. This PMOS contribution to the series resistance must be minimum (~10% order).
3. Values guaranteed by design, not tested in production.

**Figure 16. Recommended NRST pin protection**

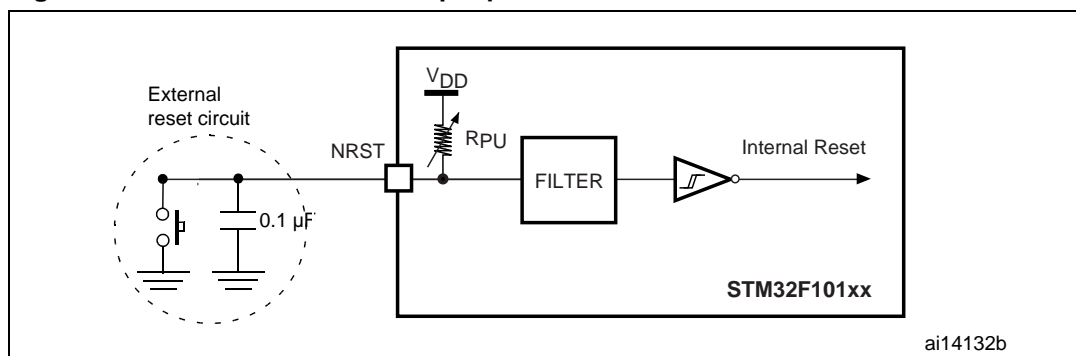

1. The reset network protects the device against parasitic resets.
2. The user must ensure that the level on the NRST pin can go below the  $V_{IL(NRST)}$  max level specified in [Table 32](#). Otherwise the reset will not be taken into account by the device.

### 5.3.14 TIM timer characteristics

Unless otherwise specified, the parameters given in [Table 33](#) are derived from tests performed under ambient temperature,  $f_{PCLKx}$  frequency and  $V_{DD}$  supply voltage conditions summarized in [Table 7](#).

Refer to [Section 5.3.12: I/O port characteristics](#) for details on the input/output alternate function characteristics (output compare, input capture, external clock, PWM output).

**Table 33. TIMx characteristics**

Symbol	Parameter	TIMx <sup>(1)</sup>	Conditions	Min	Max	Unit
$t_{res(TIM)}$	Timer resolution time	x = 2, 3, 4		1		$t_{TIMxCLK}$
			$f_{TIMxCLK} = 36$ MHz	27.8		ns
$f_{EXT}$	Timer external clock frequency on CH1 to CH4	x = 2, 3, 4		0	$f_{TIMxCLK}/2$	MHz
			$f_{TIMxCLK} = 36$ MHz	0	18	MHz
$Res_{TIM}$	Timer resolution				16	bit
$t_{COUNTER}$	16-bit counter clock period when internal clock is selected	x = 2, 3, 4		1	65536	$t_{TIMxCLK}$
			$f_{TIMxCLK} = 36$ MHz	0.0278	1820	$\mu$ s
$t_{MAX\_COUNT}$	Maximum possible count	x = 2, 3, 4			$65536 \times 65536$	$t_{TIMxCLK}$
			$f_{TIMxCLK} = 36$ MHz		119.2	s

1. x gives the TIM concerned; where x = 2, TIM2 is concerned, etc.





### 5.3.15 Communications interfaces

#### I<sup>2</sup>C interface characteristics

Unless otherwise specified, the parameters given in [Table 34](#) are derived from tests performed under ambient temperature,  $f_{\text{PCLK1}}$  frequency and  $V_{\text{DD}}$  supply voltage conditions summarized in [Table 7](#).

The STM32F101xx access line I<sup>2</sup>C interface meets the requirements of the standard I<sup>2</sup>C communication protocol with the following restrictions: the I/O pins SDA and SCL are mapped to are not “true” open-drain. When configured as open-drain, the PMOS connected between the I/O pin and  $V_{\text{DD}}$  is disabled, but is still present. In addition, there is a protection diode between the I/O pin and  $V_{\text{DD}}$ . As a consequence, when multiple master devices are connected to the I<sup>2</sup>C bus, it is not possible to power off the STM32F101xx while another I<sup>2</sup>C master node remains powered on. Otherwise, the ST device would be powered by the protection diode.

The I<sup>2</sup>C characteristics are described in [Table 34](#). Refer also to [Section 5.3.12: I/O port characteristics](#) for more details on the input/output alternate function characteristics (SDA and SCL).

**Table 34. I<sup>2</sup>C characteristics**

Symbol	Parameter	Standard mode I <sup>2</sup> C <sup>(1)</sup>		Fast mode I <sup>2</sup> C <sup>(1)(2)</sup>		Unit
		Min	Max	Min	Max	
$t_{\text{w(SCLL)}}$	SCL clock low time	4.7		1.3		$\mu\text{s}$
$t_{\text{w(SCLH)}}$	SCL clock high time	4.0		0.6		
$t_{\text{su(SDA)}}$	SDA setup time	250		100		ns
$t_{\text{h(SDA)}}$	SDA data hold time	0 <sup>(3)</sup>		0 <sup>(4)</sup>	900 <sup>(3)</sup>	
$t_{\text{r(SDA)}}$ $t_{\text{r(SCL)}}$	SDA and SCL rise time		1000	$20+0.1C_{\text{b}}$	300	
$t_{\text{f(SDA)}}$ $t_{\text{f(SCL)}}$	SDA and SCL fall time		300	$20+0.1C_{\text{b}}$	300	
$t_{\text{h(STA)}}$	Start condition hold time	4.0		0.6		$\mu\text{s}$
$t_{\text{su(STA)}}$	Repeated Start condition setup time	4.7		0.6		
$t_{\text{su(STO)}}$	Stop condition setup time	4.0		0.6		$\mu\text{s}$
$t_{\text{w(STO:STA)}}$	Stop to Start condition time (bus free)	4.7		1.3		$\mu\text{s}$
$C_{\text{b}}$	Capacitive load for each bus line		400		400	pF

1. Values based on standard I<sup>2</sup>C protocol requirement, not tested in production.
2.  $f_{\text{PCLK1}}$  must be higher than 2 MHz to achieve the maximum standard mode I<sup>2</sup>C frequency. It must be higher than 4 MHz to achieve the maximum fast mode I<sup>2</sup>C frequency.
3. The maximum hold time of the Start condition has only to be met if the interface does not stretch the low period of SCL signal.
4. The device must internally provide a hold time of at least 300 ns for the SDA signal in order to bridge the undefined region of the falling edge of SCL.



Figure 17. I<sup>2</sup>C bus AC waveforms and measurement circuit

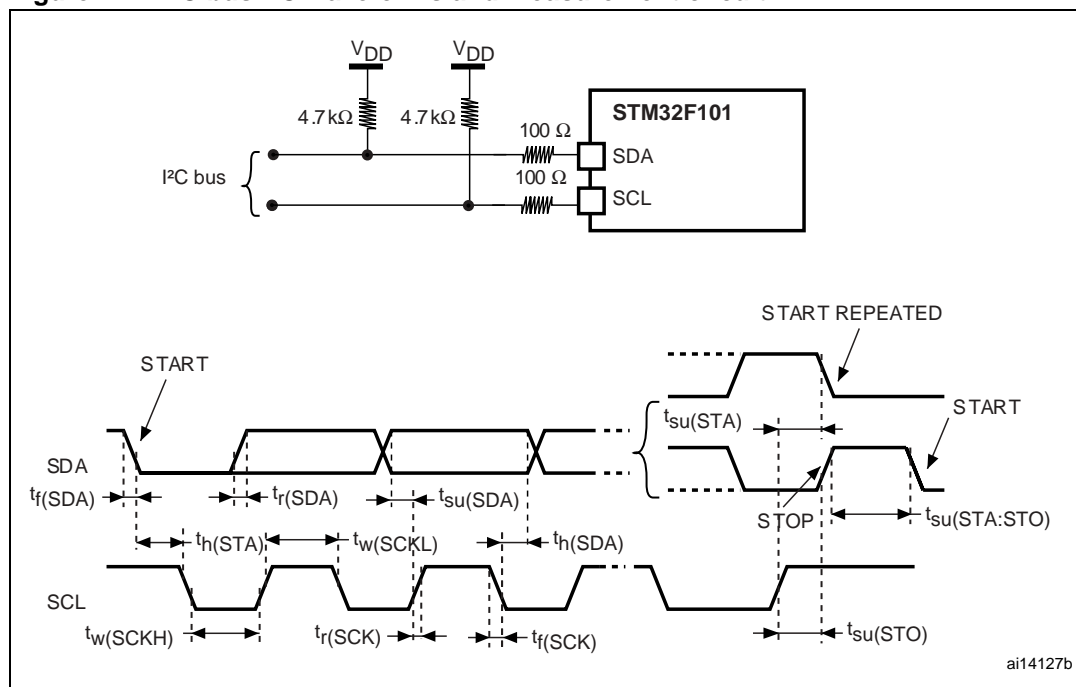

1. Measurement points are done at CMOS levels: 0.3V<sub>DD</sub> and 0.7V<sub>DD</sub>.

Table 35. SCL frequency (f<sub>PCLK1</sub>= 36 MHz, V<sub>DD</sub> = 3.3 V)<sup>(1)(2)(3)</sup>

f <sub>SCL</sub> (kHz)	I2C_CCR value
	R <sub>P</sub> = 4.7 kΩ
400	TBD
300	TBD
200	TBD
100	TBD
50	TBD
20	TBD

1. TBD = to be determined.
2. R<sub>P</sub> = External pull-up resistance, f<sub>SCL</sub> = I<sup>2</sup>C speed,
3. For speeds around 200 kHz, the tolerance on the achieved speed is of ±5%. For other speed ranges, the tolerance on the achieved speed ±2%. These variations depend on the accuracy of the external components used to design the application.



### SPI interface characteristics

Unless otherwise specified, the parameters given in [Table 36](#) are derived from tests performed under ambient temperature,  $f_{PCLKx}$  frequency and  $V_{DD}$  supply voltage conditions summarized in [Table 7](#).

Refer to [Section 5.3.12: I/O port characteristics](#) for more details on the input/output alternate function characteristics (NSS, SCK, MOSI, MISO).

**Table 36. SPI characteristics<sup>(1)</sup>**

Symbol	Parameter	Conditions	Min	Max	Unit
$f_{SCK}$ $1/t_c(SCK)$	SPI clock frequency	Master mode	TBD	TBD	MHz
		Slave mode	0	TBD	
$t_r(SCK)$ $t_f(SCK)$	SPI clock rise and fall time	Capacitive load: C = 50 pF		TBD	ns
$t_{su(NSS)}^{(2)}$	NSS setup time	Slave mode	0		
$t_{h(NSS)}^{(2)}$	NSS hold time	Slave mode	0		
$t_w(SCKH)^{(2)}$ $t_w(SCKL)^{(2)}$	SCK high and low time	Master mode, $f_{PCLK} = TBD$ , presc = TBD	TBD		
$t_{su(MI)}^{(2)}$ $t_{su(SI)}^{(2)}$	Data input setup time	Master mode	TBD		
		Slave mode	TBD		
$t_{h(MI)}^{(2)}$ $t_{h(SI)}^{(2)}$	Data input hold time	Master mode	TBD		
		Slave mode	TBD		
		Master mode, $f_{PCLK} = TBD$	TBD <sup>(3)</sup>		
		Slave mode, $f_{PCLK} = TBD$	TBD <sup>(3)</sup>		
$t_{a(SO)}^{(2)(4)}$	Data output access time	Slave mode	TBD	TBD	
		Slave mode, $f_{PCLK} = TBD$	TBD	TBD	
$t_{dis(SO)}^{(2)(5)}$	Data output disable time	Slave mode	TBD	TBD	
$t_{v(SO)}^{(2)(1)}$	Data output valid time	Slave mode (after enable edge)		TBD	
		$f_{PCLK} = TBD$		TBD	
$t_{v(MO)}^{(2)(1)}$	Data output valid time	Master mode (after enable edge)		TBD	
		$f_{PCLK} = TBD$	TBD	TBD	
$t_{h(SO)}^{(2)}$ $t_{h(MO)}^{(2)}$	Data output hold time	Slave mode (after enable edge)	TBD		
		Master mode (after enable edge)	TBD		

1. TBD = to be determined.
2. Values based on design simulation and/or characterization results, and not tested in production.
3. Depends on  $f_{PCLK}$ . For example, if  $f_{PCLK} = 8$  MHz, then  $t_{PCLK} = 1/f_{PCLK} = 125$  ns and  $t_{v(MO)} = 255$  ns.
4. Min time is for the minimum time to drive the output and the max time is for the maximum time to validate the data.
5. Min time is for the minimum time to invalidate the output and the max time is for the maximum time to put the data in Hi-Z.

Figure 18. SPI timing diagram - slave mode and CPHA=0

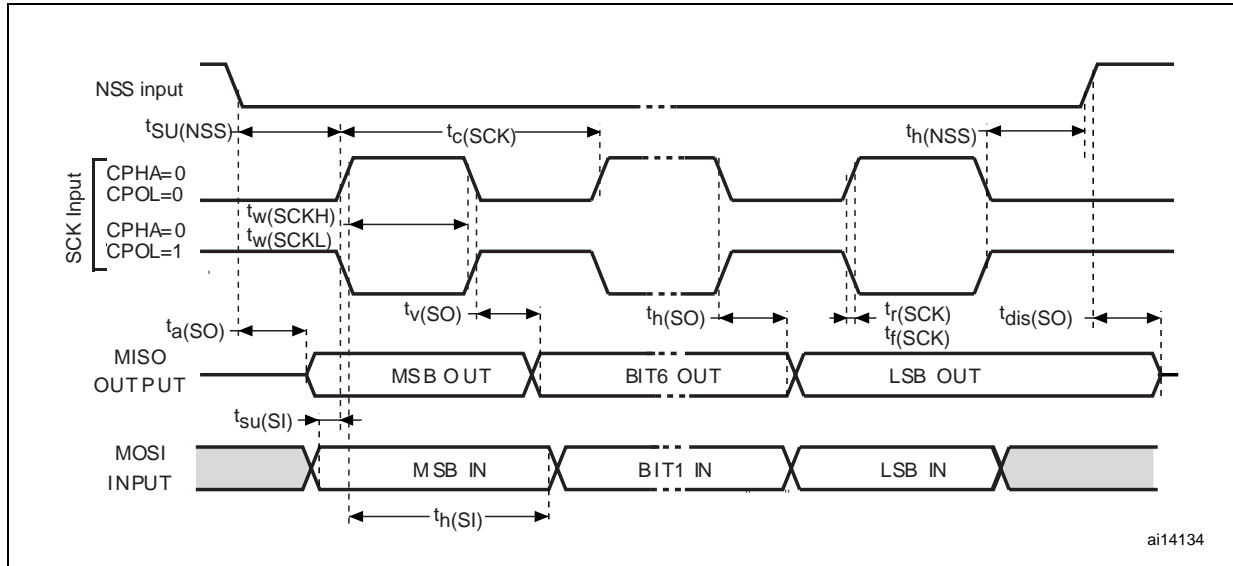

1. Measurement points are done at CMOS levels:  $0.3V_{DD}$  and  $0.7V_{DD}$ .

Figure 19. SPI timing diagram - slave mode and CPHA=1<sup>1)</sup>

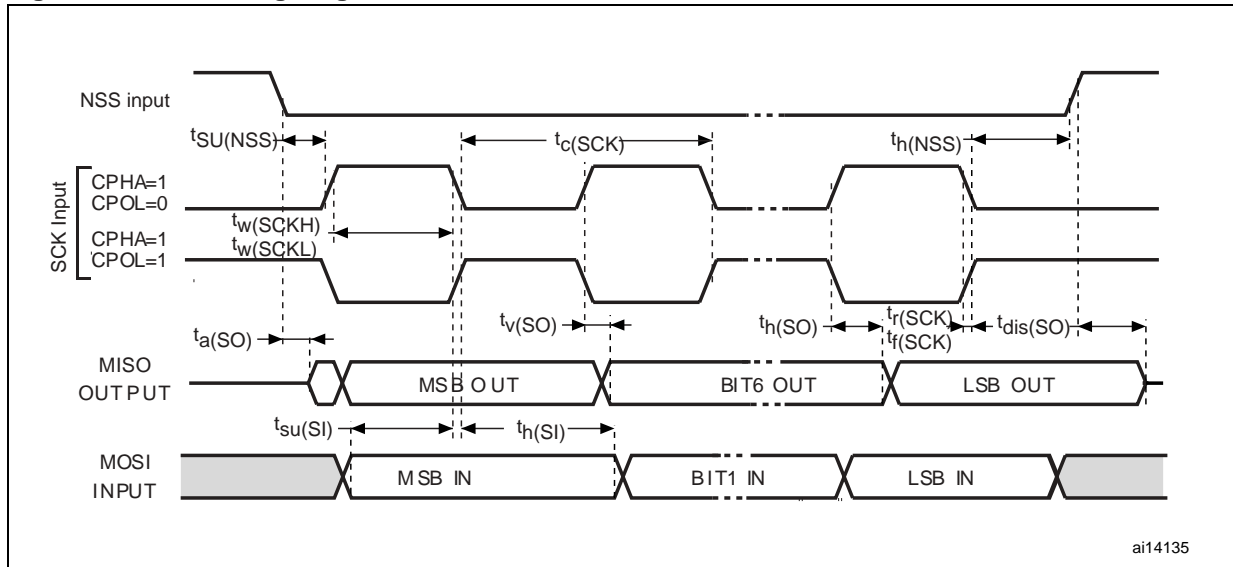
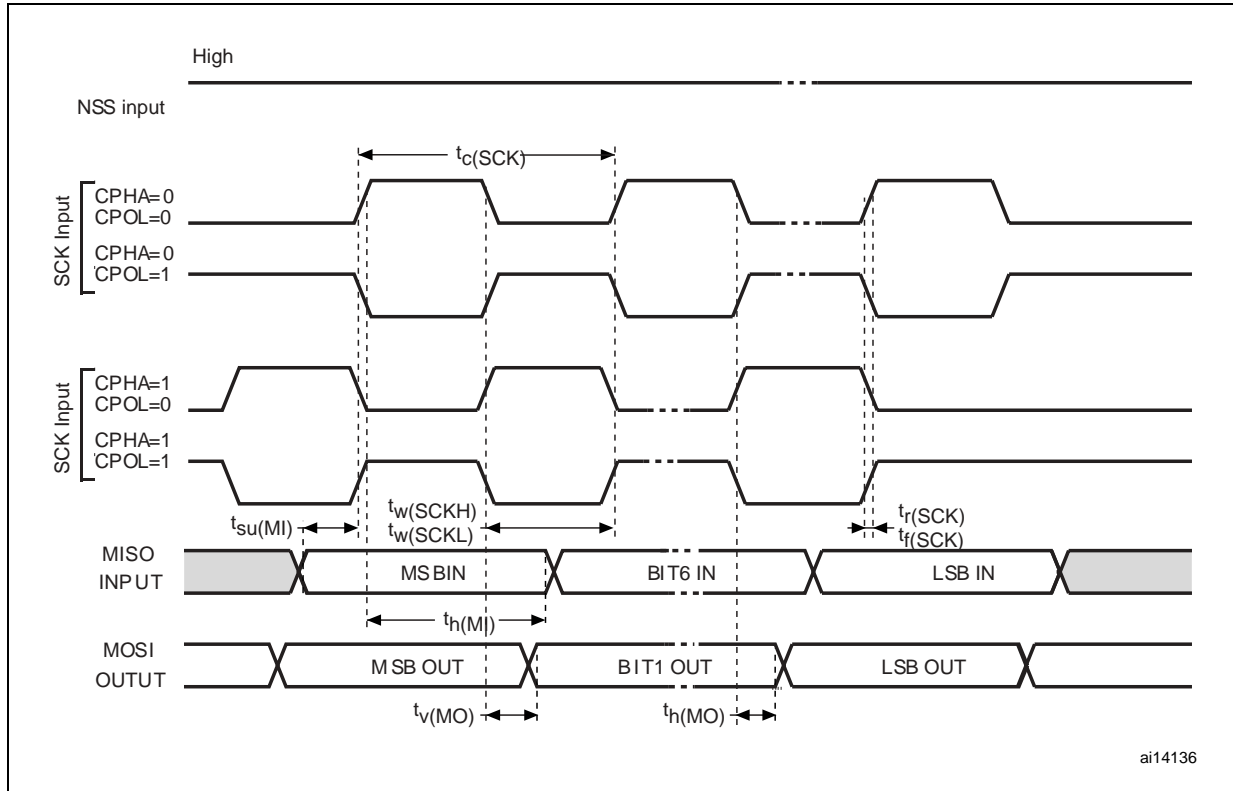

Figure 20. SPI timing diagram - master mode



1. Measurement points are done at CMOS levels:  $0.3V_{DD}$  and  $0.7V_{DD}$ .



### 5.3.16 12-bit ADC characteristics

Unless otherwise specified, the parameters given in [Table 37](#) are derived from tests performed under ambient temperature,  $f_{PCLK2}$  frequency and  $V_{DDA}$  supply voltage conditions summarized in [Table 7](#).

*Note:* It is recommended to perform a calibration after each power-up.

**Table 37. ADC characteristics<sup>(1)</sup>**

Symbol	Parameter	Conditions	Min	Typ	Max	Unit
$V_{DDA}$	ADC power supply		2.4		3.6	V
$V_{REF+}$	Positive reference voltage		2.0		$V_{DDA}$	V
$f_{ADC}$	ADC clock frequency		0.6		14	MHz
$f_S$	Sampling rate	TBD	0.05		1	MHz
$f_{TRIG}$	External trigger frequency	$f_{ADC} = 14$ MHz			823	kHz
					17	
$V_{AIN}$	Conversion voltage range <sup>2)</sup>		$V_{SSA}$		$V_{DDA}$	V
$R_{AIN}$	External input impedance		TBD <sup>(2)(3)</sup>			k $\Omega$
$C_{AIN}$	External capacitor on analog input					pF
$I_{lkg}$	Negative input leakage current on analog pins	$V_{IN} < V_{SS},  I_{IN}  < 400 \mu A$ on adjacent analog pin		5	6	$\mu A$
$R_{ADC}$	Sampling switch resistance				1	k $\Omega$
$C_{ADC}$	Internal sample and hold capacitor				5	pF
$t_{CAL}$	Calibration time	$f_{ADC} = 14$ MHz	5.9			$\mu s$
			83			
$t_{lat}$	Injection conversion latency	$f_{ADC} = 14$ MHz			0.214	$\mu s$
					3	$1/f_{ADC}$
$t_S$	Sampling time	$f_{ADC} = 14$ MHz	0.107		17.1	$\mu s$
$t_{STAB}$	Power-up time		0	0	1	$\mu s$
$t_{CONV}$	Total conversion time (including sampling time)	$f_{ADC} = 14$ MHz	1		18	$\mu s$
			14 (1.5 for sampling +12.5 for successive approximation)			

1. TBD = to be determined.
2. Depending on the input signal variation ( $f_{AIN}$ ),  $C_{AIN}$  can be increased for stabilization time and reduced to allow the use of a larger serial resistor ( $R_{AIN}$ ). It is valid for all  $f_{ADC}$  frequencies  $\leq 14$  MHz.
3. During the sample time the input capacitance  $C_{AIN}$  (5 max) can be charged/discharged by the external source. The internal resistance of the analog source must allow the capacitance to reach its final voltage level within  $t_S$ . After the end of the sample time  $t_S$ , changes of the analog input voltage have no effect on the conversion result. Values for the sample clock  $t_S$  depend on programming.

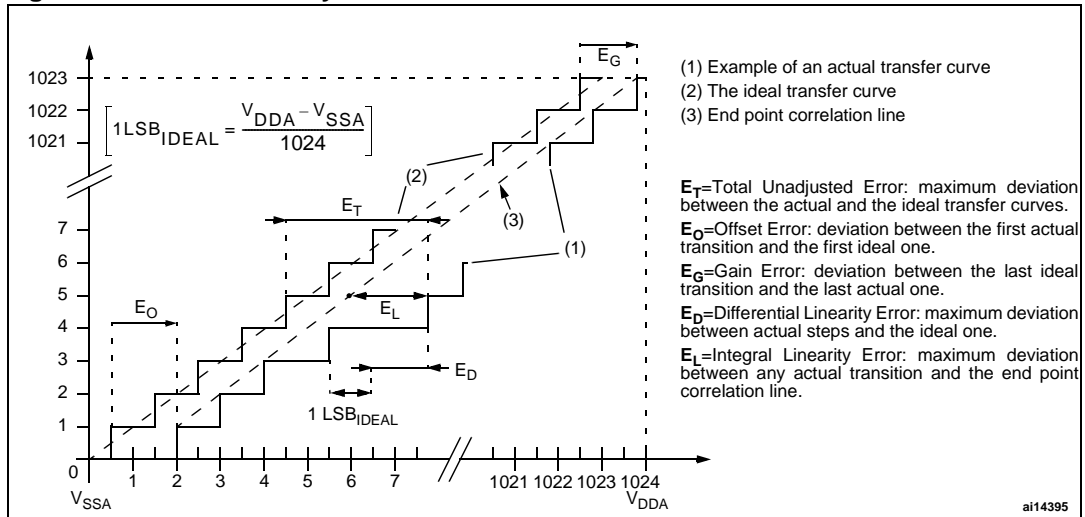

**Table 38. ADC accuracy ( $f_{PCLK2} = 10 \text{ MHz}$ ,  $f_{ADC} = 10 \text{ MHz}$ ,  $R_{AIN} < 10 \text{ k}\Omega$ ,  $V_{DDA} = 3.3 \text{ V}$ )<sup>(1)</sup>**

Symbol	Parameter	Conditions	Typ	Max	Unit
$ E_T $	Total unadjusted error <sup>(2)</sup>		3	TBD	LSB
$ E_O $	Offset error <sup>(2)</sup>		1	TBD	
$ E_G $	Gain Error <sup>(2)</sup>		2	TBD	
$ E_D $	Differential linearity error <sup>(2)</sup>		3	TBD	
$ E_L $	Integral linearity error <sup>(2)</sup>		2	TBD	

- TBD = to be determined.
- ADC Accuracy vs. Negative Injection Current: Injecting negative current on any of the standard (non-robust) analog input pins should be avoided as this significantly reduces the accuracy of the conversion being performed on another analog input. It is recommended to add a Schottky diode (pin to ground) to standard analog pins which may potentially inject negative current. Any positive injection current within the limits specified for  $I_{INJ(PIN)}$  and  $\Sigma I_{INJ(PIN)}$  in [Section 5.3.12](#) does not affect the ADC accuracy.

**Figure 21. ADC accuracy characteristics**



**Figure 22. Typical connection diagram using the ADC**

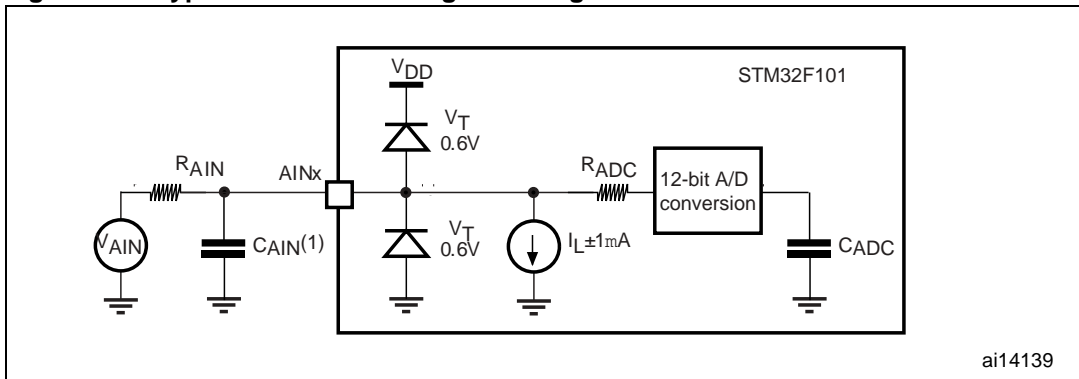

- Refer to [Table 37](#) for the values of  $R_{ADC}$  and  $C_{ADC}$ .
- $C_{PARASITIC}$  must be added to  $C_{AIN}$ . It represents the capacitance of the PCB (dependent on soldering and PCB layout quality) plus the pad capacitance (3 pF). A high  $C_{PARASITIC}$  value will downgrade conversion accuracy. To remedy this,  $f_{ADC}$  should be reduced.

**General PCB design guidelines**

Power supply decoupling should be performed as shown in [Figure 23](#) or [Figure 24](#), depending on whether  $V_{REF+}$  is connected to  $V_{DDA}$  or not. The 10 nF capacitors should be ceramic (good quality). They should be placed them as close as possible to the chip.

**Figure 23. Power supply and reference decoupling ( $V_{REF+}$  not connected to  $V_{DDA}$ )**

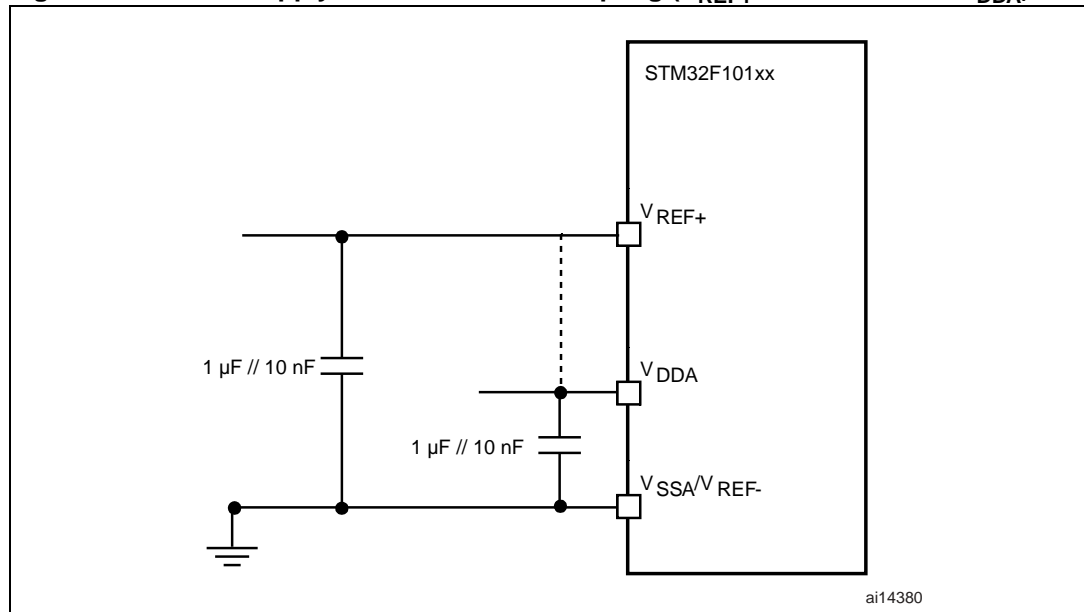

- 1.  $V_{REF+}$  and  $V_{REF-}$  inputs are available only on 100-pin packages.

**Figure 24. Power supply and reference decoupling ( $V_{REF+}$  connected to  $V_{DDA}$ )**

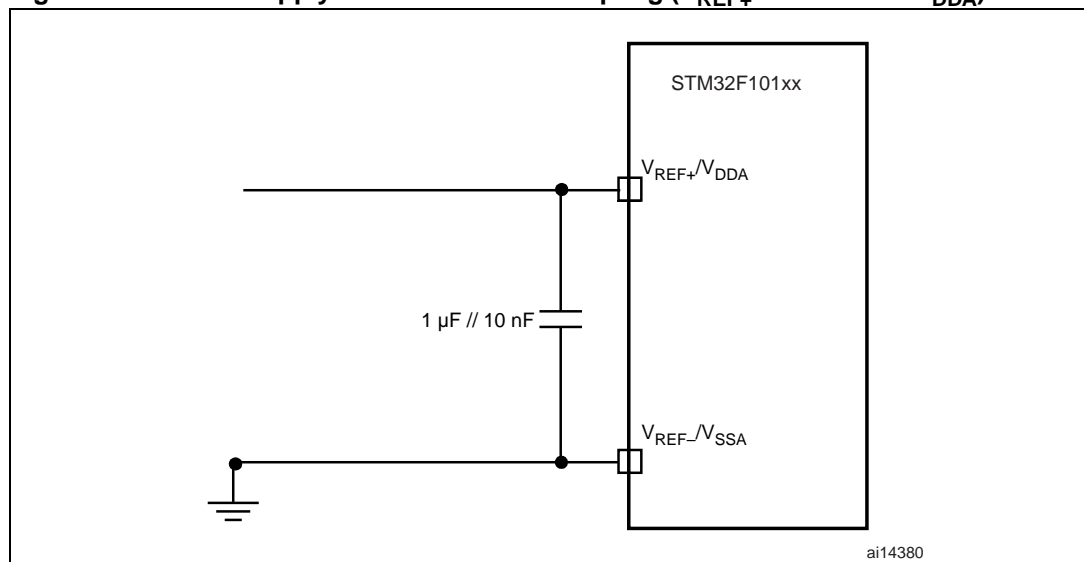

- 1.  $V_{REF+}$  and  $V_{REF-}$  inputs are available only on 100-pin packages.





### 5.3.17 Temperature sensor characteristics

**Table 39. TS characteristics**

Symbol	Parameter	Conditions	Min	Typ	Max	Unit
$T_L$	$V_{SENSE}$ linearity with temperature			$\pm 1.5$		$^{\circ}\text{C}$
Avg_Slope	Average slope			4.478		mV/ $^{\circ}\text{C}$
$V_{25}$	Voltage at 25 $^{\circ}\text{C}$			1.4		V
$t_{START}$	Startup time		4		10	$\mu\text{s}$



## 6 Package characteristics

Figure 25. LQPF100 – 100-pin low-profile quad flat package outline

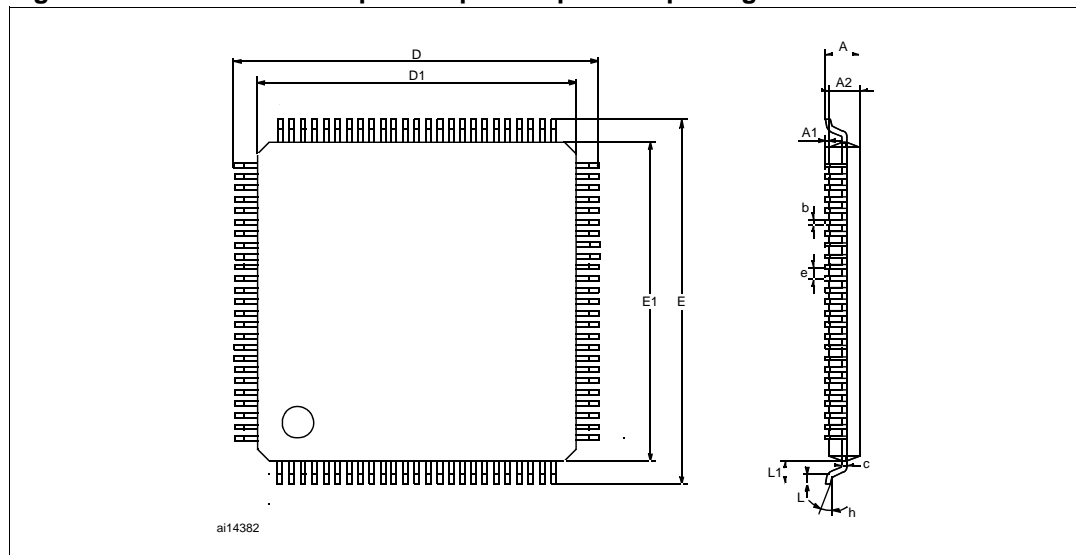

Table 40. LQPF100 – 100-pin low-profile quad flat package mechanical data

Dim.	mm			inches		
	Min	Typ	Max	Min	Typ	Max
A			1.60			0.063
A1	0.05		0.15	0.002		0.006
A2	1.35	1.40	1.45	0.053	0.055	0.057
b	0.17	0.22	0.27	0.007	0.009	0.011
C	0.09		0.20	0.004		0.008
D		16.00			0.630	
D1		14.00			0.551	
E		16.00			0.630	
E1		14.00			0.551	
e		0.50			0.020	
θ	0°	3.5°	7°	0°	3.5°	7°
L	0.45	0.60	0.75	0.018	0.024	0.030
L1		1.00			0.039	
	<b>Number of pins</b>					
N	100					



Figure 26. LQFP64 – 64-pin low-profile quad flat package outline

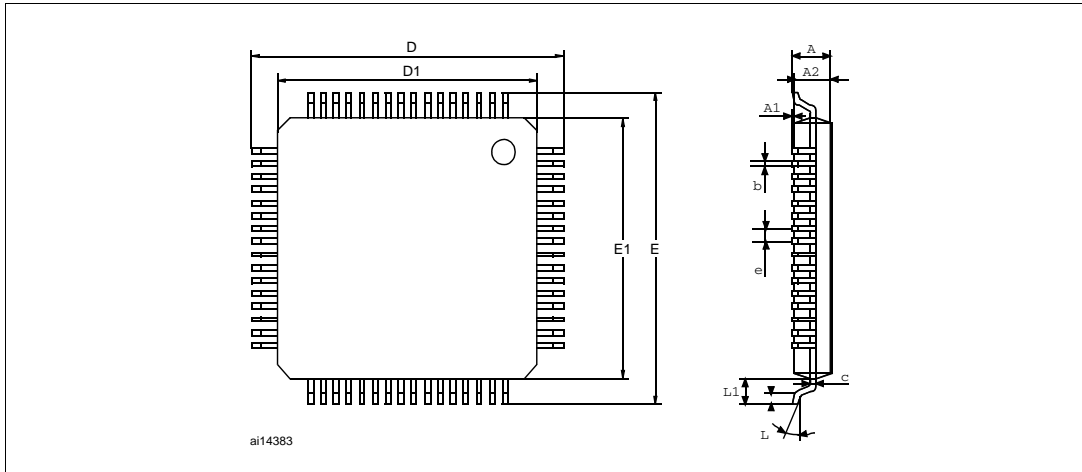

Table 41. LQFP64 – 64-pin low-profile quad flat package mechanical data

Dim.	mm			inches		
	Min	Typ	Max	Min	Typ	Max
A			1.60			0.063
A1	0.05		0.15	0.002		0.006
A2	1.35	1.40	1.45	0.053	0.055	0.057
b	0.17	0.22	0.27	0.007	0.009	0.011
c	0.09		0.20	0.004		0.008
D		12.00			0.472	
D1		10.00			0.394	
E		12.00			0.472	
E1		10.00			0.394	
e		0.50			0.020	
θ	0°	3.5°	7°	0°	3.5°	7°
L	0.45	0.60	0.75	0.018	0.024	0.030
L1		1.00			0.039	
	<b>Number of pins</b>					
N	64					



Figure 27. LQFP48 – 48-pin low-profile quad flat package outline

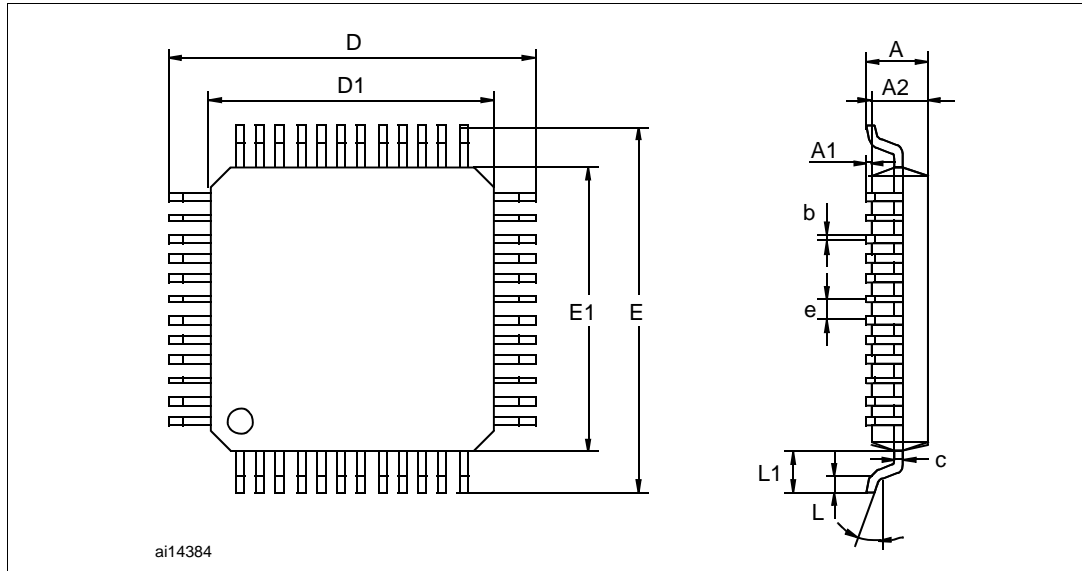

Table 42. LQFP48 – 48-pin low-profile quad flat package mechanical data

Dim.	mm			inches <sup>(1)</sup>		
	Min	Typ	Max	Min	Typ	Max
A			1.60			0.063
A1	0.05		0.15	0.002		0.006
A2	1.35	1.40	1.45	0.053	0.055	0.057
b	0.17	0.22	0.27	0.007	0.009	0.011
C	0.09		0.20	0.004		0.008
D		9.00			0.354	
D1		7.00			0.276	
E		9.00			0.354	
E1		7.00			0.276	
e		0.50			0.020	
θ	0°	3.5°	7°	0°	3.5°	7°
L	0.45	0.60	0.75	0.018	0.024	0.030
L1		1.00			0.039	
	<b>Number of pins</b>					
N	48					

1. Values in inches are converted from mm and rounded to 3 decimal digits.



## 6.1 Thermal characteristics

The average chip-junction temperature,  $T_J$ , in degrees Celsius, may be calculated using the following equation:

$$T_J = T_A + (P_D \times \Theta_{JA}) \quad (1)$$

Where:

- $T_A$  is the ambient temperature in °C,
- $\Theta_{JA}$  is the package junction-to-ambient thermal resistance, in °C/W,
- $P_D$  is the sum of  $P_{INT}$  and  $P_{I/O}$  ( $P_D = P_{INT} + P_{I/O}$ ),
- $P_{INT}$  is the product of  $I_{DD}$  and  $V_{DD}$ , expressed in Watts. This is the chip internal power.

$P_{I/O}$  represents the power dissipation on input and output pins;

Most of the time for the application  $P_{I/O} < P_{INT}$  and can be neglected. On the other hand,  $P_{I/O}$  may be significant if the device is configured to drive continuously external modules and/or memories.

An approximate relationship between  $P_D$  and  $T_J$  (if  $P_{I/O}$  is neglected) is given by:

$$P_D = K / (T_J + 273 \text{ °C}) \quad (2)$$

Therefore (solving equations 1 and 2):

$$K = P_D \times (T_A + 273 \text{ °C}) + \Theta_{JA} \times P_D^2 \quad (3)$$

where:

K is a constant for the particular part, which may be determined from equation (3) by measuring  $P_D$  (at equilibrium) for a known  $T_A$ . Using this value of K, the values of  $P_D$  and  $T_J$  may be obtained by solving equations (1) and (2) iteratively for any value of  $T_A$ .

**Table 43. Thermal characteristics**

Symbol	Parameter	Value	Unit
$\Theta_{JA}$	Thermal resistance junction-ambient LQFP 100 - 14 x 14 mm / 0.5 mm pitch	46	°C/W
	Thermal resistance junction-ambient LQFP 64 - 10 x 10 mm / 0.5 mm pitch	45	
	Thermal resistance junction-ambient LQFP 48 - 7 x 7 mm / 0.5 mm pitch	55	



## 7 Order codes

Table 44. Order codes

Partnumber	Flash program memory Kbytes	SRAM memory Kbytes	Package
STM32F101C6T6	32	6	LQFP48
STM32F101C8T6	64	10	
STM32F101R6T6	32	6	LQFP64
STM32F101R8T6	64	10	
STM32F101RBT6	128	16	
STM32F101V8T6	64	10	LQFP100
STM32F101VBT6	128	16	

### 7.1 Future family enhancements

Further developments of the STM32F101xx access line will see an expansion of the current options. Larger packages will soon be available with up to 512KB Flash, 48KB SRAM and with extended features such as EMI support, DAC and additional timers and USARTS.



## 8 Revision history

**Table 45. Document revision history**

Date	Revision	Changes
06-Jun-2007	1	First draft.
20-Jul-07	2	<p><math>I_{DD}</math> values modified in <a href="#">Table 11: Maximum current consumption in Run and Sleep modes (<math>T_A = 85\text{ }^\circ\text{C}</math>)</a>.</p> <p><math>V_{BAT}</math> range modified in <a href="#">Power supply schemes</a>.</p> <p><math>V_{REF+}</math> min value, <math>t_{STAB}</math>, <math>t_{lat}</math> and <math>f_{TRIG}</math> added to <a href="#">Table 37: ADC characteristics</a>. <a href="#">Table 33: TIMx characteristics</a> modified.</p> <p><a href="#">Note 5</a> modified and <a href="#">Note 7</a>, <a href="#">Note 4</a> and <a href="#">Note 6</a> added below <a href="#">Table 3: Pin definitions</a>.</p> <p><a href="#">Figure 11: Low-speed external clock source AC timing diagram</a>, <a href="#">Figure 8: Power supply scheme</a>, <a href="#">Figure 16: Recommended NRST pin protection</a> and <a href="#">Figure 17: I<sup>2</sup>C bus AC waveforms and measurement circuit</a> modified.</p> <p>Sample size modified and machine model removed in <a href="#">Electrostatic discharge (ESD)</a>.</p> <p>Number of parts modified and standard reference updated in <a href="#">Static latch-up</a>. <math>25\text{ }^\circ\text{C}</math> and <math>85\text{ }^\circ\text{C}</math> conditions removed and class name modified in <a href="#">Table 28: Electrical sensitivities</a>.</p> <p><math>t_{SU(LSE)}</math> changed to <math>t_{SU(LSE)}</math> in <a href="#">Table 17: HSE 4-16 MHz oscillator characteristics</a>.</p> <p>In <a href="#">Table 24: Flash endurance and data retention</a>, typical endurance added, data retention for <math>T_A = 25\text{ }^\circ\text{C}</math> removed and data retention for <math>T_A = 85\text{ }^\circ\text{C}</math> added. Note removed below <a href="#">Table 7: General operating conditions</a>.</p> <p><math>V_{BG}</math> changed to <math>V_{REFINT}</math> in <a href="#">Table 10: Embedded internal reference voltage</a>. <math>I_{DD}</math> max values added to <a href="#">Table 11: Maximum current consumption in Run and Sleep modes (<math>T_A = 85\text{ }^\circ\text{C}</math>)</a>.</p> <p><math>I_{DD(HSI)}</math> max value added to <a href="#">Table 19: HSI oscillator characteristics</a>.</p> <p><math>R_{PU}</math> and <math>R_{PD}</math> min and max values added to <a href="#">Table 29: I/O static characteristics</a>. <math>R_{PU}</math> min and max values added to <a href="#">Table 32: NRST pin characteristics</a> (two notes removed).</p> <p>Datasheet title corrected. USB characteristics section removed.</p> <p><a href="#">Features on page 1</a> list optimized. Small text changes.</p>

**Please Read Carefully:**

Information in this document is provided solely in connection with ST products. STMicroelectronics NV and its subsidiaries ("ST") reserve the right to make changes, corrections, modifications or improvements, to this document, and the products and services described herein at any time, without notice.

All ST products are sold pursuant to ST's terms and conditions of sale.

Purchasers are solely responsible for the choice, selection and use of the ST products and services described herein, and ST assumes no liability whatsoever relating to the choice, selection or use of the ST products and services described herein.

No license, express or implied, by estoppel or otherwise, to any intellectual property rights is granted under this document. If any part of this document refers to any third party products or services it shall not be deemed a license grant by ST for the use of such third party products or services, or any intellectual property contained therein or considered as a warranty covering the use in any manner whatsoever of such third party products or services or any intellectual property contained therein.

**UNLESS OTHERWISE SET FORTH IN ST'S TERMS AND CONDITIONS OF SALE ST DISCLAIMS ANY EXPRESS OR IMPLIED WARRANTY WITH RESPECT TO THE USE AND/OR SALE OF ST PRODUCTS INCLUDING WITHOUT LIMITATION IMPLIED WARRANTIES OF MERCHANTABILITY, FITNESS FOR A PARTICULAR PURPOSE (AND THEIR EQUIVALENTS UNDER THE LAWS OF ANY JURISDICTION), OR INFRINGEMENT OF ANY PATENT, COPYRIGHT OR OTHER INTELLECTUAL PROPERTY RIGHT.**

**UNLESS EXPRESSLY APPROVED IN WRITING BY AN AUTHORIZED ST REPRESENTATIVE, ST PRODUCTS ARE NOT RECOMMENDED, AUTHORIZED OR WARRANTED FOR USE IN MILITARY, AIR CRAFT, SPACE, LIFE SAVING, OR LIFE SUSTAINING APPLICATIONS, NOR IN PRODUCTS OR SYSTEMS WHERE FAILURE OR MALFUNCTION MAY RESULT IN PERSONAL INJURY, DEATH, OR SEVERE PROPERTY OR ENVIRONMENTAL DAMAGE. ST PRODUCTS WHICH ARE NOT SPECIFIED AS "AUTOMOTIVE GRADE" MAY ONLY BE USED IN AUTOMOTIVE APPLICATIONS AT USER'S OWN RISK.**

Resale of ST products with provisions different from the statements and/or technical features set forth in this document shall immediately void any warranty granted by ST for the ST product or service described herein and shall not create or extend in any manner whatsoever, any liability of ST.

ST and the ST logo are trademarks or registered trademarks of ST in various countries.

Information in this document supersedes and replaces all information previously supplied.

The ST logo is a registered trademark of STMicroelectronics. All other names are the property of their respective owners.

© 2007 STMicroelectronics - All rights reserved

STMicroelectronics group of companies

Australia - Belgium - Brazil - Canada - China - Czech Republic - Finland - France - Germany - Hong Kong - India - Israel - Italy - Japan - Malaysia - Malta - Morocco - Singapore - Spain - Sweden - Switzerland - United Kingdom - United States of America

[www.st.com](http://www.st.com)

