

[查询VAD2150供应商](#)

[捷多邦, 专业PCB打样工厂, 24小时加急出货](#)

VAD 2150
Video A/D Converter



Contents

Page	Section	Title
3	1.	Introduction
3	1.1.	General Description
3	1.2.	Features
4	1.3.	Environment
4	2.	Specifications
4	2.1.	Outline Dimensions
4	2.2.	Pin Connections
5	2.3.	Pin Descriptions
6	2.4.	Pin Circuits
7	2.5.	Electrical Characteristics
7	2.5.1.	Absolute Maximum Ratings
7	2.5.2.	Recommended Operating Conditions
9	2.5.3.	Characteristics
10	2.5.4.	Performance Characteristics
10	2.5.5.	Waveforms
11	3.	Functional Description



1.3. Environment

In Fig. 1-1, there is shown the block diagram of the video section of a digital TV receiver according to the DIGIT 2000 concept, which is equipped with the picture-in-picture facility. Besides the already known ICs for the main picture, there is the section for the small secondary picture in the lower half of this figure. This section is composed of the VAD 2150 Video A/D Converter, the VSP 2850 Video/Sync Processor, optionally the SPU 2220 SECAM Processor, the PIP 2250 Picture-In-Picture Processor and two DRAMs, 16 K x 4 each.

2. Specifications

2.1. Outline Dimensions

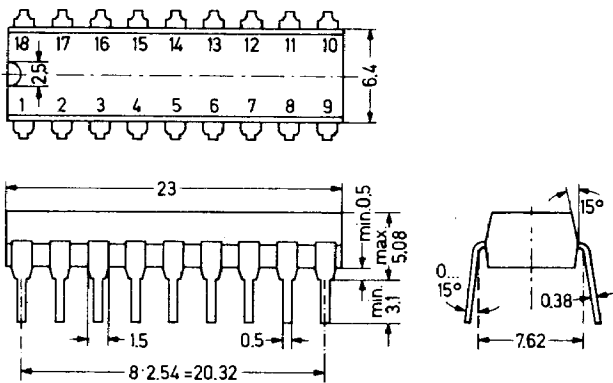

Fig. 2-1:

VAD 2150 in 18-pin D11 Plastic Package, 28 A 18 according to DIN 41 870

Weight approx. 1.4 g
Dimensions in mm

2.2. Pin Connections

1	Ground of Digital Supply	10	SV Video Select Input
2	V_{SUP1} Digital Supply Voltage	11	UH Undelayed Horizontal Blanking Pulse Input
3	V0 Video Output (LSB)	12	AIA Analog Input A
4	V1 Video Output	13	V_{SUP1} Analog Supply Voltage, Reference Voltage Low-End Capacitor Pin
5	V2 Video Output	14	V_{SUP2} Analog Supply Voltage
6	V3 Video Output	15	Reference Voltage High-End Capacitor Pin
7	V4 Video Output	16	AIB Analog Input B
8	V5 Video Output	17	Ground of Analog Supply
9	V6 Video Output (MSB)	18	\emptyset M Main Clock Input



2.3. Pin Descriptions

Pins 1 and 2 - Digital Power Supply

Via these pins, the digital part of the VAD 2150 is supplied. Usually, pin 1 is the ground of the digital circuitry at the video outputs of the VAD and of the digital control circuitry, e.g. clock generator etc.

Pins 3 to 9 - Digital Video Outputs (Fig. 2-5)

The push-pull outputs at these pins supply the digital output word of the A/D converter in the Gray code.

Pin 10 - SV Video Select Input (Fig. 2-3)

Low level at this digital input activates the AIA analog input A (pin 12). High level selects the AIB analog input B (pin 16)

Pin 11 - UH Undelayed Horizontal Blanking Pulse Input (Fig. 2-3)

When using the gain doubling facility during the horizontal blanking interval, the horizontal blanking pulse must be supplied to pin 11. The UH signal must be Low during the blanking time and High during the active line. Because of the pseudo eight-bit operation, the LH transition of UH will toggle the reference voltage of the A/D converter. If unused, pin 11 must be connected to V_{SUP1} (pin 2).

Pins 12 and 16 - AIA and AIB Analog Inputs A and B (Fig. 2-2)

The analog input voltages to be converted into digital are fed to the VAD 2150 via these pins. A simple external clamping circuit is described in the data sheet of the DPU 2543 Deflection Processor. If one of the two analog inputs is permanently not used, it should be connected to analog ground.

Pins 13, 14 and 17 - Analog Power Supply

The analog sections of the VAD 2150 are supplied via these pins. Care should be taken to keep away noise and distortions generated by digital circuits. The lower end of the internal reference resistor chain is internally connected to the analog supply voltage pin 13. Due to this reason, pins 13 and 17 must be linked via a decoupling capacitor of sufficient capacity. The analog ground pin 17 is the reference point for the analog input voltages.

Pin 15 - Reference Voltage High-End Capacitor Pin

This pin is connected to the internally-stabilized reference voltage of the A/D converters which is derived from the V_{SUP2} supply of pin 14. Pin 15 must be connected via a decoupling capacitor to the lower end of the internal reference resistor chain, which is pin 13.

Pin 18 - \emptyset M Main Clock Input (Pin 2-4)

To this pin must be connected the system clock which may originate from an MCU 2600 or MCU 2632 Clock Generator, the VSP 2850 Video/Sync Processor or from a TTL or CMOS compatible output.



2.4. Pin Circuits

The following figures schematically show the circuitry at the various pins.

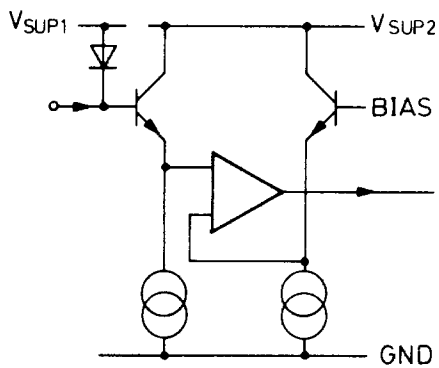

Fig. 2-2:
Input Pins 12 and 16

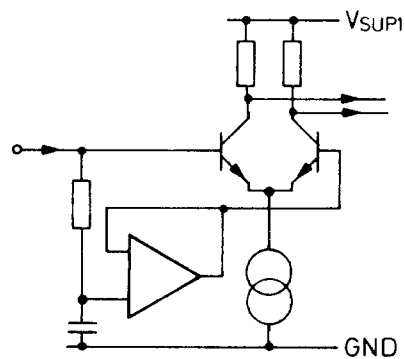

Fig. 2-4:
Input Pin 18

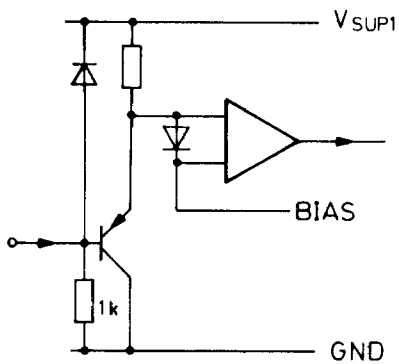

Fig. 2-3:
Input Pins 10 and 11

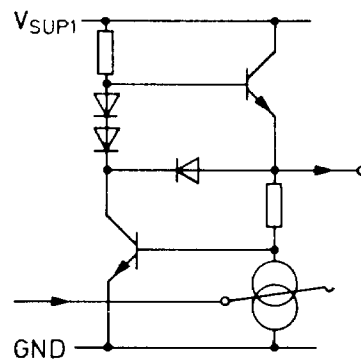

Fig. 2-5:
Output Pins 3 to 9



2.5. Electrical Characteristics

All voltages are referred to ground.

2.5.1. Absolute Maximum Ratings

Symbol	Parameter	Pin No.	Min.	Max.	Unit
T_A	Ambient Operating Temperature	-	0	65	$^{\circ}\text{C}$
T_S	Storage Temperature	-	-40	+125	$^{\circ}\text{C}$
V_{SUP1}	Supply Voltage	2, 13	-	6	V
V_{SUP2}	Supply Voltage	14	-	15	V
$V_{\text{ØMI}}$	ØM Main Clock Input Voltage	18	0	V_{SUP1}	-
V_{SVI}	SV Video Select Input Voltage	10	0	V_{SUP1}	-
V_{UHI}	UH Undelayed Horizontal Blanking Pulse Input Voltage	11	0	V_{SUP1}	-
V_{AI}	Analog Input Voltage	12, 16	4	8	V
I_{VO}	Video Output Current	3 to 9	-4	+4	mA

2.5.2. Recommended Operating Conditions

at $T_A = 0$ to 65°C , $f_{\text{ØM}} = 5$ to 20 MHz

Symbol	Parameter	Pin No.	Min.	Typ.	Max.	Unit
V_{SUP1}	Supply Voltage	2, 13	4.75	5.0	5.25	V
V_{SUP2}	Supply Voltage	14	11	12	14	V
$V_{\text{ØMIDC}}$	ØM Main Clock Input D.C. Voltage	18	1.5	-	3.5	V
$V_{\text{ØMIAC}}$	ØM Main Clock Input A.C. Voltage (p-p)		0.8	-	2.5	V
$\frac{t_{\text{ØMIH}}}{t_{\text{ØMIL}}}$	ØM Main Clock Input High/Low Ratio		0.9	1.0	1.1	-

Recommended Operating Conditions, continued

Symbol	Parameter	Pin No.	Min.	Typ.	Max.	Unit
$t_{\emptyset MIHL}$	$\emptyset M$ Main Clock Input High to Low Transition Time	18	-	-	$\frac{0.15}{f_{\emptyset M}}$	-
V_{AIAPP}	Analog Input A Peak-to-Peak Voltage	12	-	2	-	V
V_{AIAR}	Analog Input A Voltage Range		5.0	-	7.0	V
V_{AIBPP}	Analog Input B Peak-to-Peak Voltage	16	-	1	-	V
V_{AIBR}	Analog Input B Voltage Range		5.0	-	6.0	V
V_{SVIL}	SV Video Select Input Low Voltage	10	-	-	0.8	V
V_{SVIH}	SV Video Select Input High Voltage		2.0	-	-	V
V_{UHIL}	UH Undelayed Horizontal Blanking Pulse Input Low Voltage	11	-	-	0.8	V
V_{UHIH}	UH Undelayed Horizontal Blanking Pulse Input High Voltage		2.0	-	-	V
C_{RLH}	Reference Voltage High-End Decoupling Capacitor	15, 13	-	0.1 ceramic and - 10 electrolytic	-	μF μF
C_{RVL}	Reference Voltage Low-End Decoupling Capacitor	13, 17	-	0.1 ceramic and - 10 electrolytic	-	μF μF
C_{SV}	Supply Voltage Decoupling Capacitor	14, 17	-	0.1 ceramic and - 10 electrolytic	-	μF μF

2.5.3. Characteristics

at $T_A = 0$ to 65 °C, $V_{SUP1} = 4.75$ to 5.25 V, $V_{SUP2} = 11$ to 14 V,
 $f_{\emptyset M} = 5$ to 20 MHz

Symbol	Parameter	Pin No.	Min.	Typ.	Max.	Unit	Test Conditions
I_{SUP1}	Supply Current	2 + 13	-	25	-	mA	
I_{SUP2}	Supply Current	14	-	55	-	mA	
I_{AIDC}	Analog Input D.C. Current	12, 16	-	4.0	-	μ A	$V_{AI} = 5$ to 7 V
C_{AI}	Analog Input Capacitance		-	10	-	pF	
$-I_{SVIL}$	SV Video Select Input Low Current	10	-	50	-	μ A	$V_{SVI} = 0$
$-I_{UHIL}$	UH Undelayed Horizontal Blanking Pulse Input Low Current	11	-	50	-	μ A	$V_{UHI} = 0$
V_{VOL}	Video Output Low Voltage	3 to 9	-	-	2.0	V	$I_{VO} = 1$ mA
V_{VOH}	Video Output High Voltage		3.0	-	-	V	$-I_{VO} = 1$ mA
t_{VOT}	Video Output Transition Time		-	10	-	ns	
$t_{\emptyset MVOH}$	Video Output Hold Time after $\emptyset M$ Main Clock Input HL Transition	3 to 9, 18	15	-	30	ns	
V_{RA}	RA Upper Reference Potential for Analog Input A	15	6.8	7.0	7.2	V	
V_{RL}	Lower Reference Potential	13	-	V_{SUP1}	-	-	

2.5.4. Performance Characteristics

at $T_A = 0$ to 65 °C, $V_{SUP1} = 4.75$ to 5.25 V, $V_{SUP2} = 11$ to 14 V,
 $f_{\text{DM}} \cong 5$ to 20 MHz

Symbol	Parameter	Min.	Typ.	Max.	Unit
NL _D	Differential Non-Linearity	-	-	0.5	LSB
NL _I	Integral Non-Linearity	-	-	0.4	%
BW _{1dB}	Bandwidth, -1dB	20	-	-	MHz
CR	Conversion Rate	22	-	-	MHz
AJ	Aperture Jitter	-	-	100	ps
PE _D	Differential Phase Error	-	-	1.5	deg

Output Code

Analog Input Voltage Pin 12	Analog Input Voltage Pin 16	Digital Output Word Gray-coded (Pin 11 High)
5.000 000 V	5.000 000 0 V	0 0 0 0 0 0 0
5.015 625 V	5.007 812 5 V	0 0 0 0 0 0 1
5.031 250 V	5.015 625 0 V	0 0 0 0 0 1 1
5.046 875 V	5.023 437 5 V	0 0 0 0 0 1 0
5.062 500 V	5.031 250 0 V	0 0 0 0 1 1 0
....
6.984 375 V	5.992 187 5 V	1 0 0 0 0 0 1
7.000 000 V	6.000 000 0 V	1 0 0 0 0 0 0

2.5.5. Waveforms

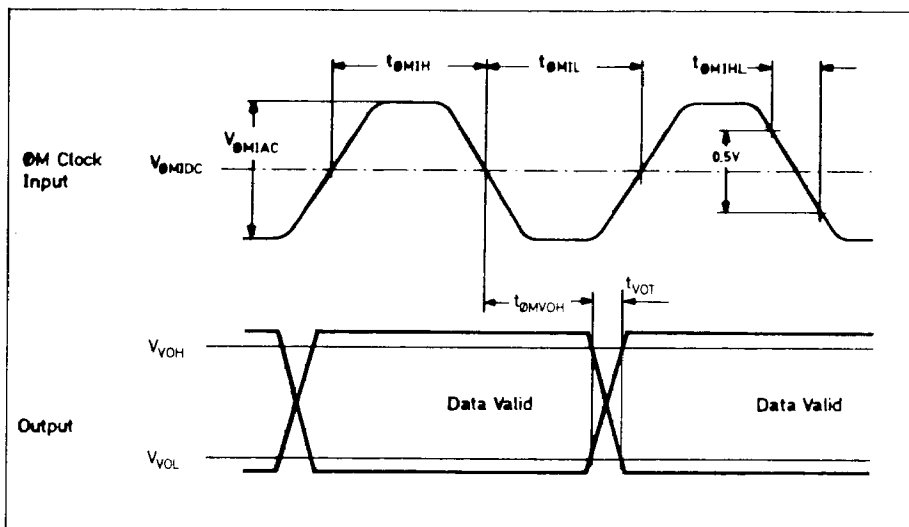

Fig. 2-6:
 Clock/data
 waveform



3. Functional Description

The fastest method of analog-to-digital conversion is by means of the so-called flash converter. A flash converter is made up of a number of comparators whose non-inverting inputs are connected in parallel to the input signal, and the inverting inputs are supplied with increasing reference potentials generated by a reference voltage divider (resistor chain). In the case of the VAD 2150, which is a 7-bit converter, $2^7 = 127$ comparators are assembled on the same chip (see Fig. 3-1). These comparators are sampled periodically, and their output signals give a thermometer-coded digital data word which is latched for further processing.

Following the latch is the code converter, which converts the thermometer code into the Gray code which ensures compatibility with the DIGIT 2000 system and improves the analog electrical characteristics. For some applications a simple-binary coded output word may be of advantage. In this case, the code conversion can be accomplished with an external PROM table.

Usually, a clamping circuit is required for the digitization of video signals. The VAD 2150 uses the method known from the DIGIT 2000 digital TV system and described in the DPU 2543 data sheet. The two input amplifiers following the analog inputs A and B have a low input capacitance which simplifies the analog driving circuit. Two different inputs are provided for selecting one of two different signal sources. The analog input B can be used for standard signals with 1 V amplitude, whereas analog input A requires double this voltage (2 V p-p). A High level at pin 10 "SV Video Select Input" activates input B, a low level activates input A.

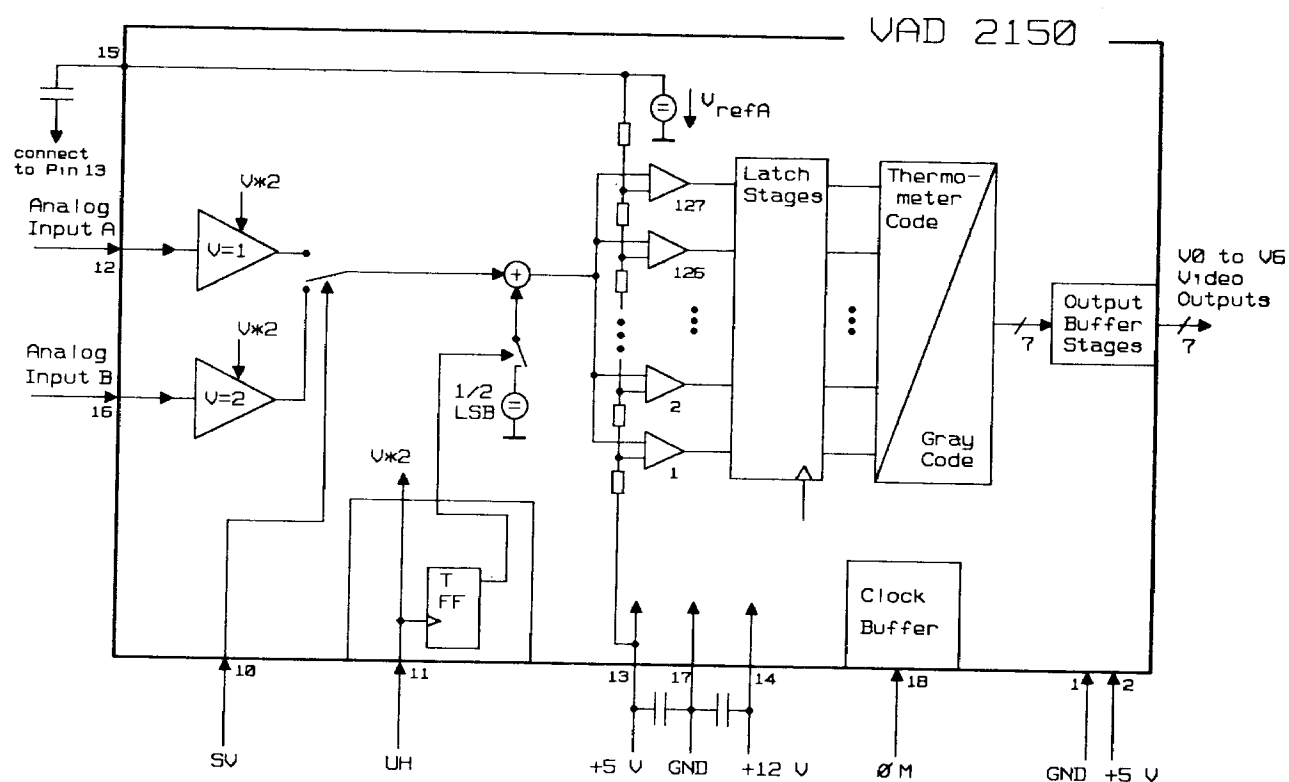

Fig. 3-1: VAD 2150 Block diagram

During the horizontal blanking time, it can be useful to double the video amplitude internally for increased resolution of the color subcarrier burst and sync pulse. This will improve the function of digital synchronization circuits. The horizontal blanking pulse (active Low) must be supplied externally to the "UH Undelayed Horizontal Blanking Pulse Input" pin 11 (normally by the VSP 2850 Video Sync Processor). If this option is not used, High level should be applied to pin 11.

A further option with the input circuitry is the pseudo 8-bit mode known from the DIGIT 2000 system. In connection with digital processing algorithms, it is used to increase the amplitude resolution of the video A/D conversion. The reference voltage of the A/D converter is different for odd and even lines by half an LSB. There is a flipflop toggled by the trailing edge of the horizontal blanking pulse, which is applied to the UH input pin 11.

The analog and the digital sections of the VAD 2150 Video A/D Converter have separate power supply pins to achieve a good decoupling between the analog and the digital circuitry.

**Production and
Marketing Centers:**

U.S.A.

ITT Semiconductors
55 Merrimack Street
Lawrence, MA 01843
Tel. (617) 688-1881
TWX 710-342-1357

W. Germany

INTERMETALL GmbH
P. O. Box 840
D-7800 Freiburg
Tel. (0761) 517-0
Telex 772 715

Japan

ITT Semiconductors FEL
P. O. Box 21
Shinjuku-ku
Tokyo 160-91
Tel. (03) 347 88 81-5
Telex 22 858

Reprinting is generally permitted, indicating the source. However, our consent must be obtained in all cases. Information furnished by ITT is believed to be accurate and reliable. However, no responsibility is assumed by ITT for its use; nor for any infringements of patents or other rights of third parties which may result from its use. No license is granted by implication or otherwise under any patent or patent rights of ITT. The information and suggestions are given without obligation and cannot give rise to any liability; they do not indicate the availability of the components mentioned. Delivery of development samples does not imply any obligation of ITT to supply larger amounts of such units to a fixed term. To this effect, only written confirmation of orders will be binding.

Printed in W. Germany · Imprimé dans la République Fédérale d'Allemagne by Rombach: Druckhaus KG, Freiburg i. Br.

Edition 1987/7 · Order No. 6251-281-3E

