

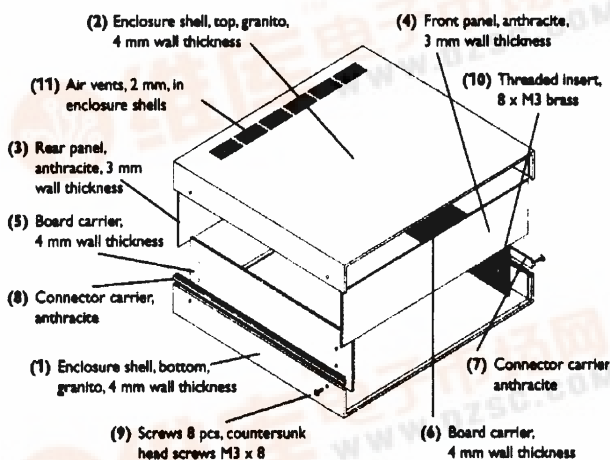

BIM 9000 SERIES

- Two-tone enclosure system, functional and user-friendly
- Material: recyclable polystyrene (PS), fine-grain surface
- Each part can be finished using customary tools
- Board carrier panels to receive PCBs (as per DIN 41494 part 2) comprising guiding grooves (2.0 mm wide 2.0 mm deep) in 5.08 mm pitch, horizontal and vertical.

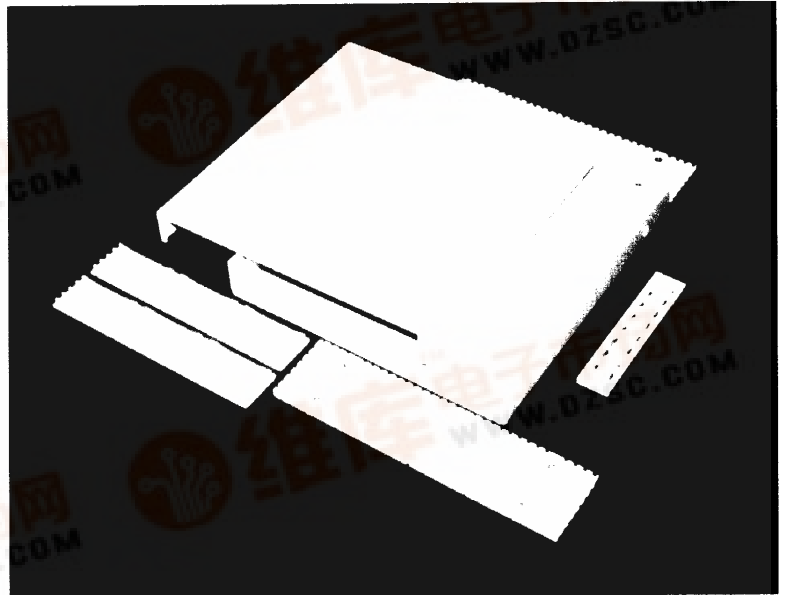

Assembly is very simple:

Start with bottom enclosure shell (1)

Insert front panel (4) and rear panel (3) vertically

Insert board carrier panels (5 + 6) and screw (9) to bottom of enclosure shell (1)

Insert connector carriers (7 + 8) on both sides

Mount top enclosure shell (2), engage in connector carriers (7 + 8) by applying slight pressure and secure with screws (9).