

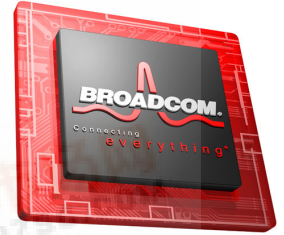

BCM2042 PRODUCT Brief



SINGLE-CHIP BLUETOOTH® MOUSE AND KEYBOARD

FEATURES

- Single-chip Bluetooth® device with fully integrated Human Interface Device (HID) profile and full Bluetooth stack
- On-board 8051 processor and RAM/ROM memory
- Custom-integrated Bluetooth core processor has been optimized to support the HID v1.0 profile and minimize power consumption
- Bluetooth version 2.0 compliant including support for adaptive frequency hopping and fast connect
- Fully integrated radio eliminates all filters and matching components and features a single-pin interface directly to antenna
- Direct interface to keyboard scan matrix with full support for up to 8 x 20 keys and user-customizable hot keys
- Integrated quadrature signal decoder to support both ball and optical mouse designs
- Direct interface to LED and LCD displays
- Drive capability to power external optoelectronics
- ROM-based design eliminates external flash memories
 - Flash option offered to support feature development
- Fully integrated low dropout (LDO) regulator provides direction interface to batteries
- Integrated switching regulator to support external sensor and more to further reduce BOM cost
- Available in 88-pin fpBGA and 120-pin fpBGA packages

SUMMARY OF BENEFITS

- Cost-optimized solution for mouse and keyboard applications
 - Achieves lowest possible cost through the integration of all external components
 - Direct interface to key scan matrix or ball/optical mouse encoders
- Replaces existing mouse or keyboard processor and memory and adds Bluetooth functionality
- Lowest power consumption solution provides greater than six-month battery life
- Adaptive frequency hopping support ensures full interoperability and coexistence with WLAN enabled personal computers
- Optimized radio provides long-range, interference-free operation in high-interference environments
 - Transmitter provides +4 dBm output power and satisfies Class 2 operation
 - Receiver provides -85 dBm receiver sensitivity
- Single monolithic bulk CMOS device providing low cost and high availability of manufacturing supply

APPLICATIONS

- Bluetooth mouse
- Bluetooth keyboard
- Combination mouse/keyboard
- Remote control HID devices
- Game controllers

BCM2042 Functional Block Diagram

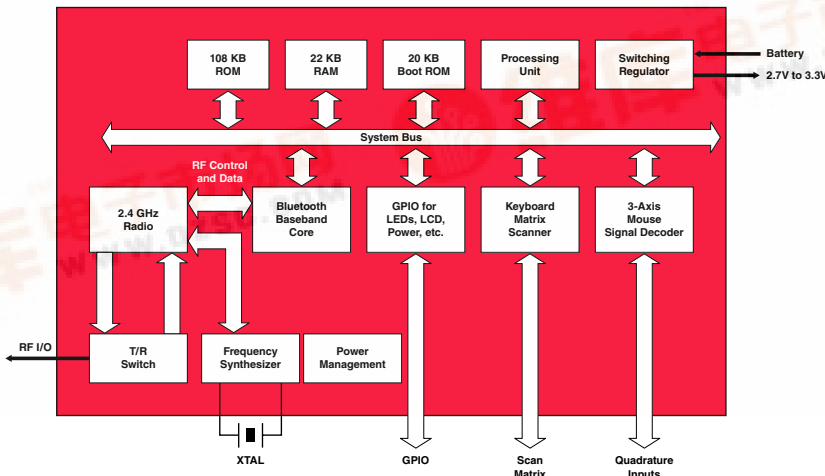

OVERVIEW

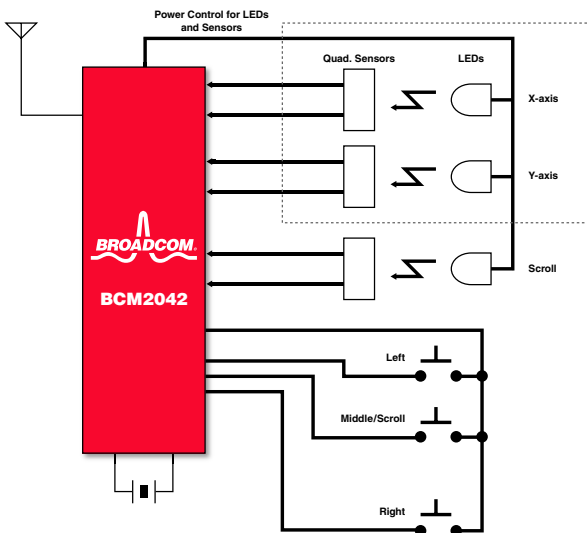

BCM2042 Mouse Block Diagram

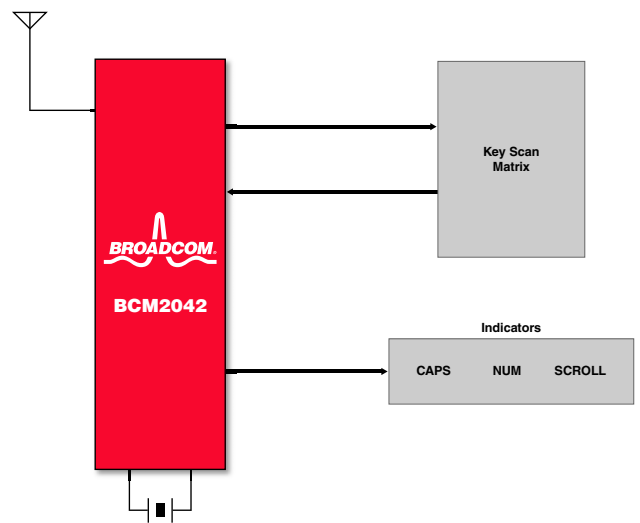

BCM2042 Keyboard Block Diagram

The BCM2042 is a major breakthrough in the design of low-cost Bluetooth mouse and keyboard devices. The BCM2042 is a true single chip that integrates the entire profile, application, and Bluetooth protocol stack and is fully compliant with the Bluetooth SIG specification for human interface devices. The BCM2042 is fully compliant with the version 2.0 Bluetooth specification, including adaptive frequency hopping and fast connection, which are essential to mouse and keyboard applications in personal computers.

Integration is key to achieving the system cost targets of today's PC OEMs. By integrating all components within today's mouse and keyboard into the BCM2042, low system costs can be achieved to approach the price points of legacy-wired mice and keyboards. The BCM2042 can interface directly to mouse optical or ball encoders and keyboard scan matrices.

A key component enabling the BCM2042 to reach extremely low system cost is the inclusion of a high-performance boost regulator. This enables direct connect with mouse electronics requiring 3-volt operation without adding expensive external components

The Bluetooth baseband core has been optimized to maximize the battery life and functionality required for a mouse or keyboard application. Battery life has been optimized in the BCM2042 to meet greater than 6 months for the typical user using standard battery technology.

The BCM2042 integrates a high-performance radio implemented in standard bulk CMOS. It incorporates a proprietary self-calibrating VCO structure for both excellent phase noise and fast frequency hopping covering the entire band. All filters have been fully integrated into the device and are also self-calibrating to automatically compensate for changes in temperature and any process variation during manufacturing. The RF interface to the device fully integrates the T/R switch and its associates matching circuits, enabling direct interface with the antenna.

The block diagrams show how the BCM2042 can be used in either a mouse or keyboard application.

Broadcom®, the pulse logo, Connecting everything®, and the Connecting everything logo are among the trademarks of Broadcom Corporation and/or its affiliates in the United States, certain other countries and/or the EU. Any other trademarks or trade names mentioned are the property of their respective owners. Bluetooth® is a trademark owned by Bluetooth SIG.

Connecting
everything®



BROADCOM CORPORATION
16215 Alton Parkway, P.O. Box 57013
Irvine, California 92619-7013

© 2014 Broadcom Corporation. All rights reserved.

Phone: 949-450-8700
Fax: 949-450-8710
E-mail: info@broadcom.com
Web: www.broadcom.com