

# TO-92 Plastic Package Transistors (NPN)

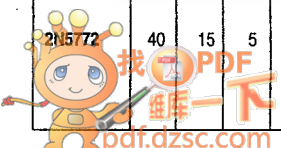

Maximum Ratings							Electrical Characteristics (Ta=25°C, Unless Otherwise Specified)															
Type No.	V <sub>CBO</sub> (V)	V <sub>CED</sub> (V)	V <sub>EBO</sub> (V)	P <sub>D</sub> (W)	I <sub>C</sub> (A)	I <sub>CBO</sub> (μA)	V <sub>CB</sub> (V)	I <sub>BES</sub> (μA)	V <sub>CE</sub> (V)	h <sub>FE</sub>	I <sub>C</sub> & V <sub>CE</sub>	V <sub>CE(SAT)</sub> (V)	V <sub>BE(SAT)</sub> (V)	I <sub>C</sub> (mA)	C <sub>ob</sub> (pF)	f <sub>i</sub> (MHz)	t <sub>on</sub> (ns)	N <sub>F</sub> (dB)	C <sub>ie</sub> (pF)	CDIL Case Style		
	Min	Min	Min	@ Tc=25°C		Max	@ (V)	Max	@ (V)	Min Max	(mA) (V)	Max Min Max	@ (mA)	Typ Max	Min Typ Max	Max	Max	Max	Max			
2N5088	35	30	5	0.625	0.05	0.05	20			300	10 5	0.5		10	4	50					TO-92	
										350	1 5											
										300	900 0.1 5											
2N5127	20	12	3	0.625	0.05	0.05	10			15	300 2 10	0.3	1	10	3.5	150					TO-92	
2N5128	15	12	3	0.6	0.5	0.05	10			35	350 50 10	0.25	1.1	150	10	200					TO-92	
										20	10 10											
2N5129	15	12	3	0.6	0.5	0.05	10			35	350 50 10	0.25	1.1	150	10	200					TO-92	
										20	10 10											
2N5130	30	12	1	0.625	0.05	0.05	10			15	250 8 10	0.6	1	10	1.7	450					TO-92	
2N5131	20	15	3	0.625	0.1	0.05	10			35	500 10 1	1		10	6	100					TO-92	
2N5132	20	20	3	0.625	0.1	0.05	10			30	400 10 10	2	0.9	10	3.5	200					TO-92	
2N5133	20	18	3	0.625	0.05	0.05	15			60	1000 1 5	0.4		1	5						TO-92	
2N5134	20	10	4	0.625	0.2	0.1	15			15	30 0.4	0.25	0.7	0.9	4	250			18		TO-92	
										20	150 10 1											
2N5135	30	25	4	0.6	0.5	0.3	15			50	60 10 10	1	1	100	25	40					TO-92	
										15	2 10											
2N5136	30	20	3	0.6	0.5	0.1	20			20	400 150 1	0.25	1.1	150	35	40					TO-92	
										20	30 1											
2N5137	30	20	3	0.6	0.5	0.1	20			20	400 150 1	0.25	1.1	150	35	40					TO-92	
										20	30 1											
2N5172	25	25	5	0.4	0.15	0.1	25			100	500 10 10	0.25		10	10						TO-92-1	
2N5219	20	15	3	0.625	0.1	0.1	10			35	500 2 10	0.4	1	10	4	150					TO-92	
2N5220	15	15	3	0.625	0.6	0.1	10			30	600 50 10	0.5	1.1	150	10	100					TO-92	
										25	10 10											
2N5223	25	20	3	0.625	0.1	0.1	10			50	800 2 10	0.7	1.2	10	4	150					TO-92	
2N5224	25	12	5	0.625	0.2	0.5	15			15	100 1 0.35	0.9		10	4	250					TO-92	
										40	10 1											
2N5225	25	25	4	0.625	0.6	0.3	15			30	600 50 10	0.8	1	100	20	50					TO-92	
										25	10 10											
2N5232		50		0.625	0.05	0.03	50			250	500 2 5	0.125		10	4						TO-92-1	
2N5232A		50		0.625	0.05	0.03	50			250	500 2 5	0.125		10	4				5		TO-92-1	
2N5449	50	30	5			0.1	20			100	300 100 2	0.6		100		5					TO-92-4	
2N5550	160	140	6	0.5	0.6	0.1	100			20	50 5	0.15	1	10	6	100				10	TO-92	
										60	250 10 5	0.25	1.2	50								
										60	1 5											
2N5551	180	160	6	0.5	0.6	0.05	120			30	50 5	0.15	1	10	6	100				8	TO-92	
										80	250 10 5	0.2	1	50								
										80	1 5											
2N5772	40	15	5	0.625	0.3	0.5	20			15	300 1	0.2	0.75	0.95	5	350				30	28	TO-92
										25	100 0.5	0.28	0.75	1.2	100							
										30	120 30 0.4	0.5	0.75	1.7	300							



# TO-92 Taping Details

MECHANICAL DATA

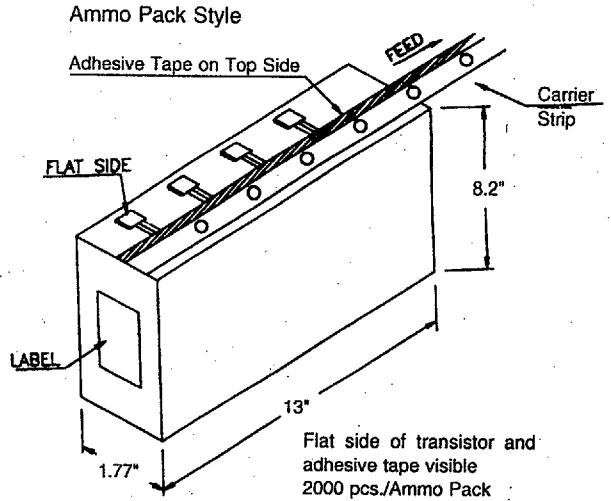
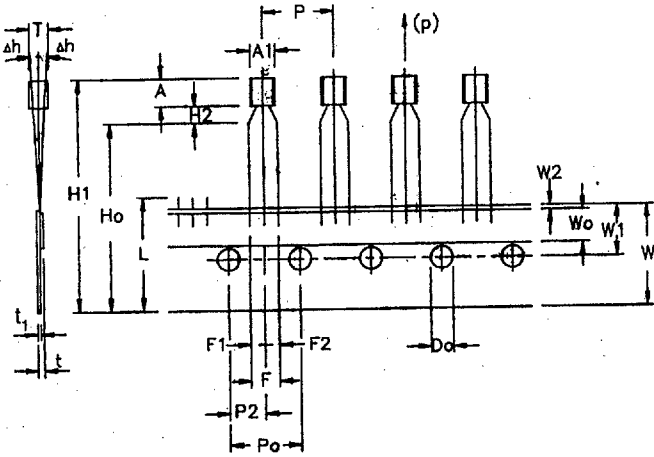

Item	Symbol	Specification				Remarks
		Min.	Nom.	Max.	Tol.	
Body Width	A1	4.0		4.8		
Body Height	A	4.8		5.2		
Body Thickness	T	3.9		4.2		
Pitch of Component	P		12.7		±1	
Feed Hole Pitch	Po		12.7		±0.3	Cumulative Pitch Error 1.0 mm/20 Pitch
Feed Hole Centre to Component Centre	P2		6.35		±0.4	To be measured at bottom of Clinch
Distance between Outer Leads	F		5.08		±0.6	
Component Alignment	Δh		0	1	-0.2	At Top of Body
Tape Width	W		18		±0.5	
Hold-Down Tape Width	W0		6		±0.2	
Hole Position	W1		9		±0.7	
Hold-Down Tape Position	W2		0.5		±0.2	
Lead Wire Clinch Height	Ho		16		±0.5	
Component Height	H1			32.25		
Length of Snipped leads	L			11.0		
Feed Hole Diameter	Do		4		±0.2	
Total Tape Thickness	t			1.2		t <sub>1</sub> 0.3-0.6
Lead-to-Lead Distance	F1,F2		2.54		+0.4 -0.1	
Clinch Height	H2			3		
Pull-out Force	(p)	6N				

Dimensions in m.m.

- Notes:
1. Maximum alignment deviation between leads not to be greater than 0.2 mm.
  2. Maximum non-cumulative variation between tape feed holes shall not exceed 1 mm in 20 pitches
  3. Hold-down tape not to exceed beyond the edge(s) of carrier tape and there shall be no exposure of adhesive.
  4. No more than 3 consecutive missing components permitted.
  5. A tape trailer, having at least three feed holes is required after the last component.
  6. S<sub>f</sub> sprocket feed holes.

