



UNISONIC TECHNOLOGIES CO.,

P3596

LINEAR INTEGRATED CIRCUIT

150KHZ, 3A PWM STEP-DOWN DC/DC CONVERTER

DESCRIPTION

The UTC **P3596** series is a step-down switching regulator able to provide **3A** output current. The available output voltages are **3.3V, 5V, 12V, and an adjustable** output version.

FEATURES

- *Output load current: **3A**
- *Adjustable version output voltage range, 1.23V ~ 37V±4%
- *Operating voltage can be up to **40V** (Vin->40V)
- *Low power standby mode
- *High efficiency
- *Internal current and thermal limit

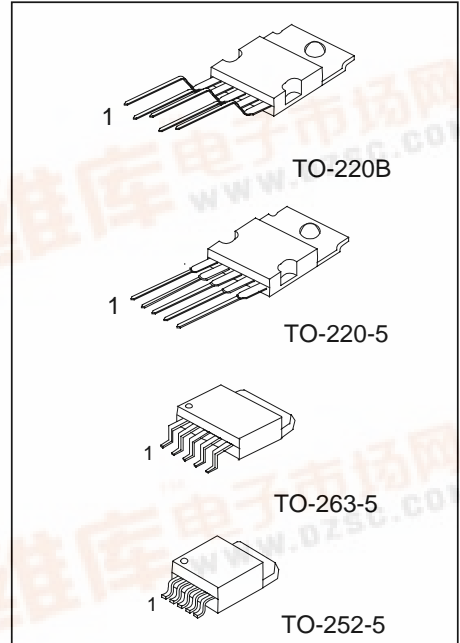

*Pb-free plating product number:P3596L

PIN DESCRIPTION

PIN NO.	PIN NAME	DESCRIPTION
1	V _{IN}	Operating voltage input
2	Output	Switching output
3	GND	Circuit Ground
4	FB (Feedback)	Output voltage feedback control
5	SD (Shutdown)	ON/OFF shutdown

ORDERING INFORMATION

P3596□-□-□-□
(1) (2) (3) (4)

(1)		(2)		(3)		(4)	
Plating		Output Voltage		Package		Packing	
Type	Code	Vout	Code	Type	Code	Type	Code
Pb/Sn		12V	12	TO-252-5	TN5	Tape Reel	R
Pb-Free	L	5.0V	50	TO-220-5	TA5	Tube	T
		3.3V	33	TO-220B	TB5	Tube	T
		3.0V	30	TO-263-5	TQ5	Tape Reel	R
		Adj	AD				

P3596

LINEAR INTEGRATED CIRCUIT

■ BLOCK DIAGRAM

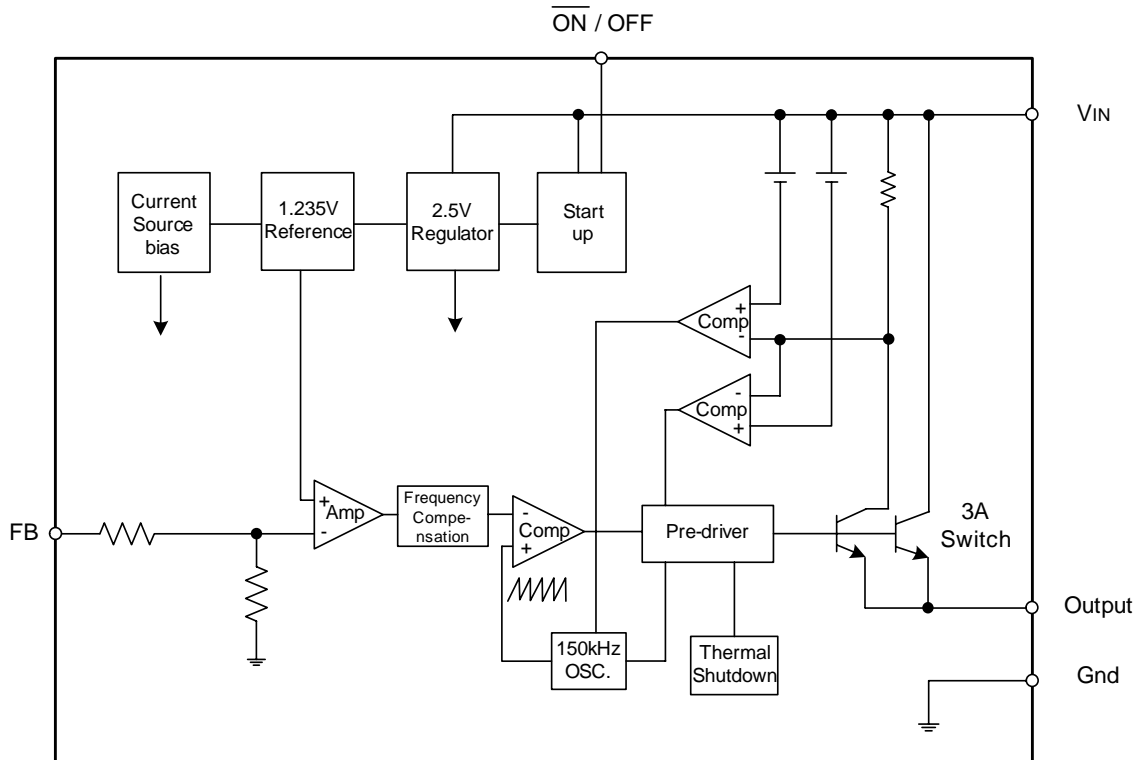

■ TYPICAL APPLICATION

(Fixed Output Voltage Versions)

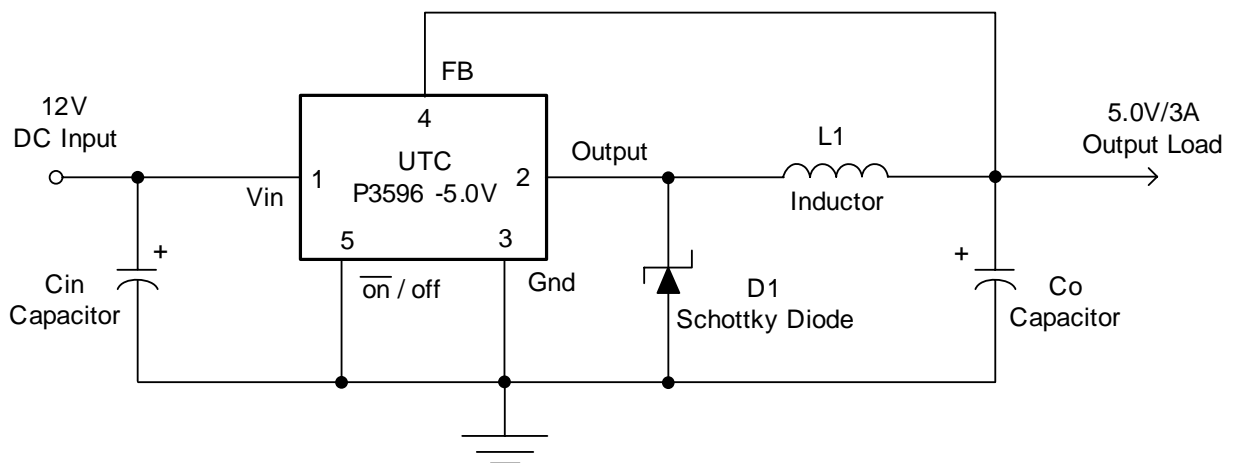

■ ADJUSTABLE OUTPUT VOLTAGE VERSIONS

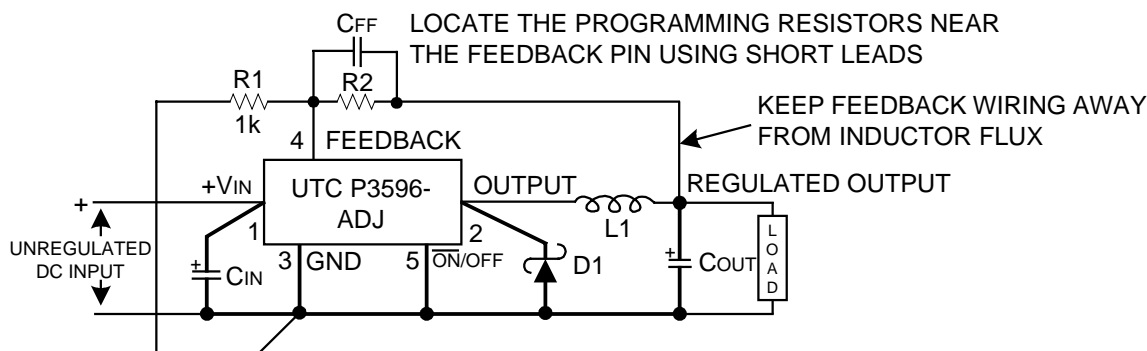

$$V_{out} \times \left(\frac{R1}{R1 + R2} \right) = V_{ref}$$

$$V_{out} = V_{ref} \left(1 + \frac{R2}{R1} \right)$$

Where $V_{ref} = 1.23V$

$$R2 = R1 \left(\frac{V_{out}}{V_{ref}} - 1 \right)$$

■ ABSOLUTE MAXIMUM RATINGS

PARAMETER	SYMBOL	RATINGS	UNIT
Maximum Supply Voltage	V_{CC}	45	V
Operating Voltage	V_{OPR}	4.5 ~ 40	V
ON/OFF Pin Input Voltage	$V_{ON/OFF}$	-0.3 ~ +25	V
Feedback Pin Voltage	V_{FB}	-0.3 ~ +25	V
Output Voltage to Ground (Steady State)	V_{OUT}	-1	V
Power Dissipation	P_D	Internally limited	mW
Maximum Junction Temperature	T_J	+150	°C
Temperature Range	T_{OPR}	-40 ~ +125	°C
Storage Temperature Range	T_{STG}	-40 ~ +150	°C

■ THERMAL DATA

PARAMETER	SYMBOL	RATINGS	UNIT
Thermal Resistance Junction to Case	θ_{Jc}	TO-220B	3
		TO-220-5	3
		TO-263-5	4
		TO-252-5	8
Thermal Resistance Junction to Ambient	θ_{JA}	TO-220B	45
		TO-220-5	45
		TO-263-5	55
		TO-252-5	90

P3596

LINEAR INTEGRATED CIRCUIT

■ ELECTRICAL CHARACTERISTICS

(T_j=25°C, V_{IN}=12V for the 3.3V, 5V, and Adjustable version and V_{IN}=24V for the 12V version, I_{LOAD}=500mA.)

PARAMETER	SYMBOL	TEST CONDITIONS	MIN	TYP	MAX	UNIT
Output Voltage	3.3V	4.75V ≤ V _{IN} ≤ 40V, 0.2A ≤ I _{LOAD} ≤ 3A	3.168	3.3	3.432	V
	5.0V	7V ≤ V _{IN} ≤ 40V, 0.2A ≤ I _{LOAD} ≤ 3A	4.8	5.0	5.2	V
	12V	15V ≤ V _{IN} ≤ 40V, 0.2A ≤ I _{LOAD} ≤ 3A	11.52	12.0	12.48	V
Efficiency	3.3V	V _{IN} =12V, I _{LOAD} =3A		73		%
	5.0V	V _{IN} =12V, I _{LOAD} =3A		80		%
	12V	V _{IN} =25V, I _{LOAD} =3A		90		%
UTC P3596-ADJ						
Feedback Voltage	V _{FB}	4.5V ≤ V _{IN} ≤ 40V, 0.2A ≤ I _{LOAD} ≤ 3A V _{OUT} programmed for 3V	1.193	1.230	1.267	V
Efficiency	η	V _{IN} =12V, V _{OUT} =3V, I _{LOAD} =3A		73		%
ALL OUTPUT VOLTAGE						
Feedback Bias Current	I _b	Adjustable Version Only, V _{FB} =1.3V		10	50	nA
Oscillator Frequency	f _o	(Note 1)	127	150	173	kHz
Saturation Voltage	V _{SAT}	I _{OUT} =3A (Note 2, 3)		1.16	1.4	V
Max Duty Cycle (ON)	DC	(Note 3)		100		%
Min Duty Cycle (OFF)		(Note 4)		0		
Current Limit	I _{CL}	Peak Current (Notes 2, 3)	3.6	4.5	6.9	A
Output Leakage Current	I _L	Output=0V (Notes 2, 4)			50	μA
		Output=-1V (Note 5)		2	30	mA
Quiescent Current	I _Q	(Note 4)		5	10	mA
Standby Quiescent Current	I _{STBY}	ON/OFF pin=5V (OFF) (Note 5)		80	200	μA
ON/OFF CONTROL						
ON/OFF Pin Logic Input Threshold Voltage	V _{IH} V _{IL}	Low (Regulator ON) High (Regulator OFF)	2.0	1.3 1.3	0.6	V
ON/OFF Pin Input Current	I _H	V _{LOGIC} =2.5V (Regulator OFF)		5	15	μA
	I _L	V _{LOGIC} =0.5V (Regulator ON)		0.02	5	μA

Note 1: The switching frequency is reduced when the second stage current limit is activated.

Note 2: No diode, inductor or capacitor connected to output pin.

Note 3: Feedback pin removed from output and connected to 0V to force the output transistor switch ON.

Note 4: Feedback pin removed from output and connected to 12V for the 3.3V, 5V, and the ADJ. version, and 15V for the 12V version, to force the output transistor switch OFF.

Note 5: V_{IN} = 40V

TYPICAL CHARACTERISTICS

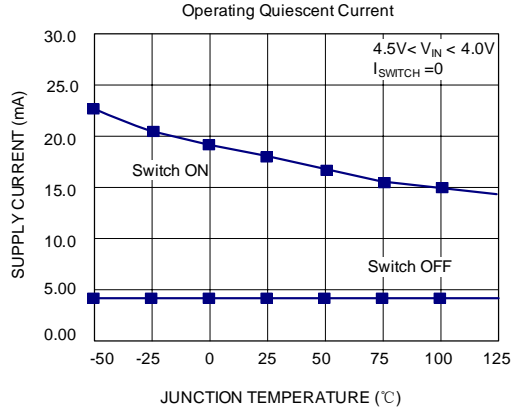
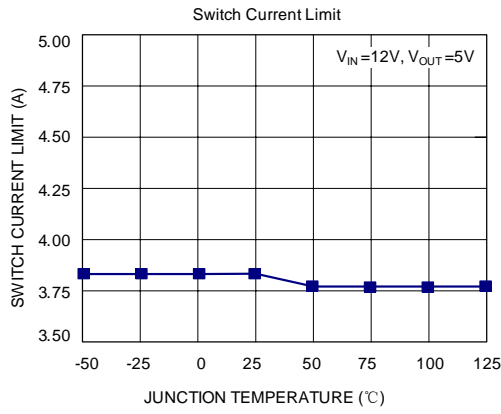
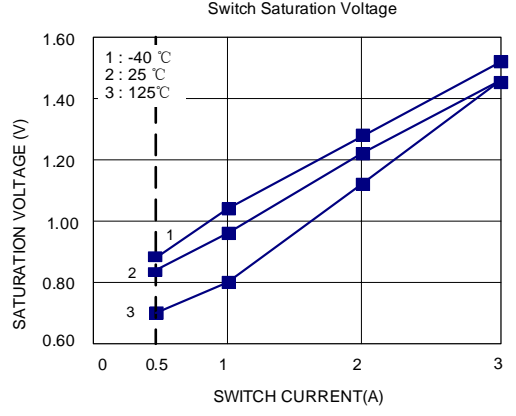
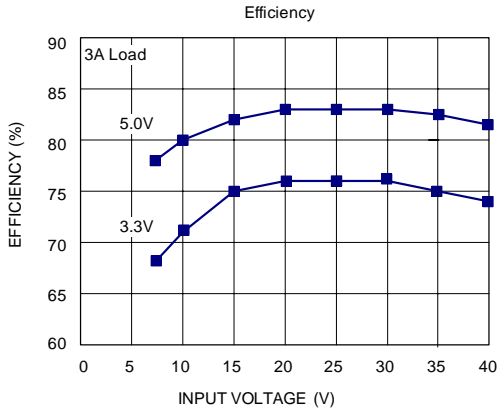
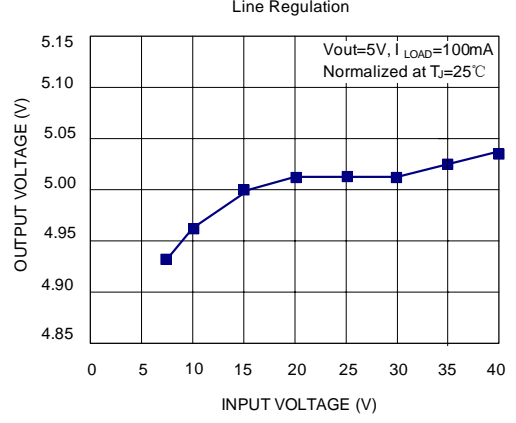
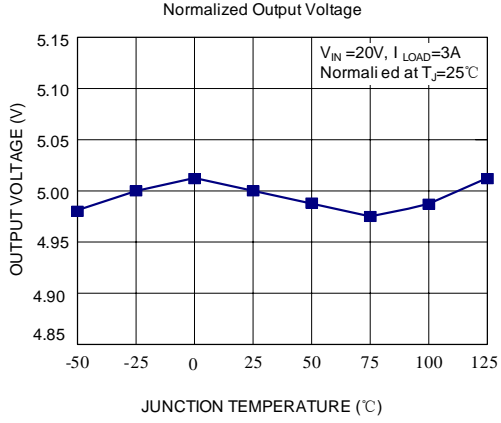

TYPICAL CHARACTERISTICS (cont.)

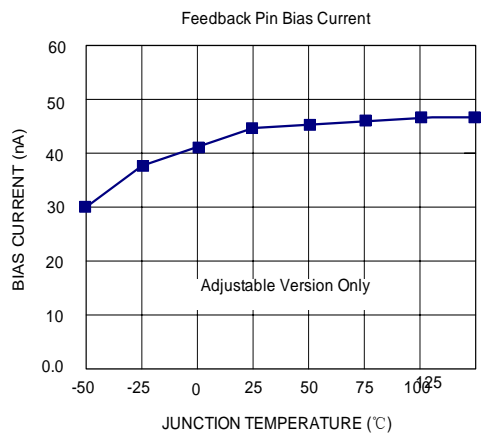
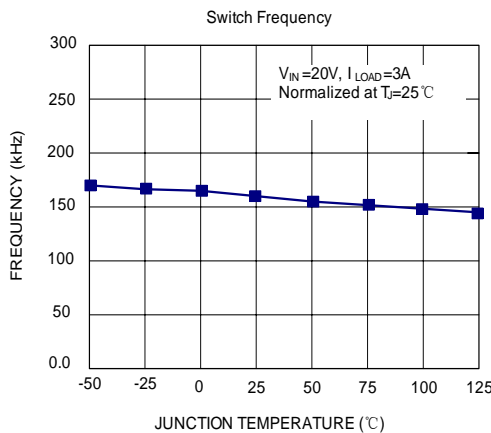
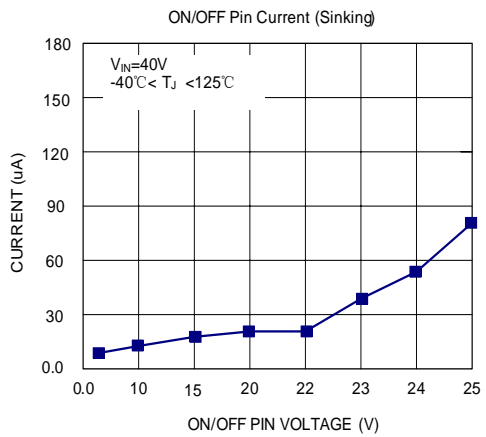
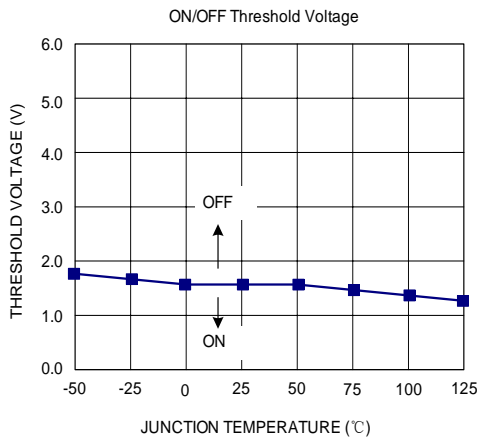
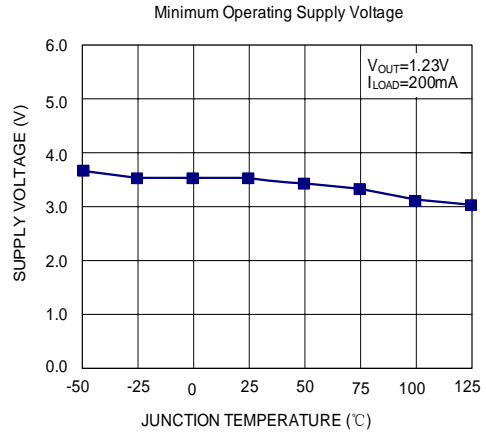
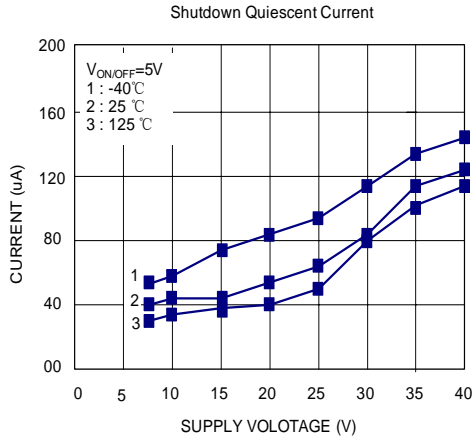

UTC assumes no responsibility for equipment failures that result from using products at values that exceed, even momentarily, rated values (such as maximum ratings, operating condition ranges, or other parameters) listed in products specifications of any and all UTC products described or contained herein. UTC products are not designed for use in life support appliances, devices or systems where malfunction of these products can be reasonably expected to result in personal injury. Reproduction in whole or in part is prohibited without the prior written consent of the copyright owner. The information presented in this document does not form part of any quotation or contract, is believed to be accurate and reliable and may be changed without notice.