

MC14412

CMOS LSI

(LOW-POWER COMPLEMENTARY MOS)

UNIVERSAL LOW SPEED (0-600 bps) MODEM

UNIVERSAL LOW SPEED MODEM (0-600 bps)

The MC14412 contains a complete FSK (Frequency-Shift Keying) modulator and demodulator compatible with both foreign (C.C.I.T.T. standards) and U.S.A. low speed (0 to 600 (bps) communication networks.

- On-Chip Crystal Oscillator with External Crystal
- Echo Suppressor Disable Tone Generator
- Originate and Answer Modes
- Simplex, Half-Duplex, and Full-Duplex Operation
- On-Chip Sine Wave Generator
- Modem Self Test Mode
- Single Supply:
 $V_{DD} = 4.75$ to 15 Vdc MC14412FP, MC14412 FL
 $V_{DD} = 4.75$ to 6.0 Vdc MC14412VP, MC14412VL
- Selectable Data Rates: 0-300, 0-600 bps
- Post Detection Filter
- TTL or CMOS Compatible Inputs and Outputs

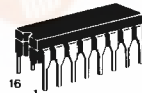

L SUFFIX
CERAMIC PACKAGE
CASE 620

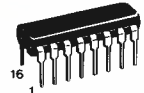

P SUFFIX
PLASTIC PACKAGE
CASE 648

ORDERING INFORMATION

MC144XX	Suffix	Denotes
	L	Ceramic Package
	P	Plastic Package
	F	4.75 to 15 Vdc
	V	4.75 to 6.0 Vdc

BLOCK DIAGRAM

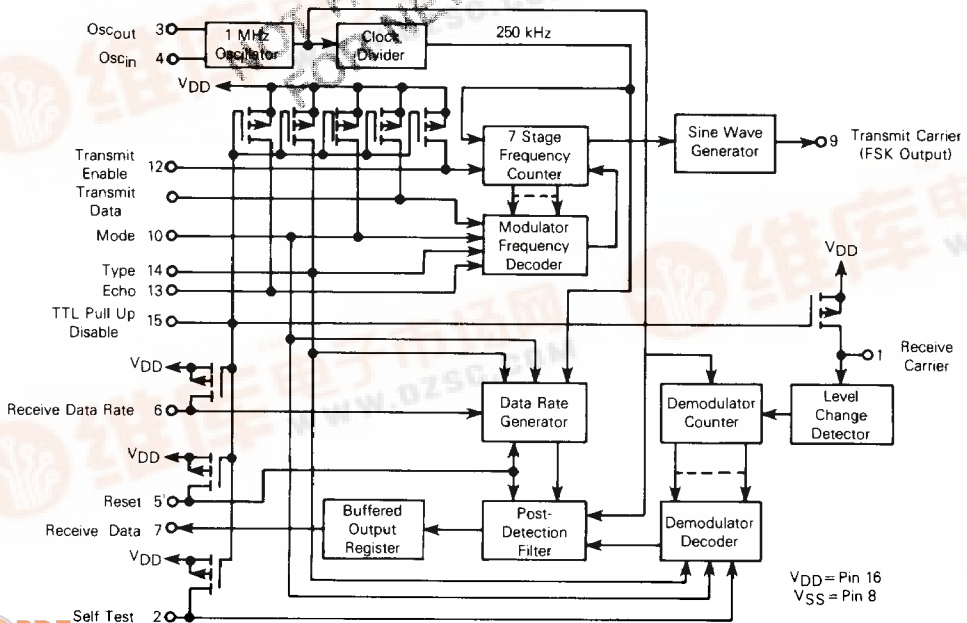

$V_{DD} = \text{Pin } 16$
 $V_{SS} = \text{Pin } 8$

ELECTRICAL CHARACTERISTICS

Characteristic	Symbol	VDD** Vdc	-40°C		+25°C			+86°C		Unit
			Min	Max	Min	Typ	Max	Min	Max	
Output Voltage Pin 7 Only "0" Level $V_{in} = V_{DD}$ or 0 "1" Level $V_{in} = 0$ or V_{DD}	VOL	5.0	—	0.05	—	0	0.05	—	0.05	V
		10	—	0.05	—	0	0.05	—	0.05	
		15	—	0.05	—	0	0.05	—	0.05	
	VOH	5.0	4.95	—	4.95	5.0	—	4.95	—	V
		10	9.95	—	9.95	10	—	9.95	—	
		15	14.95	—	14.95	15	—	14.95	—	
Input Voltage* "0" Level ($V_O = 4.5$ or 0.5 V) ($V_O = 9.0$ or 1.0 V) ($V_O = 13.5$ or 1.5 V) "1" Level Pin 15 ($V_O = 0.5$ or 4.5 V) ($V_O = 1.0$ or 9.0 V) ($V_O = 1.5$ or 13.5 V)	VIL	5.0	—	1.5	—	2.25	1.5	—	1.5	V
		10	—	3.0	—	4.50	3.0	—	3.0	
		15	—	4.0	—	6.75	4.0	—	4.0	
	VIH	5 to 15	$V_{DD} - 0.75$	—	$V_{DD} - 0.8$	$V_{DD} - 2$	—	$V_{DD} - 0.85$	—	V
		5.0	3.5	—	3.5	2.75	—	3.5	—	
		10	7.0	—	7.0	5.50	—	7.0	—	
15	11.0	—	11.0	8.25	—	11.0	—	—		
Output Drive Current Pin 7 Only ($V_{OH} = 2.5$) ($V_{OH} = 9.5$) ($V_{OH} = 13.5$) ($V_{OL} = 0.4$) ($V_{OL} = 0.5$) ($V_{OL} = 1.5$)	IOH	5	-0.62	—	-0.5	-1.5	—	-0.35	—	mA
		10	-0.62	—	-0.5	-1.0	—	-0.35	—	
		15	-1.8	—	-1.5	-3.6	—	-1.1	—	
	IOL	4.75	2.3	—	2.0	4.0	—	1.6	—	mA
		10	5.3	—	4.5	10	—	3.6	—	
		15	15	—	13	35	—	10	—	
Input Current (Pin 15 = V_{DD})	Iin	—	—	—	± 0.00001	± 0.1	—	—	μ A	
Input Pull-Up Resistor Source Current (Pin 15 = V_{SS} , $V_{in} = 2.4$ Vdc) Pins 1, 2, 5, 6, 10, 11, 12, 13, 14	Ip	5	285	—	250	460	—	205	—	μ A
Input Capacitance	Cin	—	—	—	—	5.0	—	—	—	pF
Total Supply Current (Pin 15 = V_{DD})	IT	5	—	4.5	—	1.1	4.0	—	3.5	mA
		10	—	13	—	4.0	12	—	11	
		15	—	27	—	8.0	25	—	23	
Modulator/Demodulator Frequency Accuracy (Excluding Crystal)	ACC	5 to 15	—	—	—	0.5	—	—	—	%
Transmit Carrier Output 2nd Harmonic	V2H	5	—	—	-20	-25	—	—	—	dB
		15	—	—	-25	-32	—	—	—	
Transmit Carrier Output Voltage ($R_L = 100$ k Ω) (Pin 9)	Vout	5	—	—	0.2	0.30	—	—	—	VRMS
		10	—	—	0.5	0.85	—	—	—	
		15	—	—	1.0	1.5	—	—	—	
Maximum Receive Carrier Rise and Fall Times (Pin 1)	tr, tf	5	—	15	—	—	15	—	15	μ s
		10	—	5.0	—	—	5.0	—	5.0	
		15	—	4.0	—	—	4.0	—	4.0	
Maximum Oscillator Frequency	fmax	5	—	—	1.2	5	—	—	—	MHz
Minimum Clock Pulse Width	tw	5	—	—	—	50	350	—	—	ns

*DC Noise Immunity (V_{IL} , V_{IH}) is defined as the maximum voltage change from an ideal "0" or "1" input level, that the circuit will withstand before accepting an erroneous input.

**Note: Only 5-Volt specifications apply to MC14412VP devices.

MC14412

2

MAXIMUM RATINGS (Voltages referenced to V_{SS} , Pin 8)

Rating	Symbol	Value	Unit
DC Supply Voltages MC14412FP, FL MC14412VP, VL	V_{DD}	-0.5 to 15 -0.5 to 6.0	V
Input Voltages, All Inputs	V_{in}	$V_{DD} + 0.5$ to $V_{SS} - 0.5$	V
DC Current Drain per Pin (except Pin 8, 7)	I	10	mA
DC Current Drain (Pin 8, 7)	I	35	mA
Operating Temperature Range	T_A	-40 to +85	°C
Storage Temperature Range	T_{stg}	-65 to +150	°C

This device contains circuitry to protect the inputs against damage due to high static voltages or electric fields; however, it is advised that normal precautions be taken to avoid application of any voltage higher than maximum rated voltages to this high impedance circuit. For proper operation it is recommended that V_{in} and V_{out} be constrained to the range $V_{SS} \leq (V_{in} \text{ or } V_{out}) \leq V_{DD}$.

Unused inputs must always be tied to an appropriate logic voltage level (e.g., either V_{SS} or V_{DD}).

PIN ASSIGNMENT

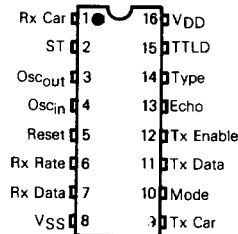

DEVICE OPERATION

GENERAL

Figure 1 shows the modem in a system application. The data to be transmitted is presented in serial format to the modulator for conversion to FSK signals for transmission over the telephone network. The modulator output is buffered/amplified before driving the 600 ohm telephone line.

The FSK signal from the remote modem is received via the telephone line and filtered to remove extraneous signals such as the local Transmit Carrier. This filtering can be either a bandpass which passes only the desired band of frequencies or a notch which rejects the known interfering signal. The desired signal is then limited to preserve the axis crossings and fed to the demodulator where the data is recovered from the received FSK carrier.

INPUT/OUTPUT FUNCTIONS

Figure 2 shows the I/O interface for the MC14412 low-

speed modem. The following is a description of each individual signal.

TYPE (Pin 14)

The Type input selects either the U.S. or C.C.I.T.T. operational frequencies for both transmitting and receiving data. When the Type input = "1", the U.S. standard is selected and when the Type input = "0", the C.C.I.T.T. standard is selected.

TRANSMIT DATA (Tx Data, Pin 11)

Transmit Data is the binary information input. Data entered for transmission is modulated using FSK techniques. When operating in the U.S. standard (Type = "1") a logic "1" input level represents a Mark or when operating in the CCITT standard (Type = "0") a logic "1" input level represents a Mark.



FIGURE 1 — TYPICAL LOW-SPEED MODEM APPLICATION

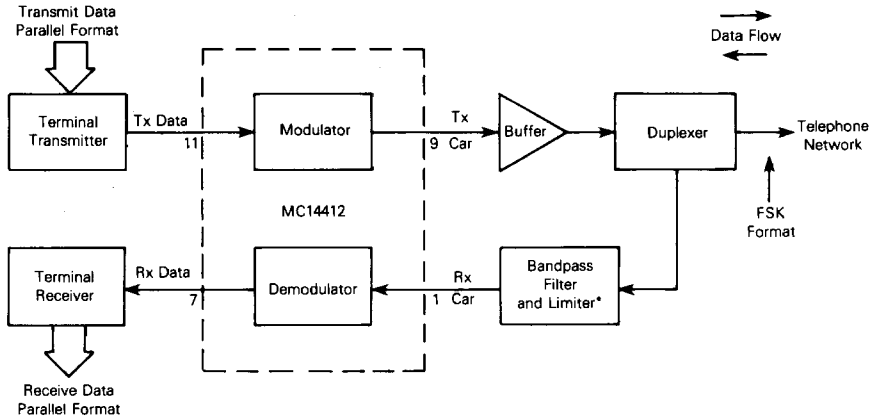

Since the modulator and demodulator sections of the MC14412 are functionally equivalent to those of the MC6860, additional application information can be obtained from the following Motorola publications:

- AN-731 Low-speed Modem Fundamentals
- AN-747 Low-speed Modem System Design Using the MC6860
- EB-49 Application Performance of the MC6860 MODEM.

FIGURE 2 — MC14412 INPUT/OUTPUT SIGNALS

*CRYSTAL SPECIFICATION
 Crystal Mode — Parallel
 Frequency — 1 MHz \pm 0.1%
 $R_S = 540 \Omega$ typ
 $C_0 = 7$ pF typ
 Temperature Range — -40°C to $+85^\circ\text{C}$
 Test Level — 1 mW
 Suggested Crystal Suppliers
 Tyco, CTS Knight and
 Motorola Crystal Products

$R_F = 15 \text{ m}\Omega \pm 20\%$

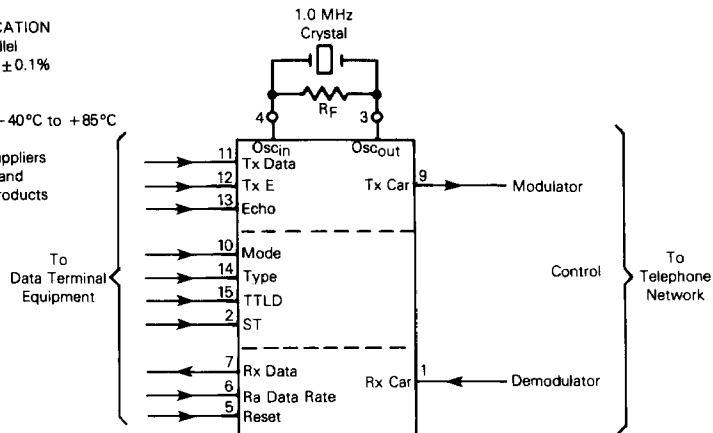

TRANSMIT CARRIER (Tx Car, Pin 9)

The Transmit Carrier is a digital-synthesized sine wave derived from a 1.0 MHz oscillator reference. The Tx CAR has an AC output impedance of 5 kΩ typical. The frequency characteristics are as follows:

United States Standard
Type = "1"
Echo = "0"

Mode		Tx Data	Tx Car
Originate	"1"	Mark "1"	1270 Hz
Originate	"1"	Space "0"	1070 Hz
Answer	"0"	Mark "1"	2225 Hz
Answer	"0"	Space "0"	2025 Hz

C.C.I.T.T. Standard
Type = "0"
Echo = "0"

Mode		Tx Data	Tx Car
Channel No. 1	"1"	Mark "1"	980 Hz
Channel No. 1	"1"	Space "0"	1180 Hz
Channel No. 2	"0"	Mark "1"	1650 Hz
Channel No. 2	"0"	Space "0"	1850 Hz

Echo Suppressor Disable Tone
Type = "0"
Echo = "1"

Mode	Tx Data	Tx Car
Chan. No. 2 "0"	"1"	2100 Hz

TRANSMIT ENABLE (Tx Enable, Pin 12)

The Transmit Carrier output is enabled when the Tx Enable input = "1". No output tone can be transmitted when Tx Enable = "0".

MODE (Pin 10)

The Mode input selects the pair of transmitting and receive frequencies used during modulation and demodulation. When Mode = "1", the U.S. originate mode is selected (Type input = "1") or the C.C.I.T.T. Channel No. 1 (Type input = "0"). When mode = "0", the U.S. answer mode is selected (Type input = "1") or the C.C.I.T.T. Channel No. 2 (Type input = "0").

ECHO (Pin 13)

When the Echo input = "1" (Type = "0", Mode = "0", Tx Data = "1") the modulator will transmit a 2100 Hz tone for

disabling line echo suppressors. During normal data transmission, this input should be low = "0".

RECEIVE DATA (Rx Data, Pin 7)

The Receive Data output is the digital data resulting from demodulating the Receive Carrier.

RECEIVE CARRIER (Rx Car, Pin 1)

The Receive Carrier is the FSK input to the demodulator. This input must have either a CMOS or TTL compatible logic level input (see TTL pull-up disable) at a duty cycle of 50% ± 2%, that is a square wave resulting from a signal limiter.

RECEIVE DATA RATE (Rx Rate, Pin 6)

The demodulator has been optimized for signal to noise performance at 300, and 600 bps.

Data Rate	Rx Rate
0-300 bps	"1"
0-600 bps	"0"

SELF TEST (ST, Pin 2)

When a high level (ST = "1") is placed on this input, the demodulator is switched to the modulator frequency and demodulates the transmitted FSK signal.

RESET (Pin 5)

This input is provided to decrease the test time of the chip. In normal operation, this input may be used to disable the demodulator (Reset = "1") — otherwise it should be tied low = "0". The reset pin does not reset Rx data pin 7.

CRYSTAL (Osc_{in}, Osc_{out}, Pin 4, Pin 3, respectively)

A 1.0 MHz crystal is required to utilize the on chip oscillator. A 1.0 MHz square wave clock can also be applied to the Osc_{in} input to satisfy the clock requirement (see Figure 2).

When utilizing the 1.0 MHz crystal, external parasitic capacitance, including crystal shunt capacitance, must be < 9 pF at the crystal input (pin 4). Pin 3 is capable of driving only one CMOS input.

TTL PULL-UP DISABLE (TTLD, Pin 15)

To improve TTL interface compatibility, all of the inputs to the MODEM have controllable P-Channel devices which act as pull-up resistors when TTLD input is low ("0"). When the input is taken high ("1") the pull-up is disabled, thus reducing power dissipation when interfacing with CMOS. Pin 15 should be taken high ("1") with V_{DD} greater than 6 volts.

FIGURE 3 — M6800 MICROCOMPUTER FAMILY BLOCK DIAGRAM

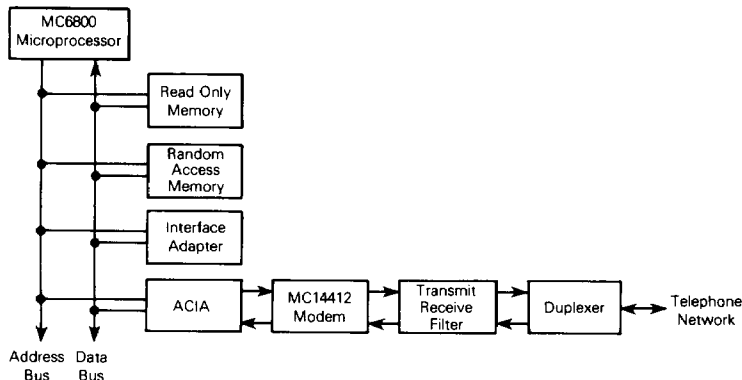

FIGURE 4 – TRANSMIT CARRIER SINEWAVE

$R_L = 100\text{ k}$ $V_{DD} = 5\text{ V}$ (TxCar)

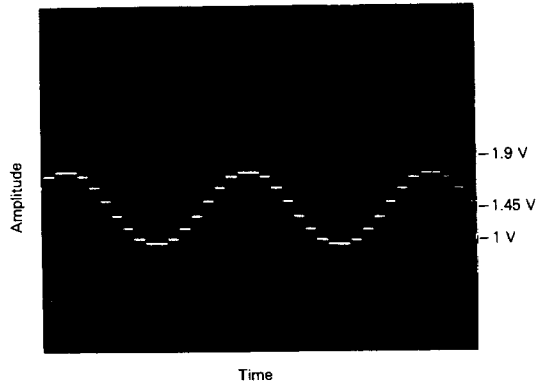

FIGURE 5 – TYPICAL TRANSMIT CARRIER FREQUENCY SPECTRUM

