

HD6303X, HD63A03X, HD63B03X CMOS MPU (Micro Processing Unit)

查询HD6303X供应商 找零件 专业PCB打样工厂, 24小时加急出货

The HD6303X is a CMOS 8-bit micro processing unit (MPU) which includes a CPU compatible with the HD6301V1, 192 bytes of RAM, 24 parallel I/O pins, a Serial Communication Interface (SCI) and two timers on chip.

FEATURES

- Instruction Set Compatible with the HD6301V1
- 192 Bytes of RAM
- 24 Parallel I/O Pins
 - 16 I/O Pins-Port 2, 6
 - 8 Input Pins-Port 5
- Darlington Transistor Drive (Port 2, 6)
- 16-Bit Programmable Timer
- Input Capture Register x 1
- Free Running Counter x 1
- Output Compare Register x 2
- 8-Bit Reloadable Timer
- External Event Counter Square Wave Generation
- Serial Communication Interface
- Memory Ready
- Halt
- Error-Detection (Address Trap, Op-Code Trap)
- Interrupts . . . 3 External, 7 Internal
- Up to 65k Bytes Address Space
- Low Power Dissipation Mode
 - Sleep Mode
 - Standby Mode
- Minimum Instruction Execution Time $\sim 0.5\mu\text{s}$ ($f = 2.0 \text{ MHz}$)
- Wide Range of Operation
 - $V_{CC} = 3 \sim 6V$ ($f = 0.1 \sim 0.5 \text{ MHz}$).
 - $V_{CC} = 5V \pm 10\%$
 - $f = 0.1 \sim 1.0 \text{ MHz}$; HD6303X
 - $f = 0.1 \sim 1.5 \text{ MHz}$; HD63A03X
 - $f = 0.1 \sim 2.0 \text{ MHz}$; HD63B03X

PROGRAM DEVELOPMENT SUPPORT TOOLS

- Cross assembler and C compiler software for IBM PCs and compatibles
- In circuit emulator for use with IBM PCs and compatibles

HD6303XP, HD63A03XP,
HD63B03XP



(DP-64S)

HD6303XF, HD63A03XF,
HD63B03XF



(FP-80)

HD6303XCP, HD63A03XCP,
HD63B03XCP

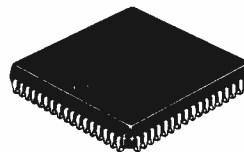

(CP-68)



HD6303X, HD63A03X, HD63B03X

● PIN ARRANGEMENT

● HD6303XP, HD63A03XP, HD63B03XP

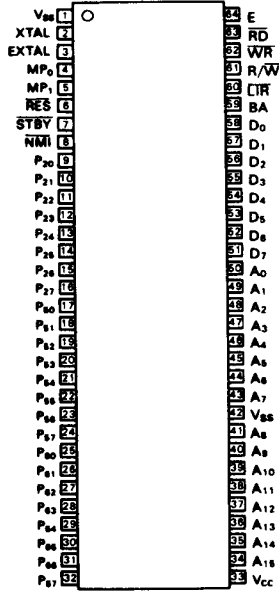

(Top View)

● HD6303XF, HD63A03XF, HD63B03XF

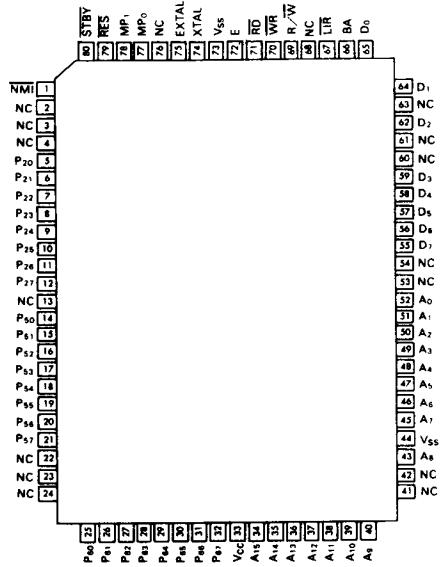

(Top View)

● HD6303XCP, HD63A03XCP, HD63B03XCP

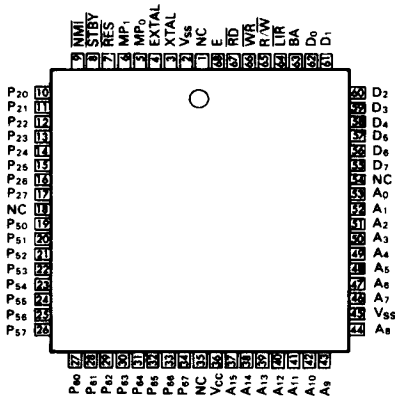

(Top View)



HD6303X, HD63A03X, HD63B03X

■ BLOCK DIAGRAM

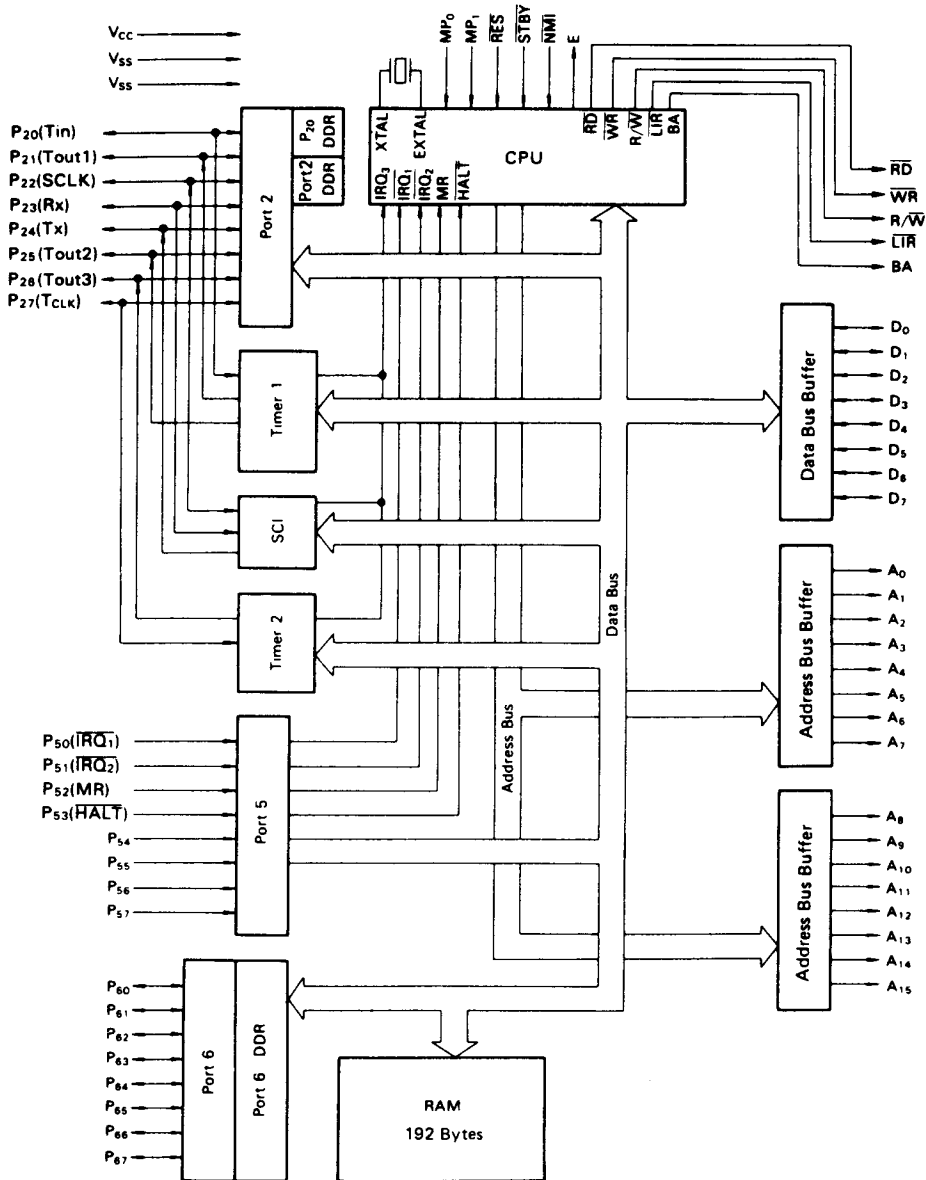

HD6303X, HD63A03X, HD63B03X

■ ABSOLUTE MAXIMUM RATINGS

Item	Symbol	Value	Unit
Supply Voltage	V_{CC}	-0.3 ~ +7.0	V
Input Voltage	V_{in}	-0.3 ~ $V_{CC}+0.3$	V
Operating Temperature	T_{opr}	0 ~ +70	°C
Storage Temperature	T_{stg}	-55 ~ +150	°C

(NOTE) This product has protection circuits in input terminal from high static electricity voltage and high electric field. But be careful not to apply overvoltage more than maximum ratings to these high input impedance protection circuits. To assure the normal operation, we recommend $V_{in}, V_{out}, V_{SS} \leq (V_{in} \text{ or } V_{out}) \leq V_{CC}$.

■ ELECTRICAL CHARACTERISTICS

- DC CHARACTERISTICS ($V_{CC} = 5.0V \pm 10\%$, $V_{SS} = 0V$, $T_a = 0 \sim +70^\circ C$, unless otherwise noted.)

Item	Symbol	Test Condition	min	typ	max	Unit	
Input "High" Voltage	RES, STBY		$V_{CC}-0.5$	—	$V_{CC}+0.3$	V	
	EXTAL		$V_{CC} \times 0.7$	—			
	Other Inputs		2.0	—			
Input "Low" Voltage	All Inputs	V_{IL}	-0.3	—	0.8	V	
Input Leakage Current	NMI, RES, STBY, MP ₀ , MP ₁ , Port 5	$ I_{in} $	$V_{in} = 0.5 \sim V_{CC}-0.5V$	—	—	1.0	μA
Three State (off-state) Leakage Current	A ₀ ~A ₁₅ , D ₀ ~D ₇ , RD, WR, R/W, Port 2, Port 6	$ I_{TSL} $	$V_{in} = 0.5 \sim V_{CC}-0.5V$	—	—	1.0	μA
Output "High" Voltage	All Outputs	V_{OH}	$I_{OH} = -200\mu A$	2.4	—	—	V
			$I_{OH} = -10\mu A$	$V_{CC}-0.7$	—	—	V
Output "Low" Voltage	All Outputs	V_{OL}	$I_{OL} = 1.6mA$	—	—	0.4	V
Darlington Drive Current	Ports 2, 6	$-I_{OH}$	$V_{out} = 1.5V$	1.0	—	10.0	mA
Input Capacitance	All Inputs	C_{in}	$V_{in} = 0V, f = 1MHz, T_a = 25^\circ C$	—	—	12.5	pF
Standby Current	Non Operation	I_{STB}		—	3.0	15.0	μA
Current Dissipation*	I_{SLP}		Sleeping (f = 1MHz**)	—	1.5	3.0	mA
			Sleeping (f = 1.5MHz**)	—	2.3	4.5	mA
			Sleeping (f = 2MHz**)	—	3.0	6.0	mA
	I_{CC}		Operating (f = 1MHz**)	—	7.0	10.0	mA
			Operating (f = 1.5MHz**)	—	10.5	15.0	mA
			Operating (f = 2MHz**)	—	14.0	20.0	mA
RAM Standby Voltage		V_{RAM}		2.0	—	—	V

* $V_{IH} \text{ min} = V_{CC} - 1.0V, V_{IL} \text{ max} = 0.8V$. All output terminals are at no load.

** Current Dissipation of the operating or sleeping condition is proportional to the operating frequency. So the typ. or max. values about Current Dissipations at x MHz operation are decided according to the following formula:

typ. value (f = x MHz) = typ. value (f = 1MHz) x x
 max. value (f = x MHz) = max. value (f = 1MHz) x x
 (both the sleeping and operating)

2



HD6303X, HD63A03X, HD63B03X

• AC CHARACTERISTICS ($V_{CC} = 5.0V \pm 10\%$, $V_{SS} = 0V$, $T_A = 0 \sim +70^\circ C$, unless otherwise noted.)

BUS TIMING

Item	Symbol	Test Condition	HD6303X			HD63A03X			HD63B03X			Unit
			min	typ	max	min	typ	max	min	typ	max	
Cycle Time	t_{CYC}	Fig. 1	1	--	10	0.666	--	10	0.5	--	10	μs
Enable Rise Time	t_{ER}		--	--	25	--	--	25	--	--	25	ns
Enable Fall Time	t_{EF}		--	--	25	--	--	25	--	--	25	ns
Enable Pulse Width "High" Level*	PW_{EH}		450	--	--	300	--	--	220	--	--	ns
Enable Pulse Width "Low" Level*	PW_{EL}		450	--	--	300	--	--	220	--	--	ns
Address, R/W Delay Time*	t_{AD}		--	--	250	--	--	190	--	--	160	ns
Data Delay Time	Write t_{DDW}		--	--	200	--	--	160	--	--	120	ns
Data Set-up Time	Read t_{DSR}		80	--	--	70	--	--	70	--	--	ns
Address, R/W Hold Time*	t_{AH}		80	--	--	50	--	--	35	--	--	ns
Data Hold Time	Write* t_{HW}		80	--	--	50	--	--	40	--	--	ns
	Read t_{HR}		0	--	--	0	--	--	0	--	--	ns
RD, WR Pulse Width*	PW_{RW}		450	--	--	300	--	--	220	--	--	ns
RD, WR Delay Time	t_{RWD}		--	--	40	--	--	40	--	--	40	ns
RD, WR Hold Time	t_{HRW}		--	--	30	--	--	30	--	--	25	ns
LIR Delay Time	t_{DLR}		--	--	200	--	--	160	--	--	120	ns
LIR Hold Time	t_{HLR}		10	--	--	10	--	--	10	--	--	ns
MR Set-up Time*	t_{SMR}		400	--	--	280	--	--	230	--	--	ns
MR Hold Time*	t_{HMR}		--	--	90	--	--	40	--	--	0	ns
E Clock Pulse Width at MR	PW_{EMR}		--	--	9	--	--	9	--	--	9	μs
Processor Control Set-up Time	t_{PCS}		Fig. 3, 10, 11	200	--	--	200	--	--	200	--	--
Processor Control Rise Time	t_{PCR}	Fig. 2, 3	--	--	100	--	--	100	--	--	100	ns
Processor Control Fall Time	t_{PCF}		--	--	100	--	--	100	--	--	100	ns
BA Delay Time	t_{BA}	Fig. 3	--	--	250	--	--	190	--	--	160	ns
Oscillator Stabilization Time	t_{AC}	Fig. 11	20	--	--	20	--	--	20	--	--	ms
Reset Pulse Width	PW_{RST}		3	--	--	3	--	--	3	--	--	t_{CYC}

* These timings change in approximate proportion to t_{CYC} . The figures in this characteristics represent those when t_{CYC} is minimum (= in the highest speed operation).

PERIPHERAL PORT TIMING

Item	Symbol	Test Condition	HD6303X			HD63A03X			HD63B03X			Unit
			min	typ	max	min	typ	max	min	typ	max	
Peripheral Data Set-up Time	Ports 2, 5, 6 t_{PDSU}	Fig. 5	200	--	--	200	--	--	200	--	--	ns
Peripheral Data Hold Time	Ports 2, 5, 6 t_{PDH}	Fig. 5	200	--	--	200	--	--	200	--	--	ns
Delay Time (Enable Negative Transition to Peripheral Data Valid)	Ports 2, 6 t_{PWD}	Fig. 6	--	--	300	--	--	300	--	--	300	ns



HD6303X, HD63A03X, HD63B03X

TIMER, SCI TIMING

Item	Symbol	Test Condition	HD6303X			HD63A03X			HD63B03X			Unit
			min	typ	max	min	typ	max	min	typ	max	
Timer 1 Input Pulse Width	t _{PWT}	Fig. 8	2.0	—	—	2.0	—	—	2.0	—	—	t _{eyc}
Delay Time (Enable Positive Transition to Timer Output)	t _{TOD}	Fig. 7	—	—	400	—	—	400	—	—	400	ns
SCI Input Clock Cycle	Async. Mode	Fig. 8	1.0	—	—	1.0	—	—	1.0	—	—	t _{eyc}
	Clock Sync.	Fig. 4, 8	2.0	—	—	2.0	—	—	2.0	—	—	t _{eyc}
SCI Transmit Data Delay Time (Clock Sync. Mode)	t _{TXD}	Fig. 4	—	—	200	—	—	200	—	—	200	ns
SCI Receive Data Set-up Time (Clock Sync. Mode)	t _{SRX}		290	—	—	290	—	—	290	—	—	ns
SCI Receive Data Hold Time (Clock Sync. Mode)	t _{HRX}		100	—	—	100	—	—	100	—	—	ns
SCI Input Clock Pulse Width	t _{PWSCK}	Fig. 8	0.4	—	0.6	0.4	—	0.6	0.4	—	0.6	t _{Scyc}
Timer 2 Input Clock Cycle	t _{tcyc}		2.0	—	—	2.0	—	—	2.0	—	—	t _{eyc}
Timer 2 Input Clock Pulse Width	t _{PWTCK}		200	—	—	200	—	—	200	—	—	ns
Timer 1-2, SCI Input Clock Rise Time	t _{CKr}		—	—	100	—	—	100	—	—	100	ns
Timer 1-2, SCI Input Clock Fall Time	t _{CKf}		—	—	100	—	—	100	—	—	100	ns



HD6303X, HD63A03X, HD63B03X

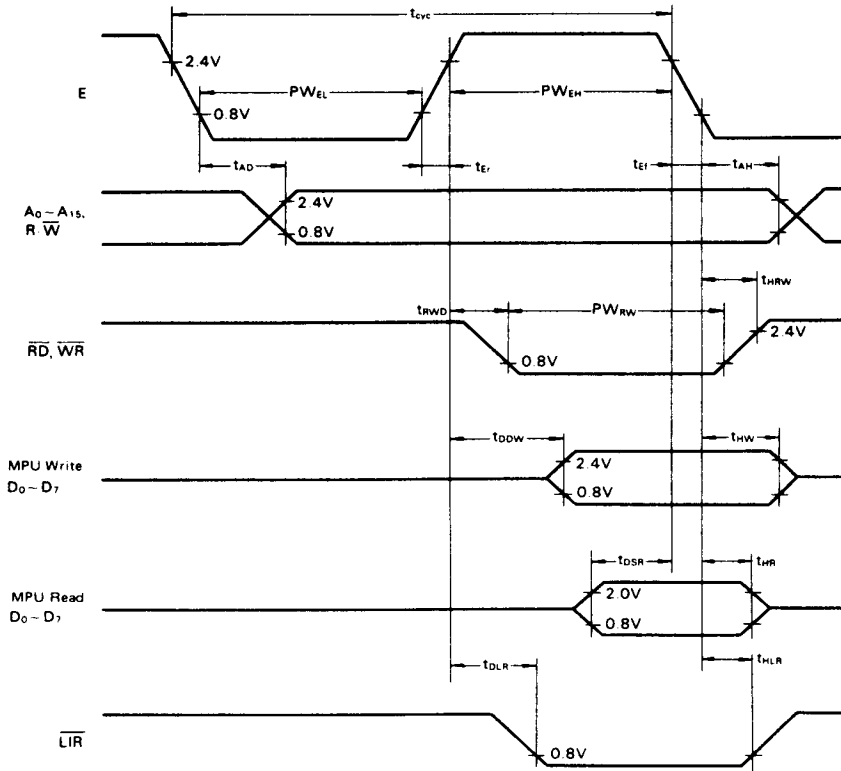

Figure 1 Bus Timing

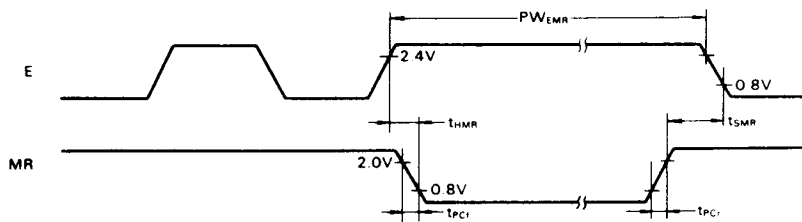

Figure 2 Memory Ready and E Clock Timing



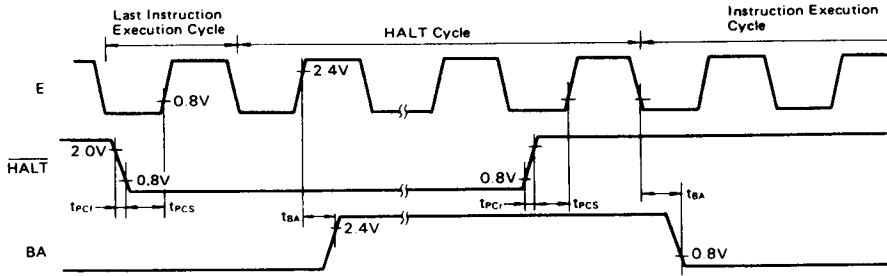

Figure 3 HALT and BA Timing

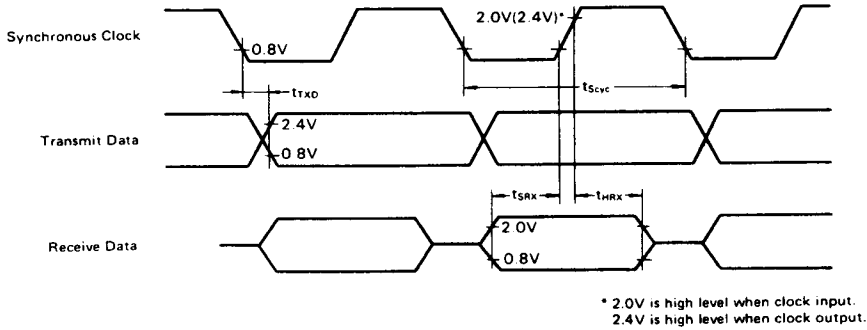

Figure 4 SCI Clocked Synchronous Timing

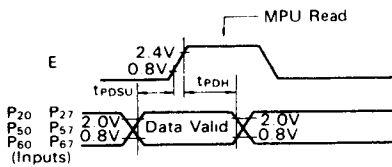

Figure 5 Port Data Set-up and Hold Times (MPU Read)

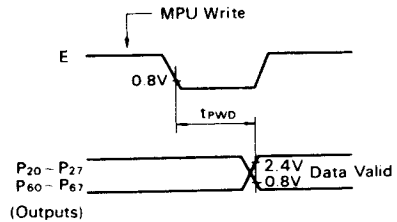
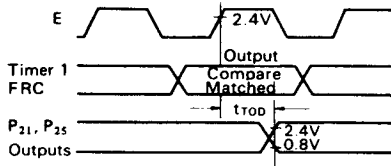
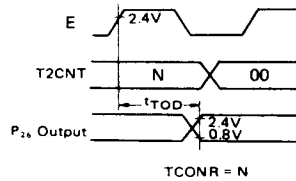

Figure 6 Port Data Delay Times (MPU Write)

HD6303X, HD63A03X, HD63B03X



(a) Timer 1 Output Timing



(b) Timer 2 Output Timing

Figure 7 Timer Output Timing

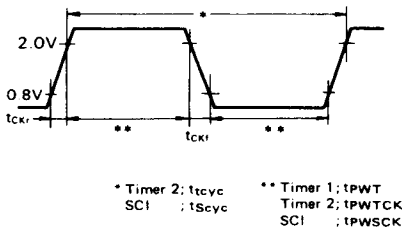
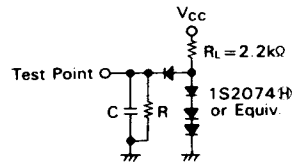

Figure 8 Timer 1-2, SCI Input Clock Timing



C = 90pF for D₀~D₇, A₀~A₁₅, E
 = 30pF for Port 2, Port 6, RD, WR, R/W, BA, LIR
 R = 12kΩ

Figure 9 Bus Timing Test Loads (TTL Load)

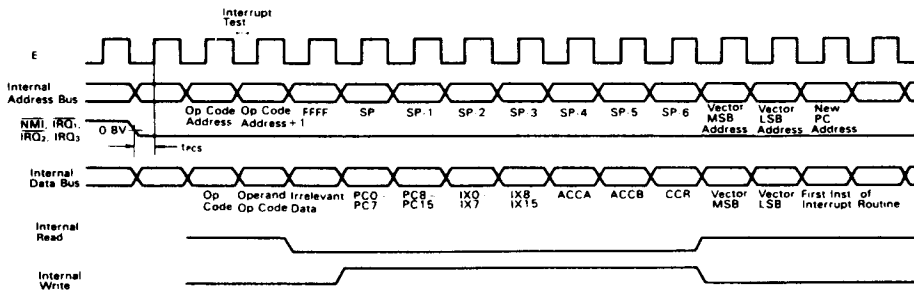

Figure 10 Interrupt Sequence



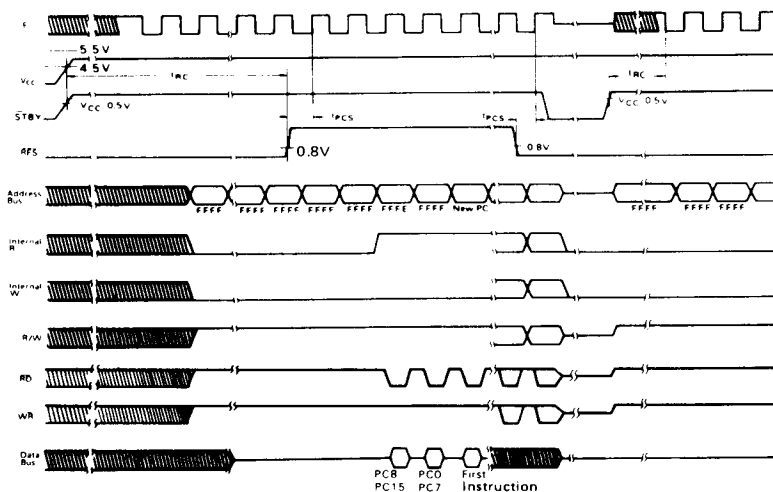

Figure 11 Reset Timing

● **FUNCTIONAL PIN DESCRIPTION**

● **V_{CC}, V_{SS}**

V_{CC} and V_{SS} provide power to the MPU with 5V±10% supply. In the case of low speed operation (f_{max} = 500kHz), the MPU can operate with three through six volts. Two V_{SS} pins should be tied to ground.

● **XTAL, EXTAL**

These two pins interface with an AT-cut parallel resonant crystal. Divide-by-four circuit is on chip, so if 4MHz crystal oscillator is used, the system clock is 1MHz for example.

AT Cut Parallel Resonant Crystal Oscillator

C₀ = 7pF max
R_s = 60Ω max

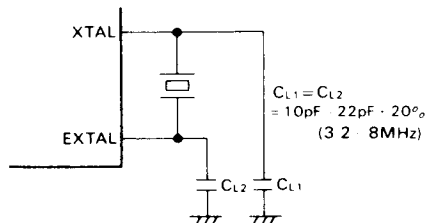

Figure 12 Crystal Interface

EXTAL pin can be driven by the external clock of 45 to 55% duty, and one fourth frequency of the external clock is produced in the LSI. The external clock frequency should be less than four times of the maximum operable frequency. When using the external clock, XTAL pin should be open. Fig. 12 shows an example of the crystal interface. The crystal and C_{L1}, C_{L2} should be mounted as close as possible to XTAL

and EXTAL pins. Any line must not cross the line between the crystal oscillator and XTAL. EXTAL.

● **STBY**

This pin makes the MPU standby mode. In "Low" level, the oscillation stops and the internal clock is stabilized to make reset condition. To retain the contents of RAM at standby mode, "0" should be written into RAM enable bit (RAME). RAME is the bit 6 of the RAM/port 5 control register at \$0014. RAM is disabled by this operation and its contents is sustained.

Refer to "LOW POWER DISSIPATION MODE" for the standby mode.

● **Reset (RES)**

This pin resets the MPU from power OFF state and provides a startup procedure. During power-on, RES pin must be held "Low" level for at least 20ms.

The CPU registers (accumulator, index register, stack pointer, condition code register except for interrupt mask bit), RAM and the data register of a port are not initialized during reset, so their contents are unknown in this procedure.

To reset the MPU during operation, RES should be held "Low" for at least 3 system-clock cycles. At the 3rd cycle during "Low" level, all the address buses become "High". When RES remains "Low", the address buses keep "High". If RES becomes "High", the MPU starts the next operation.

- (1) Latch the value of the mode program pins; MP₀ and MP₁.
- (2) Initialize each internal register (Refer to Table 3).
- (3) Set the interrupt mask bit. For the CPU to recognize the maskable interrupts IRQ₁, IRQ₂ and IRQ₃, this bit should be cleared in advance.
- (4) Put the contents (= start address) of the last two addresses (SFFF, SFFF) into the program counter and start the program from this address. (Refer to Table 1).

*The MPU is usable to accept a reset input until the clock



HD6303X, HD63A03X, HD63B03X

becomes normal oscillation after power on (max. 20ms). During this transient time, the MPU and I/O pins are undefined. Please be aware of this for system designing.

- **Enable (E)**

This pin provides a TTL-compatible system clock to external circuits. Its frequency is one fourth that of the crystal oscillator or external clock. This pin can drive one TTL load and 90pF capacitance.

- **Non-Maskable Interrupt ($\overline{\text{NMI}}$)**

When the falling edge of the input signal is detected at this pin, the CPU begins non-maskable interrupt sequence internally. As well as the IRQ mentioned below, the instruction being executed at $\overline{\text{NMI}}$ signal detection will proceed to its completion. The interrupt mask bit of the condition code register doesn't affect non-maskable interrupt at all.

When starting the acknowledge to the $\overline{\text{NMI}}$, the contents of the program counter, index register, accumulators and condition code register will be saved onto the stack. Upon completion of this sequence, a vector is fetched from \$FFFC and \$FFFD to transfer their contents into the program counter and branch to the non-maskable interrupt service routine.

(Note) After reset start, the stack pointer should be initialized on an appropriate memory area and then the falling edge

should be input to $\overline{\text{NMI}}$ pin.

- **Interrupt Request ($\overline{\text{IRQ}}_1$, $\overline{\text{IRQ}}_2$)**

These are level-sensitive pins which request an internal interrupt sequence to the CPU. At interrupt request, the CPU will complete the current instruction before its request acknowledgement. Unless the interrupt mask in the condition code register is set, the CPU starts an interrupt sequence; if set, the interrupt request will be ignored. When the sequence starts, the contents of the program counter, index register, accumulators and condition code register will be saved onto the stack, then the CPU sets the interrupt mask bit and will not acknowledge the maskable request. During the last cycle, the CPU fetches vectors depicted in Table 1 and transfers their contents to the program counter and branches to the service routine.

The CPU uses the external interrupt pins, $\overline{\text{IRQ}}_1$ and $\overline{\text{IRQ}}_2$, also as port pins P₅₀ and P₅₁, so it provides an enable bit to Bit 0 and 1 of the RAM port 5 control register at \$0014. Refer to "RAM/PORT 5 CONTROL REGISTER" for the details.

When one of the internal interrupts, ICI, OCI, TOI, CMI or SIO is generated, the CPU produces internal interrupt signal (IRQ₃). IRQ₃ functions just the same as $\overline{\text{IRQ}}_1$ or $\overline{\text{IRQ}}_2$ except for its vector address. Fig. 13 shows the block diagram of the interrupt circuit.

Table 1 Interrupt Vector Memory Map

Priority	Vector		Interrupt
	MSB	LSB	
Highest ↑ ↓ Lowest	FFFE	FFFF	$\overline{\text{RES}}$
	FFEE	FFEF	TRAP
	FFFC	FFFD	$\overline{\text{NMI}}$
	FFFA	FFFB	SWI (Software Interrupt)
	FFF8	FFF9	$\overline{\text{IRQ}}_1$
	FFF6	FFF7	ICI (Timer 1 Input Capture)
	FFF4	FFF5	OCI (Timer 1 Output Compare 1, 2)
	FFF2	FFF3	TOI (Timer 1 Overflow)
	FFEC	FFED	CMI (Timer 2 Counter Match)
	FFEA	FFEB	$\overline{\text{IRQ}}_2$
	FFF0	FFF1	SIO (RDRF+ORFE+TDRE)



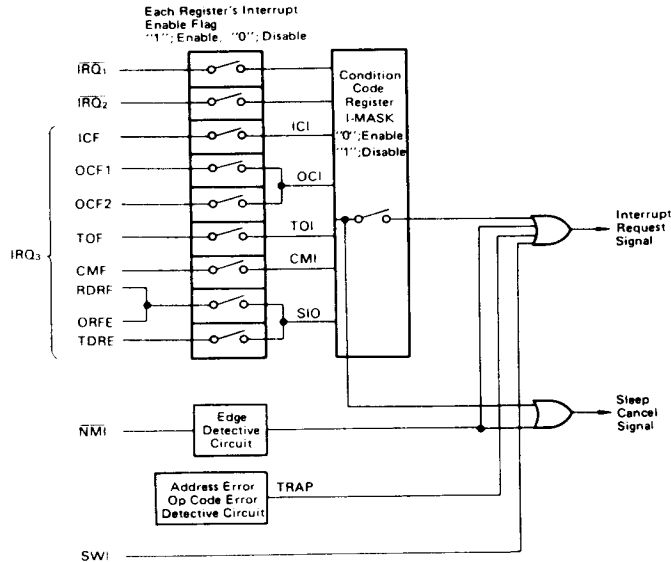

Figure 13 Interrupt Circuit Block Diagram

2

• **Mode Program (MP₀, MP₁)**

To operate MPU, MP₀ pin should be connected to "High" level and MP₁ should be connected to "Low" level (refer to Fig. 15).

• **Read/Write (R/W)**

This signal, usually be in read state ("High"), shows whether the CPU is in read ("High") or write ("Low") state to the peripheral or memory devices. This can drive one TTL load and 30pF capacitance.

• **RD, WR**

These signals show active low outputs when the CPU is reading/writing to the peripherals or memories. This enables the CPU easy to access the peripheral LSI with RD and WR input pins. These pins can drive one TTL load and 30pF capacitance.

• **Load Instruction Register (LIR)**

This signal shows the instruction opcode being on data bus (active low). This pin can drive one TTL load and 30pF capacitance.

• **Memory Ready (MR; P₅₂)**

This is the input control signal which stretches the system clock's "High" period to access low-speed memories. During this signal is in "High", the system clock operates in normal sequence. But this signal in "Low", the "High" period of the system clock will be stretched depending on its "Low" level duration in integral multiples of the cycle time. This allows the CPU to interface with low-speed memories (see Fig. 2). Up to 9 μs can be stretched.

During internal address space access or nonvalid memory

access, MR is prohibited internally to prevent decrease of operation speed. Even in the halt state, MR can also stretch "High" period of system clock to allow peripheral devices to access low-speed memories. As this signal is used also as P₅₂, an enable bit is provided at bit 2 of the RAM/port 5 control register at \$0014. Refer to "RAM/PORT 5 CONTROL REGISTER" for more details.

• **Halt (HALT; P₅₃)**

This is an input control signal to stop instruction execution and to release buses. When this signal switches to "Low", the CPU stops to enter into the halt state after having executed the present instruction. When entering into the halt state, it makes BA (P₇₄) "High" and also an address bus, data bus, RD, WR, R/W high impedance. When an interrupt is generated in the halt state, the CPU uses the interrupt handler after the halt is cancelled.

(Note) 1 Please don't switch the HALT signal to "Low" when the CPU executes the WAI instruction and is in the interrupt wait state to avoid the trouble of the CPU's operation after the halt is cancelled.

2. When power is supplied with the condition that HALT is "low", MCU cannot sometimes release the reset condition, even if RESET becomes "High". HALT should be low before RESET rises up.

• **Bus Available (BA)**

This is an output control signal which is normally "Low" but "High" when the CPU accepts HALT and releases the buses. The HD6800 and HD6802 make BA "High" and release the buses at WAI execution, while the HD6303X doesn't make BA "High" under the same condition. But if the HALT becomes



HD6303X, HD63A03X, HD63B03X

"Low" when the CPU is in the interrupt wait state after having executed the WAI, the CPU makes BA "High" and releases the buses. And when the HALT becomes "High", the CPU returns to the interrupt wait state.

■ PORT

The HD6303X provides three I/O ports. Table 2 gives the address of ports and the data direction register and Fig. 14 the block diagrams of each port.

Table 2 Port and Data Direction Register Address

Port	Port Address	Data Direction Register
Port 2	\$0003	\$0001
Port 5	\$0015	—
Port 6	\$0017	\$0016

● Port 2

An 8-bit input/output port. The data direction register (DDR) of port 2 controls the I/O state. It provides two bits;

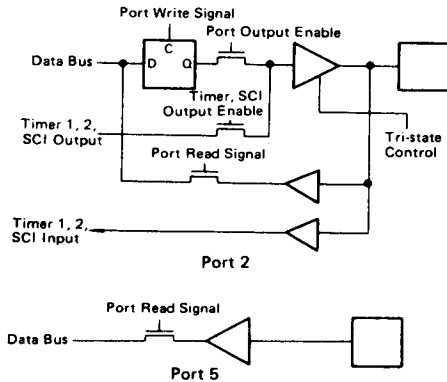

Figure 14 Port Block Diagram

● Port 5

An 8-bit port for input only. The lower four bits are also usable as input pins for interrupt, MR and HALT.

● Port 6

An 8-bit I/O port. This port provides an 8-bit DDR corresponding to each bit and can specify input or output by the bit ("0" for input, "1" for output). This port can drive one TTL load and 30pF capacitance. A reset clears the DDR of port 6. In addition, it can produce 1mA current when $V_{out} = 1.5V$ to drive directly the base of Darlington transistors.

■ BUS

● $D_0 \sim D_7$

These pins are data bus and can drive one TTL load and 90pF capacitance respectively.

● $A_0 \sim A_{15}$

These pins are address bus and can drive one TTL load and 90pF capacitance respectively.

bit 0 decides the I/O direction of P_{20} and bit 1 the I/O direction of P_{21} to P_{27} ("0" for input, "1" for output).

Port 2 is also used as an I/O pin for the timers and the SCI. When used as an I/O pin for the timers and the SCI, port 2 except P_{20} automatically becomes an input or an output depending on their functions regardless of the data direction register's value.

Port 2 Data Direction Register

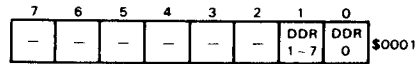

A reset clears the DDR of port 2 and configures port 2 as an input port. This port can drive one TTL and 30pF capacitance. In addition, it can produce 1mA current when $V_{out} = 1.5V$ to drive directly the base of Darlington transistors.

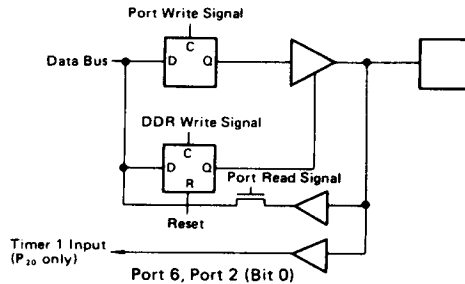

■ RAM/PORT 5 CONTROL REGISTER

The control register located at \$0014 controls on-chip RAM and port 5.

RAM/Port 5 Control Register

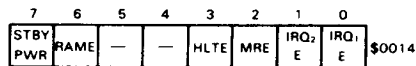

Bit 0, Bit 1 $\overline{IRQ_1}$, $\overline{IRQ_2}$ Enable Bit (IRQ₁E, IRQ₂E)

When using P_{50} and P_{51} as interrupt pins, write "1" in these bits. When "0", the CPU doesn't accept an external interrupt or a sleep cancellation by the external interrupt. These bits become "0" during reset.

Bit 2 Memory Ready Enable Bit (MRE)

When using P_{52} as an input for Memory Ready signal, write "1" in this bit. When "0", the memory ready function is pro-

HD6303X, HD63A03X, HD63B03X

hibited and P_{52} can be used as I/O port. This bit becomes "1" during reset.

Bit 3 Halt Enable bit (HLTE)

When using P_{53} as an input for Halt signal, write "1" in this bit. When "0", the halt function is prohibited and P_{53} can be used as I/O port. This bit becomes "1" during reset.

(Note) When using P_{52} and P_{53} as the input ports in mode 1 and 2, MRE and HLTE bit should be cleared just after the reset.

Notice that memory ready and halt function is enable till MRE and HLTE bit is cleared.

Bit 4, Bit 5 Not Used.

Bit 6 RAM Enable (RAME)

On-chip RAM can be disabled by this control bit. By resetting the MPU, "1" is set to this bit, and on-chip RAM is enabled. This bit can be written "1" or "0" by software. When RAM is in disable condition (= logic "0"), on-chip RAM is invalid and the CPU can read data from external memory. This bit should be "0" before getting into the standby mode to protect on-chip RAM data.

Bit 7 Standby Power Bit (STBY PWR)

When V_{CC} is not provided in standby mode, this bit is cleared. This is a flag for both read/write by software. If this bit is set before standby mode, and remains set even after returning from standby mode, V_{CC} voltage is provided during standby

mode and the on-chip RAM data is valid.

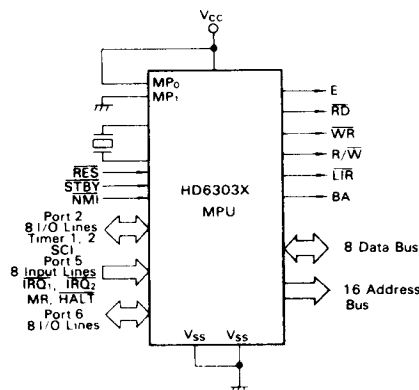

Figure 15 Operation Mode

■ MEMORY MAP

The MPU can address up to 65k bytes. Fig. 16 gives memory map of HD6303X. 32 internal registers use addresses from "00" as shown in Table 3.

Table 3 Internal Register

Address	Registers	R/W***	Initialize at RESET
00	-	-	-
01	Port 2 Data Direction Register	W	\$FC
02*	-	-	-
03	Port 2	R/W	Undefined
04*	-	-	-
05	-	-	-
06*	-	-	-
07*	-	-	-
08	Timer Control/Status Register 1	R/W	\$00
09	Free Running Counter ("High")	R/W	\$00
0A	Free Running Counter ("Low")	R/W	\$00
0B	Output Compare Register 1 ("High")	R/W	\$FF
0C	Output Compare Register 1 ("Low")	R/W	\$FF
0D	Input Capture Register ("High")	R	\$00
0E	Input Capture Register ("Low")	R	\$00
0F	Timer Control/Status Register 2	R/W	\$10
10	Rate, Mode Control Register	R/W	\$00
11	Tx/Rx Control Status Register	R/W	\$20
12	Receive Data Register	R	\$00
13	Transmit Data Register	W	\$00
14	RAM/Port 5 Control Register	R/W	\$7C or \$FC
15	Port 5	R	-
16	Port 6 Data Direction Register	W	\$00

(continued)

HD6303X, HD63A03X, HD63B03X

Table 3 Internal Register

Address	Registers	R/W***	Initialize at RESET
17	Port 6	R/W	Undefined
18*	—	—	—
19	Output Compare Register 2 ("High")	R/W	\$FF
1A	Output Compare Register 2 ("Low")	R/W	\$FF
1B	Timer Control/Status Register 3	R/W	\$20
1C	Time Constant Register	W	\$FF
1D	Timer 2 Up Counter	R/W	\$00
1E	—	—	—
1F**	Test Register	—	—

* External Address.
 ** Test Register. Do not access to this register.
 *** R : Read Only Register
 W : Write Only Register
 R/W : Read/Write Register

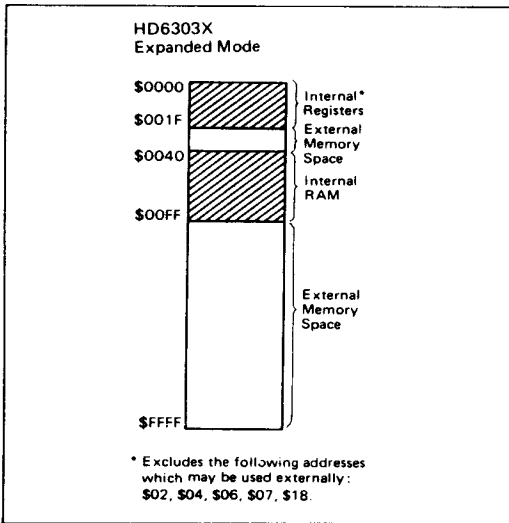

Figure 16 HD6303X Memory Map

■ TIMER 1

The HD6303X provides a 16-bit programmable timer which can simultaneously measure an input waveform and generate two independent output waveforms. The pulse widths of both input/output waveforms vary from microseconds to seconds.

Timer 1 is configured as follows (refer to Fig. 18).

- Control/Status Register 1 (8 bit)
 - Control/Status Register 2 (7 bit)
 - Free Running Counter (16 bit)
 - Output Compare Register 1 (16 bit)
 - Output Compare Register 2 (16 bit)
 - Input Capture Register (16 bit)
- **Free-Running Counter (FRC) (\$0009 : 000A)**
 The key timer element is a 16-bit free-running counter driven

and incremented by system clock. The counter value is readable by software without affecting the counter. The counter is cleared by reset.

When writing to the upper byte (\$09), the CPU writes the preset value (\$FFF8) into the counter (address \$09, \$0A) regardless of the write data value. But when writing to the lower byte (\$0A) after the upper byte writing, the CPU writes not only the lower byte data into lower 8 bit, but also the upper byte data into higher 8 bit of the FRC.

The counter will be as follows when the CPU writes to it by double store instructions (STD, STX etc.).

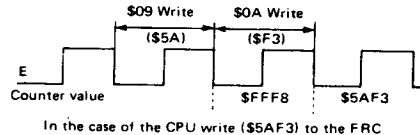

Figure 17 Counter Write Timing

● Output Compare Register (OCR) (\$000B, \$000C; OCR1) (\$0019, \$001A; OCR2)

The output compare register is a 16-bit read/write register which can control an output waveform. The data of OCR is always compared with the FRC.

When the data matches, output compare flag (OCF) in the timer control/status register (TCSR) is set. If an output enable bit (OE) in the TCSR2 is "1", an output level bit (OLVL) in the TCSR will be output to bit 1 (Tout 1) and bit 5 (Tout 2) of port 2. To control the output level again by the next compare, the value of OCR and OLVL should be changed. The OCR is set to \$FFFF at reset. The compare function is inhibited for a cycle just after a write to the OCR or to the upper byte of the FRC. This is to begin the comparison after setting the 16-bit value valid in the register and to inhibit the compare function at this cycle, because the CPU writes the upper byte to the FRC, and at the next cycle the counter is set to \$FFF8.

* For data write to the FRC or the OCR, 2-byte transfer instruction (such as STX etc.) should be used.

● Input Capture Register (ICR) (\$000D : 000E)

The input capture register is a 16-bit read only register which stores the FRC's value when external input signal transition



generates an input capture pulse. Such transition is controlled by input edge bit (IEDG) in the TCSR1.

In order to input the external input signal to the edge detector, a bit of the DDR corresponding to bit 0 of port 2 should be cleared ("0"). When an input capture pulse occurs by the external input signal transition at the next cycle of CPU's high-byte read of the ICR, the input capture pulse will be delayed by one cycle. In order to ensure the input capture operation, a CPU read of the ICR needs 2-byte transfer instruction. The input pulse width should be at least 2 system cycles. This register is cleared (\$0000) during reset.

● **Timer Control/Status Register 1 (TCSR1) (\$0008)**

The timer control/status register 1 is an 8-bit register. All bits are readable and the lower 5 bits are also writable. The upper 3 bits are read only which indicate the following timer status.

- Bit 5 The counter value reached to \$0000 as a result of counting-up (TOF).
- Bit 6 A match has occurred between the FRC and the OCR 1 (OCF1).
- Bit 7 Defined transition of the timer input signal causes the counter to transfer its data to the ICR (ICF).

The followings are each bit descriptions.

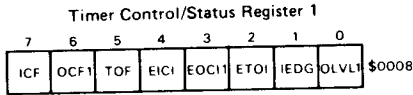

- Bit 0 **OLVL1 Output Level 1**
OLVL1 is transferred to port 2, bit 1 when a match occurs between the counter and the OCR1. If bit 0 of the TCSR2 (OE1) is set to "1", OLVL1 will appear at bit 1 of port 2.
- Bit 1 **IEDG Input Edge**
This bit determines which edge, rising or falling, of input signal of port 2, bit 0 will trigger data transfer from the counter to the ICR. For this function, the DDR corresponding to port 2, bit 0 should be cleared beforehand.
IEDG=0, triggered on a falling edge ("High" to "Low")
IEDG=1, triggered on a rising edge ("Low" to "High")
- Bit 2 **ETOI Enable Timer Overflow Interrupt**
When this bit is set, an internal interrupt (IRQ₃) by TOI interrupt is enabled. When cleared, the interrupt is inhibited.
- Bit 3 **EOC11 Enable Output Compare Interrupt 1**
When this bit is set, an internal interrupt (IRQ₃) by OC11 interrupt is enabled. When cleared, the interrupt is inhibited.
- Bit 4 **EIC1 Enable Input Capture Interrupt**
When this bit is set, an internal interrupt (IRQ₃) by IC1 interrupt is enabled. When cleared, the interrupt is inhibited.
- Bit 5 **TOF Timer Overflow Flag**
This read-only bit is set when the counter increments from \$FFFF by 1. Cleared when the counter's upper byte (\$0009) is ready by the CPU after the TCSR1 read.
- Bit 6 **OCF1 Output Compare Flag 1**
This read-only bit is set when a match occurs between the OCR1 and the FRC. Cleared when writing

to the OCR1 (\$000B or \$000C) after the TCSR1 or TCSR2 read.

Bit 7 **ICF Input Capture Flag**

This read-only bit is set when an input signal of port 2, bit 0 makes a transition as defined by IEDG and the FRC is transferred to the ICR. Cleared when reading the upper byte (\$000D) of the ICR following the TCSR1 or TCSR2 read.

● **Timer Control/Status Register 2 (TCSR2) (\$000F)**

The timer control/status register 2 is a 7-bit register. All bits are readable and the lower 4 bits are also writable. But the upper 3 bits are read-only which indicate the following timer status.

- Bit 5 A match has occurred between the FRC and the OCR2 (OCF2).
- Bit 6 The same status flag as the OCF1 flag of the TCSR1, bit 6.
- Bit 7 The same status flag as the ICF flag of the TCSR1, bit 7. The followings are the each bit descriptions.

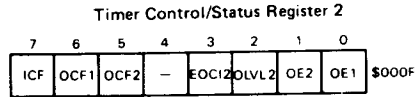

- Bit 0 **OE1 Output Enable 1**
This bit enables the OLVL1 to appear at port 2, bit 1 when a match has occurred between the counter and the output compare register 1. When this bit is cleared, bit 1 of port 2 will be an I/O port. When set, it will be an output of OLVL1 automatically.
- Bit 1 **OE2 Output Enable 2**
This bit enables the OLVL2 to appear at port 2, bit 5 when a match has occurred between the counter and the output compare register 2. When this bit is cleared, port 2, bit 5 will be an I/O port. When set, it will be an output of OLVL2 automatically.
- Bit 2 **OLVL2 Output Level 2**
OLVL2 is transferred to port 2, bit 5 when a match has occurred between the counter and the OCR2. If bit 5 of the TCSR2 (OE2) is set to "1", OLVL2 will appear at port 2, bit 5.
- Bit 3 **EOC12 Enable Output Compare Interrupt 2**
When this bit is set, an internal interrupt (IRQ₃) by OC12 interrupt is enabled. When cleared, the interrupt is inhibited.
- Bit 4 **Not Used**
- Bit 5 **OCF2 Output Compare Flag 2**
This read-only bit is set when a match has occurred between the counter and the OCR2. Cleared when writing to the OCR2 (\$0019 or \$001A) after the TCSR2 read.
- Bit 6 **OCF1 Output Compare Flag 1**
- Bit 7 **ICF Input Capture Flag**
OCF1 and ICF addresses are partially decoded. The CPU read of the TCSR1/TCSR2 makes it possible to read OCF1 and ICF into bit 6 and bit 7.
Both the TCSR1 and TCSR2 will be cleared during reset.
(Note) If OE1 or OE2 is set to "1" before the first output compare match occurs after reset restart, bit 1 or bit 5 of port 2 will produce "0" respectively.

HD6303X, HD63A03X, HD63B03X

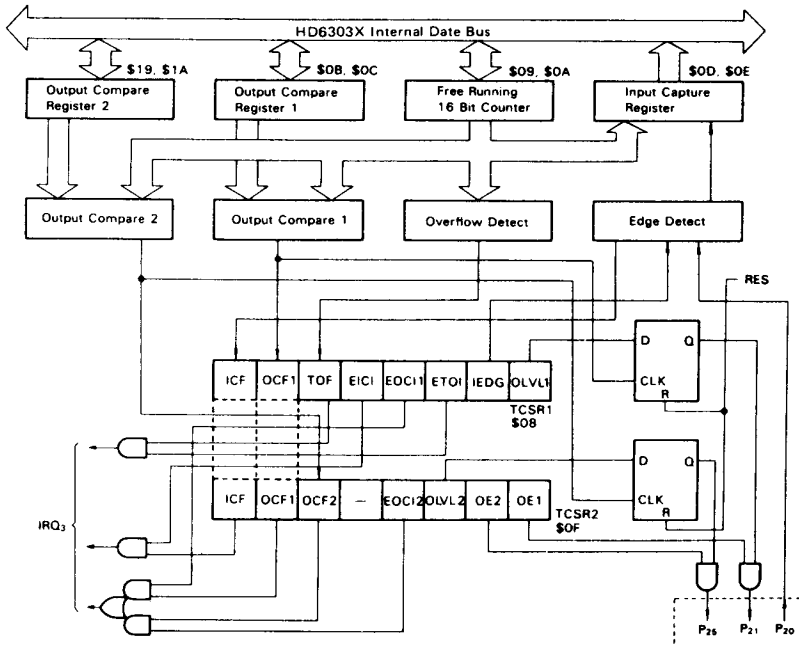

Figure 18 Timer 1 Block Diagram

■ TIMER 2

In addition to the timer 1, the HD6303X provides an 8-bit reloadable timer, which is capable of counting the external event. This timer 2 contains a timer output, so the MPU can generate three independent waveforms (refer to Fig. 19).

The timer 2 is configured as follows:

- Control/Status Register 3 (7 bit)
- 8-bit Up Counter
- Time Constant Register (8 bit)

● Timer 2 Up Counter (T2CNT) (\$001D)

This is an 8-bit up counter which operates with the clock decided by CKS0 and CKS1 of the TCSR3. The CPU can read the value of the counter without affecting the counter. In addition, any value can be written to the counter by software even during counting.

The counter is cleared when a match occurs between the counter and the TCONR or during reset.

If a write operation is made by software to the counter at the cycle of counter clear, it does not reset the counter but put the write data to the counter.

● Time Constant Register (TCONR) (\$001C)

The time constant register is an 8-bit write only register. It is always compared with the counter.

When a match has occurred, counter match flag (CMF) of the timer control status register 3 (TCSR3) is set and the value selected by TOS0 and TOS1 of the TCSR3 will appear at port 2, bit 6. When CMF is set, the counter will be cleared simultaneously and then start counting from \$00. This enables regular interrupts and waveform outputs without any software support. The TCONR is set to "\$FF" during reset.

● Timer Control/Status Register 3 (TCSR3) (\$001B)

The timer control/status register 3 is a 7-bit register. All bits are readable and 6 bits except for CMF can be written.

The followings are each pin descriptions.

Timer Control/Status Register 3								
7	6	5	4	3	2	1	0	
CMF	EICM1	—	T2E	TOS1	TOS0	CKS1	CKS0	\$001B

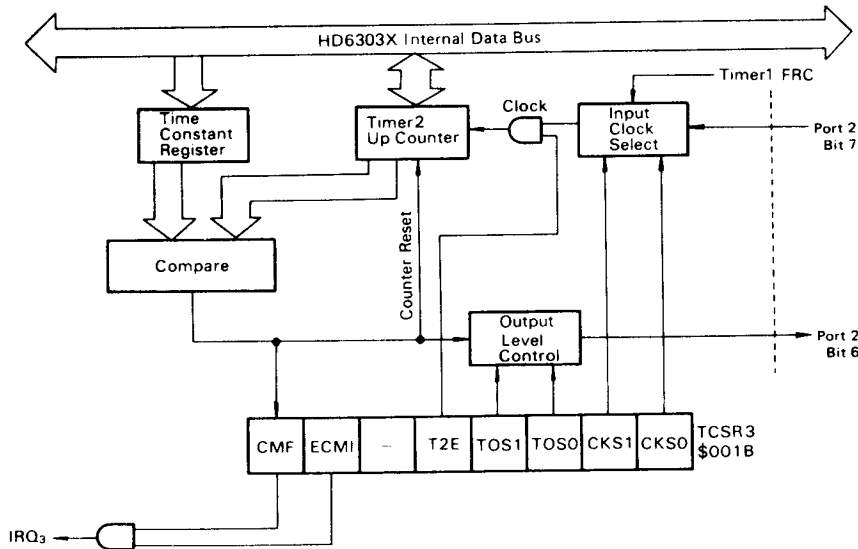

Figure 19 Timer 2 Block Diagram

2

- Bit 0 CKS0 Input Clock Select 0
- Bit 1 CKS1 Input Clock Select 1

Input clock to the counter is selected as shown in Table 4 depending on these two bits. When an external clock is selected, bit 7 of port 2 will be a clock input automatically. Timer 2 detects the rising edge of the external clock and increments the counter. The external clock is countable up to half the frequency of the system clock.

Table 4 Input Clock Select

CKS1	CKS0	Input Clock to the Counter
0	0	E clock
0	1	E clock/8*
1	0	E clock/128*
1	1	External clock

* These clocks come from the FRC of the timer 1. If one of these clocks is selected as an input clock to the up counter, the CPU should not write to the FRC of the timer 1.

- Bit 2 TOS0 Timer Output Select 0
- Bit 3 TOS1 Timer Output Select 1

When a match occurs between the counter and the TCONR timer 2 outputs shown in Table 5 will appear at port 2, bit 6 depending on these two bits. When both TOS0 and TOS1 are "0", bit 6 of port 2 will be an I/O port.

Table 5 Timer 2 Output Select

TOS1	TOS0	Timer Output
0	0	Timer Output Inhibited
0	1	Toggle Output*
1	0	Output "0"
1	1	Output "1"

* When a match occurs between the counter and the TCONR, timer 2 output level is reversed. This leads to production of a square wave with 50% duty to the external without any software support.

- Bit 4 T2E Timer 2 Enable Bit

When this bit is cleared, a clock input to the up counter is prohibited and the up counter stops. When set to "1", a clock selected by CKS1 and CKS0 (Table 4) is input to the up counter.

(Note) P₂₆ outputs "0" when T2E bit cleared and timer 2 set in output enable condition by TOS1 or TOS0. It also outputs "0" when T2E bit set "1" and timer 2 set in output enable condition before the first counter match occurs.

- Bit 5 Not Used
- Bit 6 ECMI Enable Counter Match Interrupt

When this bit is set, an internal interrupt (IRQ₃) by CMI is enabled. When cleared, the interrupt is inhibited.

- Bit 7 CMF Counter Match Flag

This read-only bit is set when a match occurs between the up counter and the TCONR. Cleared by writing "0" by software write (unable to write "1" by software).

Each bit of the TCSR3 is cleared during reset.

HD6303X, HD63A03X, HD63B03X

■ SERIAL COMMUNICATION INTERFACE (SCI)

The HD6303X SCI contains two operation modes; one is an asynchronous mode by the NRZ format and the other is a clocked synchronous mode which transfers data synchronizing with the serial clock.

The SCI consists of the following registers as shown in Fig. 20 Block Diagram:

- Control/Status Register (TRCSR)
- Rate/Mode Control Register (RMCR)
- Receive Data Register (RDR)
- Receive Data Shift Register (RDSR)
- Transmit Data Register (TDR)
- Transmit Data Shift Register (TDSR)

The serial I/O hardware requires an initialization by software for operation. The procedure is usually as follows:

- 1) Write a desirable operation mode into each corresponding control bit of the RMCR.
- 2) Write a desirable operation mode into each corresponding control bit of the TRCSR.

When using bit 3 and 4 of port 2 for serial I/O only, there is no problem even if TE and RE bit are set. But when setting the baud rate and operation mode, TE and RE should be "0". When clearing TE and RE bit and setting them again, more than 1 bit cycle of the current baud rate is necessary. If set in less than 1 bit cycle, there may be a case that the internal transmit/receive initialization fails.

● Asynchronous Mode

An asynchronous mode contains the following two data formats:

- 1 Start Bit + 8 Bit Data + 1 Stop Bit
- 1 Start Bit + 9 Bit Data + 1 Stop Bit

In addition, if the 9th bit is set to "1" when making 9 bit data format, the format of

- 1 Start bit + 8 Bit Data + 2 Stop Bit

is also transferred.

Data transmission is enabled by setting TE bit of the TRCSR, then port 2, bit 4 will become a serial output independently of the corresponding DDR.

For data transmit, both the RMCR and TRCSR should be set under the desirable operating conditions. When TE bit is set during this process, 10 bit preamble will be sent in 8-bit data format and 11 bit in 9-bit data format. When the preamble is produced, the internal synchronization will become stable and the transmitter is ready to act.

The conditions at this stage are as follows.

- 1) If the TDR is empty (TDRE=1), consecutive 1's are produced to indicate the idle state.

- 2) If the TDR contains data (TDRE=0), data is sent to the transmit data shift register and data transmit starts.

During data transmit, a start bit of "0" is transmitted first. Then 8-bit or 9-bit data (starts from bit 0) and a stop bit "1" are transmitted.

When the TDR is "empty", hardware sets TDRE flag bit. If the CPU doesn't respond to the flag in proper timing (the TDRE is in set condition till the next normal data transfer starts from the transmit data register to the transmit shift register), "1" is transferred instead of the start bit "0" and continues to be transferred till data is provided to the data register. While the TDRE is "1", "0" is not transferred.

Data receive is possible by setting RE bit. This makes port 2, bit 3 be a serial input. The operation mode of data receive is decided by the contents of the TRCSR and RMCR. The first "0" (space) synchronizes the receive bit flow. Each bit of the following data will be strobed in the middle. If a stop bit is not "1", a framing error assumed and ORFE is set

When a framing error occurs, receive data is transferred to the receive data register and the CPU can read error-generating data. This makes it possible to detect a line break.

If the stop bit is "1", data is transferred to the receive data register and an interrupt flag RDRF is set. If RDRF is still set when receiving the stop bit of the next data, ORFE is set to indicate overrun generation.

When the CPU read the receive data register as a response to RDRF flag or ORFE flag after having read TRCS, RDRF or ORFE is cleared.

(Note) Clock Source in Asynchronous Mode

If CC1 : CC0 = 10, the internal bit rate clock is provided at P₂₂ regardless of the values for TE or RE. Maximum clock rate is E ÷ 16.

If both CC1 and CC0 are set, an external TTL compatible clock must be connected to P₂₂ at sixteen times (16×) the desired bit rate, but not greater than E.

● Clocked Synchronous Mode

In the clocked synchronous mode, data transmit is synchronized with the clock pulse. The HD6303X SCI provides functionally independent transmitter and receiver which makes full duplex operation possible in the asynchronous mode. But in the clocked synchronous mode an SCI clock I/O pin is only P₂₂, so the simultaneous receive and transmit operation is not available. In this mode, TE and RE should not be in set condition ("1") simultaneously. Fig. 21 gives a synchronous clock and a data format in the clocked synchronous mode.



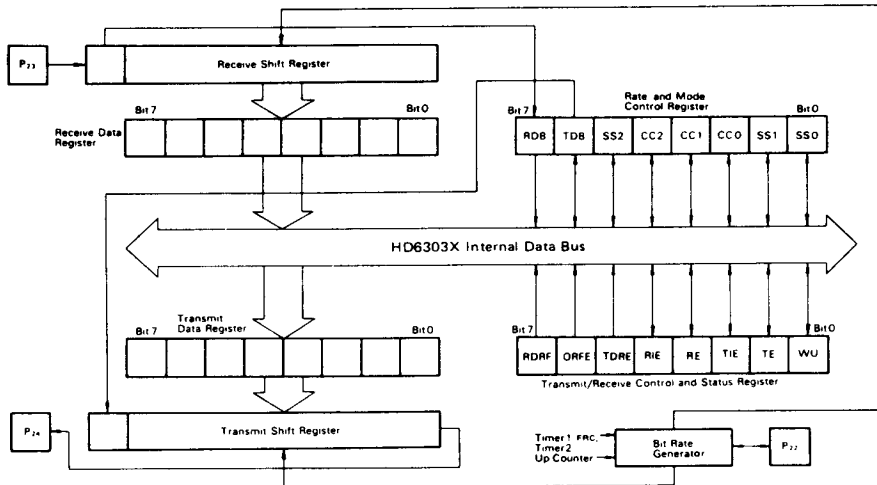

Figure 20 Serial Communication Interface Block Diagram

Data transmit is realized by setting TE bit in the TRCSR. Port 2, bit 4 becomes an output unconditionally independent of the value of the corresponding DDR.

Both the RMR and TRCSR should be set in the desirable operating condition for data transmit.

When an external clock input is selected, data transmit is

performed under the TDRE flag "0" from port 2, bit 4, synchronizing with 8 clock pulses input from external to port 2, bit 2.

Data is transmitted from bit 0 and the TDRE is set when the transmit data shift register is "empty". More than 9th clock pulse of external are ignored.

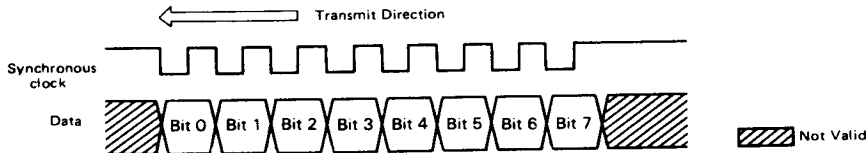

- Transmit data is output from a falling edge of a synchronous clock to the next falling edge.
- Receive data is latched at the rising edge.

Figure 21 Clocked Synchronous Mode Format

When data transmit is selected to the clock output, the MPU produces transmit data and synchronous clock at TDRE flag clear.

Data receive is enabled by setting RE bit. Port 2, bit 3 will be a serial input. The operating mode of data receive is decided by the TRCSR and the RMR.

If the external clock input is selected, RE bit should be set when P22 is "High". Then 8 external clock pulses and the synchronized receive data are input to port 2, bit 2 and bit 3 respectively. The MPU put receive data into the receive data shift register by this clock and set the RDRF flag at the termination of 8 bit data receive. More than 9th clock pulse of external input are ignored. When RDRF is cleared by reading the receive data register, the MPU starts

receiving the next data. So RDRF should be cleared with P22 "High"

When data receive is selected to the clock output, 8 synchronous clocks are output to the external by setting RE bit. So receive data should be input from external, synchronously with this clock. When the first byte data is received, the RDRF flag is set. After the second byte, receive operation is performed and output the synchronous clock to the external by clearing the RDRF bit.

• **Transmit/Receive Control Status Register (TRCSR) (\$0011)**

The TRCSR is composed of 8 bits which are all readable. Bits 0 to 4 are also writable. This register is initialized to \$20 during reset. Each bit functions as follows.



HD6303X, HD63A03X, HD63B03X

Transmit/Receive Control Status Register

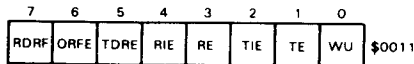

Bit 0 WU Wake-up

In a typical multi-processor configuration, the software protocol provides the destination address at the first byte of the message. In order to make uninterested MPU ignore the remaining message, a wake-up function is available. By this, uninterested MPU can inhibit all further receive processing till the next message starts.

Then wake-up function is triggered by consecutive 1's with 1 frame length (10 bits for 8-bit data, 11 for 9-bit). The software protocol should provide the idle time between messages.

By setting this bit, the MPU stops data receive till the next message. The receive of consecutive "1" with one frame length wakes up and clears this bit and then the MPU restarts receive operation. However, the RE flag should be already set before setting this bit. In the clocked synchronous mode WU is not available, so this bit should not be set.

Bit 1 TE Transmit Enable

When this bit is set, transmit data will appear at port 2, bit 4 after one frame preamble in asynchronous mode, while in clocked synchronous mode it appears immediately. This is executed regardless of the value of the corresponding DDR. When TE is cleared, the serial I/O doesn't affect port 2, bit 4.

Bit 2 TIE Transmit Interrupt Enable

When this bit is set, an internal interrupt (IRQ₃) is enabled when TDRE (bit 5) is set. When cleared, the interrupt is inhibited.

Bit 3 RE Receive Enable

When set, a signal is input to the receiver from port 2, bit 3 regardless of the value of the DDR. When RE is cleared, the serial I/O doesn't affect port 2, bit 3.

Bit 4 RIE Receive Interrupt Enable

When this bit is set, an internal interrupt, IRQ₃ is enabled when RDRF (bit 7) or ORFE (bit 6) is set. When cleared, the interrupt is inhibited.

Bit 5 TDRE Transmit Data Register Empty

TDRE is set when the TDR is transferred to the transmit data shift register in the asynchronous mode, while in clocked synchronous mode when the TDSR is "empty". This bit is reset by reading the TRCSR and writing new transmit data to the transmit data register. TDRE is set to "1" during reset.

(Note) TDRE should be cleared in the transmittable state after the TE set.

Bit 6 ORFE Overrun Framing Error

ORFE is set by hardware when an overrun or a framing error is generated (during data receive only). An overrun error occurs when new receive data is ready to

be transferred to the RDR during RDRF still being set. A framing error occurs when a stop bit is "0". But in clocked synchronous mode, this bit is not affected. This bit is cleared when reading the TRCSR, then the RDR, or during reset.

Bit 7 RDRF Receive Data Register Full

RDRF is set by hardware when the RDSR is transferred to the RDR. Cleared when reading the TRCSR, then the RDR, or during reset.

(Note) When a few bits are set between bit 5 to bit 7 in the TRCSR, a read of the TRCSR is sufficient for clearing those bits. It is not necessary to read the TRCSR every-time to clear each bit.

• Transmit Rate/Mode Control Register (RMCR)

The RMCR controls the following serial I/O:

- Baud Rate
- Data Format
- Clock Source
- Port 2, Bit 2 Function

In addition, if 9-bit data format is set in the asynchronous mode, the 9th bit is put in this register. All bits are readable and writable except bit 7 (read only). This register is set to \$00 during reset.

Transfer Rate/Mode Control Register

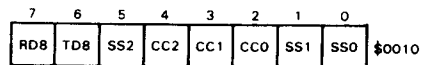

- Bit 0 SS0
 - Bit 1 SS1
 - Bit 5 SS2
- } Speed Select

These bits control the baud rate used for the SCI. Table 6 lists the available baud rates. The timer 1 FRC (SS2=0) and the timer 2 up counter (SS2=1) provide the internal clock to the SCI. When selecting the timer 2 as a baud rate source, it functions as a baud rate generator. The timer 2 generates the baud rate listed in Table 7 depending on the value of the TCONR.

(Note) When operating the SCI with internal clock, do not perform write operation to the timer/counter which is the clock source of the SCI.

- Bit 2 CC0
 - Bit 3 CC1
 - Bit 4 CC2
- } Clock Control/Format Select*

These bits control the data format and the clock source (refer to Table 8).

* CC0, CC1 and CC2 are cleared during reset and the MPU goes to the clocked synchronous mode of the external clock operation. Then the MPU sets port 2, bit 2 into the clock input state. When using port 2, bit 2 as an output port, the DDR of port 2 should be set to "1" and CC1 and CC0 to "0" and "1" respectively.



HD6303X, HD63A03X, HD63B03X

Table 6 SCI Bit Times and Transfer Rates

(1) Asynchronous Mode

SS2	SS1	SS0	XTAL	2.4576MHz	4.0MHz	4.9152MHz
			E	614.4kHz	1.0MHz	1.2288MHz
0	0	0	E ÷ 16	26 μs/38400Baud	16 μs/62500Baud	13 μs/76800Baud
0	0	1	E ÷ 128	208 μs/4800Baud	128 μs/7812.5Baud	104.2 μs/9600Baud
0	1	0	E ÷ 1024	1.67ms/600Baud	1.024ms/976.6Baud	833.3 μs/1200Baud
0	1	1	E ÷ 4096	6.67ms/150Baud	4.096ms/244.1Baud	3.333ms/300Baud
1	—	—	—	*	*	*

* When SS2 is "1", Timer 2 provides SCI clocks. The baud rate is shown as follows with the TCONR as N.

$$\text{Baud Rate} = \frac{f}{32(N+1)} \quad \left(\begin{array}{l} f: \text{input clock frequency to the} \\ \text{timer 2 counter} \\ N = 0 \sim 255 \end{array} \right)$$

(2) Clocked Synchronous Mode *

SS2	SS1	SS0	XTAL	4.0MHz	6.0MHz	8.0MHz
			E	1.0MHz	1.5MHz	2.0MHz
0	0	0	E ÷ 2	2 μs/bit	1.33 μs/bit	1 μs/bit
0	0	1	E ÷ 16	16 μs/bit	10.7 μs/bit	8 μs/bit
0	1	0	E ÷ 128	128 μs/bit	85.3 μs/bit	64 μs/bit
0	1	1	E ÷ 512	512 μs/bit	341 μs/bit	256 μs/bit
1	—	—	—	**	**	**

* Bit rates in the case of internal clock operation. In the case of external clock operation, the external clock is operatable up to DC ~ 1/2 system clock.

** The bit rate is shown as follows with the TCONR as N.

$$\text{Bit Rate } (\mu\text{s/bit}) = \frac{4(N+1)}{f} \quad \left(\begin{array}{l} f: \text{input clock frequency to the} \\ \text{timer 2 counter} \\ N = 0 \sim 255 \end{array} \right)$$

Table 7 Baud Rate and Time Constant Register Example

Baud Rate (Baud)	XTAL	2.4576MHz	3.6864MHz	4.0MHz	4.9152MHz	8.0MHz
110		21'	32'	35'	43'	70'
150		127	191	207	255	51'
300		63	95	103	127	207
600		31	47	51	63	103
1200		15	23	25	31	51
2400		7	11	12	15	25
4800		3	5	—	7	12
9600		1	2	—	3	—
19200		0	—	—	1	—
38400		—	—	—	0	—

* E/8 clock is input to the timer 2 up counter and E clock otherwise.



HD6303X, HD63A03X, HD63B03X

Table 8 SCI Format and Clock Source Control

CC2	CC1	CC0	Format	Mode	Clock Source	Port 2, Bit 2	Port 2, Bit 3	Port 2, Bit 4
0	0	0	8-bit data	Clocked Synchronous	External	Input	When the TRCSR, RE bit is "1", bit 3 is used as a serial input.	
0	0	1	8-bit data	Asynchronous	Internal	Not Used**		
0	1	0	8-bit data	Asynchronous	Internal	Output*		
0	1	1	8-bit data	Asynchronous	External	Input		
1	0	0	8-bit data	Clocked Synchronous	Internal	Output	When the TRCSR, TE bit is "1", bit 4 is used as a serial output.	
1	0	1	9-bit data	Asynchronous	Internal	Not Used**		
1	1	0	9-bit data	Asynchronous	Internal	Output*		
1	1	1	9-bit data	Asynchronous	External	Input		

* Clock output regardless of the TRCSR, bit RE and TE.

** Not used for the SCI.

Bit 6 TD8 Transmit Data Bit 8

When selecting 9-bit data format in the asynchronous mode, this bit is transmitted as the 9th data. In transmitting 9-bit data, write the 9th data into this bit then write data to the receive data register.

Bit 7 RD8 Receive Data Bit 8

When selecting 9-bit data format in the asynchronous mode, this bit stores the 9th bit data. In receiving 9-bit data, read this bit then the receive data register.

■ PRECAUTION 1

In the synchronous clocked receive operation with clock-output, there are three cases for clock pulse timing after RDRF clear as shown below.

Please consider above in designing system, since transmitting receiving time is not uniform.

The clock-output of case 1 or case 2 is determined by "1" or "0" of SCI internal operation clock of RDRF clearing cycle. In addition, in the case of low voltage operation ($V_{CC} < 4.5V$), the clock-output of case 1 may transfer to case 3.

■ PRECAUTION 2

When transmitting through clock-synchronous serial communication interface, TE bit should not be cleared with TDRE of TRCSR (\$11) is "0".

The TDRE set and clear conditions of SCI are shown as follows.

	Set condition	Clear condition
TDRE	<ol style="list-style-type: none"> 1. TDR → transmit shift register (asynchronous) 2. Transmit shift register is empty. (clock-synchronous) 3. RES = 0 	When writing to TDR after TRCSR read, with TDRE = 1, TDRE is cleared.

If transmit data is written to TDR, and then TE bit is cleared with TDRE = 0 to stop transmitting, TDRE remains "0".

In this case, even if TE bit is set and transmit data is written again, the TDR data is not transmitted.

Please note that TE bit must be cleared after the last data has been transmitted.

(This caution is not applied to asynchronous serial communication interface.)

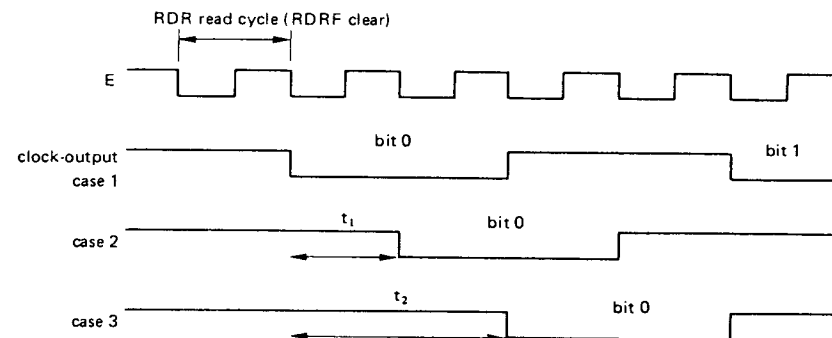

(note) When bit rate is $E/2$, $t_1 = E$, and $t_2 = 2E$. $E/128$, $t_1 = 64E$, $t_2 = 128E$.
 $E/16$, $t_1 = 8E$, $t_2 = 16E$. $E/512$, $t_1 = 256E$, $t_2 = 512E$.

Precaution 1 Diagram



HD6303X, HD63A03X, HD63B03X

■ TIMER, SCI STATUS FLAG

Table 9 shows the set and reset conditions of each status flag in the timer 1, timer 2 and SCI.

As for Timer 1 and Timer 2 status flag, if the set and reset condition occur simultaneously, the set condition is prior to the reset condition. But in case of SCI control status flag, the reset condition has priority. Especially as for OCF1 and

OCF2 of Timer 1, the set signal is generated periodically whenever FRC matches OCR after the set, and which can cause the unclear of the flag. To clear surely, the method is necessary to avoid the occurrence of the set signal between TCSR Read and OCR write. For example, match the OCR value to FRC first, and next read TCSR, and then write OCR at once.

Table 9 Timer 1, Timer 2 and SCI Status Flag

		Set Condition	Reset Condition
Timer 1	ICF	FRC → ICR by edge input to P ₂₀ .	1. Read the TCSR1 or TCSR2 then ICRH, when ICF = 1 2. \overline{RES} =0
	OCF1	OCR1=FRC	1. Read the TCSR1 or TCSR2 then write to the OCR1H or OCR1L, when OCF1=1 2. \overline{RES} =0
	OCF2	OCR2=FRC	1. Read the TCSR2 then write to the OCR2H or OCR2L, when OCF2=1 2. \overline{RES} =0
	TOF	FRC=\$FFFF+1 cycle	1. Read the TCSR1 then FRCH, when TOF = 1 2. \overline{RES} =0
Timer 2	CMF	T2CNT=TCONR	1. Write "0" to CMF, when CMF = 1 2. \overline{RES} =0
	RDRF	Receive Shift Register → RDR	1. Read the TRCSR then RDR, when RDRF = 1 2. \overline{RES} =0
SCI	ORFE	1. Framing Error (Asynchronous Mode) Stop Bit = 0 2. Overrun Error (Asynchronous Mode) Receive Shift Register → RDR when RDRF=1	1. Read the TRCSR then RDR, when ORFE = 1 2. \overline{RES} =0
	TDRE	1. Asynchronous Mode TDR → Transmit Shift Register 2. Clocked Synchronous Mode Transmit Shift Register is "empty" 3. \overline{RES} =0	Read the TRCSR then write to the TDR, when TDRE = 1 (Note) TDRE should be reset after the TE set.

(Note) 1. →; transfer
2. For example; "ICRH" means High byte of ICR.

■ LOW POWER DISSIPATION MODE

The HD6303X provides two low power dissipation modes: sleep and standby.

● Sleep Mode

The MPU goes to the sleep mode by SLP instruction execution. In the sleep mode, the CPU stops its operation, while the registers' contents are retained. In this mode, the peripherals except the CPU such as timers, SCI etc. continue their functions. The power dissipation of sleep-condition is one fifth that of operating condition.

The MPU returns from this mode by an interrupt, \overline{RES} or \overline{STBY} ; it goes to the reset state by \overline{RES} and the standby mode by \overline{STBY} . When the CPU acknowledges an interrupt request, it cancels the sleep mode, returns to the operation mode and branches to the interrupt routine. When the CPU masks this interrupt, it cancels the sleep mode and executes the next instruction. However, for example if the timer 1 or 2 prohibits a timer interrupt, the CPU doesn't cancel the sleep mode because of no interrupt request.

This sleep mode is effective to reduce the power dissipation

for a system with no need of the HD6303X's consecutive operation.

● Standby Mode

The HD6303X stops all the clocks and goes to the reset state with \overline{STBY} "Low". In this mode, the power dissipation is reduced conspicuously. All pins except for the power supply, the \overline{STBY} and XTAL are detached from the MPU internally and go to the high impedance state.

In this mode the power is supplied to the HD6303X, so the contents of RAM is retained. The MPU returns from this mode during reset. The followings are typical usage of this mode.

Save the CPU information and SP contents on RAM by \overline{NMI} . Then disable the RAME bit of the RAM control register and set the \overline{STBY} PWR bit to go to the standby mode. If the \overline{STBY} PWR bit is still set at reset start, that indicates the power is supplied to the MPU and RAM contents are retained properly. So system can restore itself by returning their pre-standby informations to the SP and the CPU. Fig. 22 depicts the timing at each pin with this example.

2



HD6303X, HD63A03X, HD63B03X

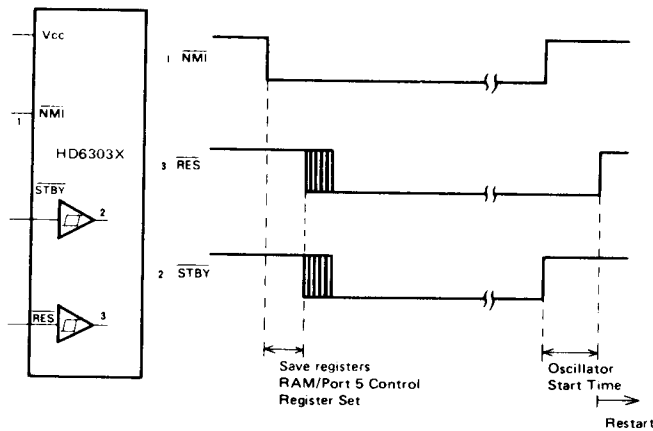

Figure 22 Standby Mode Timing

TRAP FUNCTION

The CPU generates an interrupt with the highest priority (TRAP) when fetching an undefined instruction or an instruction from non-memory space. The TRAP prevents the system-burst caused by noise or a program error.

Op Code Error

When fetching an undefined op code, the CPU saves CPU registers as well as a normal interrupt and branches to the TRAP (SFEE, SFEEF). This has the priority next to reset.

Address Error

When an instruction fetch is made from internal register (S0000~S001F), the MPU generates an interrupt as well as an op code error. But on the system with no memory in its external memory area, this function is not applicable if an instruction fetch is made from the external non-memory area.

This function is available only for an instruction fetch and is not applicable to the access of normal data read/write.

(Note) The TRAP interrupt provides a retry function differently from other interrupts. This is a program flow return to the address where the TRAP occurs when a sequence returns to a main routine from the TRAP interrupt routine by RTI. The retry can prevent the system burst caused by noise etc.

However, if another TRAP occurs, the program repeats the TRAP interrupt forever, so the consideration is necessary in programming.

INSTRUCTION SET

The HD6303X provides object code upward compatible with the HD6801 to utilize all instruction set of the HMCS6800. It also reduces the execution times of key instructions for throughput improvement.

Bit manipulation instruction, change instruction of the index register and accumulator and sleep instruction are also added.

The followings are explained here.

- CPU Programming Model (refer to Fig. 23)
- Addressing Mode

- Accumulator and Memory Manipulation Instruction (refer to Table 10)
- New Instruction
- Index Register and Stack Manipulation Instruction (refer to Table 11)
- Jump and Branch Instruction (refer to Table 12)
- Condition Code Register Manipulation (refer to Table 13)
- Op Code Map (refer to Table 14)

Programming Model

Fig. 23 depicts the HD6303X programming model. The double accumulator D consists of accumulator A and B, so when using the accumulator D, the contents of A and B are destroyed.

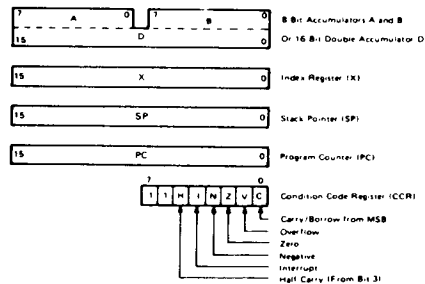

Figure 23 CPU Programming Model

CPU Addressing Mode

The HD6303X provides 7 addressing modes. The addressing mode is decided by an instruction type and code. Table 10 through 14 show addressing modes of each instruction with the execution times counted by the machine cycle.

When the clock frequency is 4 MHz, the machine cycle time



becomes microseconds directly.

Accumulator (ACCX) Addressing

Only an accumulator is addressed and the accumulator A or B is selected. This is a one-byte instruction.

Immediate Addressing

This addressing locates a data in the second byte of an instruction. However, LDS and LDX locate a data in the second and third byte exceptionally. This addressing is a 2 or 3-byte instruction.

Direct Addressing

In this addressing mode, the second byte of an instruction shows the address where a data is stored. 256 bytes (\$0 through \$255) can be addressed directly. Execution times can be reduced by storing data in this area so it is recommended to make it RAM for users' data area in configuring a system. This is a 2-byte instruction, while 3-byte with regard to AIM, OIM, EIM and TIM.

Extended Addressing

In this mode, the second byte shows the upper 8 bit of the data stored address and the third byte the lower 8 bit. This indicates the absolute address of 3-byte instruction in the memory.

Indexed Addressing

The second byte of an instruction and the lower 8 bit of the index register are added in this mode. As for AIM, OIM, EIM and TIM, the third byte of an instruction and the lower 8 bits of the index register are added.

This carry is added to the upper 8 bit of the index register and the result is used for addressing the memory. The modified address is retained in the temporary address register, so the contents of the index register doesn't change. This is a 2-byte instruction except AIM, OIM, EIM and TIM (3-byte instruction).

Implied Addressing

An instruction itself specifies the address. That is, the instruction addresses a stack pointer, index register etc. This is a one-byte instruction.

Relative Addressing

The second byte of an instruction and the lower 8 bits of the program counter are added. The carry or borrow is added to the upper 8 bit. So addressing from -126 to +129 byte of the current instruction is enabled. This is a 2-byte instruction.

(Note) CLI, SEI Instructions and Interrupt Operation

When accepting the IRQ at a preset timing with CLI and SEI instructions, more than 2 cycles are necessary between the CLI and SEI instructions. For example, the following program (a) (b) don't accept the IRQ but (c) accepts it.

.	.	.
.	.	.
.	.	.
.	.	CLI
CLI	CLI	NOP
SEI	NOP	NOP
.	SEI	SEI
.	.	.
.	.	.
.	.	.
.	.	.
(a)	(b)	(c)

The same thing can be said to the TAP instruction instead of the CLI and SEI instructions.



HD6303X, HD63A03X, HD63B03X

Table 10 Accumulator, Memory Manipulation Instructions

Operations	Mnemonic	Addressing Modes												Boolean/ Arithmetic Operation	Condition Code Register																			
		IMMED		DIRECT		INDEX		EXTEND		IMPLIED		Register																						
		OP	#	OP	#	OP	#	OP	#	OP	#	5	4		3	2	1	0																
Add	ADDA	8B	2	2	9B	3	2	AB	4	2	BB	4	3															A + M → A	·	·	·	·	·	·
	ADDB	CB	2	2	DB	3	2	EB	4	2	FB	4	3															B + M → B	·	·	·	·	·	·
Add Double	ADDD	C3	3	3	D3	4	2	E3	5	2	F3	5	3															A : B + M : M + 1 → A : B	·	·	·	·	·	·
Add Accumulators	ABA													1B	1	1												A + B → A	·	·	·	·	·	·
Add With Carry	ADCA	89	2	2	99	3	2	A9	4	2	B9	4	3															A + M + C → A	·	·	·	·	·	·
	ADCB	C9	2	2	D9	3	2	E9	4	2	F9	4	3															B + M + C → B	·	·	·	·	·	·
AND	ANDA	84	2	2	94	3	2	A4	4	2	B4	4	3															A · M → A	·	·	·	·	·	·
	ANDB	C4	2	2	D4	3	2	E4	4	2	F4	4	3															B · M → B	·	·	·	·	·	·
Bit Test	BIT A	85	2	2	95	3	2	A5	4	2	B5	4	3															A · M	·	·	·	·	·	·
	BIT B	C5	2	2	D5	3	2	E5	4	2	F5	4	3															B · M	·	·	·	·	·	·
Clear	CLR							6F	5	2	7F	5	3															00 → M	·	·	·	·	·	·
	CLRA													4F	1	1												00 → A	·	·	·	·	·	·
	CLRB													5F	1	1												00 → B	·	·	·	·	·	·
Compare	CMPA	81	2	2	91	3	2	A1	4	2	B1	4	3															A - M	·	·	·	·	·	·
	CMPB	C1	2	2	D1	3	2	E1	4	2	F1	4	3															B - M	·	·	·	·	·	·
Compare Accumulators	CBA													11	1	1												A - B	·	·	·	·	·	·
Complement, 1's	COM							63	6	2	73	6	3															M → M	·	·	·	·	·	·
	COMA													43	1	1												A → A	·	·	·	·	·	·
	COMB													53	1	1												B → B	·	·	·	·	·	·
Complement, 2's (Negate)	NEG							60	6	2	70	6	3															00 → M → M	·	·	·	·	·	·
	NEGA													40	1	1												00 → A → A	·	·	·	·	·	·
	NEGB													50	1	1												00 → B → B	·	·	·	·	·	·
Decimal Adjust, A	DAA												19	2	1												Converts binary add of BCD characters into BCD format	·	·	·	·	·	·	
Decrement	DEC							6A	6	2	7A	6	3															M - 1 → M	·	·	·	·	·	·
	DECA													4A	1	1												A - 1 → A	·	·	·	·	·	·
	DECB													5A	1	1												B - 1 → B	·	·	·	·	·	·
Exclusive OR	EORA	88	2	2	98	3	2	AB	4	2	BB	4	3															A ⊕ M → A	·	·	·	·	·	·
	EORB	C8	2	2	D8	3	2	EB	4	2	FB	4	3															B ⊕ M → B	·	·	·	·	·	·
Increment	INC							6C	6	2	7C	6	3															M + 1 → M	·	·	·	·	·	·
	INCA													4C	1	1												A + 1 → A	·	·	·	·	·	·
	INCB													5C	1	1												B + 1 → B	·	·	·	·	·	·
Load Accumulator	LDA A	86	2	2	96	3	2	A6	4	2	B6	4	3															M → A	·	·	·	·	·	·
	LDA B	C6	2	2	D6	3	2	E6	4	2	F6	4	3															M → B	·	·	·	·	·	·
Load Double Accumulator	LDD	CC	3	3	DC	4	2	EC	5	2	FC	5	3															M + 1 → B, M → A	·	·	·	·	·	·
Multiply Unsigned	MUL													3D	7	1												A × B → A : B	·	·	·	·	·	·
OR, Inclusive	ORAA	8A	2	2	9A	3	2	AA	4	2	BA	4	3															A + M → A	·	·	·	·	·	·
	ORAB	CA	2	2	DA	3	2	EA	4	2	FA	4	3															B + M → B	·	·	·	·	·	·
Push Data	PSHA													36	4	1												A - Msp, SP - 1 → SP	·	·	·	·	·	·
	PSHB													37	4	1												B - Msp, SP - 1 → SP	·	·	·	·	·	·
	PULA													32	3	1												SP + 1 → SP, Msp → A	·	·	·	·	·	·
Pull Data	PULB													33	3	1												SP + 1 → SP, Msp → B	·	·	·	·	·	·
	ROL							69	6	2	79	6	3															M	·	·	·	·	·	·
Rotate Left	ROLA													49	1	1												A	·	·	·	·	·	·
	ROLB													59	1	1												B	·	·	·	·	·	·
	ROR							66	6	2	76	6	3															M	·	·	·	·	·	·
	RORA													46	1	1												A	·	·	·	·	·	·
Rotate Right	RORB													56	1	1												B	·	·	·	·	·	·

(Note) Condition Code Register will be explained in Note of Table 13.

(continued)



HD6303X, HD63A03X, HD63B03X

Table 10 Accumulator, Memory Manipulation Instructions

Operations	Mnemonic	Addressing Modes										Boolean/ Arithmetic Operation	Condition Code Register															
		IMMED.		DIRECT		INDEX		EXTEND		IMPLIED			5	4	3	2	1	0										
		OP	~ #	OP	~ #	OP	~ #	OP	~ #	OP	~ #		H	N	Z	V	C											
Shift Left Arithmetic	ASL							68	6	2	78	6	3	M						•	•	•	•	Ⓢ	•			
	ASLA												48	1	1	A						•	•	•	•	Ⓢ	•	
	ASLB													58	1	1	B						•	•	•	•	Ⓢ	•
Double Shift Left, Arithmetic	ASLD													05	1	1	C						•	•	•	•	Ⓢ	•
Shift Right Arithmetic	ASR							67	6	2	77	6	3	M						•	•	•	•	Ⓢ	•			
	ASRA													47	1	1	A						•	•	•	•	Ⓢ	•
	ASRB													57	1	1	B						•	•	•	•	Ⓢ	•
Shift Right Logical	LSR							64	6	2	74	6	3	M						•	•	•	•	Ⓢ	•			
	LSRA													44	1	1	A						•	•	•	•	Ⓢ	•
	LSRB													54	1	1	B						•	•	•	•	Ⓢ	•
Double Shift Right Logical	LSRD													04	1	1	C						•	•	•	•	Ⓢ	•
Store Accumulator	STAA				97	3	2	A7	4	2	B7	4	3		A - M		• • • • • R •											
	STAB				D7	3	2	E7	4	2	F7	4	3		B - M		• • • • • R •											
Store Double Accumulator	STD				DD	4	2	ED	5	2	FD	5	3		A - M B - M + 1		• • • • • R •											
	SUBA	80	2	2	90	3	2	A0	4	2	B0	4	3		A - M - A		• • • • • R •											
Subtract	SUBB	CD	2	2	D0	3	2	E0	4	2	F0	4	3		B - M - B		• • • • • R •											
	SUBD	83	3	3	93	4	2	A3	5	2	B3	5	3		A - B - M + 1 - A - B		• • • • • R •											
Subtract Accumulators	SBA												10	1	1		A - B - A		• • • • • R •									
Subtract With Carry	SBCA	82	2	2	92	3	2	A2	4	2	B2	4	3		A - M - C - A		• • • • • R •											
	SBCB	C2	2	2	D2	3	2	E2	4	2	F2	4	3		B - M - C - B		• • • • • R •											
Transfer Accumulators	TAB												16	1	1		A - B		• • • • • R •									
	TBA												17	1	1		B - A		• • • • • R •									
Test Zero or Minus	TST							6D	4	2	7D	4	3		M - 00		• • • • • R R											
	TSTA												4D	1	1		A - 00		• • • • • R R									
	TSTB												5D	1	1		B - 00		• • • • • R R									
And Immediate	AIM				71	6	3	61	7	3		M - IMM - M		• • • • • R •														
OR Immediate	OIM				72	6	3	62	7	3		M + IMM - M		• • • • • R •														
EOR Immediate	EIM				75	6	3	65	7	3		M + IMM - M		• • • • • R •														
Test Immediate	TIM				7B	4	3	6B	5	3		M - IMM		• • • • • R •														

(Note) Condition Code Register will be explained in Note of Table 13.



HD6303X, HD63A03X, HD63B03X

• **Additional Instruction**

In addition to the HD6801 instruction set, the HD6303X prepares the following new instructions.

AIM (M) · (IMM) → (M)

Executes "AND" operation to immediate data and the memory contents and stores its result in the memory.

OIM (M) + (IMM) → (M)

Executes "OR" operation to immediate data and the memory contents and stores its result in the memory.

EIM (M) ⊕ (IMM) → (M)

Executes "EOR" operation to immediate data and the memory contents and stores its result in the memory.

TIM (M) · (IMM)

Executes "AND" operation to immediate data and changes the relative flag of the condition code register.

These area 3-byte instructions; the first byte is op code, the second immediate data and the third address modifier.

XGDX (ACCD) ↔ (IX)

Exchanges the contents of accumulator and the index register.

SLP

Goes to the sleep mode. Refer to "LOW POWER DISSIPATION MODE" for more details of the sleep mode.

Table 11 Index Register, Stack Manipulation Instructions

Pointer Operations	Mnemonic	Addressing Modes												Boolean/ Arithmetic Operation	Condition Code Register												
		IMMED		DIRECT		INDEX		EXTEND		IMPLIED		H	I		N	Z	V	C									
		OP	#	OP	#	OP	#	OP	#	OP	#																
Compare Index Reg	CPX	BC	3	3	9C	4	2	AC	5	2	BC	5	3			X - M + 1	•	•	•	•	•	•	•	•	•	•	
Decrement Index Reg	DEX													09	1	1	X - 1 → X	•	•	•	•	•	•	•	•	•	•
Decrement Stack Ptr	DES													34	1	1	SP - 1 → SP	•	•	•	•	•	•	•	•	•	•
Increment Index Reg	INX													08	1	1	X + 1 → X	•	•	•	•	•	•	•	•	•	•
Increment Stack Ptr	INS													31	1	1	SP + 1 → SP	•	•	•	•	•	•	•	•	•	•
Load Index Reg	LDX	CE	3	3	DE	4	2	EE	5	2	FE	5	3				M → X _H , (M + 1) → X _L	•	•	•	•	•	•	•	•	•	•
Load Stack Ptr	LDS	BE	3	3	9E	4	2	AE	5	2	BE	5	3				M → SP _H , (M + 1) → SP _L	•	•	•	•	•	•	•	•	•	•
Store Index Reg	STX				DF	4	2	EF	5	2	FF	5	3				X _H → M, X _L → (M + 1)	•	•	•	•	•	•	•	•	•	•
Store Stack Ptr	STS				9F	4	2	AF	5	2	BF	5	3				SP _H → M, SP _L → (M + 1)	•	•	•	•	•	•	•	•	•	•
Index Reg → Stack Ptr	TXS													35	1	1	X - 1 → SP	•	•	•	•	•	•	•	•	•	•
Stack Ptr → Index Reg	TSX													30	1	1	SP + 1 → X	•	•	•	•	•	•	•	•	•	•
Add	ABX													3A	1	1	B + X → X	•	•	•	•	•	•	•	•	•	•
Push Data	PSHX													3C	5	1	X _L → M _{sp} , SP - 1 → SP	•	•	•	•	•	•	•	•	•	•
Pull Data	PULX													38	4	1	X _H → M _{sp} , SP - 1 → SP	•	•	•	•	•	•	•	•	•	•
																	SP + 1 → SP, M _{sp} → X _H										
Exchange	XGDX													18	2	1	ACCD ← X	•	•	•	•	•	•	•	•	•	•

(Note) Condition Code Register will be explained in Note of Table 13.



HD6303X, HD63A03X, HD63B03X

Table 12 Jump, Branch Instructions

Operations	Mnemonic	Addressing Modes												Branch Test	Condition Code Register							
		RELATIVE			DIRECT			INDEX			EXTEND				IMPLIED		5	4	3	2	1	0
		OP	~	#	OP	~	#	OP	~	#	OP	~	#		OP	~	#	H	I	N	Z	V
Branch Always	BRA	20	3	2																		
Branch Never	BRN	21	3	2																		
Branch If Carry Clear	BCC	24	3	2																		
Branch If Carry Set	BCS	25	3	2																		
Branch If = Zero	BEQ	27	3	2																		
Branch If ≥ Zero	BGE	2C	3	2																		
Branch If > Zero	BGT	2E	3	2																		
Branch If Higher	BH ¹	22	3	2																		
Branch If ≤ Zero	BLE	2F	3	2																		
Branch If Lower Or Same	BLS	23	3	2																		
Branch If < Zero	BLT	20	3	2																		
Branch If Minus	BMI	2B	3	2																		
Branch If Not Equal Zero	BNE	26	3	2																		
Branch If Overflow Clear	BVC	28	3	2																		
Branch If Overflow Set	BVS	29	3	2																		
Branch If Plus	BPL	2A	3	2																		
Branch To Subroutine	BSR	8D	5	2																		
Jump	JMP						6E	3	2	7E	3	3										
Jump To Subroutine	JSR					9D	5	2	AD	5	2	8D	6	3								
No Operation	NOP												01	1	1							
Return From Interrupt	RTI												3B	10	1							
Return From Subroutine	RTS												39	5	1							
Software Interrupt	SWI												3F	12	1							
Wait for Interrupt [*]	WAI												3E	9	1							
Sleep	SLP												1A	4	1							

(Note) ^{*} WAI puts R/W high; Address Bus goes to FFFF; Data Bus goes to the three state. Condition Code Register will be explained in Note of Table 13.

2



HD6303X, HD63A03X, HD63B03X

Table 13 Condition Code Register Manipulation Instructions

Operations	Mnemonic	Addressing Modes		Boolean Operation	Condition Code Register								
		OP	~ #		5	4	3	2	1	0			
Clear Carry	CLC	0C	1 1	0 → C	•	•	•	•	•	•	•	•	R
Clear Interrupt Mask	CLI	0E	1 1	0 → I	•	R	•	•	•	•	•	•	•
Clear Overflow	CLV	0A	1 1	0 → V	•	•	•	•	•	•	•	R	•
Set Carry	SEC	0D	1 1	1 → C	•	•	•	•	•	•	•	•	S
Set Interrupt Mask	SEI	0F	1 1	1 → I	•	S	•	•	•	•	•	•	•
Set Overflow	SEV	0B	1 1	1 → V	•	•	•	•	•	•	•	S	•
Accumulator A → CCR	TAP	06	1 1	A → CCR	•	•	•	•	•	•	•	•	Ⓜ
CCR → Accumulator A	TPA	07	1 1	CCR → A	•	•	•	•	•	•	•	•	•

LEGEND

- OP Operation Code (Hexadecimal)
- ~ Number of MCU Cycles
- Msp Contents of memory location pointed to by Stack Pointer
- # Number of Program Bytes
- + Arithmetic Plus
- Arithmetic Minus
- Boolean AND
- + Boolean Inclusive OR
- ⊕ Boolean Exclusive OR
- M Complement of M
- Transfer into
- 0 Bit = Zero
- 00 Byte = Zero

CONDITION CODE SYMBOLS

- H Half-carry from bit 3 to bit 4
- I Interrupt mask
- N Negative (sign bit)
- Z Zero (byte)
- V Overflow, 2's complement
- C Carry/Borrow from/to bit 7
- R Reset Always
- S Set Always
- Ⓜ Set if true after test or clear
- Not Affected

(Note) Condition Code Register Notes: (Bit set if test is true and cleared otherwise)

- 1¹ (Bit V) Test: Result = 10000000?
- 2 (Bit C) Test: Result ≠ 00000000?
- 3 (Bit C) Test: BCD Character of high-order byte greater than 10? (Not cleared if previously set)
- 4² (Bit V) Test: Operand = 10000000 prior to execution?
- 5 (Bit V) Test: Operand = 01111111 prior to execution?
- 6 (Bit V) Test: Set equal to ⊕ C = 1 after the execution of instructions
- 7 (Bit N) Test: Result less than zero? (Bit 15=1)
- 8 (All Bit) Load Condition Code Register from Stack.
- 9 (Bit I) Set when interrupt occurs. If previously set, a Non-Maskable Interrupt is required to exit the wait state.
- 10 (All Bit) Set according to the contents of Accumulator A.
- 11 (Bit C) Result of Multiplication Bit 7=1? (ACCB)

Table 14 OP-Code Map

OP CODE	ACC				IND				EX				ACCA or SP				ACCB or X			
	A	B	IND	EXT	IMM	DIR	IND	EXT	IMM	DIR	IND	EXT	IMM	DIR	IND	EXT				
0000	0	SBA	BRA	TSX	NEG												0			
0001	1	NOP	CBA	BRN	INS	AIM											1			
0010	2			BHI	PULA		OIM										2			
0011	3			BLS	PULB		COM										3			
0100	4	LSRD		BCC	DES		LSR										4			
0101	5	ASLD		BCS	TXS		EIM										5			
0110	6	TAP	TAB	BNE	PSHA		ROR										6			
0111	7	TPA	TBA	BEQ	PSHB		ASR										7			
1000	8	INX	XGDX	BVC	PULX		ASL										8			
1001	9	DEX	DAA	BVS	RTS		ROL										9			
1010	A	CLV	SLP	BPL	ABX		DEC										A			
1011	B	SEV	ABA	BMI	RTI		TIM										B			
1100	C	CLC		BGE	PSHX		INC										C			
1101	D	SEC		BGT	MUL		TST										D			
1110	E	CLI		BGT	WAI		JMP										E			
1111	F	SEI		BLE	SWI		CLR										F			

UNDEFINED OP CODE

* Only each instructions of AIM, OIM, EIM, TIM



■ CPU OPERATION
● CPU Instruction Flow

When operating, the CPU fetches an instruction from a memory and executes the required function. This sequence starts with \overline{RES} cancel and repeats itself limitlessly if not affected by a special instruction or a control signal. SWI, RTI, WAI and SLP instructions change this operation, while \overline{NMI} , \overline{IRQ}_1 , \overline{IRQ}_2 , \overline{IRQ}_3 , HALT and \overline{STBY} control it. Fig. 24 gives the CPU mode transition and Fig. 25 the CPU system flow chart. Table 15 shows CPU operating states and port states.

● Operation at Each Instruction Cycle

Table 16 shows the operation at each instruction cycle. By the pipeline control of the HD6303X, MULT, PUL, DAA and XGDX instructions etc. prefetch the next instruction. So attention is necessary to the counting of the instruction cycles because it is different from the usual one ----- op code fetch to the next instruction op code.

Table 15 CPU Operation State and Port State

Port	Reset	\overline{STBY}^{***}	HALT	Sleep
$A_0 \sim A_7$	H	T	T	H
Port 2	T	T	Keep	Keep
$D_0 \sim D_7$	T	T	T	T
$A_8 \sim A_{15}$	H	T	T	H
Port 5	T	T	T	T
Port 6	T	T	Keep	Keep
Control Signal	•	T	**	•

H : High, L : Low, T : High Impedance
 • \overline{RD} , \overline{WR} , $\overline{R/W}$, \overline{LTR} = H, BA = L
 ** \overline{RD} , \overline{WR} , $\overline{R/W}$ = T, \overline{LTR} , BA = H
 *** E pin goes to high impedance state.

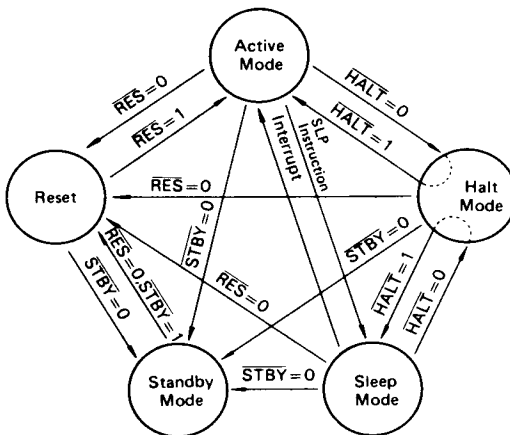

Figure 24 CPU Operation Mode Transition



HD6303X, HD63A03X, HD63B03X

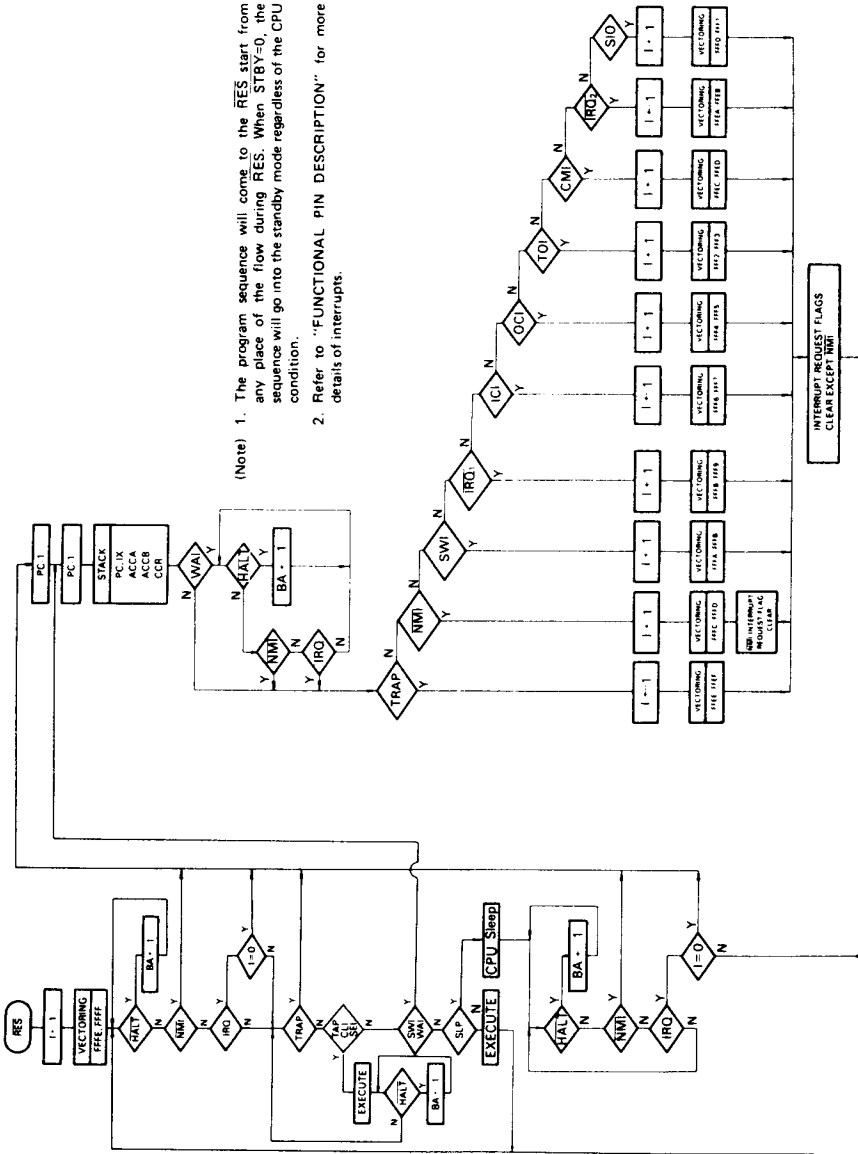

Figure 25 HD6303X System Flow Chart



HD6303X, HD63A03X, HD63B03X

Table 16 Cycle-by-Cycle Operation

Address Mode & Instructions		Cycles	Cycle #	Address Bus	R/W	RD	WR	LIR	Data Bus
IMMEDIATE									
ADC	ADD	2	1	Op Code Address + 1	1	0	1	1	Operand Data
AND	BIT		2	Op Code Address + 2	1	0	1	0	Next Op Code
CMP	EOR								
LDA	ORA								
SBC	SUB								
ADDD	CPX	3	1	Op Code Address + 1	1	0	1	1	Operand Data (MSB)
LDD	LDS		2	Op Code Address + 2	1	0	1	1	Operand Data (LSB)
LDX	SUBD		3	Op Code Address + 3	1	0	1	0	Next Op Code
DIRECT									
ADC	ADD	3	1	Op Code Address + 1	1	0	1	1	Address of Operand (LSB)
AND	BIT		2	Address of Operand	1	0	1	1	Operand Data
CMP	EOR		3	Op Code Address + 2	1	0	1	0	Next Op Code
LDA	ORA								
SBC	SUB								
STA		3	1	Op Code Address + 1	1	0	1	1	Destination Address
			2	Destination Address	0	1	0	1	Accumulator Data
			3	Op Code Address + 2	1	0	1	0	Next Op Code
ADDD	CPX	4	1	Op Code Address + 1	1	0	1	1	Address of Operand (LSB)
LDD	LDS		2	Address of Operand	1	0	1	1	Operand Data (MSB)
LDX	SUBD		3	Address of Operand + 1	1	0	1	1	Operand Data (LSB)
			4	Op Code Address + 2	1	0	1	0	Next Op Code
STD	STS	4	1	Op Code Address + 1	1	0	1	1	Destination Address (LSB)
STX			2	Destination Address	0	1	0	1	Register Data (MSB)
			3	Destination Address + 1	0	1	0	1	Register Data (LSB)
			4	Op Code Address + 2	1	0	1	0	Next Op Code
JSR		5	1	Op Code Address + 1	1	0	1	1	Jump Address (LSB)
			2	FFFF	1	1	1	1	Restart Address (LSB)
			3	Stack Pointer	0	1	0	1	Return Address (LSB)
			4	Stack Pointer - 1	0	1	0	1	Return Address (MSB)
			5	Jump Address	1	0	1	0	First Subroutine Op Code
TIM		4	1	Op Code Address + 1	1	0	1	1	Immediate Data
			2	Op Code Address + 2	1	0	1	1	Address of Operand (LSB)
			3	Address of Operand	1	0	1	1	Operand Data
			4	Op Code Address + 3	1	0	1	0	Next Op Code
AIM	EIM	6	1	Op Code Address + 1	1	0	1	1	Immediate Data
OIM			2	Op Code Address + 2	1	0	1	1	Address of Operand (LSB)
			3	Address of Operand	1	0	1	1	Operand Data
			4	FFFF	1	1	1	1	Restart Address (LSB)
			5	Address of Operand	0	1	0	1	New Operand Data
			6	Op Code Address + 3	1	0	1	0	Next Op Code

(Continued)

2



HD6303X, HD63A03X, HD63B03X

Address Mode & Instructions		Cycles	Cycle #	Address Bus	R/W	RD	WR	LIR	Data Bus
INDEXED									
JMP		3	1	Op Code Address + 1	1	0	1	1	Offset
			2	FFFF	1	1	1	1	Restart Address (LSB)
			3	Jump Address	1	0	1	0	First Op Code of Jump Routine
ADC	ADD	4	1	Op Code Address + 1	1	0	1	1	Offset
AND	BIT		2	FFFF	1	1	1	1	Restart Address (LSB)
CMP	EOR		3	IX + Offset	1	0	1	1	Operand Data
LDA	ORA		4	Op Code Address + 2	1	0	1	0	Next Op Code
SBC	SUB								
TST									
STA		4	1	Op Code Address + 1	1	0	1	1	Offset
			2	FFFF	1	1	1	1	Restart Address (LSB)
			3	IX + Offset	0	1	0	1	Accumulator Data
			4	Op Code Address + 2	1	0	1	0	Next Op Code
ADDD		5	1	Op Code Address + 1	1	0	1	1	Offset
CPX	LDD		2	FFFF	1	1	1	1	Restart Address (LSB)
LDS	LDX		3	IX + Offset	1	0	1	1	Operand Data (MSB)
			4	IX + Offset + 1	1	0	1	1	Operand Data (LSB)
			5	Op Code Address + 2	1	0	1	0	Next Op Code
STD	STS	5	1	Op Code Address + 1	1	0	1	1	Offset
			2	FFFF	1	1	1	1	Restart Address (LSB)
			3	IX + Offset	0	1	0	1	Register Data (MSB)
			4	IX + Offset + 1	0	1	0	1	Register Data (LSB)
			5	Op Code Address + 2	1	0	1	0	Next Op Code
JSR		5	1	Op Code Address + 1	1	0	1	1	Offset
			2	FFFF	1	1	1	1	Restart Address (LSB)
			3	Stack Pointer	0	1	0	1	Return Address (LSB)
			4	Stack Pointer - 1	0	1	0	1	Return Address (MSB)
			5	IX + Offset	1	0	1	0	First Subroutine Op Code
ASL	ASR	6	1	Op Code Address + 1	1	0	1	1	Offset
COM	DEC		2	FFFF	1	1	1	1	Restart Address (LSB)
INC	LSR		3	IX + Offset	1	0	1	1	Operand Data
NEG	ROL		4	FFFF	1	1	1	1	Restart Address (LSB)
			5	IX + Offset	0	1	0	1	New Operand Data
			6	Op Code Address + 2	1	0	1	0	Next Op Code
TIM		5	1	Op Code Address + 1	1	0	1	1	Immediate Data
			2	Op Code Address + 2	1	0	1	1	Offset
			3	FFFF	1	1	1	1	Restart Address (LSB)
			4	IX + Offset	1	0	1	1	Operand Data
			5	Op Code Address + 3	1	0	1	0	Next Op Code
CLR		5	1	Op Code Address + 1	1	0	1	1	Offset
			2	FFFF	1	1	1	1	Restart Address (LSB)
			3	IX + Offset	1	0	1	1	Operand Data
			4	IX + Offset	0	1	0	1	00
			5	Op Code Address + 2	1	0	1	0	Next Op Code
AIM	EIM	7	1	Op Code Address + 1	1	0	1	1	Immediate Data
OIM			2	Op Code Address + 2	1	0	1	1	Offset
			3	FFFF	1	1	1	1	Restart Address (LSB)
			4	IX + Offset	1	0	1	1	Operand Data
			5	FFFF	1	1	1	1	Restart Address (LSB)
			6	IX + Offset	0	1	0	1	New Operand Data
			7	Op Code Address + 3	1	0	1	0	Next Op Code

(Continued)



HD6303X, HD63A03X, HD63B03X

Address Mode & Instructions	Cycles	Cycle #	Address Bus	R	W	RD	WR	LTR	Data Bus
EXTEND									
JMP	3	1	Op Code Address + 1	1	0	1	1	1	Jump Address (MSB)
		2	Op Code Address + 2	1	0	1	1	1	Jump Address (LSB)
		3	Jump Address	1	0	1	0	0	Next Op Code
ADC ADD TST AND BIT CMP EOR LDA ORA SBC SUB	4	1	Op Code Address + 1	1	0	1	1	1	Address of Operand (MSB)
		2	Op Code Address + 2	1	0	1	1	1	Address of Operand (LSB)
		3	Address of Operand	1	0	1	1	1	Operand Data
		4	Op Code Address + 3	1	0	1	0	0	Next Op Code
STA	4	1	Op Code Address + 1	1	0	1	1	1	Destination Address (MSB)
		2	Op Code Address + 2	1	0	1	1	1	Destination Address (LSB)
		3	Destination Address	0	1	0	1	1	Accumulator Data
		4	Op Code Address + 3	1	0	1	0	0	Next Op Code
ADD CPX LDD LDS LDX SUBD	5	1	Op Code Address + 1	1	0	1	1	1	Address of Operand (MSB)
		2	Op Code Address + 2	1	0	1	1	1	Address of Operand (LSB)
		3	Address of Operand	1	0	1	1	1	Operand Data (MSB)
		4	Address of Operand + 1	1	0	1	1	1	Operand Data (LSB)
		5	Op Code Address + 3	1	0	1	0	0	Next Op Code
STD STS STX	5	1	Op Code Address + 1	1	0	1	1	1	Destination Address (MSB)
		2	Op Code Address + 2	1	0	1	1	1	Destination Address (LSB)
		3	Destination Address	0	1	0	1	1	Register Data (MSB)
		4	Destination Address + 1	0	1	0	1	1	Register Data (LSB)
		5	Op Code Address + 3	1	0	1	0	0	Next Op Code
JSR	6	1	Op Code Address + 1	1	0	1	1	1	Jump Address (MSB)
		2	Op Code Address + 2	1	0	1	1	1	Jump Address (LSB)
		3	FFFF	1	1	1	1	1	Restart Address (LSB)
		4	Stack Pointer	0	1	0	1	1	Return Address (LSB)
		5	Stack Pointer - 1	0	1	0	1	1	Return Address (MSB)
		6	Jump Address	1	0	1	0	0	First Subroutine Op Code
ASL ASR COM DEC INC LSR NEG ROL ROR	6	1	Op Code Address + 1	1	0	1	1	1	Address of Operand (MSB)
		2	Op Code Address + 2	1	0	1	1	1	Address of Operand (LSB)
		3	Address of Operand	1	0	1	1	1	Operand Data
		4	FFFF	1	1	1	1	1	Restart Address (LSB)
		5	Address of Operand	0	1	0	1	1	New Operand Data
		6	Op Code Address + 3	1	0	1	0	0	Next Op Code
CLR	5	1	Op Code Address + 1	1	0	1	1	1	Address of Operand (MSB)
		2	Op Code Address + 2	1	0	1	1	1	Address of Operand (LSB)
		3	Address of Operand	1	0	1	1	1	Operand Data
		4	Address of Operand	0	1	0	1	1	00
		5	Op Code Address + 3	1	0	1	0	0	Next Op Code

(Continued)

2



HD6303X, HD63A03X, HD63B03X

Address Mode & Instructions		Cycles	Cycle #	Address Bus	R/W	RD	WR	LIR	Data Bus
IMPLIED									
ABA	ABX	1	1	Op Code Address + 1	1	0	1	0	Next Op Code
ASL	ASLD								
ASR	CBA								
CLC	CLI								
CLR	CLV								
COM	DEC								
DES	DEX								
INC	INS								
INX	LSR								
LSRD	ROL								
ROR	NOP								
SBA	SEC								
SEI	SEV								
TAB	TAP								
TBA	TPA								
TST	TSX								
TXS									
DAA	XGDX	2	1	Op Code Address + 1	1	0	1	0	Next Op Code
			2	FFFF	1	1	1	1	Restart Address (LSB)
PULA	PULB	3	1	Op Code Address + 1	1	0	1	0	Next Op Code
			2	FFFF	1	1	1	1	Restart Address (LSB)
			3	Stack Pointer + 1	1	0	1	1	Data from Stack
PSHA	PSHB	4	1	Op Code Address + 1	1	0	1	1	Next Op Code
			2	FFFF	1	1	1	1	Restart Address (LSB)
			3	Stack Pointer	0	1	0	1	Accumulator Data
			4	Op Code Address + 1	1	0	1	0	Next Op Code
PULX		4	1	Op Code Address + 1	1	0	1	0	Next Op Code
			2	FFFF	1	1	1	1	Restart Address (LSB)
			3	Stack Pointer + 1	1	0	1	1	Data from Stack (MSB)
			4	Stack Pointer + 2	1	0	1	1	Data from Stack (LSB)
PSHX		5	1	Op Code Address + 1	1	0	1	1	Next Op Code
			2	FFFF	1	1	1	1	Restart Address (LSB)
			3	Stack Pointer	0	1	0	1	Index Register (LSB)
			4	Stack Pointer - 1	0	1	0	1	Index Register (MSB)
			5	Op Code Address + 1	1	0	1	0	Next Op Code
RTS		5	1	Op Code Address + 1	1	0	1	1	Next Op Code
			2	FFFF	1	1	1	1	Restart Address (LSB)
			3	Stack Pointer + 1	1	0	1	1	Return Address (MSB)
			4	Stack Pointer + 2	1	0	1	1	Return Address (LSB)
			5	Return Address	1	0	1	0	First Op Code of Return Routine
MUL		7	1	Op Code Address + 1	1	0	1	0	Next Op Code
			2	FFFF	1	1	1	1	Restart Address (LSB)
			3	FFFF	1	1	1	1	Restart Address (LSB)
			4	FFFF	1	1	1	1	Restart Address (LSB)
			5	FFFF	1	1	1	1	Restart Address (LSB)
			6	FFFF	1	1	1	1	Restart Address (LSB)
			7	FFFF	1	1	1	1	Restart Address (LSB)

(Continued)



HD6303X, HD63A03X, HD63B03X

Address Mode & Instructions	Cycles	Cycle #	Address Bus	R	W	RD	WR	LIR	Data Bus
IMPLIED									
WAI	9	1	Op Code Address + 1	1	0	1	1	1	Next Op Code
		2	FFFF	1	1	1	1	1	Restart Address (LSB)
		3	Stack Pointer	0	1	0	1	1	Return Address (LSB)
		4	Stack Pointer - 1	0	1	0	1	1	Return Address (MSB)
		5	Stack Pointer - 2	0	1	0	1	1	Index Register (LSB)
		6	Stack Pointer - 3	0	1	0	1	1	Index Register (MSB)
		7	Stack Pointer - 4	0	1	0	1	1	Accumulator A
		8	Stack Pointer - 5	0	1	0	1	1	Accumulator B
		9	Stack Pointer - 6	0	1	0	1	1	Conditional Code Register
RTI	10	1	Op Code Address + 1	1	0	1	1	1	Next Op Code
		2	FFFF	1	1	1	1	1	Restart Address (LSB)
		3	Stack Pointer + 1	1	0	1	1	1	Conditional Code Register
		4	Stack Pointer + 2	1	0	1	1	1	Accumulator B
		5	Stack Pointer + 3	1	0	1	1	1	Accumulator A
		6	Stack Pointer + 4	1	0	1	1	1	Index Register (MSB)
		7	Stack Pointer + 5	1	0	1	1	1	Index Register (LSB)
		8	Stack Pointer + 6	1	0	1	1	1	Return Address (MSB)
		9	Stack Pointer + 7	1	0	1	1	1	Return Address (LSB)
		10	Return Address	1	0	1	0	0	First Op Code of Return Routine
SWI	12	1	Op Code Address + 1	1	0	1	1	1	Next Op Code
		2	FFFF	1	1	1	1	1	Restart Address (LSB)
		3	Stack Pointer	0	1	0	1	1	Return Address (LSB)
		4	Stack Pointer - 1	0	1	0	1	1	Return Address (MSB)
		5	Stack Pointer - 2	0	1	0	1	1	Index Register (LSB)
		6	Stack Pointer - 3	0	1	0	1	1	Index Register (MSB)
		7	Stack Pointer - 4	0	1	0	1	1	Accumulator A
		8	Stack Pointer - 5	0	1	0	1	1	Accumulator B
		9	Stack Pointer - 6	0	1	0	1	1	Conditional Code Register
		10	Vector Address FFFA	1	0	1	1	1	Address of SWI Routine (MSB)
		11	Vector Address FFFB	1	0	1	1	1	Address of SWI Routine (LSB)
		12	Address of SWI Routine	1	0	1	0	0	First Op Code of SWI Routine
SLP	4	1	Op Code Address + 1	1	0	1	1	1	Next Op Code
		2	FFFF	1	1	1	1	1	Restart Address (LSB)
		3	FFFF	1	1	1	1	1	Restart Address (LSB)
		4	Op Code Address + 1	1	0	1	0	0	Next Op Code
RELATIVE									
BCC	BCS	3	1	Op Code Address + 1	1	0	1	1	Branch Offset
BEQ	BGE		2	FFFF	1	1	1	1	Restart Address (LSB)
BGT	BHI		3	: Branch Address Test = "1" ! Op Code Address + 1 : Test = "0"	1	0	1	0	First Op Code of Branch Routine
BLE	BLS							Next Op Code	
BLT	BMT								
BNE	BPL								
BRA	BRN								
BVC	BVS								
BSR	5	1	Op Code Address + 1	1	0	1	1	1	Offset
		2	FFFF	1	1	1	1	1	Restart Address (LSB)
		3	Stack Pointer	0	1	0	1	1	Return Address (LSB)
		4	Stack Pointer - 1	0	1	0	1	1	Return Address (MSB)
		5	Branch Address	1	0	1	0	0	First Op Code of Subroutine

2



HD6303X, HD63A03X, HD63B03X

■ WARNING CONCERNING THE BOARD DESIGN OF OSCILLATION CIRCUIT

When designing a board, note that crosstalk may disturb the normal oscillation if signal lines are placed near the oscillation circuit as shown in Figure 26. Place the crystal and C_L as close to the HD6303X as possible.

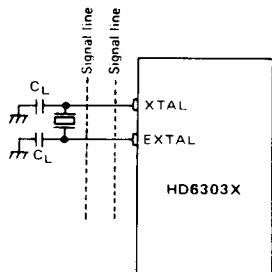

Do not use this kind of printed-circuit board design.

Figure 26 Warning concerning board design of oscillation circuit

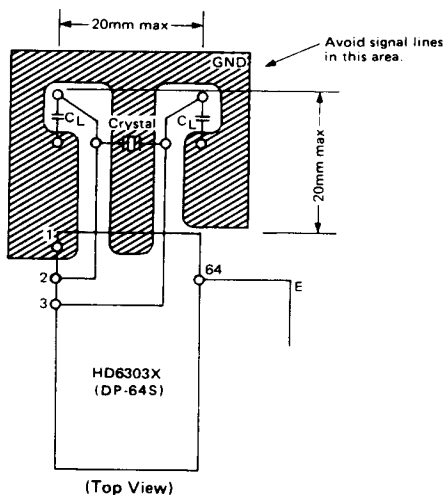

Figure 27 Example of Oscillation Circuits in Board Design

■ RECEIVE MARGIN OF THE SCI

Receive margin of the SCI contained in the HD6303X is shown in Table 17.

Note: SCI = Serial Communication Interface

	Bit distortion tolerance ($t-t_0$)/ t_0	Character distortion tolerance ($T-T_0$)/ T_0
HD6303X	±43.7%	±4.37%

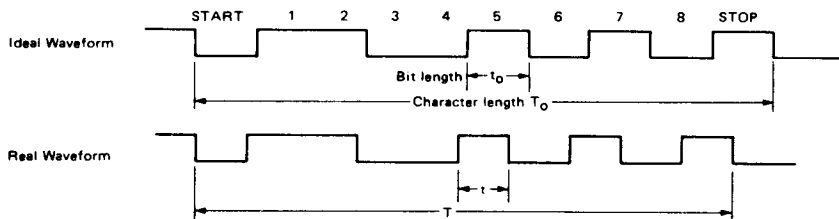

■ WARNING CONCERNING WAI INSTRUCTION

If the HALT signal is accepted by the MCU while the WAI instruction is executing, the CPU will not operate correctly after HALT mode is canceled.

WAI is an instruction which waits for an interrupt. The corresponding interrupt routine is executed after an interrupt occurs.

However, during the execution of the WAI instruction, HALT input makes the CPU malfunction and fetch an abnormal interrupt vectoring address.

In HALT mode, the CPU operates correctly without the WAI instruction, and WAI is executed correctly without HALT input. Therefore, if HALT input is necessary, make interrupts wait during the loop routine, as shown in Figure 28.

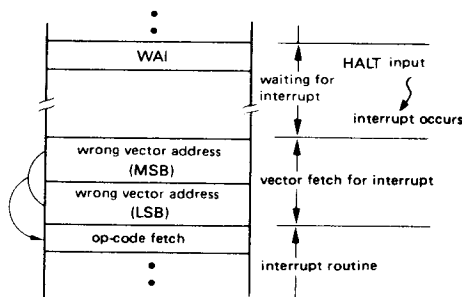

Figure 28 MAC function during WAI



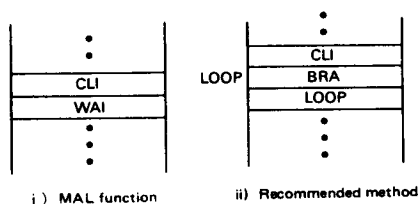

Figure 29 Program to wait for interrupt

■ **WRITE-ONLY REGISTER**

When the CPU reads a write-only register, the read data is always \$FF, regardless of the value in the write-only register. Therefore, be careful of the results of instructions which read write-only register and perform an arithmetic or logical operation on its contents, such as AIM, ADD, or ROL, is executed, because the arithmetic or logical operation is always done with the data \$FF. In particular, don't use the AIM, OIM or EIM instruction to manipulate the DDR bit of PORT.

■ **WARNING CONCERNING POWER START-UP**

$\overline{\text{RES}}$ must be held low for at least 20 ms when the power starts up. In this case, the internal reset function is not effective until the oscillation begins at power-on. The $\overline{\text{RES}}$ signal is input to the LSI in synchronism with the internal clock ϕ (shown in Figure 30.)

Therefore, after power starts up, the LSI conditions such as its I/O ports and operating mode, are unstable. Fix the level of I/O ports by means of an external circuit to determine the level for system operation during the oscillator stabilization time.

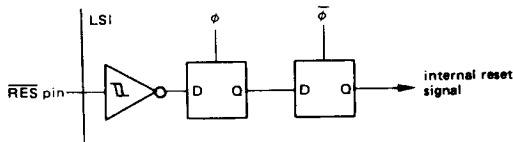

Figure 30 $\overline{\text{RES}}$ circuit

