



GaAs Beam Lead Schottky Barrier Diodes

Technical Data

HSCH-9101
HSCH-9201
HSCH-9251

Features

- **Gold Tri-Metal System**
For Improved Reliability
- **Low Capacitance**
- **Low Series Resistance**
- **High Cutoff Frequency**
- **Polyimide Passivation**
- **Multiple Configurations**

Description

The HSCH-9101 single, the HSCH-9201 series pair, and the HSCH-9251 anti-parallel pair are advanced gallium arsenide Schottky barrier diodes. These devices are fabricated utilizing molecular beam epitaxy (MBE) manufacturing techniques and feature rugged construction and consistent electrical performance. A polyimide coating provides scratch protection and resistance to contamination.

HSCH-9101

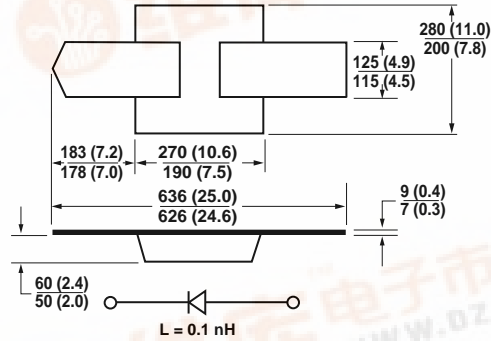

HSCH-9201

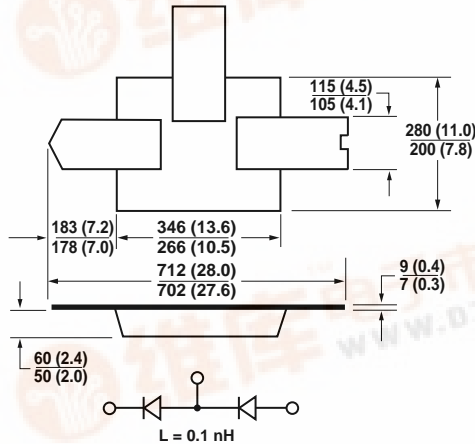

HSCH-9251

Junction Side Up

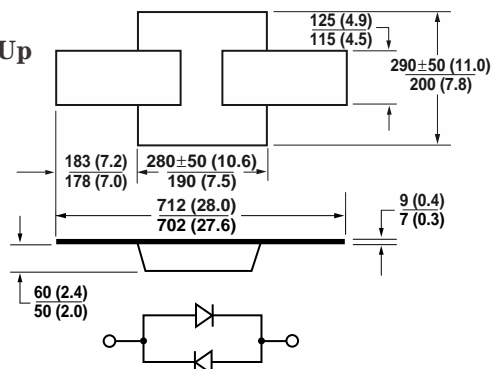

Applications

This line of Schottky diodes is optimized for use in mixer applications at millimeter wave frequencies. Some suggested mixer types are single ended and single balanced for the single and series pair. The anti-parallel pair is ideal for harmonic mixers.

Thermocompression bonding is recommended. Welding or conductive epoxy may also be used. For additional information see Application Note 979, "The Handling and Bonding of Beam Lead Devices Made Easy," or Application Note 992, "Beam Lead Attachment Methods," or

Application Note 993, "Beam Lead Device Bonding to Soft Substrates."

GaAs diodes are ESD sensitive. Proper precautions should be used when handling these devices.

Assembly Techniques

Maximum Ratings

Power Dissipation at $T_{LEAD} = 25^{\circ}\text{C}$ 75 mW per junction
*Measured in an infinite heat sink derated linearly
to zero at maximum rated temperature*

Operating Temperature -65°C to $+150^{\circ}\text{C}$
Storage Temperature -65°C to $+150^{\circ}\text{C}$
Mounting Temperature 235°C for 10 seconds
Minimum Lead Strength 6 grams

Electrical Specifications at $T_A = 25^{\circ}\text{C}$

Part Number			HSCH-9101			HSCH-9201			HSCH-9251		
Symbol	Parameters and Test Conditions	Units	Min.	Typ.	Max.	Min.	Typ.	Max.	Min.	Typ.	Max.
$C_j^{[1]}$	Junction Capacitance $V_R = 0\text{ V}, f = 1\text{ MHz}$	pF		0.040	0.050		0.040	0.050		0.040	
$\Delta C_j^{[1]}$	Junction Capacitance Difference $V_R = 0\text{ V}, f = 1\text{ MHz}$	pF					0.005	0.010			
$R_S^{[2]}$	Series Resistance	Ω			6			6			6
V_{F1}	Forward Voltage $I_F = 1\text{ mA}$	mV		700	800		700	800		700	800
V_{F10}	Forward Voltage $I_F = 10\text{ mA}$	mV		800	850		800	850		800	850
ΔV_F	Forward Voltage Difference $I_F = 1\text{ mA}$ and 10 mA	mV						15			15
V_{BR}	Reverse Breakdown Voltage $V_R = V_{BR}$ measure $I_R \leq 10\ \mu\text{A}$ (per junction)	V	4.5			4.5					

Notes:

1. Junction capacitance is determined by measuring total device capacitance and subtracting the calculated parasitic capacitance (0.035 pF).
2. Series resistance is determined by measuring the dynamic resistance and subtracting the calculated junction resistance of 6 Ω .



Typical Parameters

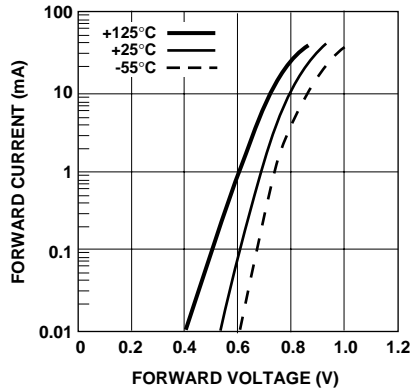

Figure 1. Typical Forward Characteristics for HSCH-9101, HSCH-9201, and HSCH-9251.

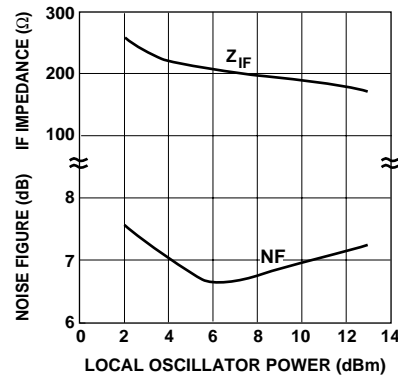

Figure 2. Typical Noise Figure and I.F. Impedance vs. Local Oscillator Power, for HSCH-9101 and HSCH-9201.

SPICE Parameters

Parameter	Units	HSCH-9XXX
B_V	V	5
C_{J0}	pF	0.04
E_G	eV	1.43
I_{BV}	A	10E-5
I_S	A	1.6 x 10E-13
N		1.20
R_S	Ω	5
P_B	V	0.7
P_T		2
M		0.5

