



GM6608 7.5A PRECISION LINEAR REGULATORS

Power Management

Description

The GM6608 series of positive adjustable and fixed regulators are designed to provide 7.5A output with low dropout voltage performance. On-chip trimming adjusts the reference voltage to 2%. Put them to work in post regulators or microprocessor power supplies where low voltage operation and fast transient response are required.

The fast loop response and low dropout voltage make this regulator ideal for applications where low voltage operation and good transient response are important.

The GM6608's are available in TO-220 and surfacemount TO263 packages.

Features

- ◆ Adjustable or Fixed Output
- ◆ Output Current of 7.5A
- ◆ Dropout Voltage (typical) 1.2V @ 7.5A
- ◆ Typical Line Regulation 0.2%
- ◆ Typical Load Regulation 0.4%
- ◆ Fast Transient Response
- ◆ Current Limit Protection
- ◆ Thermal Shutdown Protection

Application

PC Motherboards

Post Regulators for Switching Supplies

Microcontroller Systems

Low power Microprocessor Systems

TYPICAL APPLICATION CIRCUITS

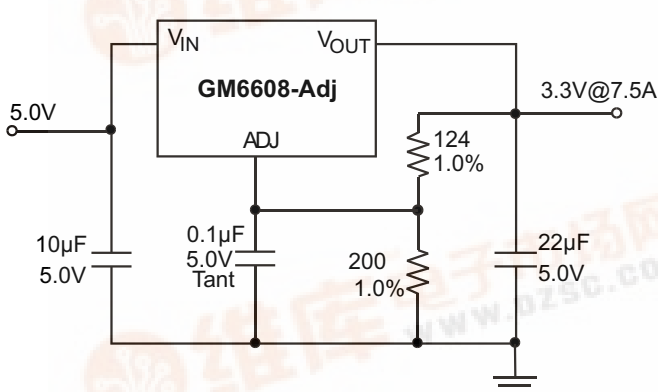

(Adjustable Version)

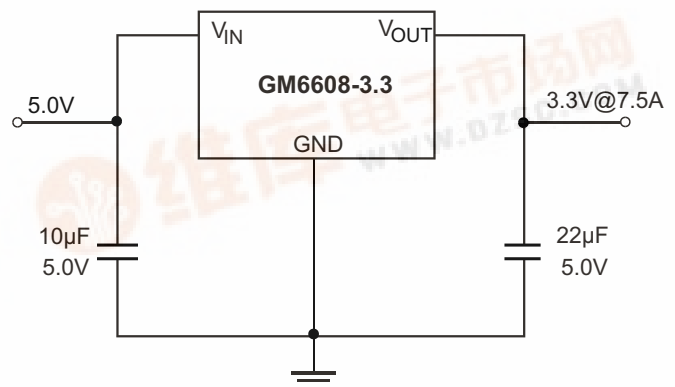

(Fixed Version)



◆ MARKING INFORMATION & PIN CONFIGURATIONS (Top View)

TO-220

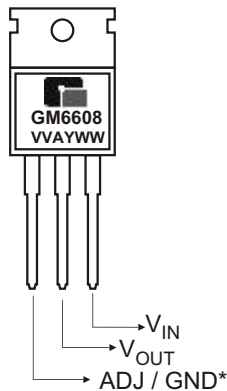

TO-263-2 (D²PAK)

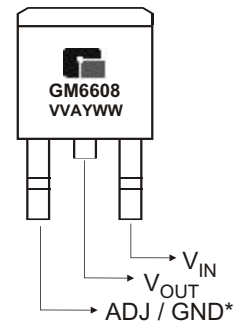

V V = Output Voltage (50 = 5.0V, A =Adj)
 A = Assembly Location
 Y = Year
 W W = Work Week

* On fixed versions Pin 1 = GND,
 on adjustable versions Pin 1 = ADJ
 * Tab = V_{OUT}

◆ ORDERING INFORMATION

Ordering Number	Output Voltage	Package	Shipping
GM6608-ATA3T	Adj	TO-263-2	50 Units / Tube
GM6608-ATA3R	Adj	TO-263-2	800 Units / Tape & Reel
GM6608-ATB3T	Adj	TO-220	50 Units / Tube
GM6608-2.5TA3T	2.5	TO-263-2	50 Units / Tube
GM6608-2.5TA3R	2.5	TO-263-2	800 Units / Tape & Reel
GM6608-2.5TB3T	2.5	TO-220	50 Units / Tube
GM6608-3.3TA3T	3.3	TO-263-2	50 Units / Tube
GM6608-3.3TA3R	3.3	TO-263-2	800 Units / Tape & Reel
GM6608-3.3TB3T	3.3	TO-220	50 Units / Tube

* For detail Ordering Number identification, please see last page.



◆ ABSOLUTE MAXIMUM RATINGS

PARAMETER	SYMBOL	VALUE	UNIT
Power Dissipation	P_D	Internally limited	W
Input Supply Voltage	V_{IN}	7.0	V
Junction Temperature	T_J	+150	°C
Lead Temperature(Soldering, 10sec)	T_{LEAD}	300	°C
Operating Junction Temperature Range	T_J	-40 to + 125	°C
Storage Temperature Range	T_{STG}	-65 to + 150	°C
ESD Damage Threshold	ESD	2.0	KV

◆ BLOCK DIAGRAM

(Fixed Version)

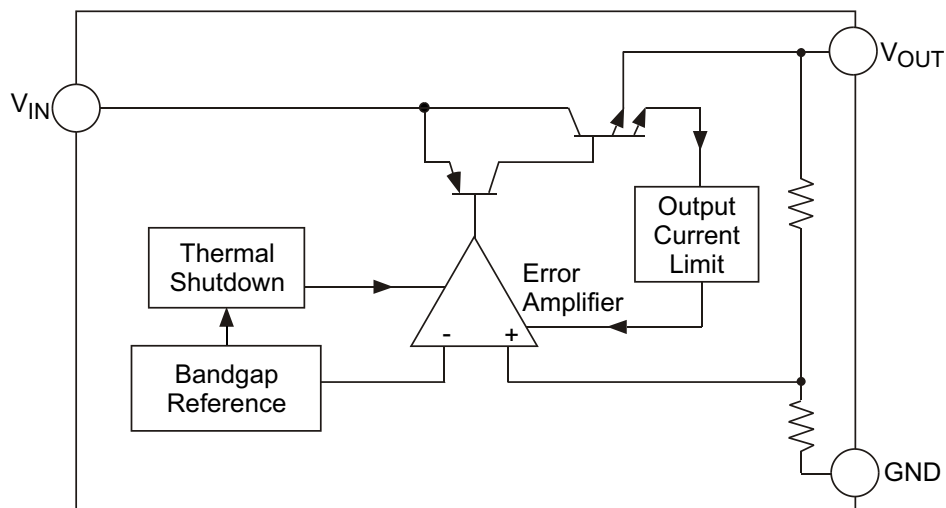

(Adjustable Version)

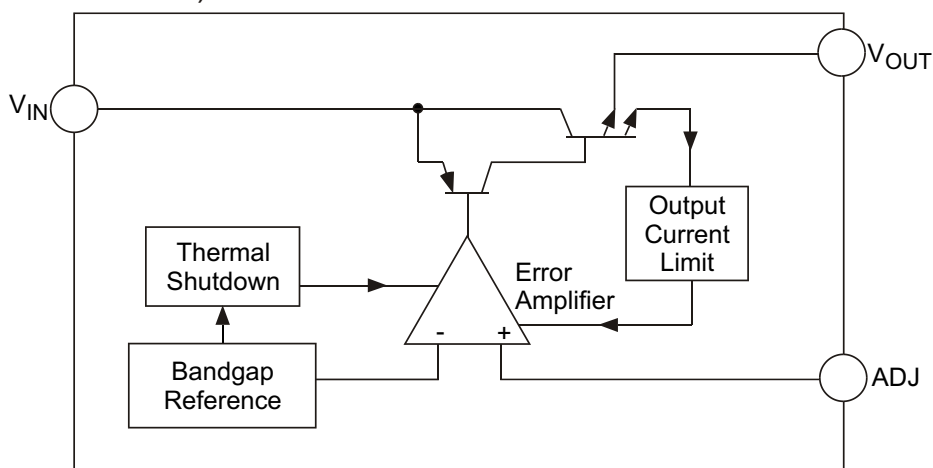

◆ ELECTRICAL CHARACTERISTICS

Unless otherwise specified: Adjustable Option: $V_{IN} = 2.65V$ to $7.0V$ and $I_O = 10mA$ to I_{RATED} . Fixed Options:
 $I_O = 0mA$ to I_{RATED} , $V_{IN} (2.5V) = 3.9V$ to $7.0V$, $V_{IN} (2.85V) = 4.25V$ to $7.0V$, $V_{IN} (3.3V) = 4.75V$ to $7.0V$.

Parameter	Symbol	V_{IN}	I_O	$T_J^{(5)}$	Min	Typ	Max	Unit
Output Voltage ⁽¹⁾ (Fixed Versions)	V_O	$V_O + 5V$	10mA	25°C	-1%	V_O	+1%	V
		$V_O + 5V$	10mA~8A	O.T.	-2%		+2%	
Reference Voltage ⁽¹⁾ (Adjustable Voltage)	V_{REF}	5V	10mA	25°C	1.238	1.250	1.262	V
				O.T.	1.230		1.270	
Line Regulation ⁽¹⁾	$REG_{(LINE)}$	$V_{OUT} + 1.5V$	10mA	O.T.	-	0.035	0.20	%
Load Regulation ⁽¹⁾	$REG_{(LOAD)}$	$V_{OUT} + 0.8V$		O.T.	-	0.20	0.40	%
Dropout Voltage ⁽¹⁾⁽²⁾	V_D		7.5A	O.T.	-	1.2	1.4	V
Current Limit	I_{CL}			O.T.	7.5	9.5	-	A
Quiscent Current (fixed version)	I_Q			O.T.	-	12	14	mA
Temperature Coefficient	T_C			O.T.	-	0.005	-	%/°C
Adjust Pin Current	I_{ADJ}			O.T.	-	55	90	μA
Adjust Pin Current Change	I_{ADJ}			O.T.	-	0.20	5	μA
Temperature Stability	T_S	5V	0.5A	O.T.	-	0.50	-	%
Minimum Load Current (Adj. Version)	I_O	5V		O.T.	-	5	10	mA
RMS Output Noise ⁽³⁾	V_N			25°C	-	0.003	-	%/ V_O
Ripple Rejection Ration ⁽⁴⁾	R_A	5V	7.5A	O.T.	60	80	-	dB

NOTES:

- (1) Low duty cycle pulse testing with Kelvin connections required
- (2) V_{OUT} , $V_{REF} = 1\%$
- (3) Bandwidth of 10Hz to 10kHz
- (4) 120Hz input ripple (C_{ADJ} for ADJ = 25μF)
- (5) O.T. = overspecified operating junction temperature range



◆ APPLICATION INFORMATION

The GM6608 series linear regulators provide fixed and adjustable output voltages at currents up to 7.5A. These regulators are protected against overcurrent conditions and include thermal shutdown protection. The GM6608's have a composite PNP-NPN output transistor and require an output capacitor for stability.

A detailed procedure for selecting this capacitor follows.

Stability Considerations

The output compensation capacitor helps to determine three main characteristics of a linear regulator's performance: start-up delay, load transient response, and loop stability. The capacitor value and type is based on cost, availability, size and temperature constraints. A tantalum or aluminum electrolytic capacitor is preferred, as a film or ceramic capacitor with almost zero ESR can cause instability. An aluminum electrolytic capacitor is the least expensive type, but when the circuit operates at low temperatures, both the value and ESR of the capacitor will vary widely. For optimum performance over the full operating temperature range, a tantalum capacitor is best. A 22 μ F tantalum capacitor will work fine in most applications, but with high current regulators such as the GM6608 higher capacitance values will improve the transient response and stability. Most applications for the GM6608's involve large changes in load current, so the output capacitor must supply instantaneous load current. The ESR of the output capacitor causes an immediate drop in output voltage given by:

$$V = I \times \text{ESD}$$

In microprocessor applications an output capacitor network of several tantalum and ceramic capacitors in parallel is commonly used. This reduces overall ESR and minimizes the instantaneous output voltage drop under transient load conditions. The output capacitor network should be placed as close to the load as possible for the best results

Protection Diodes

When large external capacitors are used with most linear regulator it is wise to add protection diodes. If the input voltage of the regulator is shorted, the output capacitor will discharge into the output of the regulator. The discharge current depends on the value of capacitor, output voltage and rate at which V_{IN} drops.

Figure 1 ^{(a),(b)} Protection Diode Scheme for Large Output Capacitors

(a) Fixed Version

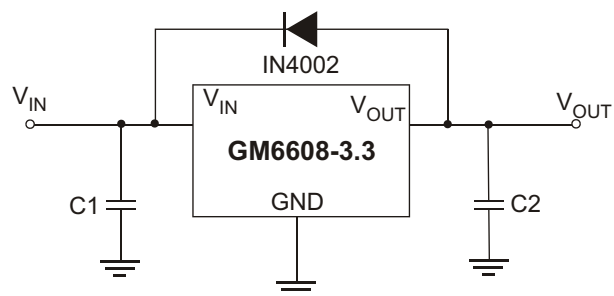

(b) Adjustable Version

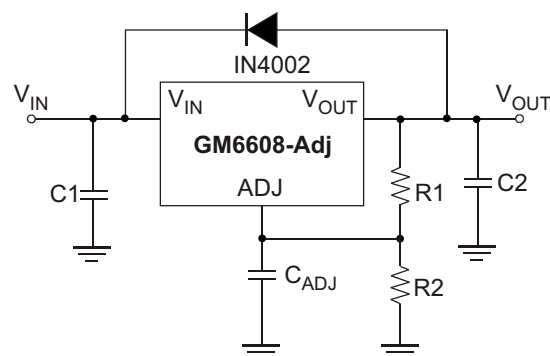

In the GM6608 linear regulators, the discharge path is through a large junction, and protection diodes are normally not needed. However, if the regulator is used with large output capacitance values and the input voltage is instantaneously shorted to ground, damage can occur. In this case, a diode connected as shown above in Figure 1.

Output Voltage Sensing

The GM6608 series are three terminal regulators, so they cannot provide true remote load sensing. Load regulation is limited by the resistance of the conductors connecting the regulator to the load. For best results the GM6608 should be connected as shown in Figure 2.

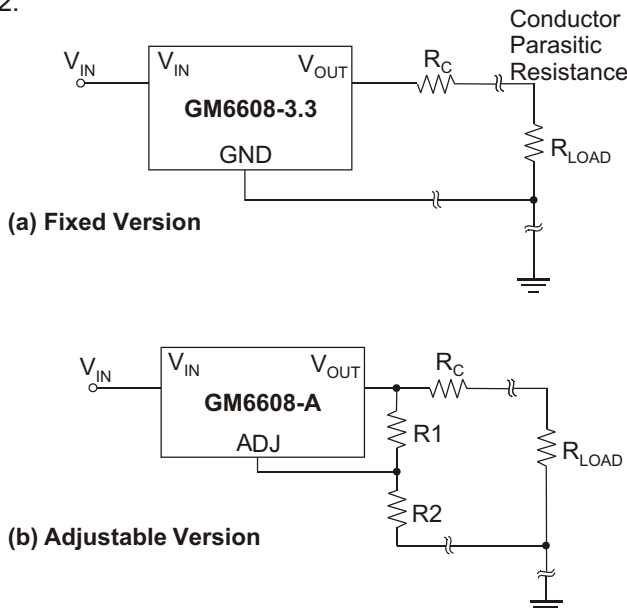

Figure 2 (a),(b) Conductor Parasitic Resistance Effects are Minimized by this Grounding Scheme For Fixed and Adjustable Output Regulators

Calculating Power Dissipation and Heat Sink Requirements

The GM6608 series precision linear regulators include thermal shutdown and current limit circuitry to protect the devices. However, high power regulators normally operate at high junction temperatures so it is important to calculate the power dissipation and junction temperatures accurately to be sure that you use an adequate heat sink. The case is connected to \$V_{OUT}\$ on the GM6608, so electrical isolation may be required for some applications. Thermal compound should always be used with high current regulators like the GM6608.

The thermal characteristics of an IC depend on four factors:

1. Maximum Ambient Temperature \$T_A\$ (°C)
2. Power Dissipation \$P_D\$ (Watts)
3. Maximum Junction Temperature \$T_J\$ (°C)
4. Thermal Resistance Junction to ambient \$R_{JA}\$ (°C/W)

This relationship of these four factors is expressed by equation (1):

$$T_J = T_A + P_D \times R_{JA} \dots\dots(1)$$

Maximum ambient temperature and power dissipation are determined by the design while the maximum junction temperature and thermal resistance depend on the manufacturer and the package type.

The maximum power dissipation for a regulator is expressed by equation (2):

$$P_{D(max)} = \{ V_{IN(max)} - V_{OUT(min)} \} I_{OUT(max)} + V_{IN(max)} I_Q \dots\dots(2)$$

where:
 \$V_{IN(max)}\$ is the maximum input voltage,
 \$V_{OUT(min)}\$ is the minimum output voltage,
 \$I_{OUT(max)}\$ is the maximum output current
 \$I_Q\$ is the maximum quiescent current at \$I_{OUT(max)}\$.

A heat sink effectively increases the surface area of the package to improve the flow of heat away from the IC into the air. Each material in the heat flow path between the IC and the environment has a thermal resistance. Like series electrical resistances, these resistances are summed to determine \$R_{JA}\$, the total thermal resistance between the junction and the air. This is expressed by equation (3):

$$R_{JA} = R_{JC} + R_{CS} + R_{SA} \dots\dots(3)$$

Where all of the following are in °C/W:
 \$R_{JC}\$ is thermal resistance of junction to case,
 \$R_{CS}\$ is thermal resistance of case to heat sink,
 \$R_{SA}\$ is thermal resistance of heat sink to ambient air

The value for \$R_{JA}\$ is calculated using equation (3) and the result can be substituted in equation (1). The value for \$R_{JC}\$ is 3.5°C/W for a given package type based on an average die size. For a high current regulator such as the GM6608 the majority of the heat is generated in the power transistor section.



◆ Typical Performance Characteristics

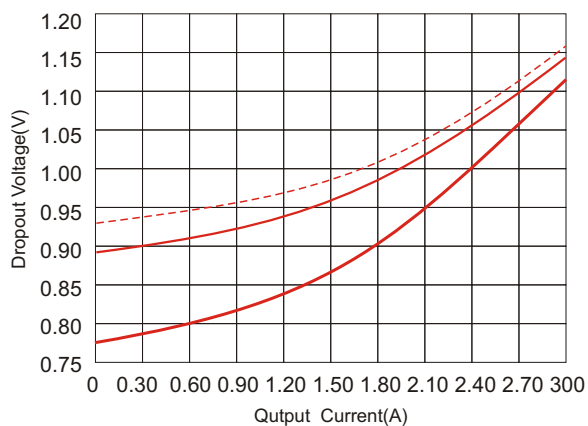

Figure 3. Dropout Voltage vs. Output Current

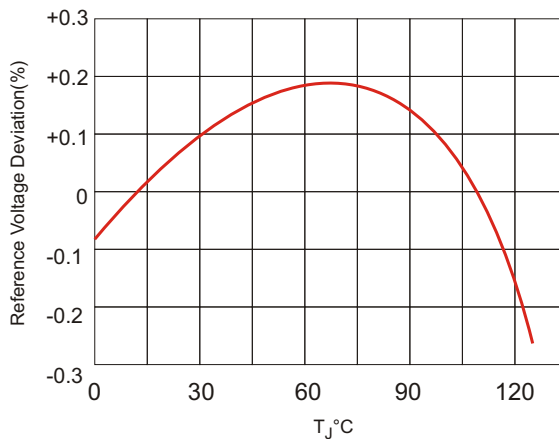

Figure 4. Bandgap Reference Voltage Deviation vs. Temperature

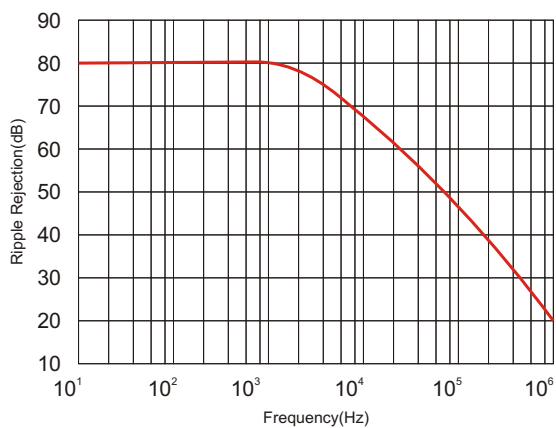

Figure 5. Ripple Rejection vs. Frequency

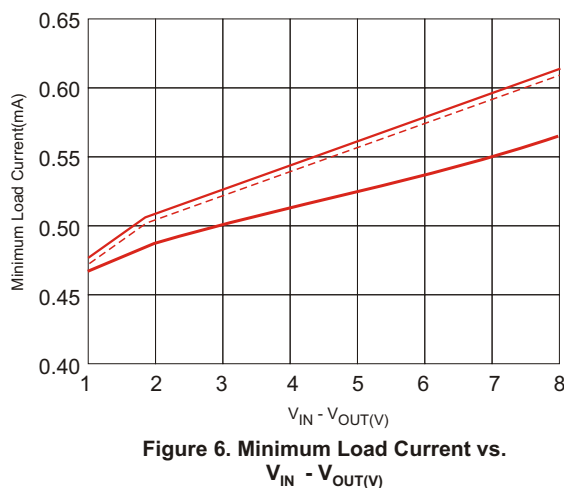
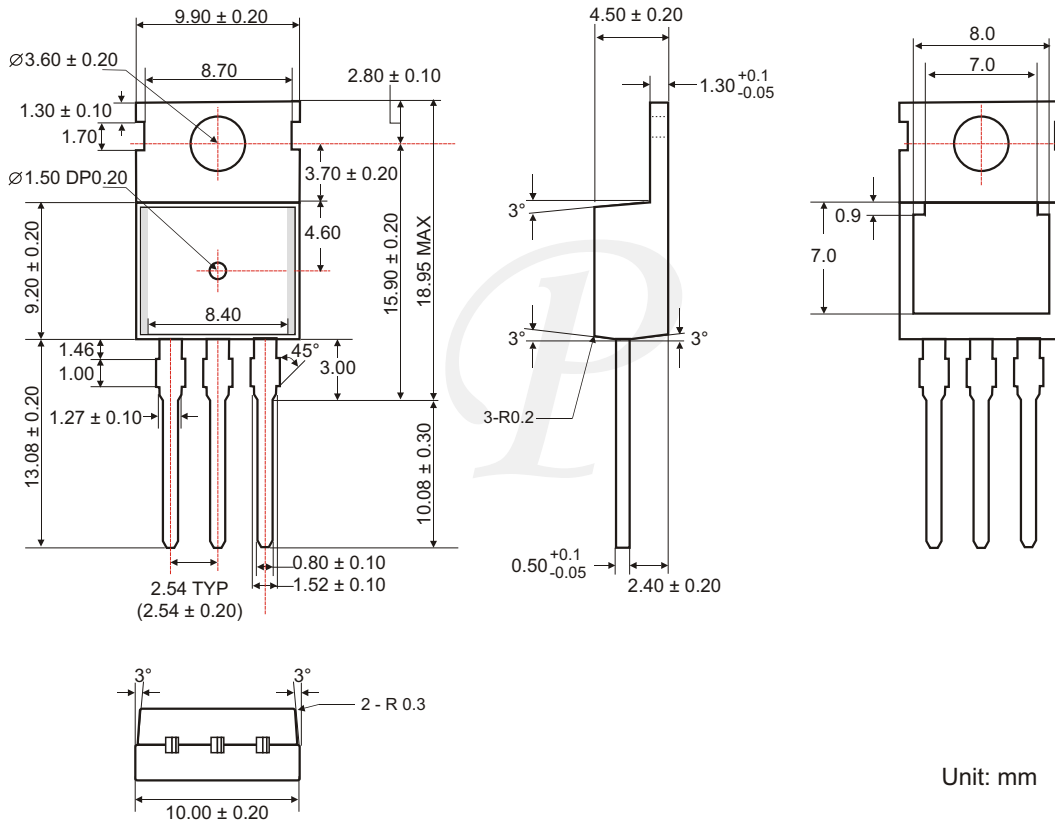

Figure 6. Minimum Load Current vs. V_{IN} - V_{OUT}



◆ TO-220 PACKAGE OUTLINE DIMENSIONS



◆ TO-263-2 PACKAGE OUTLINE DIMENSIONS

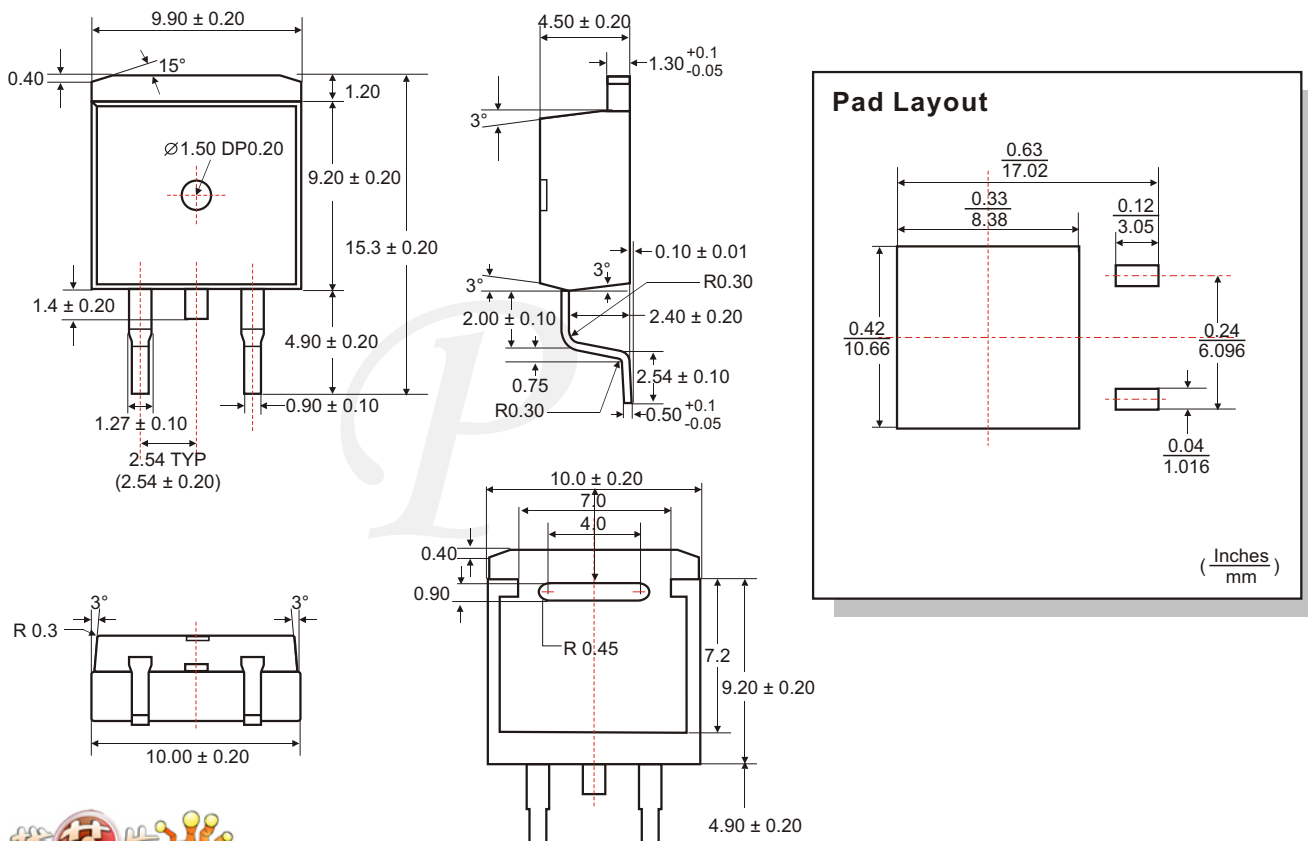

◆ ORDERING NUMBER

