



GM317 3- TERMINAL ADJUSTABLE REGULATOR

Power Management

Description

The GM317 is an adjustable 3-terminal positive voltage regulator capable of supplying in excess of 1.5 A over an output voltage range of 1.2 V to 37 V. This voltage regulator is exceptionally easy to use and requires only two external resistors to set the output voltage. Further, it employs internal current limiting, thermal shutdown and safe area compensation, making it essentially blow-out proof.

The GM317 serves a wide variety of applications including local, on card regulation. This device can also be used to make a programmable output regulator, or by connecting a fixed resistor between the adjustment and output, the GM317 can be used as a precision current regulator.

Features

- ◆ Output current up to 1.5A
- ◆ 3-Terminal Regulators
- ◆ Input Regulation typ. 0.01% per input
- ◆ Output Regulation typ. 0.1%
- ◆ Peak Output Current Constant over Temperature Range of Regulator
- ◆ Wide Range of Output Voltages 1.2V to 37V
- ◆ Available in TO-220 and TO-263 Packages
- ◆ Ripple Rejection Typically 80dB
- ◆ Direct replacements for LM317

TYPICAL APPLICATION

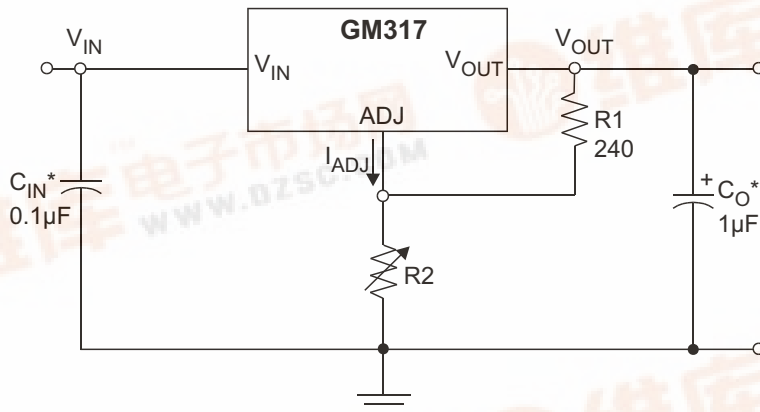

* C_{IN} is required if regulator is located an appreciable distance from power supply filter.

**C_O is not needed for stability, however, it improve transient response.

$$V_{OUT} = 1.25V \left(1 + \frac{R2}{R1}\right) + I_{ADJ}R2$$

Since I_{ADJ} is controlled to less than 100µA, the error associated with this term is negligible in most applications.



◆ **MARKING INFORMATION & PIN CONFIGURATIONS**

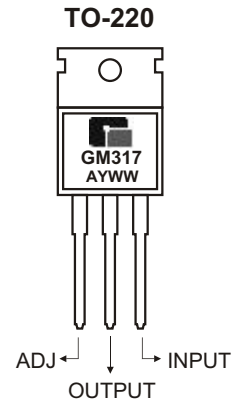
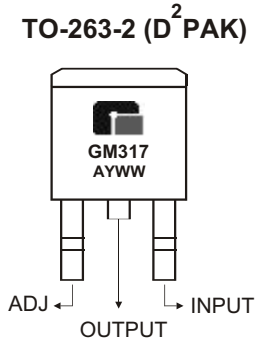

A : Assemble Location
 Y : Year
 W W : Work weeks

◆ **ORDERING INFORMATION**

Ordering Number	Package	Shipping
GM317TA3T	TO-263	50 Units / Tube
GM317TA3R	TO-263	800 Units / Tape & Reel
GM317TB3T	TO-220	50 Units / Tube

* For detail Ordering Number identification, please see last page.



◆ ABSOLUTE MAXIMUM RATINGS

PARAMETER	VALUE	UNIT
Input to Output Differential Voltage, $V_I - V_O$	40	V
Continuous Total Dissipation at 25°C free-air temperature	2	W
Continuous Total Dissipation at (or below) 25°C case temperature	15	
Operating free-air, case, or virtual junction Temperature Range	0 to +125	°C
Storage Temperature Range	-65 to +150	
Lead Temperature 1.6mm (1/16 inch) from case for 10 sec.	260	

◆ RECOMMENDED OPERATING CONDITIONS

PARAMETER	MIN	MAX	UNIT
Output Current, I_O	10	1500	mA
Operating virtual junction temperature, T_J	0	125	°C

◆ SCHEMATIC DIAGRAM

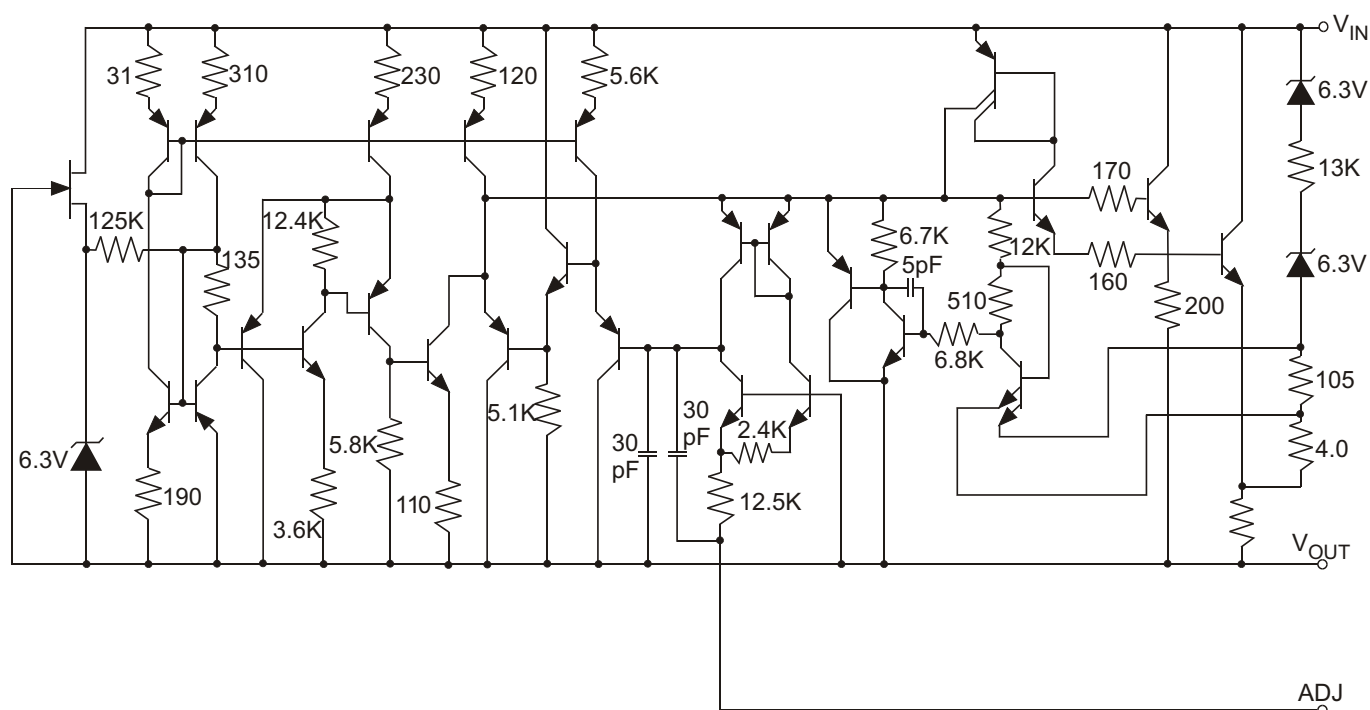

This device contains 29 active transistors.

◆ ELECTRICAL CHARACTERISTICS

over recommended ranges of operating virtual junction temperature, unless otherwise noted.

PARAMETER	TEST CONDITIONS*		Min	Typ	Max	Unit
Input Regulation (Note 2)	$V_I - V_O = 3V$ to $40V$ (Note 3)	$T_J = \text{MIN to MAX}$		0.01	0.04	% / V
		$I_O = 10\text{mA to } 1.5\text{A}$		0.02	0.07	
Ripple Rejection	$V_O = 10V, f = 120\text{Hz}$			65		dB
	$V_O = 10V, f = 120\text{Hz},$ $10\mu\text{F}$ capacitor between ADJ and ground		66	80		
Output Regulation	$I_O = 10\text{mA to } 1.5\text{A}$ $T_J = 25^\circ\text{C}$ (Note 3)	$V_O \leq 5V$		5	25	mV
		$V_O > 5V$		0.1	0.5	%
	$I_O = 10\text{mA to } 1.5\text{A}$ (Note 3)	$V_O \leq 5V$		20	70	mV
		$V_O > 5V$		0.3	1.5	%
Output Voltage Change with Temperature	$T_J = \text{MIN to MAX}$			1		%
Output Voltage Long-Term Drift (Note 4)	After 1000h at $T_J = \text{MAX}$ and $V_I - V_O = 40V$			0.3	1	%
Output Noise Voltage	$f = 10\text{Hz to } 10\text{kHz}, T_J = 25^\circ\text{C}$			0.003		%
Minimum Output Current to maintain Regulation	$V_I - V_O = 40V$			3.5	10	mA
Adjustment-Terminal Current				50	100	μA
Adjustment-Terminal Current Change	$V_I - V_O = 2.5V$ to $40V,$ $I_O = 10\text{mA to } 1.5\text{A}$			0.2	5.0	μA
Reference Voltage (Output to ADJ)	$V_I - V_O = 3V$ to $40V,$ $I_O = 10\text{mA to } 1.5\text{A}, P \leq 15W$		1.2	1.25	1.3	V
Peak Output Current	$V_I - V_O \leq 15V$		1.5	2.2		A
	$V_I - V_O \leq 40V, T_J = 25^\circ\text{C}$		0.15	0.4		

* Unless otherwise noted, these specifications apply for the following test conditions: $V_I - V_O = 5V$ and $I_O = 0.5A$.

For conditions shown as MIN or MAX, use the appropriate value specified under recommended operating conditions.

Note 1: All characteristics are measured with a $0.1\mu\text{F}$ capacitor across the input and a $1\mu\text{F}$ capacitor across the output.

Note 2: Input regulation is expressed here as the percentage change in output voltage per 1V change at the input.

Note 3: Pulse testing techniques are used to maintain the junction temperature as close to the ambient temperature as possible. Thermal effects must be taken into account separately.

Note 4: Since long-term drift cannot be measured on the individual devices prior to shipment, this specification is not intended to be a guarantee or warranty. It is an engineering estimate of the average drift to be expected from lot to lot.



◆ Typical Performance Characteristics

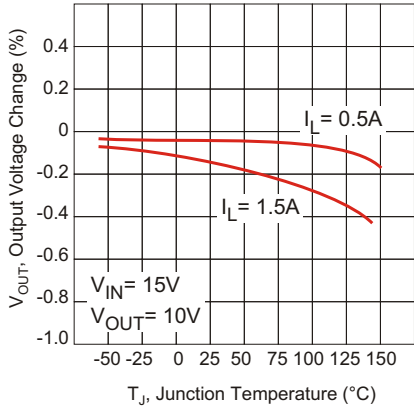

Figure 1. Load Regulation

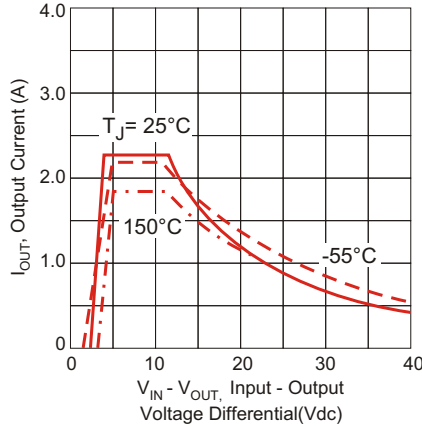

Figure 2. Current Limit

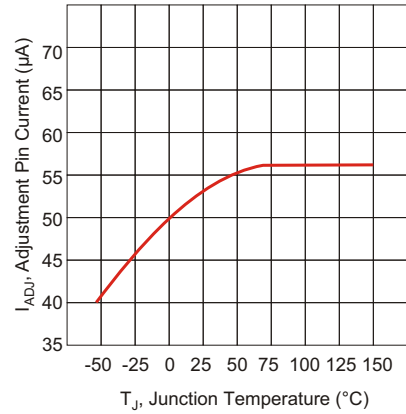

Figure 3. Adjustment Pin Current

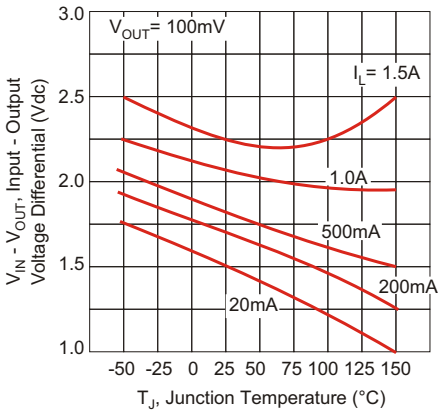

Figure 4. Dropout Voltage

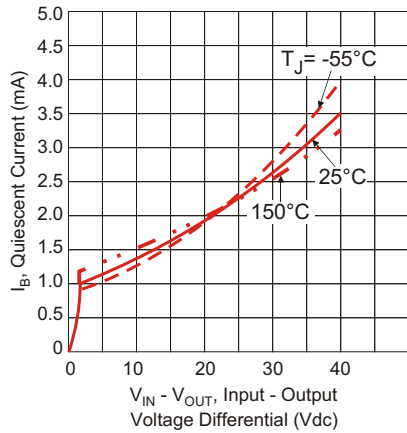

Figure 5. Minimum Operating Current

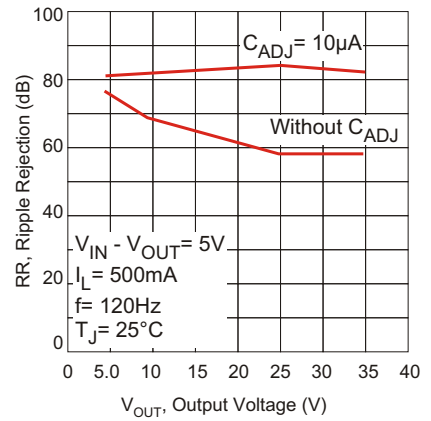

Figure 6. Ripple Rejection versus Output Voltage

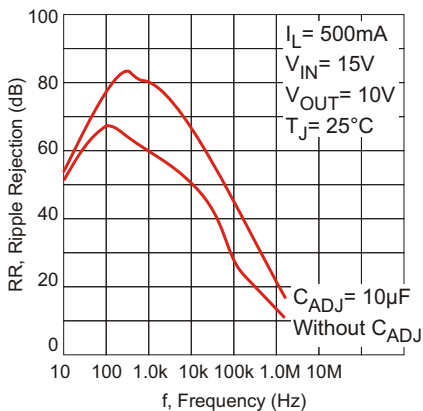

Figure 7. Ripple Rejection Versus Frequency



◆ APPLICATION INFORMATION

Basic Circuit Operation

The GM317 is a 3-terminal floating regulator. In operation, the GM317 develops and maintains a nominal 1.25V reference (V_{ref}) between its output and adjustment terminals. This reference voltage is converted to a programming current flows through R2 to ground.

The regulated output voltage is given by:

$$V_{OUT} = V_{ref} \left(1 + \frac{R_2}{R_1} \right) + I_{ADJ} R_2$$

Since the current from the adjustment terminal (I_{ADJ}) represents an error term in the equation, the GM317 was designed to control I_{ADJ} to less than 100µA and keep it constant. To do this, all quiescent operating current is returned to the output terminal. This imposes the requirement for a minimum load current. If the load current is less than this minimum, the output voltage will rise.

Since the GM317 is a floating regulator, it is only the voltage differential across the circuit which is important to performance, and operation at high voltages with respect to ground is possible.

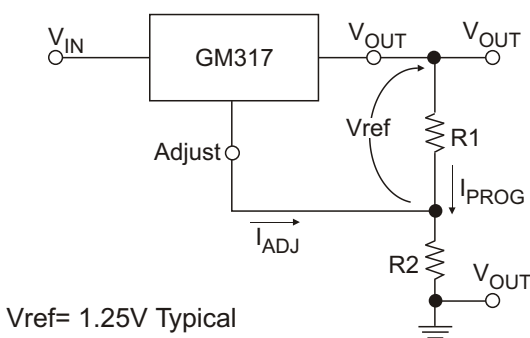

Figure 8. Basic Circuit Configuration

Load Regulation

The GM317 is capable of providing extremely good load regulation, but a few precautions are needed to obtain maximum performance. For best performance, the programming resistor (R1) should be connected as close to the regulator as possible to minimize line drops which effectively appear in series with the reference, thereby degrading regulation. The ground end of R2 can be returned near the load ground to provide remote ground sensing and improve load regulation.

External Capacitors

A 0.1µF disc or 1.0µF tantalum input bypass capacitor (C_{IN}) is recommended to reduce the sensitivity to input line impedance.

The adjustment terminal may be bypassed to ground to improve ripple rejection. This capacitor (C_{ADJ}) prevents ripple from being amplified as the output voltage is increased. A 10µF capacitor should improve ripple rejection about 15 dB at 120Hz in a 10V application.

Although the GM317 is stable with no output capacitance, like any feedback circuit, certain values of external capacitance can cause excessive ringing. An output capacitance (C_O) in the form of a 1.0µF tantalum or 25µF aluminum electrolytic capacitor on the output swamps this effect and insures stability.

Protection Diodes

When external capacitors are used with any IC regulator it is sometimes necessary to add protection diodes to prevent the capacitors from discharging through low current points into the regulator.

Figure 9. shows the GM317 with the recommended protection diodes for output for output voltage in excess of 25V or high capacitance values ($C_O > 25\mu F$, $C_{ADJ} > 10\mu F$). Diode D1 prevents C_O from discharging thru the IC during an input short circuit. Diode D2 protects against capacitor C_{ADJ} discharging through the IC during an output short circuit.

The combination of diodes D1 and D2 prevents C_{ADJ} from discharging through the IC during an input short circuit.

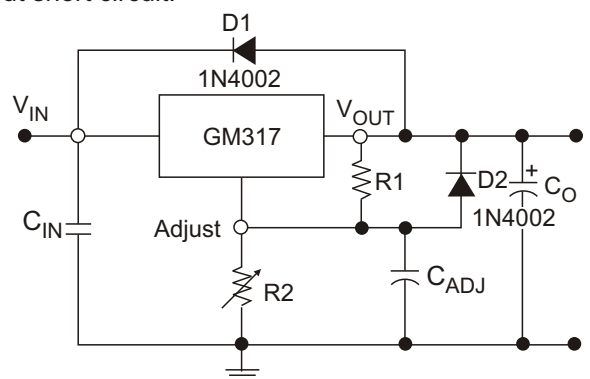

◆ TO-263-2 PACKAGE OUTLINE DIMENSIONS

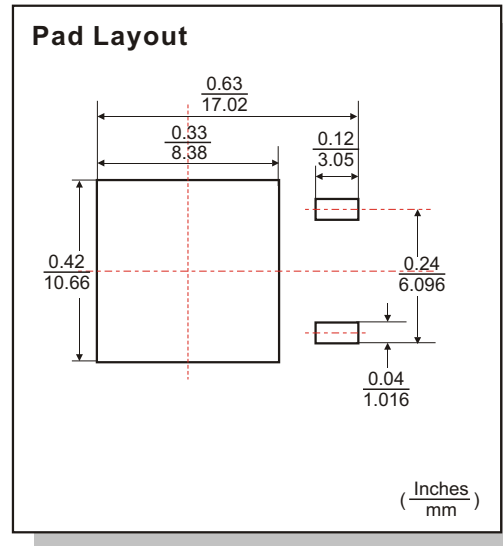
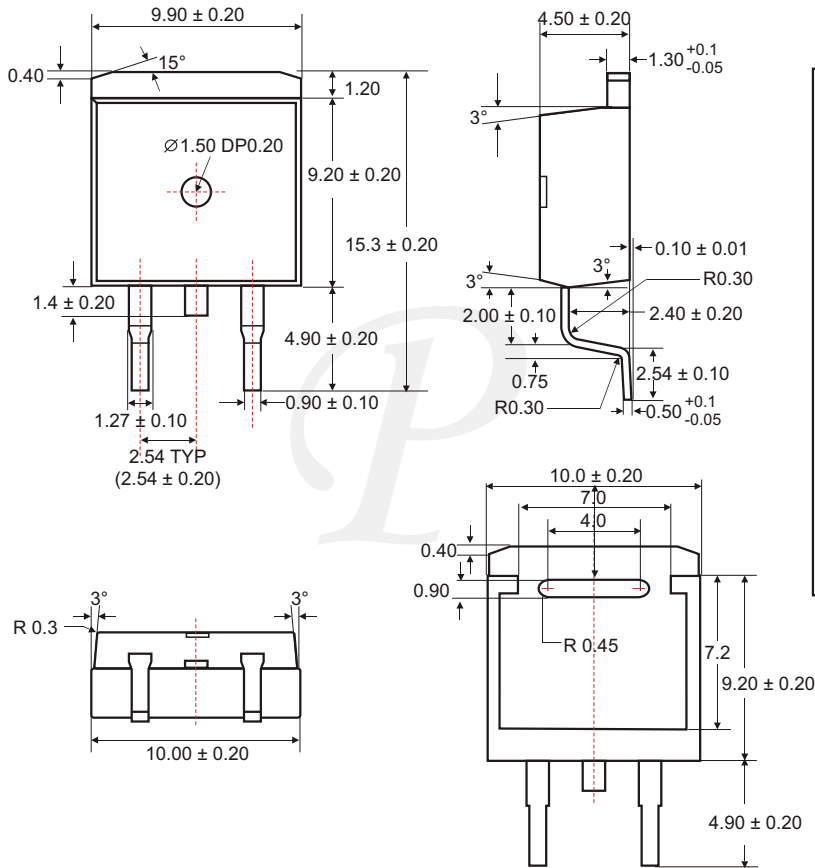

Unit: mm

◆ TO-220-3 PACKAGE OUTLINE DIMENSIONS

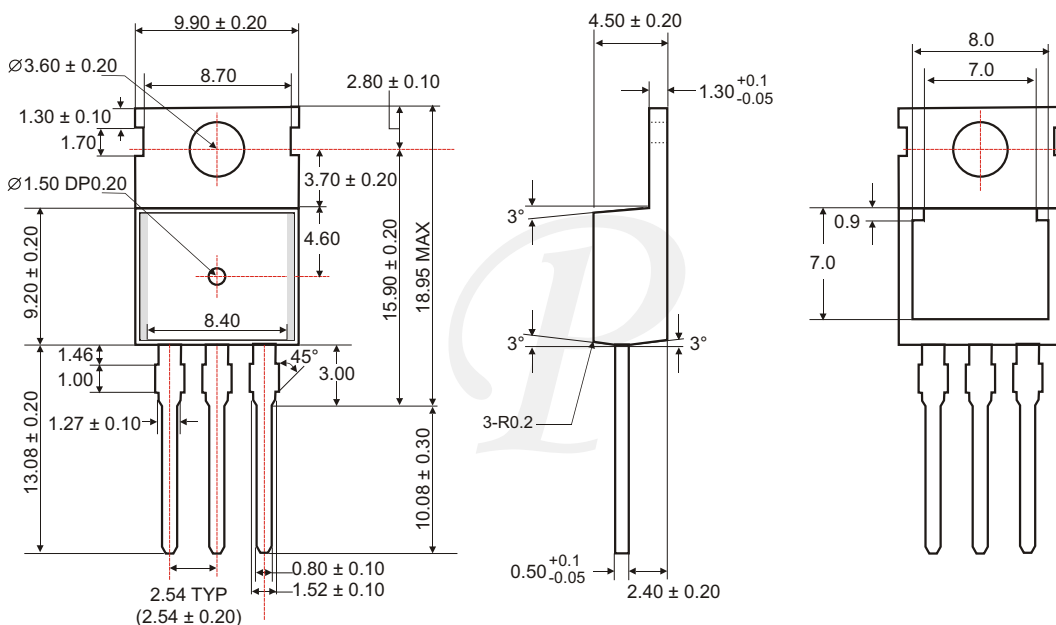

Unit: mm

◆ ORDERING NUMBER

