



SST Digital Temperature Sensor and Voltage Monitor

ADT7488A

FEATURES

- 1 on-chip temperature sensor
- 2 remote temperature sensors
- Monitors 3 voltage inputs, including V_{CC}
- Simple Serial Transport™ (SST™) interface

APPLICATIONS

- Personal computers
- Portable personal devices
- Industrial sensor nets

GENERAL DESCRIPTION

The ADT7488A is a simple digital temperature sensor for use in PC applications with Simple Serial Transport (SST) interface. It can monitor its own temperature as well as the temperature of two remote sensor diodes. It also measures the processor core voltage, V_{CCP} ; a 2.5 V supply voltage; and its own supply voltage, V_{CC} . The ADT7488A is controlled by an SST single bidirectional data line. This device is a fixed-address SST client where the target address is chosen by the state of the address pin, ADD.

FUNCTIONAL BLOCK DIAGRAM

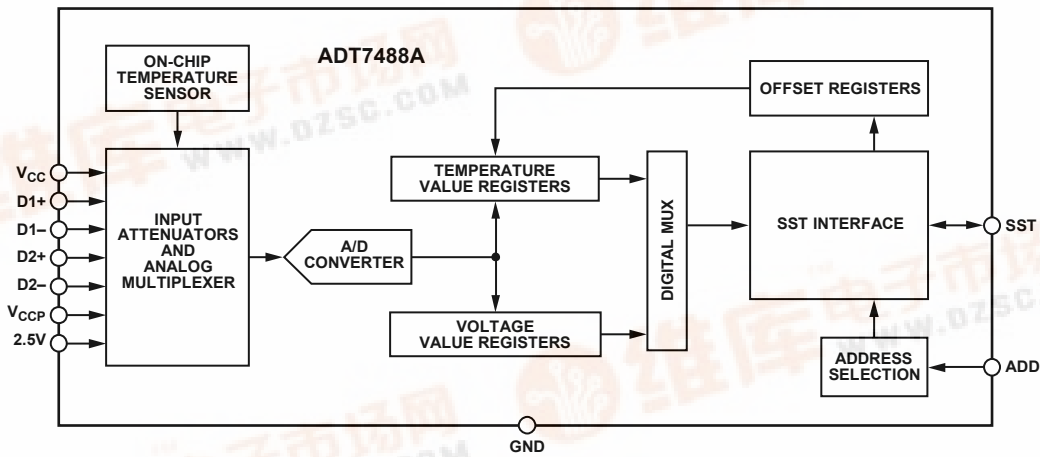

Figure 1.

06351-001



ADT7488A

TABLE OF CONTENTS

Features	1	Voltage Measurement	12
Applications.....	1	Analog-to-Digital Converter	12
General Description	1	Temperature Measurement	13
Functional Block Diagram	1	Temperature Measurement Method.....	13
Revision History	2	Reading Temperature Measurements	13
Specifications.....	3	SST Temperature Sensor Data Format	14
Absolute Maximum Ratings.....	5	Using Discrete Transistors	14
Thermal Resistance	5	Layout Considerations.....	14
ESD Caution.....	5	Temperature Offset	15
Pin Configuration and Functional Descriptions.....	6	Application Schematic	15
Typical Performance Characteristics	7	Outline Dimensions	16
Product Description	9	Ordering Guide	16
SST Interface	9		

REVISION HISTORY

9/06—Revision 0: Initial Version



SPECIFICATIONS

$T_A = T_{MIN}$ to T_{MAX} , $V_{CC} = V_{MIN}$ to V_{MAX} , unless otherwise noted.

Table 1.

Parameter	Min	Typ	Max	Unit	Test Conditions/Comments
POWER SUPPLY					
Supply Voltage, V_{CC}	3.0	3.3	3.6	V	
Undervoltage Lockout Threshold		2.8		V	
Average Operating Supply Current, I_{DD}		3.8	5	mA	Continuous conversions
TEMPERATURE-TO-DIGITAL CONVERTER					
Local Sensor Accuracy		+1	± 1.75	$^{\circ}\text{C}$	$40^{\circ}\text{C} \leq T_A \leq 70^{\circ}\text{C}$; $V_{CC} = 3.3\text{ V} \pm 5\%$
			± 4	$^{\circ}\text{C}$	$-40^{\circ}\text{C} \leq T_A \leq +100^{\circ}\text{C}$
Remote Sensor Accuracy			± 1	$^{\circ}\text{C}$	$-40^{\circ}\text{C} \leq T_D \leq +125^{\circ}\text{C}$; $T_A = 25^{\circ}\text{C}$; $V_{CC} = 3.3\text{ V}$
		+1	± 1.75	$^{\circ}\text{C}$	$-40^{\circ}\text{C} \leq T_D \leq +125^{\circ}\text{C}$; $-40 \leq T_A \leq 70^{\circ}\text{C}$; $V_{CC} = 3.3\text{ V} \pm 5\%$
			± 4	$^{\circ}\text{C}$	$-40^{\circ}\text{C} \leq T_D \leq +125^{\circ}\text{C}$; $-40 \leq T_A \leq +100^{\circ}\text{C}$
Remote Sensor Source Current		12		μA	Low level
		80		μA	Mid level
		204		μA	High level
Resolution		0.016		$^{\circ}\text{C}$	
Series Resistance Cancellation		1.5		k Ω	The ADT7488A cancels 1.5 k Ω in series with the remote thermal diode
DIGITAL INPUT (ADD)					
Input High Voltage, V_{IH}	2.3			V	
Input Low Voltage, V_{IL}			0.8	V	
Input High Current, I_{IH}	-1			μA	$V_{IN} = V_{CC}$
Input Low Current, I_{IL}			1	μA	$V_{IN} = 0$
Pin Capacitance		5		pF	
ANALOG-TO-DIGITAL CONVERTER (Including Multiplexer and Attenuators)					
Total Unadjusted Error (TUE)			± 1.5	%	
Differential Nonlinearity (DNL)			± 1	LSB	10 bits
Power Supply Sensitivity		± 0.1		%/V	
Conversion Time (Voltage Input) ¹			11	ms	Averaging enabled
Conversion Time (Local Temperature) ¹			12	ms	Averaging enabled
Conversion Time (Remote Temperature) ¹			38	ms	Averaging enabled
Total Monitoring Cycle Time ¹		121		ms	Averaging enabled
Input Resistances					
V_{CCP} and 2.5V Channels	80	110	140	k Ω	
DIGITAL I/O (SST Pin)					
Input High Voltage, V_{IH}	1.1			V	
Input Low Voltage, V_{IL}			0.4	V	
Hysteresis ¹		150		mV	Between input switching levels
Output High Voltage, V_{OH}	1.1		1.9	V	$I_{SOURCE} = 6\text{ mA}$ (maximum)
High Impedance State Leakage, I_{LEAK}			± 1	μA	Device powered on SST bus; $V_{SST} = 1.1\text{ V}$, $V_{CC} = 3.3\text{ V}$
High Impedance State Leakage, I_{LEAK}			± 10	μA	Device unpowered on SST bus; $V_{SST} = 1.1\text{ V}$, $V_{CC} = 0\text{ V}$
Signal Noise Immunity, V_{NOISE}	300			mV p-p	Noise glitches from 10 MHz to 100 MHz; width up to 50 ns



ADT7488A

Parameter	Min	Typ	Max	Unit	Test Conditions/Comments
SST TIMING					
Bitwise Period, t_{BIT}	0.495		500	μs	
High Level Time for Logic 1, t_{H1}^2	$0.6 \times t_{BIT}$	$0.75 \times t_{BIT}$	$0.8 \times t_{BIT}$	μs	t_{BIT} defined in speed negotiation
High Level Time for Logic 0, t_{H0}^2	$0.2 \times t_{BIT}$	$0.25 \times t_{BIT}$	$0.4 \times t_{BIT}$	μs	
Time to Assert SST High for Logic 1, $t_{SU,HIGH}$			$0.2 \times t_{BIT}$	μs	
Hold Time, t_{HOLD}^3			$0.5 \times t_{BIT-M}$	μs	See SST Specification Rev 1.0
Stop Time, t_{STOP}	$1.25 \times t_{BIT}$	$2 \times t_{BIT}$	$2 \times t_{BIT}$	μs	Device responding to a constant low level driven by originator
Time to Respond After a Reset, t_{RESET}			0.4	ms	
Response Time to Speed Negotiation After Power-Up		500		μs	Time after power-up when device can participate in speed negotiation

¹ Guaranteed by design, not production tested.

² Minimum and maximum bit times are relative to t_{BIT} defined in the timing negotiation pulse.

³ Device is compatible with hold time specification as driven by SST originator.



ABSOLUTE MAXIMUM RATINGS

Table 2.

Parameter	Rating
Supply Voltage (V_{CC})	4 V
Voltage on 2.5V and V_{CCP} Pins	3.6 V
Voltage on Any Other Pin (Including SST Pin)	-0.3 V to +3.6 V
Input Current at Any Pin	± 5 mA
Package Input Current	± 20 mA
Maximum Junction Temperature (T_J max)	150°C
Storage Temperature Range	-65°C to +150°C
Lead Temperature, Soldering	
IR Peak Reflow Temperature	260°C
Lead Temperature (10 sec)	300°C
ESD Rating	1500 V

Stresses above those listed under Absolute Maximum Ratings may cause permanent damage to the device. This is a stress rating only; functional operation of the device at these or any other conditions above those indicated in the operational section of this specification is not implied. Exposure to absolute maximum rating conditions for extended periods may affect device reliability.

THERMAL RESISTANCE

θ_{JA} is specified for the worst-case conditions, that is, a device soldered in a circuit board for surface-mount packages.

Table 3. Thermal Resistance

Package Type	θ_{JA}	θ_{JC}	Unit
10-Lead MSOP	206	44	°C/W

ESD CAUTION



ESD (electrostatic discharge) sensitive device. Charged devices and circuit boards can discharge without detection. Although this product features patented or proprietary protection circuitry, damage may occur on devices subjected to high energy ESD. Therefore, proper ESD precautions should be taken to avoid performance degradation or loss of functionality.

ADT7488A

PIN CONFIGURATION AND FUNCTIONAL DESCRIPTIONS

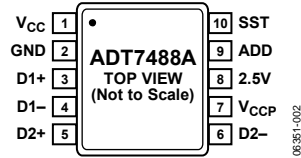

Table 4. Pin Function Descriptions

Pin No.	Mnemonic	Type	Description
1	V _{CC}	Power supply	3.3 V ± 10%. V _{CC} is also monitored through this pin.
2	GND	Ground	Ground Pin.
3	D1+	Analog input	Positive Connection to Remote 1 Temperature Sensor.
4	D1-	Analog input	Negative Connection to Remote 1 Temperature Sensor.
5	D2+	Analog input	Positive Connection to Remote 2 Temperature Sensor.
6	D2-	Analog input	Negative Connection to Remote 2 Temperature Sensor.
7	V _{CCP}	Analog input	Processor Core Voltage Monitor.
8	2.5V	Analog input	2.5 V Supply Monitor.
9	ADD	Digital input	SST Address Select.
10	SST	Digital input/output	SST Bidirectional Data Line.



TYPICAL PERFORMANCE CHARACTERISTICS

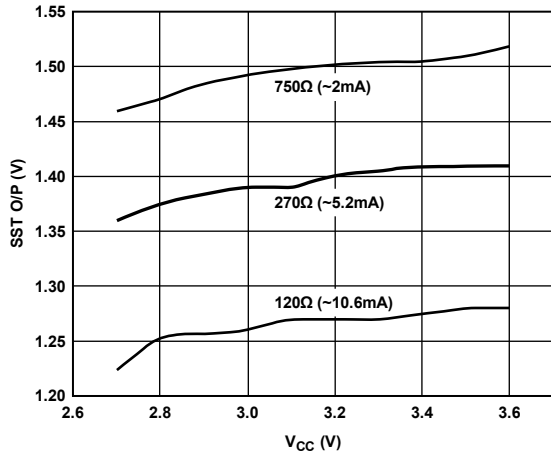

Figure 3. SST O/P Level vs. Supply Voltage

06351-007

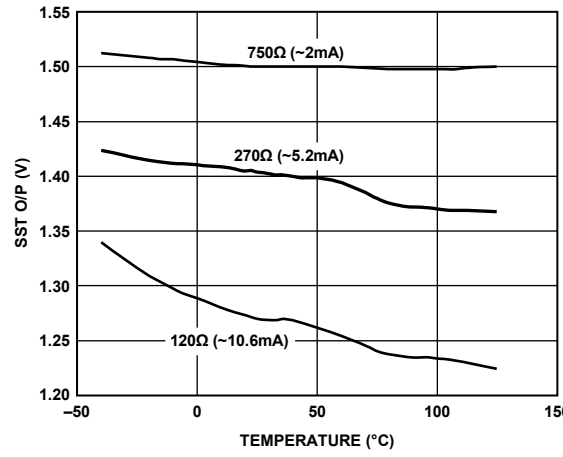

Figure 6. SST O/P Level vs. Temperature

06351-010

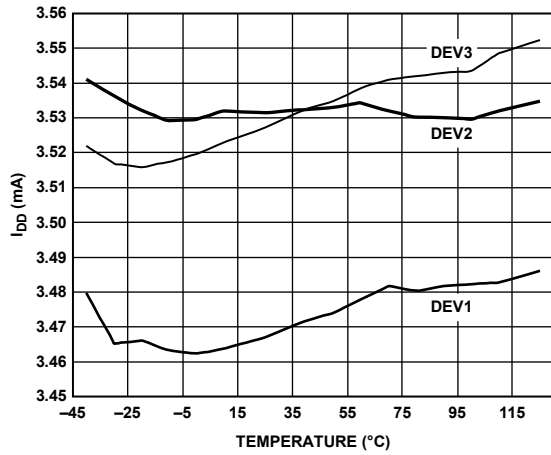

Figure 4. Supply Current vs. Temperature

06351-008

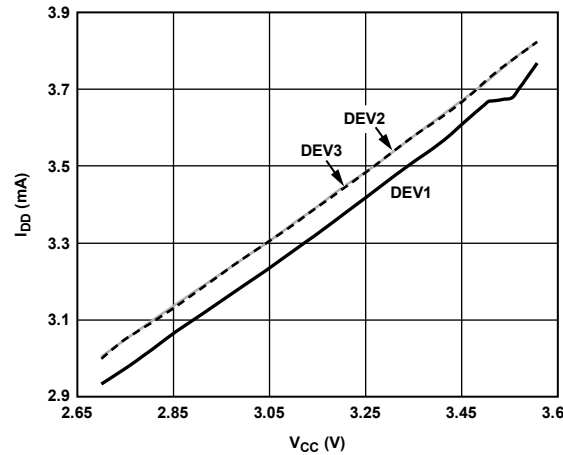

Figure 7. Supply Current vs. Voltage

06351-011

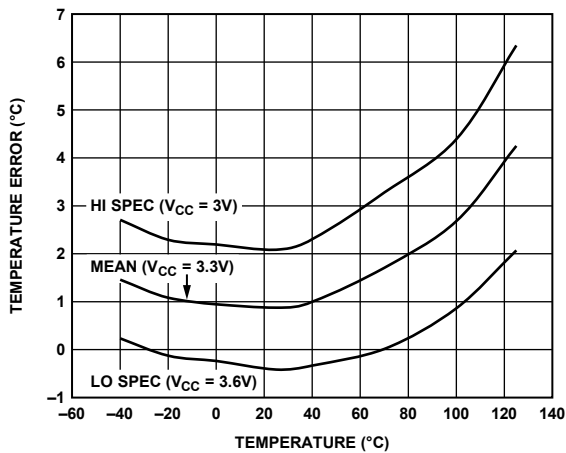

Figure 5. Local Temperature Error

06351-019

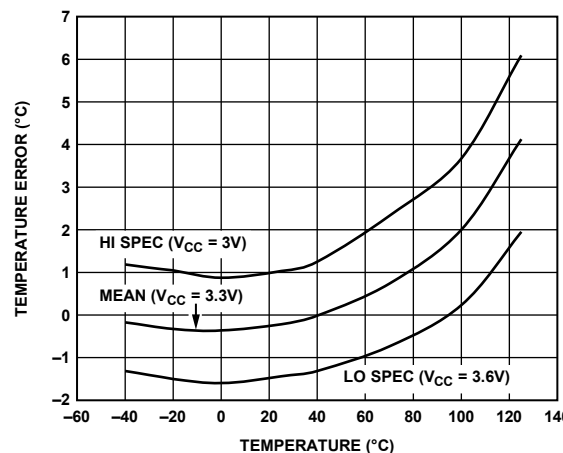

Figure 8. Remote Temperature Error

06351-020



ADT7488A

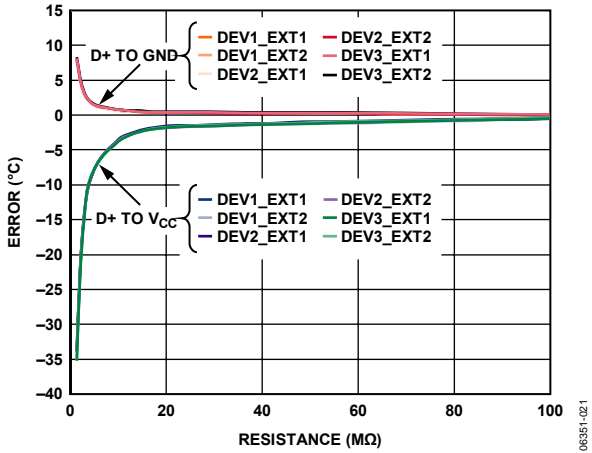

Figure 9. Remote Temperature Error vs. PCB Resistance

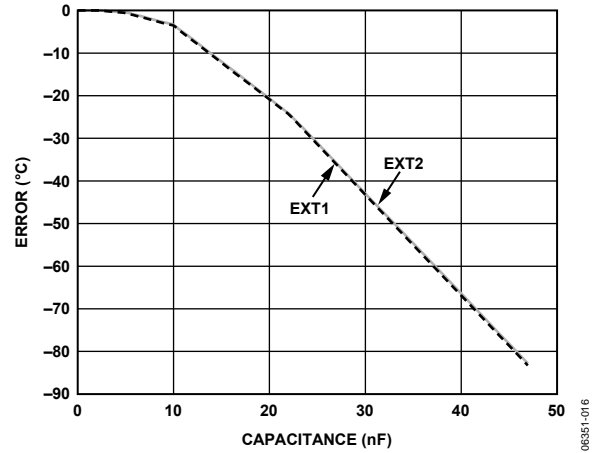

Figure 12. Remote Temperature Error vs. Capacitance Between D1+ and D1-

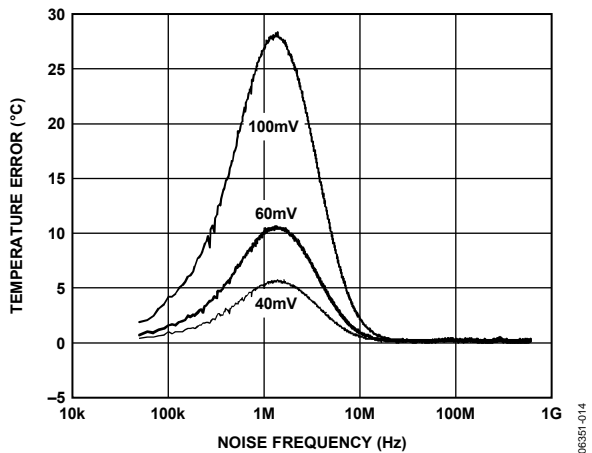

Figure 10. Temperature Error vs. Common-Mode Noise Frequency

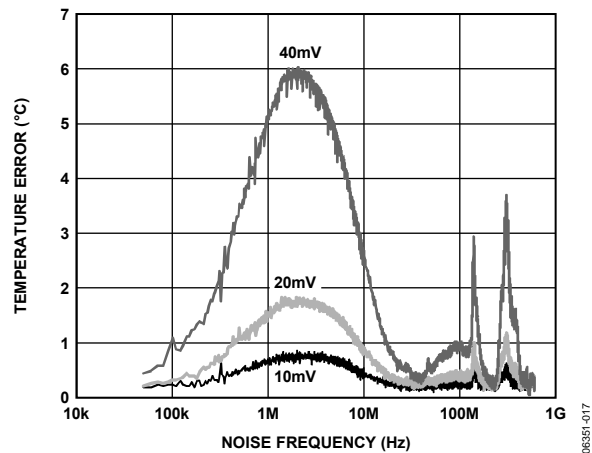

Figure 13. Temperature Error vs. Differential-Mode Noise Frequency

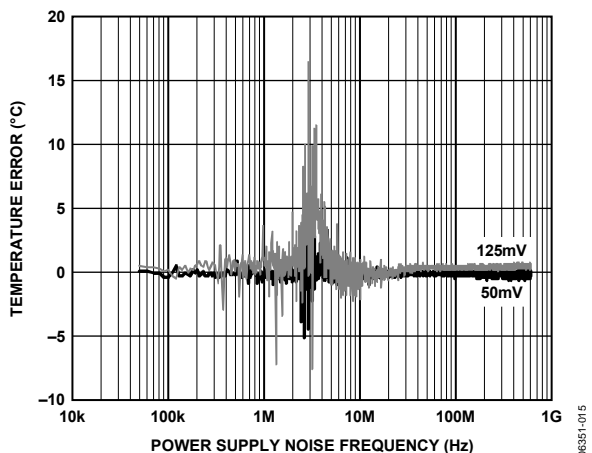

Figure 11. Local Temperature Error vs. Power Supply Noise

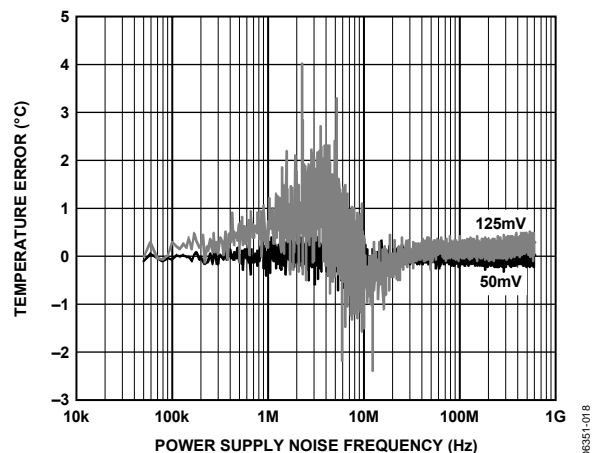

Figure 14. Remote Temperature Error vs. Power Supply Noise



PRODUCT DESCRIPTION

The ADT7488A is a temperature- and voltage-monitoring device. The ADT7488A can monitor the temperature of two remote sensor diodes, plus its own internal temperature. It can also monitor up to three voltage channels, including its own supply voltage.

SST INTERFACE

Simple Serial Transport (SST) is a one-wire serial bus and a communications protocol between components intended for use in personal computers, personal hand-held devices, or other industrial sensor nets. The ADT7488A supports SST Rev 1.0.

SST is a licensable bus technology from Analog Devices, Inc., and Intel Corporation. To inquire about obtaining a copy of the Simple Serial Transport Specification or an SST technology license, please email Analog Devices at sst_licensing@analog.com or write to Analog Devices, 3550 North First Street, San Jose, CA 95134, Attention: SST Licensing, M/S B7-24.

ADT7488A Client Address

The client address for the ADT7488A is selected using the address pin. The address pin is connected to a float detection circuit, which allows the ADT7488A to distinguish between three input states: high, low (GND), and floating. The address range for the fixed address, discoverable device is 0x48 to 0x4A.

Table 5. ADT7488A Selectable Addresses

ADD	Address Selected
Low (GND)	0x48
Float	0x49
High	0x4A



ADT7488A

Command Summary

Table 6 summarizes the commands supported by the ADT7488A device when directed at the target address selected by the fixed address pin. It contains the command name, command code (CC), write data length (WL), read data length (RL), and a brief description.

Table 6. Command Code Summary

Command	Command Code, CC	Write Length, WL	Read Length, RL	Description
Ping()	0x00	0x00	0x00	Shows a nonzero FCS over the header if present.
GetIntTemp()	0x00	0x01	0x02	Shows the temperature of the device's internal thermal diode.
GetExt1Temp()	0x01	0x01	0x02	Shows the temperature of External Thermal Diode 1.
GetExt2Temp()	0x02	0x01	0x02	Shows the temperature of External Thermal Diode 2.
GetAllTemps()	0x00	0x01	0x06	Returns a 6-byte block of data (GetIntTemp, GetExt1Temp, GetExt2Temp).
GetVoltVCC()	0x12	0x01	0x02	Shows the voltage attached to V _{CC} input.
GetVolt2.5V()	0x13	0x01	0x02	Shows the voltage attached to 2.5V input.
GetVoltVCCP()	0x14	0x01	0x02	Shows the voltage attached to V _{CCP} input.
GetAllVolts()	0x12	0x01	0x06	Shows all voltage measurements in a 6-byte block of data (GetVoltVcc, GetVolt2.5, GetVoltVccp).
SetExt1Offset()	0xe0	0x03	0x00	Sets the offset used to correct errors in External Diode 1.
GetExt1Offset()	0xe0	0x01	0x02	Shows the offset that the device is using to correct errors in External Diode 1.
SetExt2Offset()	0xe1	0x03	0x00	Sets the offset used to correct errors in External Diode 2.
GetExt2Offset() ()	0xe1	0x01	0x02	Returns the offset the device is using to correct errors in External Diode 2.
ResetDevice()	0xf6	0x01	0x00	Functional reset. The ADT7488A also responds to this command when directed to the Target Address 0x00.
GetDIB()	0xf7 0xf7	0x01 0x01	0x08 0x10	Shows information used by SW to identify the device's capabilities. Can be in 8- or 16-byte format.



Command Code Details

ADT7488A Device Identifier Block

The GetDIB() command retrieves the device identifier block (DIB), which provides information to identify the capabilities of the ADT7488A. The data returned can be in 8- or 16-byte format. The full 16 bytes of DIB is detailed in Table 7. The 8-byte format involves the first eight bytes described in this table. Byte-sized data is returned in the respective fields as it appears in Table 7. Word-sized data, including vendor ID, device ID, and data values use little endian format, that is, the LSB is returned first, followed by the MSB.

Table 7. 16-Byte DIB Details

Byte	Name	Value	Description
0	Device Capabilities	0xc0	Fixed address device
1	Version/Revision	0x10	Meets Version 1 of the SST specification
2, 3	Vendor ID	00x11d4	Contains company ID number in little endian format
4, 5	Device ID	0x7488	Contains device ID number in little endian format
6	Device Interface	0x01	SST device
7	Function Interface	0x00	Reserved
8	Reserved	0x00	Reserved
9	Reserved	0x00	Reserved
10	Reserved	0x00	Reserved
11	Reserved	0x00	Reserved
12	Reserved	0x00	Reserved
13	Reserved	0x00	Reserved
14	Revision ID	0x05	Contains revision ID
15	Client Device Address	0x48 to 0x4a	Dependent on the state of the address pin

Ping()

The Ping() command verifies if a device is responding at a particular address. The ADT7488A shows a valid nonzero FCS in response to the Ping() command when correctly addressed.

Table 8. Ping() Command

Target Address	Write Length	Read Length	FCS
(Not necessary)	0x00	0x00	

ResetDevice()

This command resets the register map and conversion controller. The reset command can be global or directed at the client address of the ADT7488A.

Table 9. ResetDevice() Command

Target Address	Write Length	Read Length	Reset command	FCS
Device Address	0x01	0x00	0xf6	

GetIntTemp()

The ADT7488A shows the local temperature of the device in response to the GetIntTemp() command. The data has a little endian, 16-bit, twos complement format.

GetExt1Temp()

Prompted by the GetExt1Temp() command, the ADT7488A shows the temperature of Remote Diode 1 in little endian, 16-bit, twos complement format. The ADT7488A shows 0x8000 in response to this command if the external diode is an open or short circuit.

GetExt2Temp()

Prompted by the GetExt2Temp() command, ADT7488A shows the temperature of Remote Diode 2 in little endian, 16-bit, twos complement format. The ADT7488A shows 0x8000 in response to this command if the external diode is an open or short circuit.

GetAllTemps()

The ADT7488A shows the local and remote temperatures in a 6-byte block of data (internal temperature first, followed by External 1 temperature, followed by External 2 temperature) in response to a GetAllTemps() command.

SetExtOffset()

This command sets the offset that the ADT7488A will use to correct errors in the external diode. The offset is set in little endian, 16-bit, twos complement format. The maximum offset is $\pm 128^{\circ}\text{C}$ with $+0.25^{\circ}\text{C}$ resolution.

GetExtOffset()

This command causes the ADT7488A to show the offset that it is using to correct errors in the external diode. The offset value is returned in little endian format, that is, LSB before MSB.

ADT7488A Response to Unsupported Commands

A full list of command codes supported by the ADT7488A is given in Table 6. The offset registers (Command Code 0xe0) are the only registers that the user can write to. The other defined registers are read only. Writing to Register Addresses 0x02, 0x09, and 0x15 to 0xdf shows a valid FCS, but no action is taken by the ADT7488A. The ADT7488A shows an invalid FCS if the user attempts to write to the device between Command Codes 0xe2 to 0xee. These registers are reserved for the manufacturer's use only, and no data can be written to the device via these addresses.



ADT7488A

VOLTAGE MEASUREMENT

The ADT7488A has two external voltage measurement channels. It can also measure its own supply voltage, V_{CC} . Pins 7 and 8 measure the supplies of the processor core voltage (V_{CCP}), and 2.5V pins, respectively. The V_{CC} supply voltage measurement is carried out through the V_{CC} pin (Pin 1). The 2.5V pin can be used to monitor a chipset supply voltage in a computer system.

ANALOG-TO-DIGITAL CONVERTER

All analog inputs are multiplexed into the on-chip, successive approximation, analog-to-digital converter (ADC). This has a resolution of 10 bits. The basic input range is 0 V to 2.25 V, but the inputs have built-in attenuators to allow measurement of 2.5 V, 3.3 V, 5 V, 12 V, and the processor core voltage (V_{CCP}) without any external components.

To allow for the tolerance of these supply voltages, the ADC produces a specific output for each nominal input voltage and therefore has adequate headroom to cope with overvoltages. The full-scale voltage that can be recorded for each channel is shown in Table 10.

Table 10. Maximum Reported Input Voltages

Voltage Channel	Full-Scale Voltage
V_{CC}	4 V
2.5V	4 V
V_{CCP}	4 V

Input Circuitry

The internal structure for the analog inputs is shown in Figure 15. The input circuit consists of an input protection diode and an attenuator, plus a capacitor that forms a first-order, low-pass filter to provide input immunity to high frequency noise.

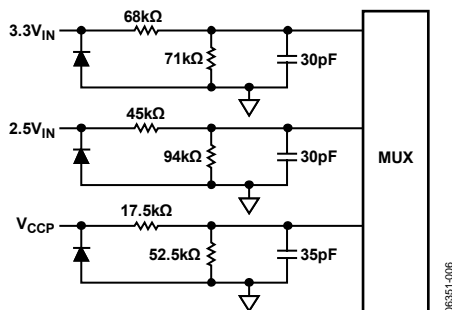

Figure 15. Internal Structure of Analog Inputs

Voltage Measurement Command Codes

The voltage measurement command codes are detailed in Table 11. Each voltage measurement has a read length of two bytes in little endian format (LSB followed by MSB). All voltages can be read together by addressing Command Code 0x12 with a read length of 0x06. The data is retrieved in the order listed in Table 11.

Table 11. Voltage Measurement Command Codes

Voltage Channel	Command Code	Returned Data
V_{CC}	0x12	LSB, MSB
2.5V	0x13	LSB, MSB
V_{CCP}	0x14	LSB, MSB

Voltage Data Format

The returned voltage value is in twos complement, 16-bit, binary format. The format is structured so that voltages in the range of ± 32 V can be reported. In this way, the reported value represents the number of 1/1024 V in the actual reading, allowing a resolution of approximately 1 mV.

Table 12. Analog-to-Digital Output Code vs. V_{IN}

Voltage	Twos Complement	
	MSB	LSB
3.3	0000 1101	0011 0011
3	0000 1100	0000 0000
2.5	0000 1010	0000 0000
1	0000 0100	0000 0000
0	0000 0000	0000 0000



TEMPERATURE MEASUREMENT

The ADT7488A has three dedicated temperature measurement channels: one for measuring the temperature of an on-chip band gap temperature sensor, and two for measuring the temperature of a remote diode, usually located in the CPU or GPU.

The ADT7488A monitors one local and two remote temperature channels. Monitoring of each of the channels is done in a round-robin sequence. The monitoring sequence is in the order shown in Table 13.

Table 13. Temperature Monitoring Sequence

Channel Number	Measurement	Conversion Time (ms)
0	Local temperature	12
1	Remote 1 temperature	38
2	Remote 2 temperature	38

TEMPERATURE MEASUREMENT METHOD

A simple method for measuring temperature is to exploit the negative temperature coefficient of a diode by measuring the base-emitter voltage (V_{BE}) of a transistor operated at constant current. Unfortunately, this technique requires calibration to null the effect of the absolute value of V_{BE} , which varies from device to device.

The technique used in the ADT7488A measures the change in V_{BE} when the device is operated at three different currents.

Figure 16 shows the input signal conditioning used to measure the output of a remote temperature sensor. This figure shows the remote sensor as a substrate transistor, which is provided for temperature monitoring on some microprocessors, but it could also be a discrete transistor. If a discrete transistor is used, the collector is not grounded and should be linked to the base. To prevent ground noise from interfering with the measurement, the more negative terminal of the sensor is not referenced to ground, but is biased above ground by an internal diode at the D1- input. If the sensor is operating in an extremely noisy environment, C1 can be added as a noise filter. Its value should not exceed 1000 pF.

To measure ΔV_{BE} , the operating current through the sensor is switched between three related currents. Figure 16 shows $N1 \times I$ and $N2 \times I$ as different multiples of the current I . The currents through the temperature diode are switched between I and $N1 \times I$, giving ΔV_{BE1} , and then between I and $N2 \times I$, giving ΔV_{BE2} . The temperature can then be calculated using the two ΔV_{BE} measurements. This method can also cancel the effect of series resistance on the temperature measurement. The resulting ΔV_{BE} waveforms are passed through a 65 kHz low-pass filter to remove noise and then through a chopper-stabilized amplifier to amplify and rectify the waveform, producing a dc voltage proportional to ΔV_{BE} . The ADC digitizes this voltage, and a temperature measurement is produced. To reduce the effects of noise, digital filtering is performed by averaging the results of 16 measurement cycles for low conversion rates. Signal conditioning and measurement of the internal temperature sensor is performed in the same manner.

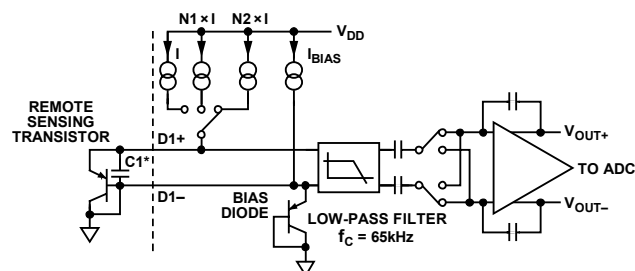

*CAPACITOR C1 IS OPTIONAL. IT SHOULD ONLY BE USED IN NOISY ENVIRONMENTS.

Figure 16. Signal Conditioning for Remote Diode Temperature Sensors

READING TEMPERATURE MEASUREMENTS

The temperature data returned is two bytes in little endian format, that is, LSB before MSB. All temperatures can be read together by using Command Code 0x00 with a read length of 0x06. The command codes and returned data are described in Table 14.

Table 14. Temperature Channel Command Codes

Temp Channel	Command Code	Returned data
Internal	0x00	LSB, MSB
External 1	0x01	LSB, MSB
External 2	0x02	LSB, MSB
All Temps	0x00	Internal LSB, internal MSB; External 1 LSB, External 1 MSB, External 2 LSB, External 2 MSB



ADT7488A

SST TEMPERATURE SENSOR DATA FORMAT

The data for temperature is structured to allow values in the range of $\pm 512^{\circ}\text{C}$ to be reported. Thus, the temperature sensor format uses a twos complement, 16-bit binary value to represent values in this range. This format allows temperatures to be represented with approximately a 0.016°C resolution.

Table 15. SST Temperature Data Format

Temperature ($^{\circ}\text{C}$)	Twos Complement	
	MSB	LSB
-125	1110 0000	1100 0000
-80	1110 1100	0000 0000
-40	1111 0110	0000 0000
-20	1111 1011	0011 1110
-5	1111 1110	1100 0000
-1	1111 1111	1100 0000
0	0000 0000	0000 0000
+1	0000 0000	0100 0000
+5	0000 0001	0100 0000
+20	0000 0100	1100 0010
+40	0000 1010	0000 0000
+80	0001 0100	0000 0000
+125	0001 1111	0100 0000

USING DISCRETE TRANSISTORS

If a discrete transistor is used, the collector is not grounded and should be linked to the base. If a PNP transistor is used, the base is connected to the D- input and the emitter is connected to the D+ input. If an NPN transistor is used, the emitter is connected to the D- input and the base is connected to the D+ input.

Figure 17 shows how to connect the ADT7488A to an NPN or PNP transistor for temperature measurement. To prevent ground noise from interfering with the measurement, the more negative terminal of the sensor is not referenced to ground, but is biased above ground by an internal diode at the D- input.

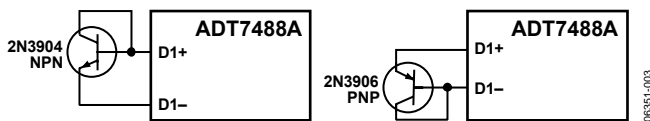

Figure 17. Connections for NPN and PNP Transistors

The ADT7488A shows an external temperature value of $0x8000$ if the external diode is an open or short circuit.

LAYOUT CONSIDERATIONS

Digital boards can be electrically noisy environments. Take the following precautions to protect the analog inputs from noise, particularly when measuring the very small voltages from a remote diode sensor:

- Place the ADT7488A as close as possible to the remote sensing diode. Provided that the worst noise sources, such as clock generators, data/address buses, and CRTs, are avoided, this distance can be four to eight inches.
- Route the D1+ and D1- tracks close together in parallel with grounded guard tracks on each side. Provide a ground plane under the tracks if possible.
- Use wide tracks to minimize inductance and reduce noise pickup. A 5 mil track minimum width and spacing is recommended.



Figure 18. Arrangements of Signal Tracks

- Try to minimize the number of copper/solder joints, which can cause thermocouple effects. Where copper/solder joints are used, make sure that they are in both the D1+ and D1- paths and are at the same temperature.
- Thermocouple effects should not be a major problem because 1°C corresponds to about $240\ \mu\text{V}$, and thermocouple voltages are about $3\ \mu\text{V}/^{\circ}\text{C}$ of the temperature difference. Unless there are two thermocouples with a big temperature differential between them, thermocouple voltages should be much less than $200\ \text{mV}$.
- Place a $0.1\ \mu\text{F}$ bypass capacitor close to the ADT7488A.
- If the distance to the remote sensor is more than eight inches, the use of a twisted pair cable is recommended. This works for distances of about 6 feet to 12 feet.
- For very long distances (up to 100 feet), use shielded twisted pair cables, such as Belden #8451 microphone cables. Connect the twisted pair cable to D+ and D- and the shield to GND, close to the ADT7488A. Leave the remote end of the shield unconnected to avoid ground loops.

Because the measurement technique uses switched current sources, excessive cable and/or filter capacitance can affect the measurement. When using long cables, the filter capacitor can be reduced or removed. Cable resistance can also introduce errors. A $1\ \Omega$ series resistance introduces about 0.5°C error.



TEMPERATURE OFFSET

As CPUs run faster, it is more difficult to avoid high frequency clocks when routing the D+ and D- tracks around a system board. Even when the recommended layout guidelines are followed, there may still be temperature errors, attributed to noise being coupled onto the D+ and D- lines. High frequency noise generally has the effect of producing temperature measurements that are consistently too high by a specific amount. The ADT7488A has temperature offset command codes of 0xe0 and 0xe1 through which a desired offset can be set. By doing a one-time calibration of the system, the offset caused by system board noise can be calculated and nulled by specifying it in the ADT7488A. The

offset is automatically added to every temperature measurement. The maximum offset is $\pm 128^{\circ}\text{C}$ with 0.25°C resolution. The offset format is the same as the temperature data format—16-bit, twos complement notation, as shown in Table 15. The offset should be programmed in little endian format, that is, LSB before MSB. The offset value is also returned in little endian format when read.

APPLICATION SCHEMATIC

A typical application circuit for the ADT7488A is shown in Figure 19. The ADT7488A can be used in conjunction with the [ADP3192](#) controller to monitor the CPU power. The result is a complete thermal and power monitor for the CPU.

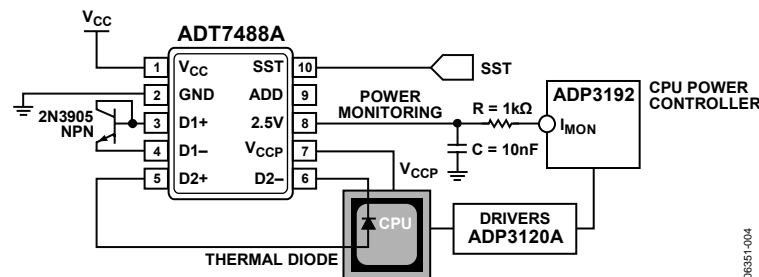

Figure 19. ADT7488A Application Schematic: CPU Thermal- and Power-Supply Monitoring

06351-1-004



ADT7488A

OUTLINE DIMENSIONS

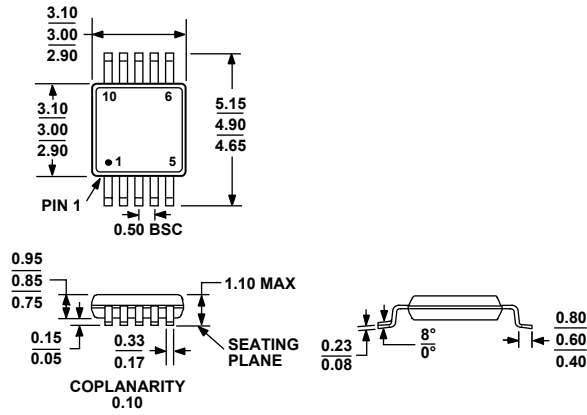

COMPLIANT TO JEDEC STANDARDS MO-187-BA
 Figure 20. 10-Lead Mini Small Outline Package [MSOP]
 (RM-10)
 Dimensions shown in millimeters

ORDERING GUIDE

Model	Temperature Range	Package Description	Package Option	Branding
ADT7488AARMZ-REEL ¹	-40°C to +125°C	10-Lead MSOP	RM-10	T24
ADT7488AARMZ-REEL7 ¹	-40°C to +125°C	10-Lead MSOP	RM-10	T24

¹ Z = Pb-free part.