



March 2006

# LP3971

## Power Management Unit for Advanced Application Processors

### General Description

The LP3971 is a multi-function, programmable Power Management Unit, designed especially for advanced application processors. The LP3971 is optimized for low power handheld applications and provides 6 low dropout, low noise linear regulators, three DC/DC magnetic buck regulators, a back-up battery charger and two GPIO's. A high speed serial interface is included to program individual regulator output voltages as well as on/off control.

### Key Specifications

#### Buck Regulators

- Programmable  $V_{OUT}$  from 0.8 to 3.3V
- Up to 95% efficiency
- Up to 1.6A output current
- $\pm 3\%$  output voltage accuracy

#### LDO's

- Programmable  $V_{OUT}$  of 1.0V–3.3V
- $\pm 3\%$  output voltage accuracy
- 150/300/370 mA output currents
  - LDO RTC 30 mA
  - LDO 1 300 mA
  - LDO 2 150 mA
  - LDO 3 150 mA
  - LDO 4 150 mA
  - LDO 5 370 mA
- 100 mV (typ) dropout

### Features

- Compatible with advanced applications processors requiring DVM (Dynamic Voltage Management)
- Three buck regulators for powering high current processor functions or I/O's
- 6 LDO's for powering RTC, peripherals, and I/O's
- Backup battery charger with automatic switch for lithium-manganese coin cell batteries and Super capacitors
- I<sup>2</sup>C compatible high speed serial interface
- Software control of regulator functions and settings
- Precision internal reference
- Thermal overload protection
- Current overload protection
- Tiny 40-pin 5x5 mm LLP package

### Applications

- PDA phones
- Smart phones
- Personal Media Players
- Digital cameras
- Application processors
  - Intel Xscale
  - Freescale
  - Samsung

LP3971 Power Management Unit for Advanced Application Processors



### Simplified Application Circuit

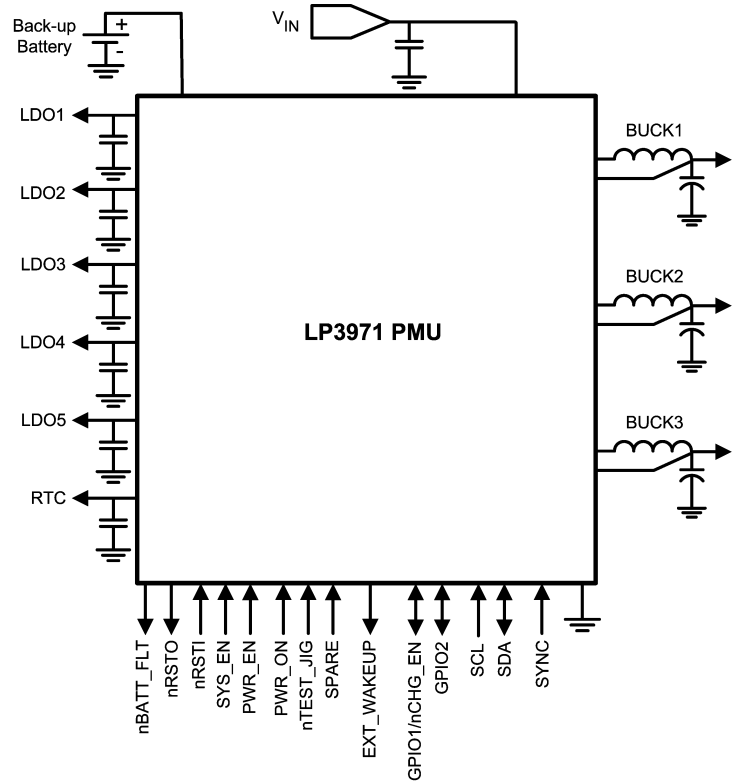

20180701

### Connection Diagrams and Package Mark Information

40-Pin Leadless Leadframe Package  
NS Package Number SQF40A

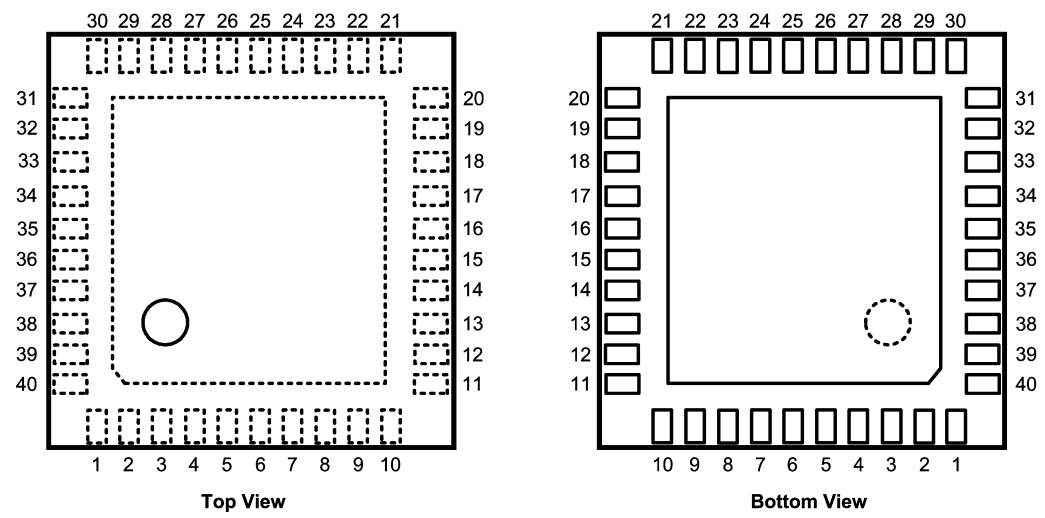

Note: Circle marks pin 1 position.

20180702



## Connection Diagrams and Package Mark Information (Continued)



**Note:** The actual physical placement of the package marking will vary from part to part. The package marking “UZY” designates the date code. “TT” is a NSC internal code for die traceability. Both will vary considerably. “LP3971SQF” identifies the device (part number, option, etc.).

### Ordering Information

Option	Order Number	Package Marking	Supplied As
Default Voltage version – A***	LP3971SQ-A514	71-A514	250 units, Tape-and-Reel
Default Voltage version – A**	LP3971SQX-A514	71-A514	2500 units, Tape-and-Reel
Default Voltage version - B	LP3971SQ-B410	71-B410	250 units, Tape-and-Reel
Default Voltage version - B	LP3971SQX-B410	71-B410	2500 units, Tape-and-Reel

\*\*\* To be Released

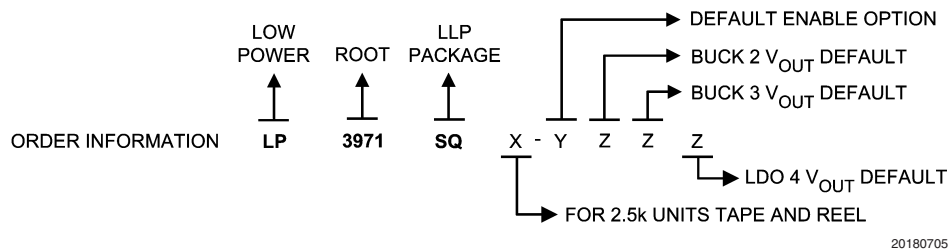

### Default V<sub>OUT</sub> Coding

Z	Default V <sub>OUT</sub>
0	1.3
1	1.8
2	2.5
3	2.8
4	3.0
5	3.3



## Pin Descriptions

Pin #	Name	I/O	Type	Description
1	PWR_ON	I	D	CPU Wakeup input
2	nTEST_JIG	I	D	CPU Wakeup input
3	SPARE	I	D	CPU Wakeup input
4	EXT_WAKEUP	O	D	CPU Wakeup output
5	FB1	I	A	Buck1 Feedback
6	V <sub>IN</sub>	I	P	Battery Input (Internal circuitry and LDO1–3 power input)
7	V <sub>OUT</sub> LDO1	O	P	LDO1 output
8	V <sub>OUT</sub> LDO2	O	P	LDO2 output
9	nRST1	I	D	Reset Input
10	GND1	G	G	Ground
11	V <sub>REF</sub>	O	A	Bypass Cap. for reference
12	V <sub>OUT</sub> LDO3	O	P	LDO3 output
13	V <sub>OUT</sub> LDO4	O	P	LDO4 output
14	V <sub>IN</sub> LDO4	I	P	Input power for LDO4
15	V <sub>IN</sub> BUBATT	I	P	Back Up Battery input
16	V <sub>OUT</sub> LDO_RTC	O	P	LDO_RTC output
17	nBATT_FLT	O	D	Main Battery fault output
18	PGND2	G	G	Buck2 NMOS Power Ground
19	SW2	O	P	Buck2 Output
20	V <sub>IN</sub> Buck2	I	P	Buck2 battery input
21	SDA	I/O	D	I <sup>2</sup> C Data
22	SCL	I	D	I <sup>2</sup> C Clock
23	FB2	I	A	Buck2 Feedback
24	nRSTO	O	D	Reset output
25	V <sub>OUT</sub> LDO5	O	P	LDO5 output
26	V <sub>IN</sub> LDO5	I	P	Input power for LDO5
27	VDDA	I	P	Analog Power
28	FB3	I	A	Buck3 Feedback
29	GPIO1/nCHG_EN	I/O	D	General Purpose I/O/Ext. backup battery charger enable
30	GPIO2	I/O	D	General Purpose I/O
31	V <sub>IN</sub> Buck3	I	P	Buck3 battery input
32	SW3	O	P	Buck3 Output
33	PGND3	G	G	Buck3 NMOS Power Ground
34	BGND1,2,3	G	G	Bucks 1, 2 and 3 analog Ground
35	SYNC	I	D	Bucks external clock input
36	SYS_EN	I	D	High voltage domain enable
37	PWR_EN	I	D	Low Voltage domain enable
38	PGND1	G	G	Buck1 NMOS Power Ground
39	SW1	O	P	Buck1 Output
40	V <sub>IN</sub> Buck1	I	P	Buck1 battery input

A: Analog Pin

D: Digital Pin

G: Ground Pin

P: Power Pin

I: Input Pin

I/O: Input/Output Pin

O: Output Pin

**Note:** In this document active low logic items are prefixed with a lowercase “n”



# Applications Schematic Diagrams

Diagram 1 LDO 4 and LDO5 Connected To V<sub>BATTERY</sub>

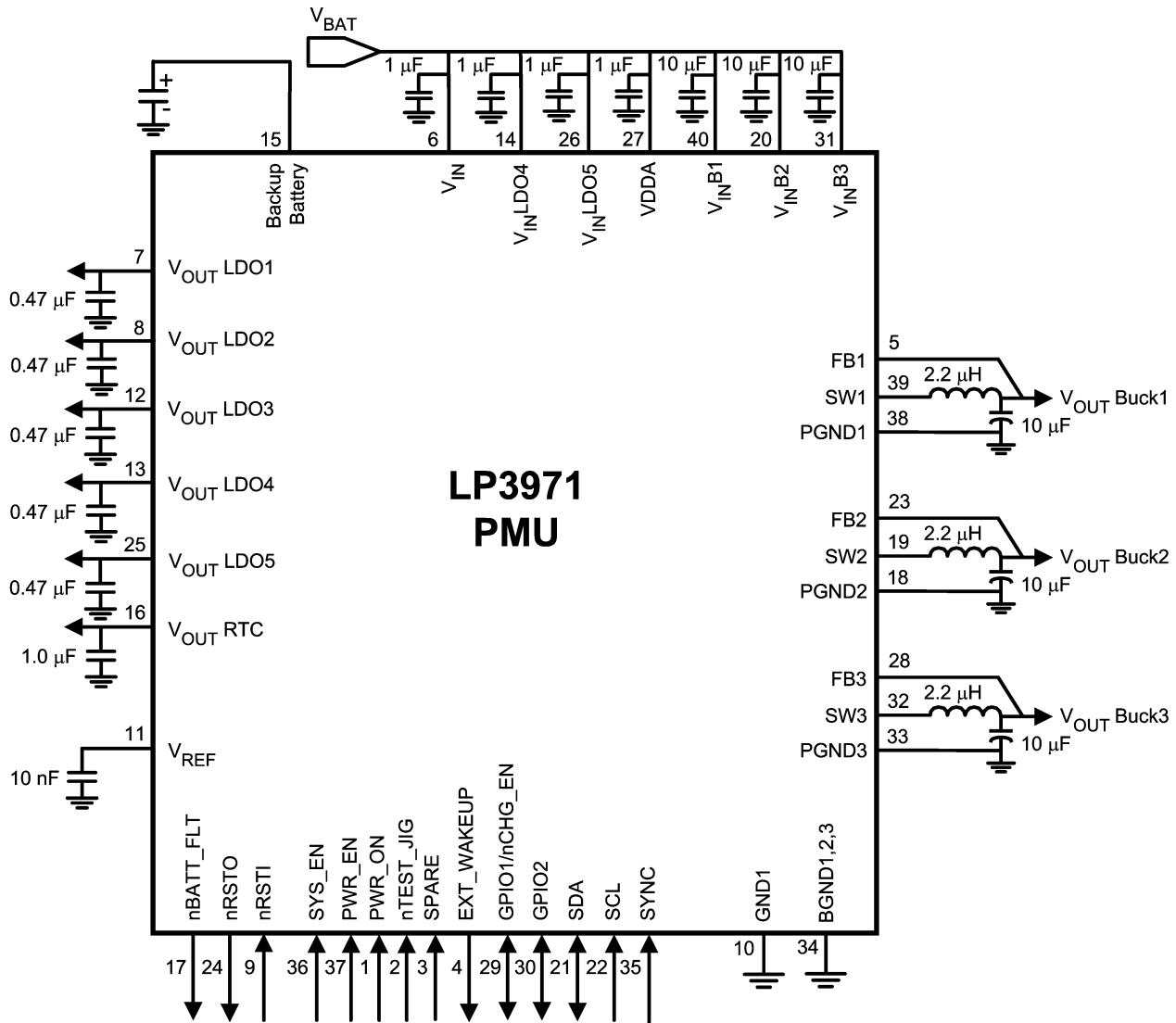

See Application Hints for recommended external components and component selection

20180706

\*\* NOTE: RTC LDO – In applications when V<sub>batt</sub> drops below 1.7V (ie. removing the main battery), system reset will be enabled. To void this situation, replace the RTC LDO (pin 16) 1.0uF capacitor with a 10uF capacitor.



# Applications Schematic Diagrams (Continued)

Diagram 2 LDO 4 and LDO5 Connected To 1.8V Supply

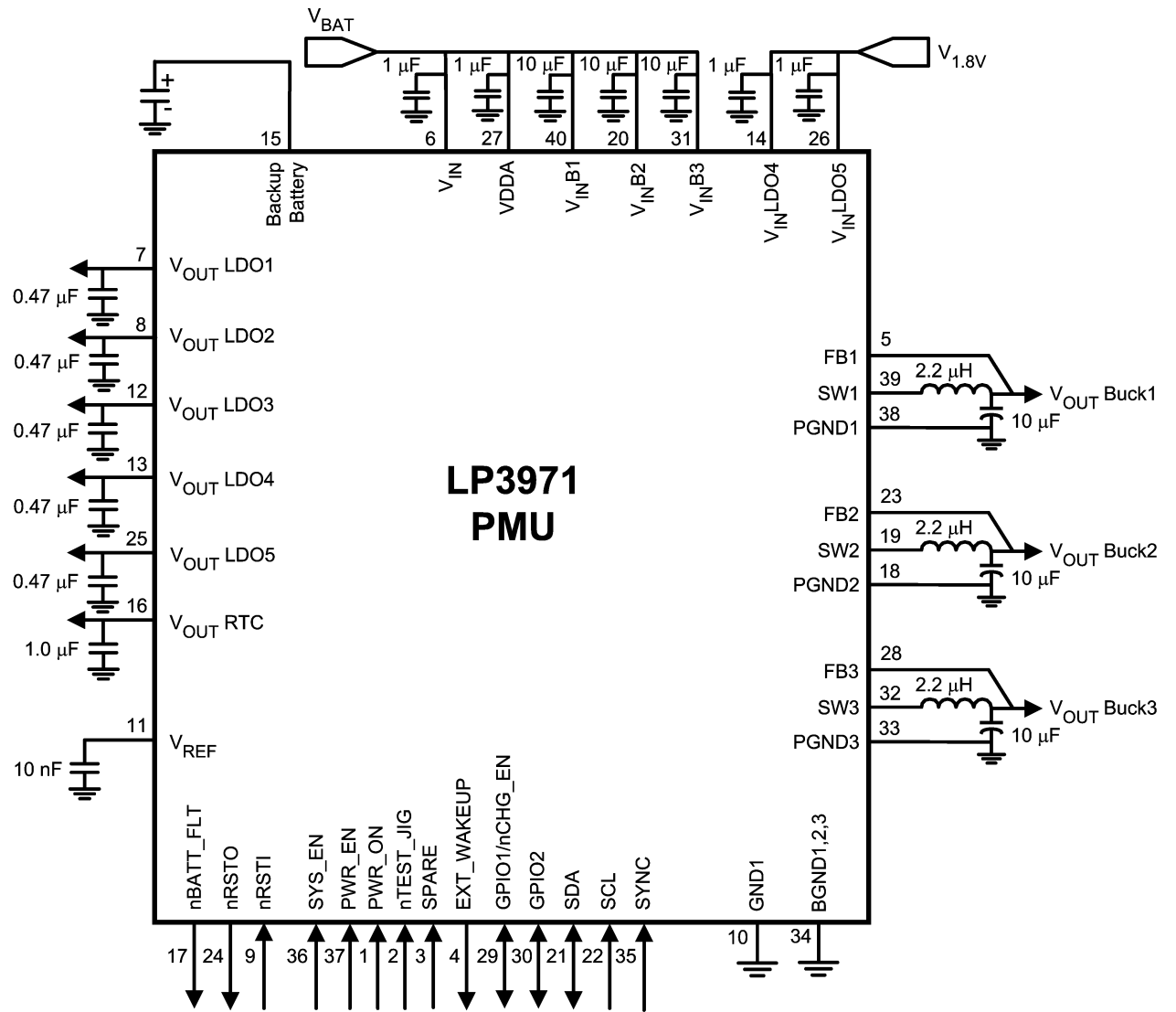

20180707



**Absolute Maximum Ratings** (Note 1)

If Military/Aerospace specified devices are required, please contact the National Semiconductor Sales Office/ Distributors for availability and specifications.

All Inputs	-0.3V to +6V
GND to GND SLUG	±0.3V
Junction Temperature ( $T_{J-MAX}$ )	150°C
Storage Temperature	-65°C to +150°C
Power Dissipation ( $T_A = 70^\circ\text{C}$ ) (Note 3)	3.2W
Junction-to-Ambient Thermal Resistance $\theta_{JA}$ (Note 3)	25°C/W
Maximum Lead Temp (Soldering)	260°C

## ESD Rating (Note 5)

Human Body Model	2 kV
Machine Model	200V

**Operating Ratings**

$V_{IN}$	2.7V to 5.5V
$V_{EN}$	0 to ( $V_{IN} + 0.3V$ )
Junction Temperature ( $T_J$ )	-40°C to +125°C
Operating Temperature ( $T_A$ )	-40°C to +85°C
Maximum Power Dissipation ( $T_A = 70^\circ\text{C}$ ) (Notes 3, 4)	2.2W

**General Electrical Characteristics** Typical values and limits appearing in normal type apply for  $T_J = 25^\circ\text{C}$ . Limits appearing in **boldface** type apply over the entire junction temperature range for operation, -40°C to +125°C. (Notes 2, 6)

Symbol	Parameter	Conditions	Min	Typ	Max	Units
$V_{IN}$ , VDDA, $V_{IN}$ Buck1, 2 and 3	Battery Voltage		<b>2.7</b>	3.6	<b>5.5</b>	V
$V_{IN}$ LDO4, $V_{IN}$ LDO5	Power Supply for LDO 4 and 5		<b>1.74</b>	3.6	<b>5.5</b>	V
$T_{SD}$	Thermal Shutdown (Note 14)	Temperature		160		°C
		Hysteresis		20		

\*\*No input supply should be higher than VDDA

**Supply Specification** (Notes 2, 6)

Supply	$V_{OUT}$ (Volts)		$I_{MAX}$ Maximum Output
	Range (V)	Resolution (mV)	Current (mA) (Note 14)
LDO_RTC	Tracking (Note 10)	N/A	<b>30 or 10</b>
LDO1	1.8 to 3.3	100	<b>300</b>
LDO2	1.8 to 3.3	100	<b>150</b>
LDO3	1.8 to 3.3	100	<b>150</b>
LDO4	1.0 to 3.3	50-600	<b>150</b>
LDO5	1.0 to 3.3	50-600	<b>370</b>
BUCK 1	0.8 to 3.3	50-600	<b>1600</b>
BUCK 2	0.8 to 3.3	50-600	<b>1600</b>
BUCK 3	0.8 to 3.3	50-600	<b>1600</b>

**Defaults** (Notes 2, 6)

Supply	'A' Version		'B' Version	
	(V)	Enable 'A'	(V)	Enable 'B'
LDO_RTC	<b>2.8</b>	...	<b>2.8</b>	...
LDO1	<b>1.8</b>	<b>SYS_EN</b>	<b>3.0</b>	<b>SYS_EN</b>
LDO2	<b>1.8</b>	<b>SYS_EN</b>	<b>3.0</b>	<b>SYS_EN</b>
LDO3	<b>3.0</b>	<b>SYS_EN</b>	<b>3.0</b>	<b>SYS_EN</b>
LDO4	<b>3.0</b>	<b>SYS_EN</b>	<b>1.3</b>	<b>PWR_EN</b>
LDO5	<b>1.4</b>	<b>PWR_EN</b>	<b>1.1</b>	<b>PWR_EN</b>
BUCK1	<b>1.4</b>	<b>PWR_EN</b>	<b>1.4</b>	<b>PWR_EN</b>
BUCK2	<b>3.3</b>	<b>SYS_EN</b>	<b>3.0</b>	<b>SYS_EN</b>
BUCK3	<b>1.8</b>	<b>SYS_EN</b>	<b>1.8</b>	<b>SYS_EN</b>

\*\*Version-A LDO Tracking Disabled, Version-B LDO Tracking Enabled



## LDO RTC

Unless otherwise noted,  $V_{IN} = 3.6V$ ,  $C_{IN} = 1.0 \mu F$ ,  $C_{OUT} = 0.47 \mu F$ ,  $C_{OUT} (V_{RTC}) = 1.0 \mu F$  ceramic. Typical values and limits appearing in normal type apply for  $T_J = 25^\circ C$ . Limits appearing in **boldface** type apply over the entire junction temperature range for operation,  $-40^\circ C$  to  $+125^\circ C$ . (Notes 2, 6, 7) and (Note 10)

Symbol	Parameter	Conditions	Min	Typ	Max	Units
$V_{OUT}$ Accuracy	Output Voltage Accuracy	$V_{IN}$ Connected, Load Current = 1 mA	<b>2.632</b>	2.8	<b>2.968</b>	V
$\Delta V_{OUT}$	Line Regulation	$V_{IN} = (V_{OUT} \text{ nom} + 1.0V)$ to 5.5V (Note 11) Load Current = 1 mA			<b>0.15</b>	%/V
	Load Regulation	From Main Battery Load Current = 1 mA to 30 mA			<b>0.05</b>	%mA
		From Backup Battery $V_{IN} = 3.0V$ Load Current = 1 mA to 10 mA			<b>0.5</b>	
$I_{SC}$	Short Circuit Current Limit	From Main Battery $V_{IN} = V_{OUT} + 0.3V$ to 5.5V		100		mA
		From Backup Battery		30		
$V_{IN} - V_{OUT}$	Dropout Voltage	Load Current = 10 mA			<b>375</b>	mV
$I_{Q\_Max}$	Maximum Quiescent Current	$I_{OUT} = 0$ mA		30		$\mu A$
TP1	RTC LDO Input Switched from Main Battery to Backup Battery	$V_{IN}$ Falling		2.9		V
TP2	RTC LDO Input Switched from Backup Battery to Main Battery	$V_{IN}$ Rising		3.0		V
$C_O$	Output Capacitor	Capacitance for Stability	<b>0.7</b>	1.0		$\mu F$
		ESR	<b>5</b>		<b>500</b>	m $\Omega$



## LDO 1 to 5

Unless otherwise noted,  $V_{IN} = 3.6V$ ,  $C_{IN} = 1.0 \mu F$ ,  $C_{OUT} = 0.47 \mu F$ ,  $C_{OUT} (V_{RTC}) = 1.0 \mu F$  ceramic. Typical values and limits appearing in normal type apply for  $T_J = 25^\circ C$ . Limits appearing in **boldface** type apply over the entire junction temperature range for operation,  $-40^\circ C$  to  $+125^\circ C$ . (Notes 2, 6, 7, 10, 11, 15) and (Note 16).

Symbol	Parameter	Conditions	Min	Typ	Max	Units
$V_{OUT}$ Accuracy	Output Voltage Accuracy (Default $V_{OUT}$ )	Load Current = 1 mA	<b>-3</b>		<b>3</b>	%
$\Delta V_{OUT}$	Line Regulation	$V_{IN} = 3.1V$ to $5.0V$ , (Note 11) Load Current = 1 mA			<b>0.15</b>	%/V
	Load Regulation	$V_{IN} = 3.6V$ , Load Current = 1 mA to $I_{MAX}$			<b>0.011</b>	%/mA
$I_{SC}$	Short Circuit Current Limit	LDO1-4, $V_{OUT} = 0V$		400		mA
		LDO5, $V_{OUT} = 0V$		500		
$V_{IN} - V_{OUT}$	Dropout Voltage	Load Current = 50 mA (Note 7)			<b>150</b>	mV
PSRR	Power Supply Ripple Rejection	$f = 10$ kHz, Load Current = $I_{MAX}$		45		dB
$I_Q$	Quiescent Current "On"	$I_{OUT} = 0$ mA		40		$\mu A$
	Quiescent Current "On"	$I_{OUT} = I_{MAX}$		60		
	Quiescent Current "Off"	EN is de-asserted		0.03		
$T_{ON}$	Turn On Time	Start up from Shut-down		300		$\mu sec$
$C_{OUT}$	Output Capacitor	Capacitance for Stability $0^\circ C \leq T_J \leq 125^\circ C$	<b>0.33</b>	0.47		$\mu F$
		$-40^\circ C \leq T_J \leq 125^\circ C$	<b>0.68</b>	1.0		
		ESR	<b>5</b>		<b>500</b>	M $\Omega$

## Buck Converters SW1, SW2, SW3

Unless otherwise noted,  $V_{IN} = 3.6V$ ,  $C_{IN} = 10 \mu F$ ,  $C_{OUT} = 10 \mu F$ ,  $L_{OUT} = 2.2 \mu H$  ceramic. Typical values and limits appearing in normal type apply for  $T_J = 25^\circ C$ . Limits appearing in **boldface** type apply over the entire junction temperature range for operation,  $-40^\circ C$  to  $+125^\circ C$ . (Notes 2, 6, 12) and (Note 13).

Symbol	Parameter	Conditions	Min	Typ	Max	Units
$V_{OUT}$	Output Voltage Accuracy	Default $V_{OUT}$	<b>-3</b>		<b>+3</b>	%
Eff	Efficiency	Load Current = 500 mA		90		%
$I_{SHDN}$	Shutdown Supply Current	EN is de-asserted		0.1		$\mu A$
	Sync Mode Clock Frequency	Synchronized from 13 MHz System Clock	10.4	13	15.6	MHz
$f_{OSC}$	Internal Oscillator Frequency			2.0		MHz
$I_{PEAK}$	Peak Switching Current Limit			2.1	2.4	A
$I_Q$	Quiescent Current "On"	No Load PFM Mode		21		$\mu A$
		No Load PWM Mode		200		
$R_{DS(ON)}$ (P)	Pin-Pin Resistance PFET			240		m $\Omega$
$R_{DS(ON)}$ (N)	Pin-Pin Resistance NFET			150		m $\Omega$
$T_{ON}$	Turn On Time	Start up from Shut-down		500		$\mu sec$
$C_{IN}$	Input Capacitor	Capacitance for Stability	8			$\mu F$
$C_O$	Output Capacitor	Capacitance for Stability	8			$\mu F$



## Back-Up Charger Electrical Characteristics

Unless otherwise noted,  $V_{IN} = V_{BATT} = 3.6V$ . Typical values and limits appearing in normal type apply for  $T_J = 25^\circ C$ . Limits appearing in **boldface** type apply over the entire junction temperature range for operation,  $-40^\circ C$  to  $+125^\circ C$ . (Notes 2, 6) and (Note 8).

Symbol	Parameter	Conditions	Min	Typ	Max	Units
$V_{IN}$	Operational Voltage Range	Voltage at $V_{IN}$	<b>3.3</b>		<b>5.5</b>	V
$I_{OUT}$	Backup Battery Charging Current	$V_{IN} = 3.6V$ , Backup_Bat = 2.5V, Backup Battery Charger Enabled (Note 8)		190		$\mu A$
$V_{OUT}$	Charger Termination Voltage	$V_{IN} = 5.0V$ Backup Battery Charger Enabled. Programmable	<b>2.91</b>	3.1		V
	Backup Battery Charger Short Circuit Current	Backup_Bat = 0V, Backup Battery Charger Enabled		9		mA
PSRR	Power Supply Ripple Rejection Ratio	$I_{OUT} \leq 50 \mu A$ , $V_{OUT} = 3.15V$ $V_{OUT} + 0.4 \leq V_{BATT} = V_{IN} \leq 5.0V$ $f < 10 \text{ kHz}$		15		dB
$I_Q$	Quiescent Current	$I_{OUT} < 50 \mu A$		25		$\mu A$
$C_{OUT}$	Output Capacitance	$0 \mu A \leq I_{OUT} \leq 100 \mu A$		0.1		$\mu F$
	Output Capacitor ESR		<b>5</b>		<b>500</b>	M $\Omega$

## Logic Inputs and Outputs DC Operating Conditions (Note 2)

Logic Inputs (SYS\_EN, PWR\_EN, SYNC, nRSTI, PWR\_ON, nTEST\_JIG, SPARE and GPI's)

Symbol	Parameter	Conditions	Min	Max	Units
$V_{IL}$	Low Level Input Voltage			<b>0.5</b>	V
$V_{IH}$	High Level Input Voltage		$V_{RTC}$ <b>-0.5V</b>		V
$I_{LEAK}$	Input Leakage Current		<b>-1</b>	<b>+1</b>	$\mu A$

Logic Outputs (nRSTO, EXT\_WAKEUP and GPO's)

Symbol	Parameter	Conditions	Min	Max	Units
$V_{OL}$	Output Low Level	Load = +0.2 mA = $I_{OL}$ Max		<b>0.5</b>	V
$V_{OH}$	Output High Level	Load = -0.1 mA = $I_{OL}$ Max	$V_{RTC}$ <b>-0.5V</b>		V
$I_{LEAK}$	Output Leakage Current	$V_{ON} = V_{IN}$		<b>+5</b>	$\mu A$

Logic Output (nBATT\_FLT)

Symbol	Parameter	Conditions	Min	Typ	Max	Units
	nBATT_FLT Threshold Voltage	Programmable via Serial Interface Default = 2.8V	<b>2.4</b>	2.8	<b>3.4</b>	V
$V_{OL}$	Output Low Level	Load = +0.4 mA = $I_{OL}$ Max			<b>0.5</b>	V
$V_{OH}$	Output High Level	Load = -0.2 mA = $I_{OH}$ Max	$V_{RTC}$ <b>-0.5V</b>			V
$I_{LEAK}$	Input Leakage Current				<b>+5</b>	$\mu A$



## I<sup>2</sup>C Compatible Serial Interface Electrical Specifications (SDA and SCL)

Unless otherwise noted,  $V_{IN} = 3.6V$ . Typical values and limits appearing in normal type apply for  $T_J = 25^\circ C$ . Limits appearing in **boldface** type apply over the entire junction temperature range for operation,  $-40^\circ C$  to  $+125^\circ C$ . (Notes 2, 6) and (Note 9)

Symbol	Parameter	Conditions	Min	Typ	Max	Units
$V_{IL}$	Low Level Input Voltage	(Note 14)	-0.5		$0.3 V_{RTC}$	V
$V_{IH}$	High Level Input Voltage	(Note 14)	$0.7 V_{RTC}$		$V_{RTC}$	
$V_{OL}$	Low Level Output Voltage	(Note 14)	0		$0.2 V_{TRC}$	
$I_{OL}$	Low Level Output Current	$V_{OL} = 0.4V$ (Note 14)	3.0			mA
$F_{CLK}$	Clock Frequency	(Note 14)			400	kHz
$t_{BF}$	Bus-Free Time Between Start and Stop	(Note 14)	1.3			$\mu s$
$t_{HOLD}$	Hold Time Repeated Start Condition	(Note 14)	0.6			$\mu s$
$t_{CLKLP}$	CLK Low Period	(Note 14)	1.3			$\mu s$
$t_{CLKHP}$	CLK High Period	(Note 14)	0.6			$\mu s$
$t_{SU}$	Set Up Time Repeated Start Condition	(Note 14)	0.6			$\mu s$
$t_{DATAHLD}$	Data Hold Time	(Note 14)	0			$\mu s$
$t_{CLKSU}$	Data Set Up Time	(Note 14)	100			ns
$T_{SU}$	Set Up Time for Start Condition	(Note 14)	0.6			$\mu s$
$T_{TRANS}$	Maximum Pulse Width of Spikes that Must be Suppressed by the Input Filter of Both DATA & CLK Signals	(Note 14)		50		ns

**Note 1:** Absolute Maximum Ratings are limits beyond which damage to the device may occur. Operating Ratings are conditions under which operation of the device is guaranteed. Operating Ratings do not imply guaranteed performance limits. For guaranteed performance limits and associated test conditions, see the Electrical Characteristics tables.

**Note 2:** All voltages are with respect to the potential at the GND pin.

**Note 3:** In applications where high power dissipation and/or poor package thermal resistance is present, the maximum ambient temperature may have to be derated. Maximum ambient temperature (TA-MAX) is dependent on the maximum operating junction temperature ( $T_{J-MAX-OP} = 125^\circ C$ ), the maximum power dissipation of the device in the application (PD-MAX), and the junction-to ambient thermal resistance of the part/package in the application ( $\theta_{JA}$ ), as given by the following equation:  $TA-MAX = T_{J-MAX-OP} - (\theta_{JA} \times PD-MAX)$ .

**Note 4:** Junction-to-ambient thermal resistance ( $\theta_{JA}$ ) is taken from a thermal modeling result, performed under the conditions and guidelines set forth in the JEDEC standard JESD51-7. The test board is a 4-layer FR-4 board measuring 102 mm x 76 mm x 1.6 mm with a 2x1 array of thermal vias. The ground plane on the board is 50 mm x 50 mm. Thickness of copper layers are 36  $\mu m$ /1.8  $\mu m$ /18  $\mu m$ /36  $\mu m$  (1.5 oz/1 oz/1 oz/1.5 oz). Ambient temperature in simulation is 22°C, still air. Power dissipation is 1W. Junction-to-ambient thermal resistance is highly application and board-layout dependent. In applications where high maximum power dissipation exists, special care must be paid to thermal dissipation issues in board design. The value of  $\theta_{JA}$  of this product can vary significantly, depending on PCB material, layout, and environmental conditions. In applications where high maximum power dissipation exists (high  $V_{IN}$ , high  $I_{OUT}$ ), special care must be paid to thermal dissipation issues. For more information on these topics, please refer to *Application Note 1187: Leadless Leadframe Package (LLP) and the Power Efficiency and Power Dissipation* section of this datasheet.

**Note 5:** The Human body model is a 100 pF capacitor discharged through a 1.5 k $\Omega$  resistor into each pin. (MIL-STD-883 3015.7). The machine model is a 200 pF capacitor discharged directly into each pin. (EAIJ)

**Note 6:** All limits guaranteed at room temperature (standard typeface) and at temperature extremes (bold typeface). All room temperature limits are production tested, guaranteed through statistical analysis or guaranteed by design. All limits at temperature extremes are guaranteed via correlation using standard Statistical Quality Control (SQC) methods. All limits are used to calculate Average Outgoing Quality Level (AOQL).

**Note 7:** Dropout voltage is the input-to-output voltage difference at which the output voltage is 100 mV below its nominal value.

**Note 8:** Back-up battery charging current is programmable via the I<sup>2</sup>C compatible interface. Refer to the Application Section for more information.

**Note 9:** The I<sup>2</sup>C signals behave like open-drain outputs and require an external pull-up resistor on the system module in the 2 k $\Omega$  to 20 k $\Omega$  range.

**Note 10:** LDO\_RTC voltage can track LDO1 (I/O) Voltage. Refer to LP3971 Controls Section for more information.

**Note 11:**  $V_{IN}$  minimum for line regulation values is 2.7V for LDOs 1–3 and 1.8V for LDOs 4 and 5. Condition does not apply to input voltages below the minimum input operating voltage.

**Note 12:** The input voltage range recommended for ideal applications performance for the specified output voltages is given below:

$$V_{IN} = 2.7V \text{ to } 5.5V \text{ for } 0.80V < V_{OUT} < 1.8V$$

$$V_{IN} = (V_{OUT} + 1V) \text{ to } 5.5V \text{ for } 1.8V \leq V_{OUT} \leq 3.3V$$

**Note 13:** Test condition: for  $V_{OUT}$  less than 2.7V,  $V_{IN} = 3.6V$ ; for  $V_{OUT}$  greater than or equal to 2.7V,  $V_{IN} = V_{OUT} + 1V$ .

**Note 14:** This electrical specification is guaranteed by design.

**Note 15:** An increase in the load current results in a slight decrease in the output voltage and vice versa.

**Note 16:** Dropout voltage is the input-to-output voltage difference at which the output voltage is 100 mV below its nominal value. This specification does not apply for input voltages below 2.7V for LDOs 1–3 and 1.8V for LDOs 4 and 5.



# Input Test Signals

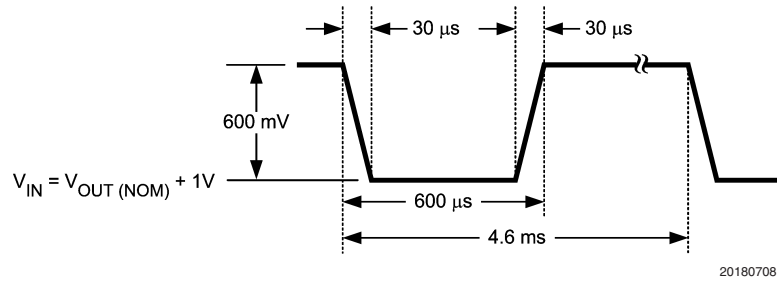

20180708

**FIGURE 1. Line Transient Response Input Test Signal**

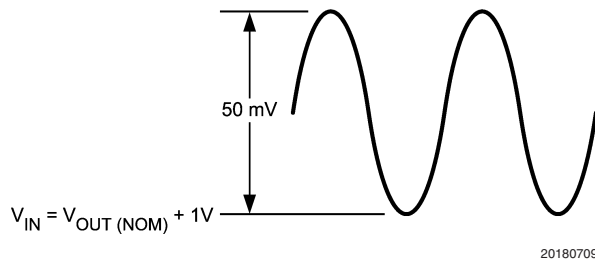

20180709

**FIGURE 2. PSRR Input Test Signal**



# Functional Block Diagram

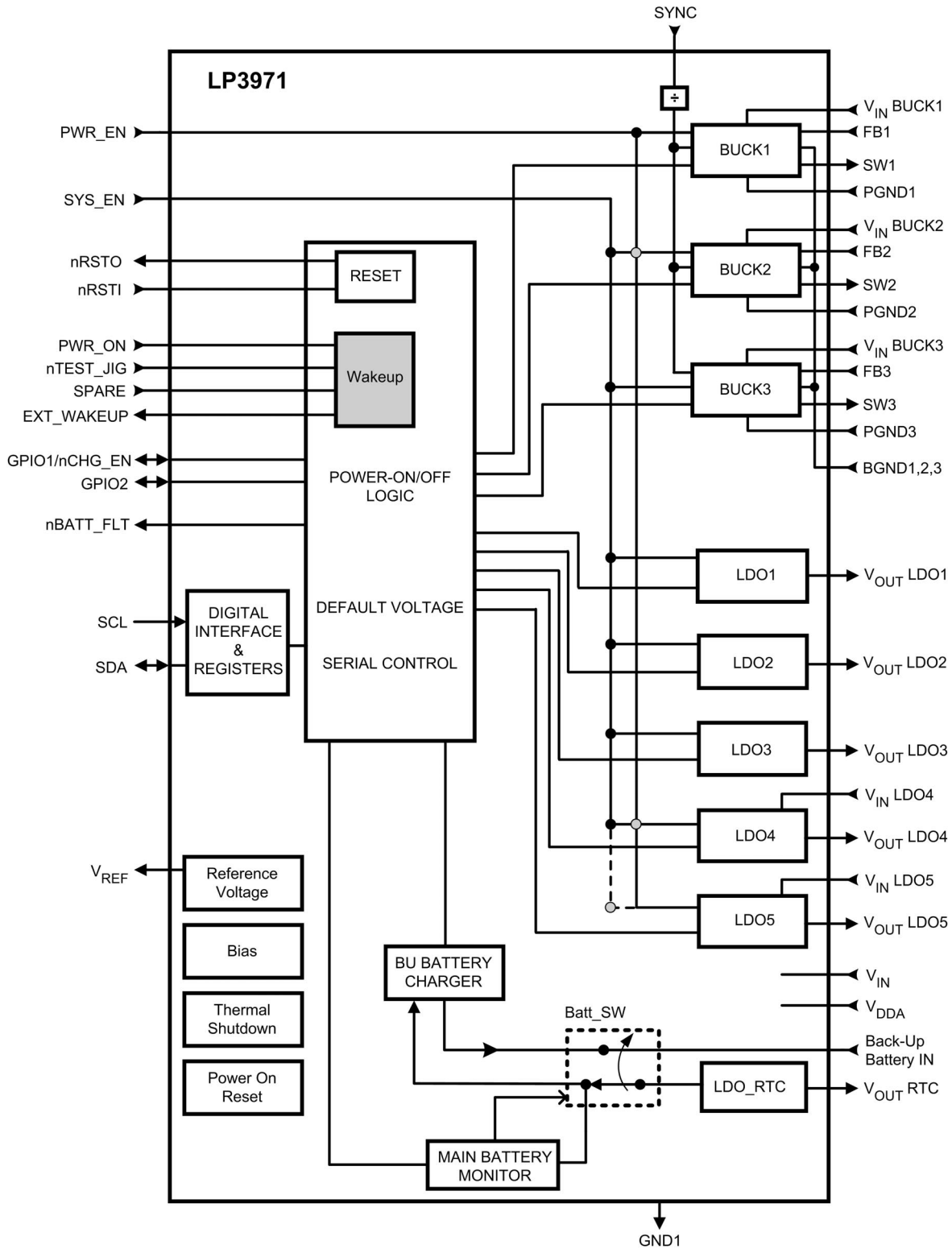

20180710



## Buck Converter Operation

### DEVICE INFORMATION

The LP3971 includes three high efficiency step down DC-DC switching buck converters. Using a voltage mode architecture with synchronous rectification, the buck converters have the ability to deliver up to 1600 mA depending on the input voltage, output voltage, ambient temperature and the inductor chosen. There are three modes of operation depending on the current required - PWM, PFM, and shutdown. The device operates in PWM mode at load currents of approximately 100 mA or higher, having voltage tolerance of  $\pm 3\%$  with 95% efficiency or better. Lighter load currents cause the device to automatically switch into PFM for reduced current consumption. Shutdown mode turns off the device, offering the lowest current consumption ( $I_{Q, \text{SHUTDOWN}} = 0.01 \mu\text{A}$  typ). Additional features include soft-start, under voltage protection, current overload protection, and thermal shutdown protection. The part uses an internal reference voltage of 0.5V. It is recommended to keep the part in shutdown until the input voltage is 2.8V or higher.

### CIRCUIT OPERATION

The buck converter operates as follows. During the first portion of each switching cycle, the control block turns on the internal PFET switch. This allows current to flow from the input through the inductor to the output filter capacitor and load. The inductor limits the current to a ramp with a slope of  $(V_{\text{IN}} - V_{\text{OUT}})/L$ , by storing energy in a magnetic field.

During the second portion of each cycle, the controller turns the PFET switch off, blocking current flow from the input, and then turns the NFET synchronous rectifier on. The inductor draws current from ground through the NFET to the output filter capacitor and load, which ramps the inductor current down with a slope of  $-V_{\text{OUT}}/L$ .

The output filter stores charge when the inductor current is high, and releases it when inductor current is low, smoothing the voltage across the load.

The output voltage is regulated by modulating the PFET switch on time to control the average current sent to the load. The effect is identical to sending a duty-cycle modulated rectangular wave formed by the switch and synchronous rectifier at the SW pin to a low-pass filter formed by the inductor and output filter capacitor. The output voltage is equal to the average voltage at the SW pin.

### PWM OPERATION

During PWM operation the converter operates as a voltage mode controller with input voltage feed forward. This allows the converter to achieve good load and line regulation. The DC gain of the power stage is proportional to the input voltage. To eliminate this dependence, feed forward inversely proportional to the input voltage is introduced.

While in PWM (Pulse Width Modulation) mode, the output voltage is regulated by switching at a constant frequency and then modulating the energy per cycle to control power to the load. At the beginning of each clock cycle the PFET switch is turned on and the inductor current ramps up until the comparator trips and the control logic turns off the switch. The current limit comparator can also turn off the switch in case the current limit of the PFET is exceeded. Then the NFET switch is turned on and the inductor current ramps down. The next cycle is initiated by the clock turning off the NFET and turning on the PFET.

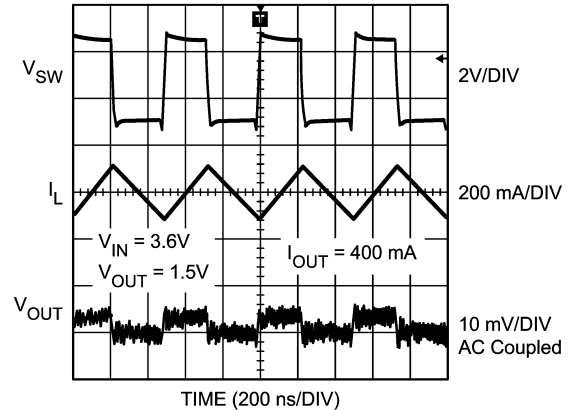

20180711

FIGURE 3. Typical PWM Operation

### Internal Synchronous Rectification

While in PWM mode, the converters uses an internal NFET as a synchronous rectifier to reduce rectifier forward voltage drop and associated power loss. Synchronous rectification provides a significant improvement in efficiency whenever the output voltage is relatively low compared to the voltage drop across an ordinary rectifier diode.

### Current Limiting

A current limit feature allows the converters to protect itself and external components during overload conditions. PWM mode implements current limiting using an internal comparator that trips at 2.1A (typ). If the output is shorted to ground the device enters a timed current limit mode where the NFET is turned on for a longer duration until the inductor current falls below a low threshold, ensuring inductor current has more time to decay, thereby preventing runaway.

### PFM OPERATION

At very light loads, the converter enters PFM mode and operates with reduced switching frequency and supply current to maintain high efficiency.

The part will automatically transition into PFM mode when either of two conditions occurs for a duration of 32 or more clock cycles:

- A: The inductor current becomes discontinuous.
- B: The peak PMOS switch current drops below the  $I_{\text{MODE}}$  level, (Typically  $I_{\text{MODE}} < 30 \text{ mA} + V_{\text{IN}}/42\Omega$ ).



## Buck Converter Operation (Continued)

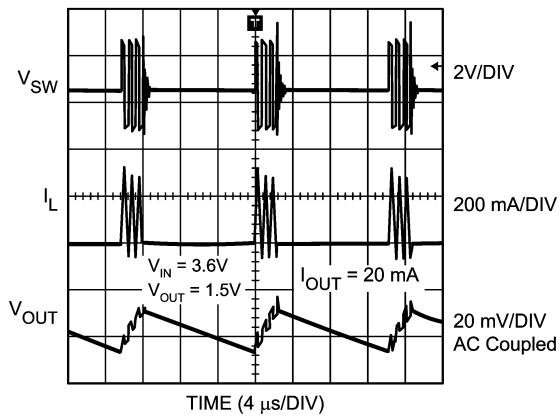

20180712

**FIGURE 4. Typical PFM Operation**

During PFM operation, the converter positions the output voltage slightly higher than the nominal output voltage during PWM operation, allowing additional headroom for voltage drop during a load transient from light to heavy load. The PFM comparators sense the output voltage via the feedback pin and control the switching of the output FETs such that the output voltage ramps between <0.6% and <1.7% above the

nominal PWM output voltage. If the output voltage is below the “high” PFM comparator threshold, the PMOS power switch is turned on. It remains on until the output voltage reaches the ‘high’ PFM threshold or the peak current exceeds the IPFM level set for PFM mode. The typical peak current in PFM mode is:  $I_{PFM} = 112 \text{ mA} + V_{IN}/27\Omega$ . Once the PMOS power switch is turned off, the NMOS power switch is turned on until the inductor current ramps to zero. When the NMOS zero-current condition is detected, the NMOS power switch is turned off. If the output voltage is below the ‘high’ PFM comparator threshold (see Figure 5), the PMOS switch is again turned on and the cycle is repeated until the output reaches the desired level. Once the output reaches the ‘high’ PFM threshold, the NMOS switch is turned on briefly to ramp the inductor current to zero and then both output switches are turned off and the part enters an extremely low power mode. Quiescent supply current during this ‘sleep’ mode is 16  $\mu\text{A}$  (typ), which allows the part to achieve high efficiencies under extremely light load conditions. When the output drops below the ‘low’ PFM threshold, the cycle repeats to restore the output voltage (average voltage in PFM mode) to <1.15% above the nominal PWM output voltage. If the load current should increase during PFM mode (see Figure 5) causing the output voltage to fall below the ‘low2’ PFM threshold, the part will automatically transition into fixed-frequency PWM mode. Typically when  $V_{IN} = 3.6\text{V}$  the part transitions from PWM to PFM mode at 100 mA output current.

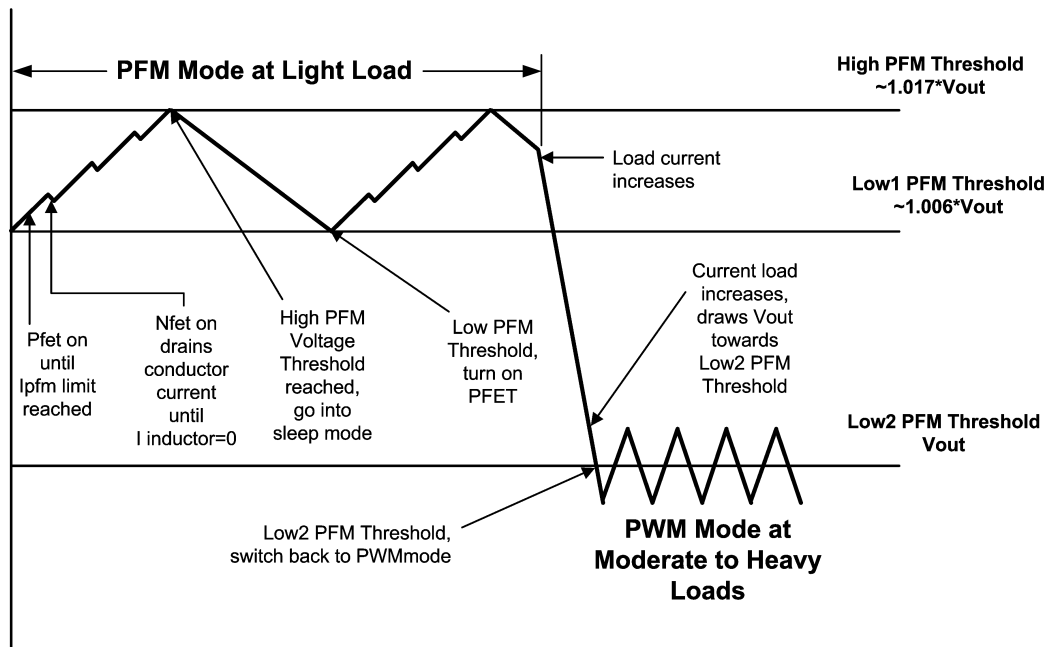

20180713

**FIGURE 5. Operation in PFM Mode and Transfer to PWM Mode**



## Buck Converter Operation (Continued)

### SHUTDOWN MODE

During shutdown the PFET switch, reference, control and bias circuitry of the converters are turned off. The NFET switch will be on in shutdown to discharge the output. When the converter is enabled, soft start is activated. It is recommended to disable the converter during the system power up and undervoltage conditions when the supply is less than 2.8V.

### SOFT START

The buck converter has a soft-start circuit that limits in-rush current during start-up. During start-up the switch current limit is increased in steps. Soft start is activated only if EN goes from logic low to logic high after  $V_{IN}$  reaches 2.8V. Soft start is implemented by increasing switch current limit in steps of 213 mA, 425 mA, 850 mA and 1700 mA (typ. Switch current limit). The start-up time thereby depends on the output capacitor and load current demanded at start-up. Typical start-up times with 10  $\mu$ F output capacitor and 1000 mA load current is 390  $\mu$ s and with 1 mA load current its 295  $\mu$ s.

### LDO - LOW DROP OUT OPERATION

The LP3971 can operate at 100% duty cycle (no switching; PMOS switch completely on) for low drop out support of the output voltage. In this way the output voltage will be controlled down to the lowest possible input voltage. When the device operates near 100% duty cycle, output voltage ripple is approximately 25 mV. The minimum input voltage needed to support the output voltage is

$$V_{IN, MIN} = I_{LOAD} * (R_{DSON, PFET} + R_{INDUCTOR}) + V_{OUT}$$

- $I_{LOAD}$  Load Current
- $R_{DSON, PFET}$  Drain to source resistance of PFET switch in the triode region
- $R_{INDUCTOR}$  Inductor resistance

### BUCK CONVERTER EFFICIENCY

$V_{IN}$ (V)	$V_{OUT}$ (V)	$I_{OUT}$ (mA)	EFF(%)
3.6	1.4	100	85
3.6	1.4	500	89
3.6	1.4	1000	84
3.6	1.4	1500	78

$V_{IN}$ (V)	$V_{OUT}$ (V)	$I_{OUT}$ (mA)	EFF(%)
3.6	3.3	100	92
3.6	3.3	500	96
3.6	3.3	1000	93
3.6	3.3	1500	90

$V_{IN}$ (V)	$V_{OUT}$ (V)	$I_{OUT}$ (mA)	EFF(%)
3.6	1.8	100	85
3.6	1.8	500	91
3.6	1.8	1000	87
3.6	1.8	1500	82

## I<sup>2</sup>C Compatible Interface

### I<sup>2</sup>C DATA VALIDITY

The data on SDA line must be stable during the HIGH period of the clock signal (SCL). In other words, state of the data line can only be changed when CLK is LOW.

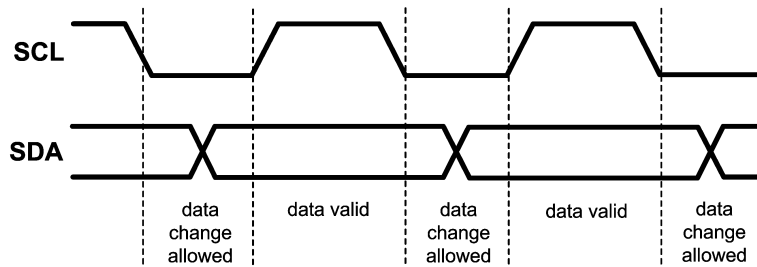

20180714

### I<sup>2</sup>C START and STOP CONDITIONS

START and STOP bits classify the beginning and the end of the I<sup>2</sup>C session. START condition is defined as SDA signal transitioning from HIGH to LOW while SCL line is HIGH. STOP condition is defined as the SDA transitioning from LOW to HIGH while SCL is HIGH. The I<sup>2</sup>C master always

generates START and STOP bits. The I<sup>2</sup>C bus is considered to be busy after START condition and free after STOP condition. During data transmission, I<sup>2</sup>C master can generate repeated START conditions. First START and repeated START conditions are equivalent, function-wise.





## I<sup>2</sup>C Compatible Interface (Continued)

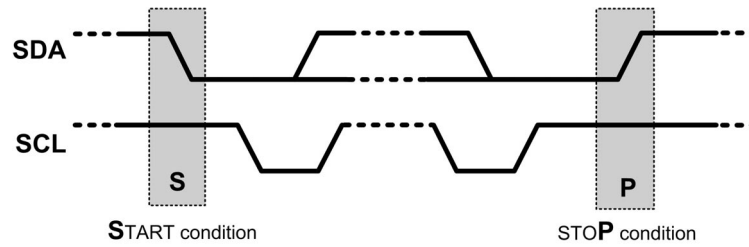

20180715

### TRANSFERRING DATA

Every byte put on the SDA line must be eight bits long, with the most significant bit (MSB) being transferred first. The number of bytes that can be transmitted per transfer is unrestricted. Each byte of data has to be followed by an acknowledge bit. The acknowledge related clock pulse is generated by the master. The transmitter releases the SDA line (HIGH) during the acknowledge clock pulse. The receiver must pull down the SDA line during the 9th clock pulse, signifying an acknowledge. A receiver which has been addressed must generate an acknowledge after each byte has been received.

After the START condition, a chip address is sent by the I<sup>2</sup>C master. This address is seven bits long followed by an eighth bit which is a data direction bit (R/W). The LP3971 address is 34h. For the eighth bit, a "0" indicates a WRITE and a "1" indicates a READ. The second byte selects the register to which the data will be written. The third byte contains data to write to the selected register.

### I<sup>2</sup>C CHIP ADDRESS - 7h'34

MSB	ADR6	ADR5	ADR4	ADR3	ADR2	ADR1	ADR0	R/W
Bit7	Bit6	Bit5	Bit4	Bit3	Bit2	Bit1	Bit0	Bit0
0	1	1	0	1	0	0	0	R/W

#### Write Cycle

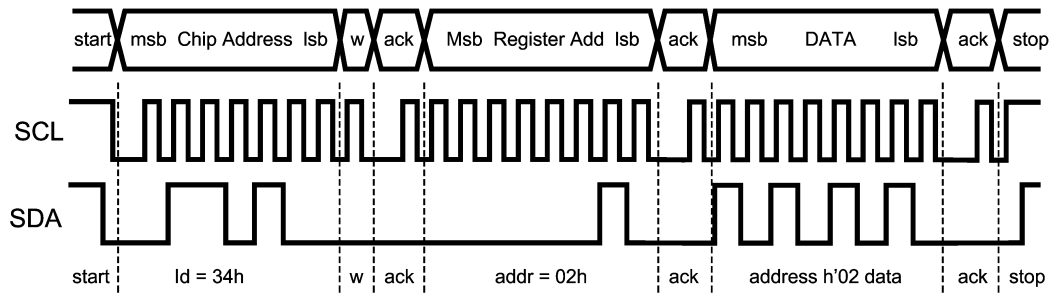

20180716

When a READ function is to be accomplished, a WRITE function must precede the READ function as follows.

#### Read Cycle

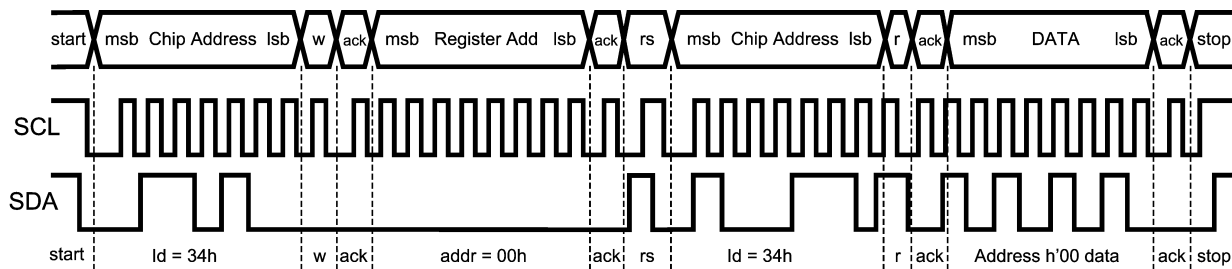

20180717

w = write (SDA = "0")

r = read (SDA = "1")

ack = acknowledge (SDA pulled down by either master or slave)

rs = repeated start

id = 34h (Chip Address)



## I<sup>2</sup>C Register Definitions

### I<sup>2</sup>C CONTROL REGISTERS

Register Address	Register Name	Read/Write	Register Description
8h'02	ISR	R	Interrupt Status Register A
8h'07	SCR1	R/W	System Control Register 1
8h'0B	BBCC	R/W	Backup Battery Charger Control Register
8h'0E	SCR2	R/W	System Control Register 2
8h'10	BOVEN	R/W	Buck Output Voltage Enable Register
8h'11	BOVSR	R	Buck Output Voltage Status Register
8h'12	LDOEN	R/W	LDO Output Voltage Enable Register
8h'13	LDOVS	R	LDO Output Voltage Status Register
8h'20	VCC1	R/W	Voltage Change Control Register 1
8h'23	B1TV1	R/W	Buck 1 Target Voltage 1 Register
8h'24	B1TV2	R/W	Buck 1 Target Voltage 2 Register
8h'25	B1RC	R/W	Buck 1 Ramp Control
8h'29	B2TV1	R/W	Buck 2 Target Voltage 1 Register
8h'2A	B2TV2	R/W	Buck 2 Target Voltage 2 Register
8h'2B	B2RC	R/W	Buck 2 Voltage Ramp Control
8h'32	B3TV1	R/W	Buck 3 Target Voltage 1 Register
8h'33	B3TV2	R/W	Buck 3 Target Voltage 2 Register
8h'34	B3RC	R/W	Buck 3 Voltage Ramp Control
8h'38	BFR	R/W	Buck Function Register
8h'39	L21VCR	R/W	LDO2 & 1 Voltage Control Registers
8h'3A	L43VCR	R/W	LDO4 & LDO3 Voltage Control Registers
8h'3B	L5VCR	R/W	LDO5 Voltage Control Registers

### INTERRUPT STATUS REGISTER (ISR) 8h'02

Bit	7	6	5	4	3	2	1	0
Designation	T100	T125	GPI2	GPI1	WU3L	WUPS	WUPT	WUPS
Reset Value	0	0	0	0	0	0	0	0

### INTERRUPT STATUS REGISTER (ISR) 8h'02 DEFINITIONS

Bit	Access	Name	Description
7	-	-	Reserved
6	R	T125	Status bit for thermal warning PMIC T>125°C 0 = PMIC Temp. <125°C 1 = PMIC Temp. >125°C
5	R	GPI2	Status bit for the input read in from GPIO 2 when set as Input 0 = GPI2 Logic Low 1 = GPI2 Logic High
4	R	GPI1	Status bit for the input read in from GPIO 1 when set as Input 0 = GPI1 Logic Low 1 = GPI1 Logic High
3	R	WU3L	PWR_ON Pin Long Pulse Wake Up Status 0 = 1 No wake up event 1 = Long pulse wake up event
2	R	WUPS	PWR_ON Pin Short Pulse Wake Up Status 0 = No wake up event 1 = Short pulse wake up event



## I<sup>2</sup>C Register Definitions (Continued)

Bit	Access	Name	Description
1	R	WUPT	TEST_JIG Pin Wake Up Status 0 = No wake up event 1 = Wake up event
0	R	WUPS	SPARE Pin Wake Up Status 0 = No wake up event 1 = Wake up event

### SYSTEM CONTROL REGISTER 1 (SCR1) 8h'07

Bit	7	6	5	4	3	2	1	0
Designation	BPSEN	Reserved	SENDL**		FPWM3	FPWM2	FPWM1	ECEN
Reset Value	0	1	1**	0**	0	0	0	0

Note: \*\* denotes EPROM programmable registers for default value.

### SYSTEM CONTROL REGISTER 1 (SCR1) 8h'07 DEFINITIONS

Bit	Access	Name	Description															
7	R/W	BPSEN	Bypass System enable safety Lock. Prevents activation of PWR_EN when SYS_EN is low. 0 = PWR_EN "AND" with SYS_EN signal 1 = PWR_EN independent of SYS_EN															
6	-	-	Reserved															
5:4	R/W	SENDL	Delay time for High Voltage Power Domains LDO2, LDO3, LDO4, Buck2, and Buck3 after activation of SYS_EN. VCC_LDO1 has no delay.  <table border="1"> <thead> <tr> <th>Data Code</th> <th>Delay mS</th> <th>Notes</th> </tr> </thead> <tbody> <tr> <td>2h'0</td> <td>0.0</td> <td></td> </tr> <tr> <td>2h'1</td> <td>0.5</td> <td></td> </tr> <tr> <td><b>2h'2</b></td> <td><b>1.0</b></td> <td>Default</td> </tr> <tr> <td>2h'3</td> <td>1.4</td> <td></td> </tr> </tbody> </table>	Data Code	Delay mS	Notes	2h'0	0.0		2h'1	0.5		<b>2h'2</b>	<b>1.0</b>	Default	2h'3	1.4	
Data Code	Delay mS	Notes																
2h'0	0.0																	
2h'1	0.5																	
<b>2h'2</b>	<b>1.0</b>	Default																
2h'3	1.4																	
3	R/W	FPWM3	Buck 3 PWM/PFM Mode Select 0 - Auto Switch between PFM and PWM operation 1 - PWM Mode Only will not switch to PFM															
2	R/W	FPWM2	Buck 2 PWM/PFM Mode Select 0 - Auto Switch between PFM and PWM operation 1 - PWM Mode Only will not switch to PFM															
1	R/W	FPWM1	Buck 1 PWM/PFM Mode Select 0 - Auto Switch between PFM and PWM operation 1 - PWM Mode Only will not switch to PFM															
0	R/W	ECEN	External Clock Select 0 = Internal Oscillator clock for Buck Converters 1 = External 13 MHz Oscillator clock for Buck Converters															



## I<sup>2</sup>C Register Definitions (Continued)

### BACKUP BATTERY CHARGER CONTROL REGISTER (BBCC) 8h'0B

Bit	7	6	5	4	3	2	1	0
Designation	NBUB	CNBFL	nBFLT			BUCEN	IBUC	
Reset Value	0	0	0	1	0	0	0	1

### BACKUP BATTERY CHARGER CONTROL REGISTER (BBCC) 8h'0B DEFINITIONS

Bit	Access	Name	Description																					
7	R/W	NBUB	No back-up battery default setting. Logic will not allow switch over to back-up battery. 0 = Back up Battery Enabled 1 = Back up Battery Disabled																					
6	R/W	CNBFL	Control for nBATT_FLT output signal 0 = nBATT_FLT Enabled 1 = nBATT_FLT Disabled																					
5:3	R/W	BFLT	nBATT_FLT monitors the battery voltage and can be set to the De-assert voltages listed below. <table border="1"> <thead> <tr> <th>Data Code</th> <th>Asserted</th> <th>De-Asserted</th> </tr> </thead> <tbody> <tr> <td>3h'00</td> <td>2.4</td> <td>2.6</td> </tr> <tr> <td>3h'01</td> <td>2.6</td> <td>2.8</td> </tr> <tr> <td>3h'02</td> <td><b>2.8</b></td> <td><b>3.0</b></td> </tr> <tr> <td>3h'03</td> <td>3.0</td> <td>3.2</td> </tr> <tr> <td>3h'04</td> <td>3.2</td> <td>3.4</td> </tr> <tr> <td>3h'05</td> <td>3.4</td> <td>3.6</td> </tr> </tbody> </table>	Data Code	Asserted	De-Asserted	3h'00	2.4	2.6	3h'01	2.6	2.8	3h'02	<b>2.8</b>	<b>3.0</b>	3h'03	3.0	3.2	3h'04	3.2	3.4	3h'05	3.4	3.6
Data Code	Asserted	De-Asserted																						
3h'00	2.4	2.6																						
3h'01	2.6	2.8																						
3h'02	<b>2.8</b>	<b>3.0</b>																						
3h'03	3.0	3.2																						
3h'04	3.2	3.4																						
3h'05	3.4	3.6																						
2	R/W	BUCEN	Enables backup battery charger 0 = Back up Battery Charger Disabled 1 = Back up Battery Charger Enabled																					
1:0	R/W	IBUC	Charger current setting for back-up battery <table border="1"> <thead> <tr> <th>Data Code</th> <th>BU Charger I (µA)</th> </tr> </thead> <tbody> <tr> <td>2h'00</td> <td>260</td> </tr> <tr> <td><b>2h'01</b></td> <td><b>190</b></td> </tr> <tr> <td>2h'02</td> <td>325</td> </tr> <tr> <td>2h'03</td> <td>390</td> </tr> </tbody> </table>	Data Code	BU Charger I (µA)	2h'00	260	<b>2h'01</b>	<b>190</b>	2h'02	325	2h'03	390											
Data Code	BU Charger I (µA)																							
2h'00	260																							
<b>2h'01</b>	<b>190</b>																							
2h'02	325																							
2h'03	390																							



## I<sup>2</sup>C Register Definitions (Continued)

### SYSTEM CONTROL REGISTER (SCR2) 8h'0E

Bit	7	6	5	4	3	2	1	0
Designation	BBCS	SEB2	BPTR**	WUP3_ sense	GPIO2		GPIO1	
Reset Value	1	0	0**	1	0	0	0	0

Note: \*\* denotes EPROM programmable registers for default value.

### SYSTEM CONTROL REGISTER (SCR2) 8h'0E DEFINITIONS

Bit	Access	Name	Description
7	R/W	BBCS	Sets GPIO1 as control input for Back Up battery charger 0 = Back Up battery Charger GPIO Disabled 1 = Back Up battery Charger GPIO Pin Enabled
6	R/W	SEB2	PWR_EN soft Low voltage Supply Enabled OR'ed with PWR_EN Pin 0 = Low voltage Supply Output Enabled 1 = Low voltage Supply Output Disabled
5	R/W	BPTR	Bypass RTC_LDO Output Voltage to LDO1 Output Voltage Tracking 0 = RTC_LDO1 Tracking enabled 1 = RTC-LDO1 Tracking disabled
4	R/W	WUP3_ sense	Spare Wakeup control input 0 = Active High 1 = Active Low
3:2	R/W	GPIO2	Configure direction and output sense of GPIO2 Pin <b>Data Code</b> <b>GPIO2</b> 2h'00                    Hi-Z 2h'01                    Output Low 2h'02                    Input 2h'03                    Output high
1:0	R/W	GPIO1	Configure direction and output sense of GPIO1 Pin <b>Data Code</b> <b>GPIO1</b> 2h'00                    Hi-Z 2h'01                    Output Low 2h'02                    Input 2h'03                    Output high



## I<sup>2</sup>C Register Definitions (Continued)

### BUCKS OUTPUT VOLTAGE ENABLE REGISTER (BOVEN) 8h'10

Bit	7	6	5	4	3	2	1	0
Designation	Reserved	B2ENC**	Reserved	B3EN	Reserved	B2EN	Reserved	B1EN
Reset Value	0	1**	0	1	0	1	0	1

Note: \*\* denotes EPROM programmable registers for default value.

### BUCKS ENABLE REGISTER (BOVEN) 8h'10 DEFINITIONS

Bit	Access	Name	Description
7	...	...	Reserved
6	R/W	B2ENC	Connects Buck 2 enable to SYS_EN or PWR_EN Logic Control pin 0 = Buck 2 enable connected to PWR_EN 1 = Buck 2 enable connected to SYS_EN
5	...	...	Reserved
4	R/W	B3EN	VCC_Buck3 Supply Output Enabled 0 = VCC_Buck3 Supply Output Disabled 1 = VCC_Buck3 Supply Output Enabled
3	...	...	Reserved
2	R/W	B2EN	VCC_Buck2 Supply Output Enabled 0 = VCC_Buck2 Supply Output Disabled 1 = VCC_Buck2 Supply Output Enabled
1	...	...	Reserved
0	R/W	B1EN	VCC_Buck1 Supply Output Enabled 0 = VCC_Buck2 Supply Output Disabled 1 = VCC_Buck2 Supply Output Enabled

### BUCK STATUS REGISTER (BOVSR) 8h'11

Bit	7	6	5	4	3	2	1	0
Designation	BT_OK	Reserved	Reserved	B3_OK	Reserved	B2_OK		B1_OK
Reset Value	0	0	0	0	0	0	0	0

### BUCK STATUS REGISTER (BOVSR) 8h'11 DEFINITIONS

Bit	Access	Name	Description
7	R	BT_OK	Buck 1–3 Supply Output Voltage Status 0 = (Buck 1–3) output voltage <90% Default value 1 = (Buck 1–3) output voltage >90% Default value
6:5	...	...	Reserved
4	R	B3_OK	Buck 3 Supply Output Voltage Status 0 = (Buck 3) output voltage <90% Default value 1 = (Buck 3) output voltage >90% Default value
3	...	...	Reserved
2	R	B2_OK	Buck 2 Supply Output Voltage Status 0 = (Buck 2) output voltage <90% Default value 1 = (Buck 2) output voltage >90% Default value
1	...	...	Reserved
0	R	B1_OK	Buck 1 Supply Output Voltage Status 0 = (Buck 1) output voltage <90% Default value 1 = (Buck 1) output voltage >90% Default value



## I<sup>2</sup>C Register Definitions (Continued)

### LDO OUTPUT VOLTAGE ENABLE REGISTER (LDOEN) 8h'12

Bit	7	6	5	4	3	2	1	0
Designation	L5EC**	L4EC**	LDO5_EN	LDO4_EN	LDO3_EN	LDO2_EN	LDO1_EN	Reserved
Reset Value	0**	0**	1	1	1	1	1	0

Note: \*\* denotes EPROM programmable registers for default value.

### LDO OUTPUT VOLTAGE ENABLE REGISTER (LDOEN) 8h'12 DEFINITIONS

Bit	Access	Name	Description
7	R/W	L5EC	Connects LDO5 enable to SYS_EN or PWR_EN Logic Control pin 0 = LDO 5 enable connected to PWR_EN 1 = LDO 5 enable connected to SYS_EN
6	R/W	L4EC	Connects LDO4 enable to SYS_EN or PWR_EN Logic Control pin 0 = LDO 4 enable connected to PWR_EN 1 = LDO 4 enable connected to SYS_EN
5	R/W	LDO5_EN	LDO_5 Output Voltage Enable 0 = LDO5 Supply Output Disabled 1 = LDO5 Supply Output Enabled
4	R/W	LDO4_EN	LDO_4 Output Voltage Enable 0 = LDO4 Supply Output Disabled 1 = LDO4 Supply Output Enabled
3	R/W	LDO3_EN	LDO_3 Output Voltage Enable 0 = LDO3 Supply Output Disabled 1 = LDO3 Supply Output Enabled
2	R/W	LDO2_EN	LDO_2 Output Voltage Enable 0 = LDO2 Supply Output Disabled 1 = LDO2 Supply Output Enabled
1	R/W	LDO1_EN	LDO_1 Output Voltage Enable 0 = LDO1 Supply Output Disabled 1 = LDO1 Supply Output Enabled
0	...	...	Reserved

### LDO OUTPUT VOLTAGE STATUS REGISTER (LDOVS) 8h'13

Bit	7	6	5	4	3	2	1	0
Designation	LDOS_OK	N/A	LDO5_OK	LDO4_OK	LDO3_OK	LDO2_OK	LDO1_OK	N/A
Reset Value	0	0	0	0	0	0	0	0

### LDO OUTPUT VOLTAGE STATUS REGISTER (LDOVS) 8h'13 DEFINITIONS

Bit	Access	Name	Description
7	R	LDO_OK	LDO 1–5 Supply Output Voltage Status 0 = (LDO 1–5) output voltage <90% of selected value 1 = (LDO 1–5) output voltage >90% of selected value
6	...	...	Reserved
5	R	LDO5_OK	LDO_5 Output Voltage Status 0 = (VCC_LDO5) output voltage <90% of selected value 1 = (VCC_LDO5) output voltage >90% of selected value
4	R	LDO4_OK	LDO_4 Output Voltage Status 0 = (VCC_LDO4) output voltage <90% of selected value 1 = (VCC_LDO4) output voltage >90% of selected value
3	R	LDO3_OK	LDO_3 Output Voltage Status 0 = (VCC_LDO3) output voltage <90% of selected value 1 = (VCC_LDO3) output voltage >90% of selected value



## I<sup>2</sup>C Register Definitions (Continued)

Bit	Access	Name	Description
2	R	LDO2_OK	LDO_2 Output Voltage Status 0 = (VCC_LDO2) output voltage <90% of selected value 1 = (VCC_LDO2) output voltage >90% of selected value
1	R	LDO1_OK	LDO_1 Output Voltage Status 0 = (VCC_LDO1) output voltage <90% of selected value 1 = (VCC_LDO1) output voltage >90% of selected value
0	...	...	Reserved

### VOLTAGE CHANGE CONTROL REGISTER 1 (VCC1) 8h'20

Bit	7	6	5	4	3	2	1	0
Designation	B3VS	B3GO	B2VS	B2GO	Reserved		B2VS	B2GO
Reset Value	0	0	0	0	0	0	0	0

### VOLTAGE CHANGE CONTROL REGISTER 1 (VCC1) 8h'20 DEFINITIONS

Bit	Access	Name	Description
7	R/W	B3VS	Buck 3 Target Voltage Select 0 = Buck 3 Output Voltage to B1TV1 1 = Buck 3 Output Voltage to B1TV2
6	R/W	B3GO	Start Buck 3 Voltage Change 0 = Hold Buck 3 Output Voltage at current level 1 = Ramp Buck 3 Output Voltage as selected by B3VS
5	R/W	B2VS	Buck 2 Target Voltage Select 0 = Buck 2 Output Voltage to B2TV1 1 = Buck 2 Output Voltage to B2TV2
4	R/W	B2GO	Start Buck 2 Voltage Change 0 = Hold Buck 2 Output Voltage at current level 1 = Ramp Buck 2 Output Voltage as selected by B2VS
3:2	...	...	Reserved
1	R/W	B1VS	Buck 1 Target Voltage Select 0 = Buck 2 Output Voltage to B1TV1 1 = Buck 2 Output Voltage to B1TV2
0	R/W	B1GO	Start Buck 1 Voltage Change 0 = Hold Buck 3 Output Voltage at current level 1 = Ramp Buck 3 Output Voltage as selected by B1VS





## I<sup>2</sup>C Register Definitions (Continued)

### BUCK1 TARGET VOLTAGE 1 REGISTER (B1TV1) 8h'23

Bit	7	6	5	4	3	2	1	0
Designation	Reserved			Buck 1 Output Voltage (B1OV)**				
Reset Value	0	0	0**	0**	1**	1**	0**	1**

Note: \*\* denotes EPROM programmable registers for default value.

### BUCK1 TARGET VOLTAGE 1 REGISTER (B1TV1) 8h'23 DEFINITIONS

Bit	Access	Name	Description																																																				
7:5	...	...	Reserved																																																				
4:0	R/W	B1OV	Output Voltage																																																				
			<table border="1"> <thead> <tr> <th>Data Code</th> <th>(V)</th> <th>Data Code</th> <th>(V)</th> </tr> </thead> <tbody> <tr> <td>5h'01</td> <td>0.80</td> <td><b>5h'0D</b></td> <td><b>1.40</b></td> </tr> <tr> <td>5h'02</td> <td>0.85</td> <td>5h'0E</td> <td>1.45</td> </tr> <tr> <td>5h'03</td> <td>0.90</td> <td>5h'0F</td> <td>1.50</td> </tr> <tr> <td>5h'04</td> <td>0.95</td> <td>5h'11</td> <td>1.60</td> </tr> <tr> <td>5h'05</td> <td>1.00</td> <td>5h'12</td> <td>1.65</td> </tr> <tr> <td>5h'06</td> <td>1.05</td> <td>5h'13</td> <td>1.70</td> </tr> <tr> <td>5h'07</td> <td>1.10</td> <td>5h'14</td> <td>1.80</td> </tr> <tr> <td>5h'08</td> <td>1.15</td> <td>5h'15</td> <td>1.90</td> </tr> <tr> <td>5h'09</td> <td>1.20</td> <td>5h'16</td> <td>2.50</td> </tr> <tr> <td>5h'0A</td> <td>1.25</td> <td>5h'17</td> <td>2.80</td> </tr> <tr> <td>5h'0B</td> <td>1.30</td> <td>5h'18</td> <td>3.00</td> </tr> <tr> <td>5h'0C</td> <td>1.35</td> <td>5h'19</td> <td>3.30</td> </tr> </tbody> </table>	Data Code	(V)	Data Code	(V)	5h'01	0.80	<b>5h'0D</b>	<b>1.40</b>	5h'02	0.85	5h'0E	1.45	5h'03	0.90	5h'0F	1.50	5h'04	0.95	5h'11	1.60	5h'05	1.00	5h'12	1.65	5h'06	1.05	5h'13	1.70	5h'07	1.10	5h'14	1.80	5h'08	1.15	5h'15	1.90	5h'09	1.20	5h'16	2.50	5h'0A	1.25	5h'17	2.80	5h'0B	1.30	5h'18	3.00	5h'0C	1.35	5h'19	3.30
Data Code	(V)	Data Code	(V)																																																				
5h'01	0.80	<b>5h'0D</b>	<b>1.40</b>																																																				
5h'02	0.85	5h'0E	1.45																																																				
5h'03	0.90	5h'0F	1.50																																																				
5h'04	0.95	5h'11	1.60																																																				
5h'05	1.00	5h'12	1.65																																																				
5h'06	1.05	5h'13	1.70																																																				
5h'07	1.10	5h'14	1.80																																																				
5h'08	1.15	5h'15	1.90																																																				
5h'09	1.20	5h'16	2.50																																																				
5h'0A	1.25	5h'17	2.80																																																				
5h'0B	1.30	5h'18	3.00																																																				
5h'0C	1.35	5h'19	3.30																																																				

### BUCK1 TARGET VOLTAGE 2 REGISTER (B1TV2) 8h'24

Bit	7	6	5	4	3	2	1	0
Designation	Reserved			Buck 1 Output Voltage (B1OV)**				
Reset Value	0	0	0	0**	1**	1**	0**	1**

Note: \*\* denotes EPROM programmable registers for default value.

### BUCK1 TARGET VOLTAGE 2 REGISTER (B1TV2) 8h'24 DEFINITIONS

Bit	Access	Name	Description																																																				
7:5	...	...	Reserved																																																				
4:0	R/W	B1OV	Output Voltage																																																				
			<table border="1"> <thead> <tr> <th>Data Code</th> <th>(V)</th> <th>Data Code</th> <th>(V)</th> </tr> </thead> <tbody> <tr> <td>5h'01</td> <td>0.80</td> <td><b>5h'0D</b></td> <td><b>1.40</b></td> </tr> <tr> <td>5h'02</td> <td>0.85</td> <td>5h'0E</td> <td>1.45</td> </tr> <tr> <td>5h'03</td> <td>0.90</td> <td>5h'0F</td> <td>1.50</td> </tr> <tr> <td>5h'04</td> <td>0.95</td> <td>5h'11</td> <td>1.60</td> </tr> <tr> <td>5h'05</td> <td>1.00</td> <td>5h'12</td> <td>1.65</td> </tr> <tr> <td>5h'06</td> <td>1.05</td> <td>5h'13</td> <td>1.70</td> </tr> <tr> <td>5h'07</td> <td>1.10</td> <td>5h'14</td> <td>1.80</td> </tr> <tr> <td>5h'08</td> <td>1.15</td> <td>5h'15</td> <td>1.90</td> </tr> <tr> <td>5h'09</td> <td>1.20</td> <td>5h'16</td> <td>2.50</td> </tr> <tr> <td>5h'0A</td> <td>1.25</td> <td>5h'17</td> <td>2.80</td> </tr> <tr> <td>5h'0B</td> <td>1.30</td> <td>5h'18</td> <td>3.00</td> </tr> <tr> <td>5h'0C</td> <td>1.35</td> <td>5h'19</td> <td>3.30</td> </tr> </tbody> </table>	Data Code	(V)	Data Code	(V)	5h'01	0.80	<b>5h'0D</b>	<b>1.40</b>	5h'02	0.85	5h'0E	1.45	5h'03	0.90	5h'0F	1.50	5h'04	0.95	5h'11	1.60	5h'05	1.00	5h'12	1.65	5h'06	1.05	5h'13	1.70	5h'07	1.10	5h'14	1.80	5h'08	1.15	5h'15	1.90	5h'09	1.20	5h'16	2.50	5h'0A	1.25	5h'17	2.80	5h'0B	1.30	5h'18	3.00	5h'0C	1.35	5h'19	3.30
Data Code	(V)	Data Code	(V)																																																				
5h'01	0.80	<b>5h'0D</b>	<b>1.40</b>																																																				
5h'02	0.85	5h'0E	1.45																																																				
5h'03	0.90	5h'0F	1.50																																																				
5h'04	0.95	5h'11	1.60																																																				
5h'05	1.00	5h'12	1.65																																																				
5h'06	1.05	5h'13	1.70																																																				
5h'07	1.10	5h'14	1.80																																																				
5h'08	1.15	5h'15	1.90																																																				
5h'09	1.20	5h'16	2.50																																																				
5h'0A	1.25	5h'17	2.80																																																				
5h'0B	1.30	5h'18	3.00																																																				
5h'0C	1.35	5h'19	3.30																																																				



## I<sup>2</sup>C Register Definitions (Continued)

### BUCK 1 VOLTAGE RAMP CONTROL REGISTER (B1RC) 8h'25

Bit	7	6	5	4	3	2	1	0
Designation	Reserved				Ramp Rate			
Reset Value	0	0	0	0	1	0	1	0

### BUCK 1 VOLTAGE RAMP CONTROL REGISTER (B1RC) 8h'25 DEFINITIONS

Bit	Access	Name	Description																								
7:5	...	...	Reserved																								
4:0	R/W	B1RS	DVM Ramp Speed																								
			<table border="0"> <thead> <tr> <th>Data Code</th> <th>Ramp Rate (mV/μs)</th> </tr> </thead> <tbody> <tr> <td>4h'0</td> <td>Instant</td> </tr> <tr> <td>4h'1</td> <td>1</td> </tr> <tr> <td>4h'2</td> <td>2</td> </tr> <tr> <td>4h'3</td> <td>3</td> </tr> <tr> <td>4h'4</td> <td>4</td> </tr> <tr> <td>4h'5</td> <td>5</td> </tr> <tr> <td>4h'6</td> <td>6</td> </tr> <tr> <td>4h'7</td> <td>7</td> </tr> <tr> <td>4h'8</td> <td>8</td> </tr> <tr> <td>4h'9</td> <td>9</td> </tr> <tr> <td>4h'A</td> <td>10</td> </tr> </tbody> </table>	Data Code	Ramp Rate (mV/μs)	4h'0	Instant	4h'1	1	4h'2	2	4h'3	3	4h'4	4	4h'5	5	4h'6	6	4h'7	7	4h'8	8	4h'9	9	4h'A	10
Data Code	Ramp Rate (mV/μs)																										
4h'0	Instant																										
4h'1	1																										
4h'2	2																										
4h'3	3																										
4h'4	4																										
4h'5	5																										
4h'6	6																										
4h'7	7																										
4h'8	8																										
4h'9	9																										
4h'A	10																										

### BUCK 2 TARGET VOLTAGE 1 REGISTER (B2TV1) 8h'29

Bit	7	6	5	4	3	2	1	0
Designation	Reserved			Buck 2 Output Voltage (B2OV)**				
Reset Value	0	0	0	1**	1**	0**	0**	0**

Note: \*\* denotes EPROM programmable registers for default value.

### BUCK 2 TARGET VOLTAGE 1 REGISTER (B2TV1) 8h'29 DEFINITIONS

Bit	Access	Name	Description																																																				
7:5	...	...	Reserved																																																				
4:0	R/W	B2OV	Output Voltage																																																				
			<table border="0"> <thead> <tr> <th>Data Code</th> <th>(V)</th> <th>Data Code</th> <th>(V)</th> </tr> </thead> <tbody> <tr> <td>5h'01</td> <td>0.80</td> <td>5h'0D</td> <td>1.40</td> </tr> <tr> <td>5h'02</td> <td>0.85</td> <td>5h'0E</td> <td>1.45</td> </tr> <tr> <td>5h'03</td> <td>0.90</td> <td>5h'0F</td> <td>1.50</td> </tr> <tr> <td>5h'04</td> <td>0.95</td> <td>5h'11</td> <td>1.60</td> </tr> <tr> <td>5h'05</td> <td>1.00</td> <td>5h'12</td> <td>1.65</td> </tr> <tr> <td>5h'06</td> <td>1.05</td> <td>5h'13</td> <td>1.70</td> </tr> <tr> <td>5h'07</td> <td>1.10</td> <td>5h'14</td> <td>1.80</td> </tr> <tr> <td>5h'08</td> <td>1.15</td> <td>5h'15</td> <td>1.90</td> </tr> <tr> <td>5h'09</td> <td>1.20</td> <td>5h'16</td> <td>2.50</td> </tr> <tr> <td>5h'0A</td> <td>1.25</td> <td>5h'17</td> <td>2.80</td> </tr> <tr> <td>5h'0B</td> <td>1.30</td> <td><b>5h'18</b></td> <td><b>3.00</b></td> </tr> <tr> <td>5h'0C</td> <td>1.35</td> <td>5h'19</td> <td>3.30</td> </tr> </tbody> </table>	Data Code	(V)	Data Code	(V)	5h'01	0.80	5h'0D	1.40	5h'02	0.85	5h'0E	1.45	5h'03	0.90	5h'0F	1.50	5h'04	0.95	5h'11	1.60	5h'05	1.00	5h'12	1.65	5h'06	1.05	5h'13	1.70	5h'07	1.10	5h'14	1.80	5h'08	1.15	5h'15	1.90	5h'09	1.20	5h'16	2.50	5h'0A	1.25	5h'17	2.80	5h'0B	1.30	<b>5h'18</b>	<b>3.00</b>	5h'0C	1.35	5h'19	3.30
Data Code	(V)	Data Code	(V)																																																				
5h'01	0.80	5h'0D	1.40																																																				
5h'02	0.85	5h'0E	1.45																																																				
5h'03	0.90	5h'0F	1.50																																																				
5h'04	0.95	5h'11	1.60																																																				
5h'05	1.00	5h'12	1.65																																																				
5h'06	1.05	5h'13	1.70																																																				
5h'07	1.10	5h'14	1.80																																																				
5h'08	1.15	5h'15	1.90																																																				
5h'09	1.20	5h'16	2.50																																																				
5h'0A	1.25	5h'17	2.80																																																				
5h'0B	1.30	<b>5h'18</b>	<b>3.00</b>																																																				
5h'0C	1.35	5h'19	3.30																																																				



## I<sup>2</sup>C Register Definitions (Continued)

### BUCK 2 TARGET VOLTAGE 2 REGISTER (B2TV2) 8h'2A

Bit	7	6	5	4	3	2	1	0
Designation	Reserved			Buck 2 Output Voltage (B2OV)**				
Reset Value	0	0	0	1**	1**	0**	0**	0**

Note: \*\* denotes EPROM programmable registers for default value.

### BUCK 2 TARGET VOLTAGE 2 REGISTER (B2TV2) 8h'2A DEFINITIONS

Bit	Access	Name	Description																																																				
7:5	...	...	Reserved																																																				
4:0	R/W	B2OV	Output Voltage																																																				
			<table border="1"> <thead> <tr> <th>Data Code</th> <th>(V)</th> <th>Data Code</th> <th>(V)</th> </tr> </thead> <tbody> <tr><td>5h'01</td><td>0.80</td><td>5h'0D</td><td>1.40</td></tr> <tr><td>5h'02</td><td>0.85</td><td>5h'0E</td><td>1.45</td></tr> <tr><td>5h'03</td><td>0.90</td><td>5h'0F</td><td>1.50</td></tr> <tr><td>5h'04</td><td>0.95</td><td>5h'11</td><td>1.60</td></tr> <tr><td>5h'05</td><td>1.00</td><td>5h'12</td><td>1.65</td></tr> <tr><td>5h'06</td><td>1.05</td><td>5h'13</td><td>1.70</td></tr> <tr><td>5h'07</td><td>1.10</td><td>5h'14</td><td>1.80</td></tr> <tr><td>5h'08</td><td>1.15</td><td>5h'15</td><td>1.90</td></tr> <tr><td>5h'09</td><td>1.20</td><td>5h'16</td><td>2.50</td></tr> <tr><td>5h'0A</td><td>1.25</td><td>5h'17</td><td>2.80</td></tr> <tr><td>5h'0B</td><td>1.30</td><td><b>5h'18</b></td><td><b>3.00</b></td></tr> <tr><td>5h'0C</td><td>1.35</td><td>5h'19</td><td>3.30</td></tr> </tbody> </table>	Data Code	(V)	Data Code	(V)	5h'01	0.80	5h'0D	1.40	5h'02	0.85	5h'0E	1.45	5h'03	0.90	5h'0F	1.50	5h'04	0.95	5h'11	1.60	5h'05	1.00	5h'12	1.65	5h'06	1.05	5h'13	1.70	5h'07	1.10	5h'14	1.80	5h'08	1.15	5h'15	1.90	5h'09	1.20	5h'16	2.50	5h'0A	1.25	5h'17	2.80	5h'0B	1.30	<b>5h'18</b>	<b>3.00</b>	5h'0C	1.35	5h'19	3.30
Data Code	(V)	Data Code	(V)																																																				
5h'01	0.80	5h'0D	1.40																																																				
5h'02	0.85	5h'0E	1.45																																																				
5h'03	0.90	5h'0F	1.50																																																				
5h'04	0.95	5h'11	1.60																																																				
5h'05	1.00	5h'12	1.65																																																				
5h'06	1.05	5h'13	1.70																																																				
5h'07	1.10	5h'14	1.80																																																				
5h'08	1.15	5h'15	1.90																																																				
5h'09	1.20	5h'16	2.50																																																				
5h'0A	1.25	5h'17	2.80																																																				
5h'0B	1.30	<b>5h'18</b>	<b>3.00</b>																																																				
5h'0C	1.35	5h'19	3.30																																																				

### BUCK 2 VOLTAGE RAMP CONTROL REGISTER (B2RC) 8h'2B

Bit	7	6	5	4	3	2	1	0
Designation	Reserved				Ramp Rate			
Reset Value	0	0	0	0	1	0	1	0

### BUCK 2 VOLTAGE RAMP CONTROL REGISTER (B2RC) 8h'2B DEFINITIONS

Bit	Access	Name	Description																								
7:5	...	...	Reserved																								
4:0	R/W	B2RS	DVM Ramp Speed																								
			<table border="1"> <thead> <tr> <th>Data Code</th> <th>Ramp Rate (mV/μs)</th> </tr> </thead> <tbody> <tr><td>4h'0</td><td>Instant</td></tr> <tr><td>4h'1</td><td>1</td></tr> <tr><td>4h'2</td><td>2</td></tr> <tr><td>4h'3</td><td>3</td></tr> <tr><td>4h'4</td><td>4</td></tr> <tr><td>4h'5</td><td>5</td></tr> <tr><td>4h'6</td><td>6</td></tr> <tr><td>4h'7</td><td>7</td></tr> <tr><td>4h'8</td><td>8</td></tr> <tr><td>4h'9</td><td>9</td></tr> <tr><td><b>4h'A</b></td><td><b>10</b></td></tr> </tbody> </table>	Data Code	Ramp Rate (mV/μs)	4h'0	Instant	4h'1	1	4h'2	2	4h'3	3	4h'4	4	4h'5	5	4h'6	6	4h'7	7	4h'8	8	4h'9	9	<b>4h'A</b>	<b>10</b>
Data Code	Ramp Rate (mV/μs)																										
4h'0	Instant																										
4h'1	1																										
4h'2	2																										
4h'3	3																										
4h'4	4																										
4h'5	5																										
4h'6	6																										
4h'7	7																										
4h'8	8																										
4h'9	9																										
<b>4h'A</b>	<b>10</b>																										



## I<sup>2</sup>C Register Definitions (Continued)

### BUCK 3 TARGET VOLTAGE 1 REGISTER (B3TV1) 8h'32

Bit	7	6	5	4	3	2	1	0
Designation	Reserved			Buck 3 Output Voltage (B3OV)**				
Reset Value	0	0	0	1**	0**	1**	0**	0**

Note: \*\* denotes EPROM programmable registers for default value.

### BUCK 3 TARGET VOLTAGE 1 REGISTER (B3TV1) 8h'32 DEFINITIONS

Bit	Access	Name	Description			
7:5	...	...	Reserved			
4:0	R/W	B3OV	Output Voltage			
			<b>Data Code</b>	<b>(V)</b>	<b>Data Code</b>	<b>(V)</b>
			5h'01	0.80	5h'0D	1.40
			5h'02	0.85	5h'0E	1.45
			5h'03	0.90	5h'0F	1.50
			5h'04	0.95	5h'11	1.60
			5h'05	1.00	5h'12	1.65
			5h'06	1.05	5h'13	1.70
			5h'07	1.10	<b>5h'14</b>	<b>1.80</b>
			5h'08	1.15	5h'15	1.90
			5h'09	1.20	5h'16	2.50
			5h'0A	1.25	5h'17	2.80
			5h'0B	1.30	5h'18	3.00
			5h'0C	1.35	5h'19	3.30

### BUCK 3 TARGET VOLTAGE 2 REGISTER (B3TV2) 8h'33

Bit	7	6	5	4	3	2	1	0
Designation	Reserved			Buck 2 Output Voltage (B2OV)**				
Reset Value	0	0	0	1**	0**	1**	0**	0**

Note: \*\* denotes EPROM programmable registers for default value.

### BUCK 3 TARGET VOLTAGE 2 REGISTER (B3TV2) 8h'33 DEFINITIONS

Bit	Access	Name	Description			
7:5	...	...	Reserved			
4:0	R/W	B2OV	Output Voltage			
			<b>Data Code</b>	<b>(V)</b>	<b>Data Code</b>	<b>(V)</b>
			5h'01	0.80	5h'0D	1.40
			5h'02	0.85	5h'0E	1.45
			5h'03	0.90	5h'0F	1.50
			5h'04	0.95	5h'11	1.60
			5h'05	1.00	5h'12	1.65
			5h'06	1.05	5h'13	1.70
			5h'07	1.10	5h'14	1.80
			5h'08	1.15	5h'15	1.90
			5h'09	1.20	5h'16	2.50
			5h'0A	1.25	5h'17	2.80
			5h'0B	1.30	5h'18	3.00
			5h'0C	1.35	5h'19	3.30



## I<sup>2</sup>C Register Definitions (Continued)

### BUCK 3 VOLTAGE RAMP CONTROL REGISTER (B3RC) 8h'34

Bit	7	6	5	4	3	2	1	0
Designation	Reserved				Ramp Rate			
Reset Value	0	0	0	0	1	0	1	0

### BUCK 2 VOLTAGE RAMP CONTROL REGISTER (B2RC) 8h'34 DEFINITIONS

Bit	Access	Name	Description																								
7:5	...	...	Reserved																								
4:0	R/W	B2RS	DVM Ramp Speed																								
			<table border="1"> <thead> <tr> <th>Data Code</th> <th>Ramp Rate (mV/μs)</th> </tr> </thead> <tbody> <tr> <td>4h'0</td> <td>Instant</td> </tr> <tr> <td>4h'1</td> <td>1</td> </tr> <tr> <td>4h'2</td> <td>2</td> </tr> <tr> <td>4h'3</td> <td>3</td> </tr> <tr> <td>4h'4</td> <td>4</td> </tr> <tr> <td>4h'5</td> <td>5</td> </tr> <tr> <td>4h'6</td> <td>6</td> </tr> <tr> <td>4h'7</td> <td>7</td> </tr> <tr> <td>4h'8</td> <td>8</td> </tr> <tr> <td>4h'9</td> <td>9</td> </tr> <tr> <td>4h'A</td> <td>10</td> </tr> </tbody> </table>	Data Code	Ramp Rate (mV/μs)	4h'0	Instant	4h'1	1	4h'2	2	4h'3	3	4h'4	4	4h'5	5	4h'6	6	4h'7	7	4h'8	8	4h'9	9	4h'A	10
Data Code	Ramp Rate (mV/μs)																										
4h'0	Instant																										
4h'1	1																										
4h'2	2																										
4h'3	3																										
4h'4	4																										
4h'5	5																										
4h'6	6																										
4h'7	7																										
4h'8	8																										
4h'9	9																										
4h'A	10																										

### BUCK FUNCTION REGISTER (BFR) 8h'38

Bit	7	6	5	4	3	2	1	0
Designation	Reserved				SHBU	BK_SLOMOD	BK_SSEN	
Reset Value	0	0	0	0	0	0	1	0

### BUCK FUNCTION REGISTER (BFR) 8h'38 DEFINITIONS

Bit	Access	Name	Description
7:3	...	...	Reserved
		SHBU	Shut down Back up battery to prevent battery drain during shipping 0 = Back up Battery Enabled 1 = Back up Battery Disabled
1	R	BK_SLOMOD	Buck Spread Spectrum Modulation Buck 1–3 0 = 10 kHz triangular wave spread spectrum modulation 1 = 2 kHz triangular wave spread spectrum modulation
0	R	BK_SSEN	Spread spectrum function Buck 1–3 0 = SS Output Disabled 1 = SS Output Enabled



## I<sup>2</sup>C Register Definitions (Continued)

### LDO2-LDO1 VOLTAGE CONTROL REGISTER (L21VCR) 8h'39

Bit	7	6	5	4	3	2	1	0
Designation	LDO 2 Output Voltage (L2OV)**				LDO 1 Output Voltage (L1OV)**			
Reset Value	1**	1**	0**	0**	1**	1**	0**	0**

Note: \*\* denotes EPROM programmable registers for default value.

### LDO2-LDO1 VOLTAGE CONTROL REGISTER (L21VCR) 8h'39 DEFINITIONS

Bit	Access	Name	Description	
7:4	R/W	L2OV	<b>Data Code</b>	<b>Output Voltage</b>
			4h'0	1.8
			4h'1	1.9
			4h'2	2.0
			4h'3	2.1
			4h'4	2.2
			4h'5	2.3
			4h'6	2.4
			4h'7	2.5
			4h'8	2.6
			4h'9	2.7
			4h'A	2.8
			4h'B	2.9
			<b>4h'C</b>	<b>3.0</b>
			4h'D	3.1
4h'E	3.2			
4h'F	3.3			
3:0	R/W	L1OV	4h'0	1.8
			4h'1	1.9
			4h'2	2.0
			4h'3	2.1
			4h'4	2.2
			4h'5	2.3
			4h'6	2.4
			4h'7	2.5
			4h'8	2.6
			4h'9	2.7
			4h'A	2.8
			4h'B	2.9
			<b>4h'C</b>	<b>3.0</b>
			4h'D	3.1
			4h'E	3.2
4h'F	3.3			



## I<sup>2</sup>C Register Definitions (Continued)

### LDO4–LDO3 VOLTAGE CONTROL REGISTER (L21VCR) 8h'3A

Bit	7	6	5	4	3	2	1	0
Designation	LDO 4 Output Voltage (L4OV)**				LDO 3 Output Voltage (L3OV)**			
Reset Value	0**	1**	1**	0**	1**	1**	0**	0**

Note: \*\* denotes EPROM programmable registers for default value.

### LDO4–LDO3 VOLTAGE CONTROL REGISTER (L21VCR) 8h'3A DEFINITIONS

Bit	Access	Name	Description	
7:4	R/W	L4OV	<b>Data Code</b>	<b>Output Voltage</b>
			4h'0	1.00
			4h'1	1.05
			4h'2	1.10
			4h'3	1.15
			4h'4	1.20
			4h'5	1.25
			<b>4h'6</b>	<b>1.30</b>
			4h'7	1.35
			4h'8	1.40
			4h'9	1.50
			4h'A	1.80
			4h'B	1.90
			4h'C	2.50
			4h'D	2.80
4h'E	3.00			
4h'F	<b>3.30</b>			
3:0	R/W	L3OV	4h'0	1.8
			4h'1	1.9
			4h'2	2.0
			4h'3	2.1
			4h'4	2.2
			4h'5	2.3
			4h'6	2.4
			4h'7	2.5
			4h'8	2.6
			4h'9	2.7
			4h'A	2.8
			4h'B	2.9
			<b>4h'C</b>	<b>3.0</b>
			4h'D	3.1
			4h'E	3.2
4h'F	3.3			



## I<sup>2</sup>C Register Definitions (Continued)

### VCC\_LDO5 VOLTAGE CONTROL REGISTER (L5VCR) 8h'3B

Bit	7	6	5	4	3	2	1	0
Designation	Reserved				LDO 5 Output Voltage (L5OV)**			
Reset Value	0	0	0	0	0**	0**	1**	0**

Note: \*\* denotes EPROM programmable registers for default value.

### VCC\_LDO5 VOLTAGE CONTROL REGISTER (L5VCR) 8h'3B DEFINITIONS

Bit	Access	Name	Description	
7:5	...	...	Reserved	
4:0	R/W	B1OV	<b>Data Code</b>	<b>Output Voltage</b>
			4h'0	1.00
			4h'1	1.05
			<b>4h'2</b>	<b>1.10</b>
			4h'3	1.15
			4h'4	1.20
			4h'5	1.25
			4h'6	1.30
			4h'7	1.35
			4h'8	1.40
			4h'9	1.50
			4h'A	1.80
			4h'B	1.90
			4h'C	2.50
			4h'D	2.80
			4h'E	3.00
4h'F	3.30			

Serial interface register selection codes (Bold face voltages are default values).

#### Register Programming Examples

Example 1. Setting register 8h'12 value to 8h'3E' will enable LDOs 1–5.

Example 2. Setting register 8h'39 to 8h'CC' will set LDOs 1 and 2 to 3.0V. These voltages will appear at the LDO outputs if the corresponding LDO has been enabled. Programming a voltage value to a LDO, which is off, will affect the LDO output voltage after the LDO is enabled. Enabling and programming the output voltage are separate operations.





## I<sup>2</sup>C Register Definitions (Continued)

### I<sup>2</sup>C DVM TIMING FOR VCC APPS (Buck 1)

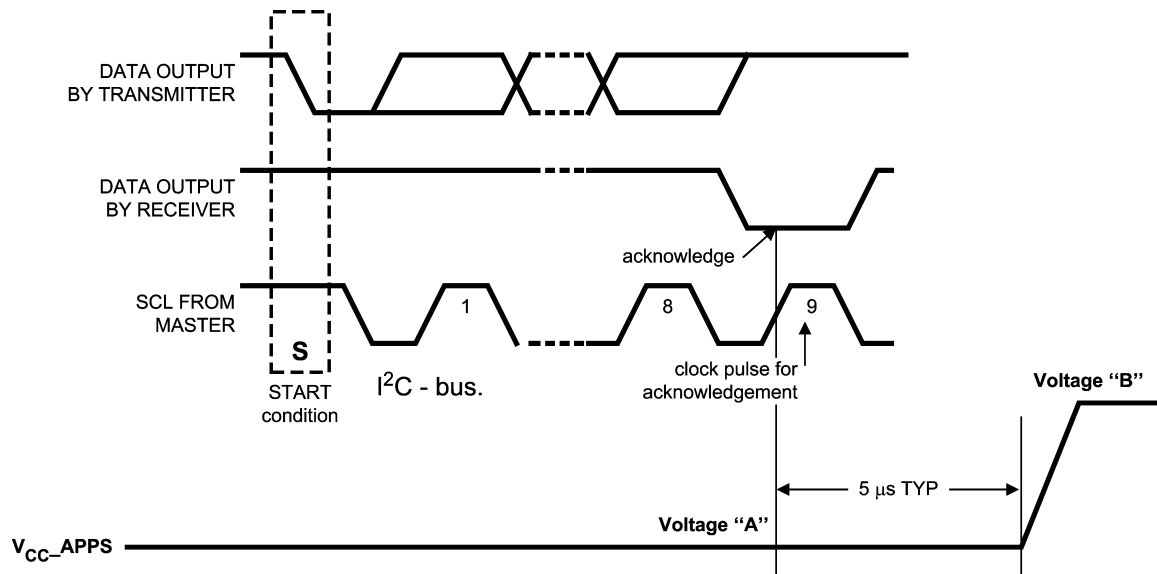

## LP3971 Controls

### DIGITAL INTERFACE CONTROL SIGNALS

Signal	Definition	Active State	Signal Direction
SYS_EN	High Voltage Power Enable	High	Input
PWR_EN	Low Voltage Power Enable	High	Input
SCL	Serial Bus Clock Line	Clock	Input
SDA	Serial Bus Data Line		Bidirectional
nRSTI	Forces an Unconditional Hardware Reset	Low	Input
nRSTO	Forces an Unconditional Hardware Reset	Low	Output
nBATT_FLT	Main Battery Removed or Discharged Indicator	Low	Output
PWR_ON	Wakeup Input to CPU	High	Input
nTEST_JIG	Wakeup Input to CPU	Low	Input
SPARE	Wakeup Input to CPU	High/Low*	Input
EXT_WAKEUP	Wake-Up Output for Application Processor	High	Output
GPIO1/nCHG_EN	General Purpose I/O/External Back-Up Battery Charger	-/Low	Bidirectional/Input
GPIO2	General Purpose I/O	-	Bidirectional

### POWER DOMAIN ENABLES

PMU Output	HW Enable	SW Enable
LDO_RTC	-	-
LDO1	SYS_EN	LDO1_EN
LDO2	SYS_EN	LDO2_EN
LDO3	SYS_EN	LDO3_EN
LDO4	PWR_EN/SYS_EN	LDO4_EN
LDO5	PWR_EN/SYS_EN	LDO5_EN
BUCK1	PWR_EN	B1_EN
BUCK2	SYS_EN/PWR_EN	B2_EN
BUCK3	SYS_EN	B3_EN

### LDO\_RTC TRACKING (nIO\_TRACK)

LP3971 has a tracking function (nIO\_TRACK). When enabled, LDO\_RTC voltage will track LDO1 voltage within 200 mV down to 2.8V when LDO1 is enabled. This function can be switched on/off by BPTR (8h'0E) register bit.

### LDO4, LDO5 AND BUCK 2 ENABLE SELECTION (LDO4\_ESEL, LDO5\_ESEL AND BUCK2\_ESEL)

LDO4, 5 and BUCK2 power domain enable is possible to change between SYS\_EN and PWR\_EN by register bits.

### WAKE-UP FUNCTIONALITY (PWR\_ON, nTEST\_JIG, SPARE AND EXT\_WAKEUP)

Three input pins can be used to assert wakeup output for 10 ms for application processor notification to wakeup. SPARE input can be programmed through I<sup>2</sup>C compatible interface



## LP3971 Controls (Continued)

to be active low or high (SPARE bit, Default is active low '1'). A reason for wakeup event can be read through I<sup>2</sup>C compatible interface also. Additionally wakeup inputs have 30 ms

de-bounce filtering. Furthermore PWR\_ON have distinguishing between short and long (~1s) pulses (push button input). LP3971 also has an internal Thermal Shutdown early warning that generates a wakeup to the system also. This is generated usually at 125°C.

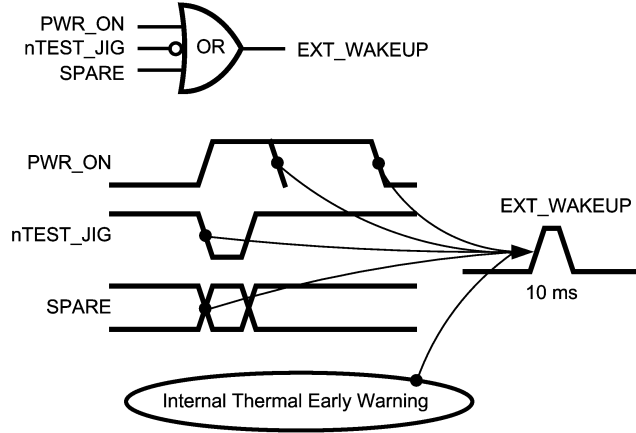

20180719

WAKEUP Register Bits	Reason for WAKEUP
WUP0	SPARE
WUP1	TEST_JIG
WUP2	PWR_ON Short Pulse
WUP3	PWR_ON Long Pulse
TSD_EW	TSD Early Warning

### INTERNAL THERMAL SHUTDOWN PROCEDURE

Thermal shutdown is build to generate early warning (typ. 125°C) which triggers the EXT\_WAKEUP for the processor acknowledge. When a thermal shutdown triggers (typ. 160°C) the PMU will reset the system until the device cools down.

### BATTERY SWITCH AND BACK UP BATTERY CHARGER

When Back-Up battery is connected but main battery removed or voltage too low, LP3971 uses Back-Up Battery for generating LDO\_RTC voltage. When Main Battery is available the battery switch changes main battery for LDO\_RTC voltage. When Main battery voltage is too low or removed nBATT\_FLT is asserted to system acknowledge. If no back up battery exists, the battery switch to back up can be switched off by nBU\_BAT\_EN bit. User can set the battery fault determination voltage and battery charger termination voltage via I<sup>2</sup>C compatible interface. Enabling of back up battery charger can be done via serial interface (nBAT\_CHG\_EN) or external charger enable pin (nCHG\_EN). Pin 29 is set as external charger enable input by default.



## LP3971 Controls (Continued)

### GENERAL PURPOSE I/O FUNCTIONALITY (GPIO1 AND GPIO2)

LP3971 has 2 general purpose I/Os for system control. I<sup>2</sup>C compatible interface will be used for setting any of the pins to

input, output or hi-Z mode. Inputs value can be read via serial interface (GP1,2 bits). The pin 29 functionality needs to be set to GPIO by serial interface register bit nEXTCHGEN.

### LP3971 GPIO Control Table

Controls				Port Function	Reg.	batmonchg
GPIO1<1>	GPIO1<0>	nextchgen_sel	bucen	GPIO1	gpin 1	Function
X	X	1	0	Input = 0	0	Enabled
X	X	1	o	Input = 1	0	Not Enabled
1	0	1	X	X	0	
X	X	X	1	X		Enabled
0	0	0	X	HiZ	0	
1	0	0	X	Input (dig)->	Input	
0	1	0	X	Output = 0	0	
1	1	0	X	Output= 1	0	

GPIO2<1>	GPIO2<0>	Factory fm disabled	GPIO_tstiob	GPIO2	gpin2
0	0		1	HiZ	0
1	0		1	Input (dig)->	Input
0	1		1	Output = 0	0
1	1		1	Output = 1	0

The LP3971 Back Up Charger can be enabled/disabled by two separate mechanisms. They are; 1) A dedicated control register bit named BUCEN (Register 0B Bit 2) and 2) GPIO1 input Pin 29, when configured for charger control.

Description of this operation is as follows:

- In the default state, the BUCEN bit is not asserted, and GPIO1 is configured as charger control. High level applied to GPIO1 will disable the back up charger, Low level applied to GPIO1 will enable the back up charger. There is an internal pull up that will disable the back up charger if GPIO1 is "open".
- If BUCEN bit is asserted with GPIO1 configured for charger control, the back up charger will always be enabled, and GPIO1 input will have no effect.
- Configuration of GPIO1 charger function is via control register bit named BBCS (Register 0E Bit 7). When this

bit is asserted (Default state), GPIO1 is charger control. When this bit is de-asserted, charger enable is determined only by the state of control register bit BUCEN.

- One additional feature of the charger enable is when the main battery voltage Vin (Pin 6) is less than the back up battery voltage Vin BUBATT (Pin 15), The charger will automatically disable regardless of the input received from BUCEN or GPIO1.

#### REGULATED VOLTAGES OK

All the power domains have own register bit (x\_OK) that processor can read via serial interface to be sure that enabled powers are OK (regulating). Note that these read only bits are only valid when regulators are settled (avoid reading these bits during voltage change or power up).



# Application Note

## TYPICAL CONNECTION DIAGRAMS

LP3971 is flexible for different system configurations. Different power domains can be selected based on current and voltage needs. Additionally Buck2 LDO4 and IDO5 default

enables can be changed for further flexibility. Please note that LDO1 is recommended to be used for I/Os if RTC voltage need to track I/O voltage. Also LDO4 and LDO5 has an own  $V_{IN}$  pin which can be driven from a buck regulator for higher system efficiency.

Typical Application Diagram with Advanced Applications Processor Version "A"

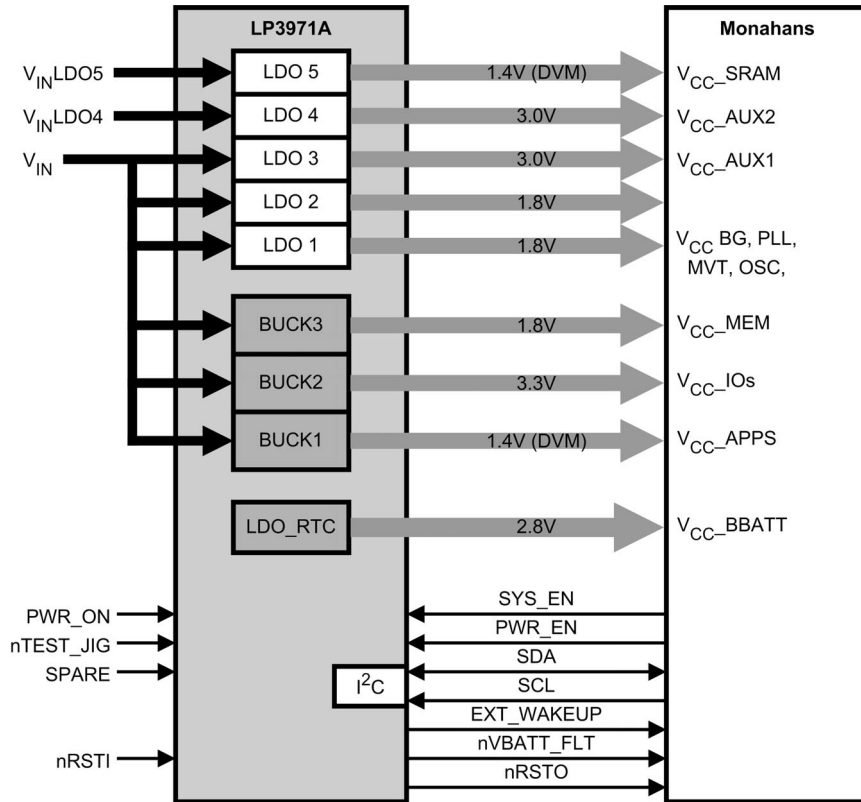

20180720



# Application Note (Continued)

Typical Application Diagram with PXA27x Advanced Applications Processor Version "B"

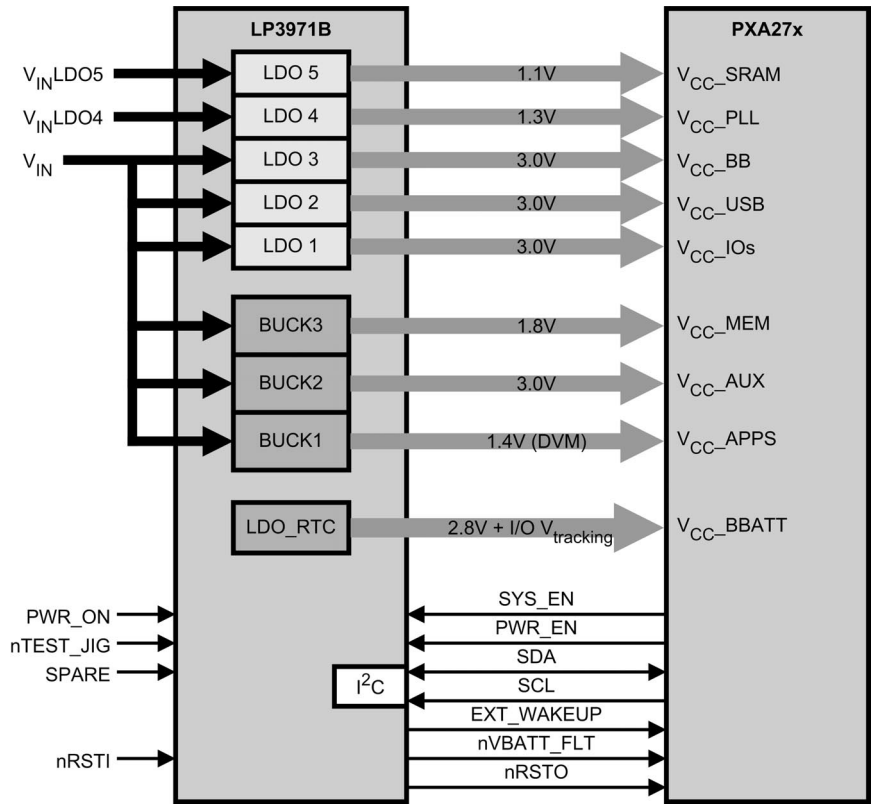

20180721

## LP3971 & PXA27x START-UP

### Initial Cold Start Power On Sequence

1. The Back up battery is connected to the PMU, power is applied to the back-up battery pin, the RTC\_LDO turns on and supplies a stable output voltage to the VCC\_BATT pin of the Applications processor (initiating the power-on reset event) with nRSTO asserted from the LP3971 to the processor.
2. The Applications processor waits for the de-assertion of nBATT\_FLT to indicate system power (V<sub>IN</sub>) is available.
3. IF system power (V<sub>bat</sub>) is available, the LP3971 de-asserts nBATT\_FLT.
4. nRSTO de-asserts after a minimum of 50 mS.
5. The Applications processor asserts SYS\_EN, the LP3971 enables the system high-voltage power supplies. The Applications processor starts its countdown timer set to 125 mS.
6. The LP3971 enables the high-voltage power supplies. -LDO1 power for VCC\_MVT, BG, OSC13M and PLL enabled first, followed by others if delay is on.
7. Countdown timer expires; the Applications processor asserts PWR\_EN (ext. pin or I<sup>2</sup>C) to enable the low-voltage power supplies. The processor starts the countdown timer set to 125 mS period.
8. The Applications processor asserts PWR\_EN (ext. pin or I<sup>2</sup>C), the LP3971 enables the low-voltage regulators.
9. Countdown timer expires; If enabled power domains are OK (I<sup>2</sup>C read) the power up sequence continues by enabling the processors 13 MHz oscillator and PLL's.
10. The Applications processor begins the execution of code.



## Application Note (Continued)

Code Start Power on Timing

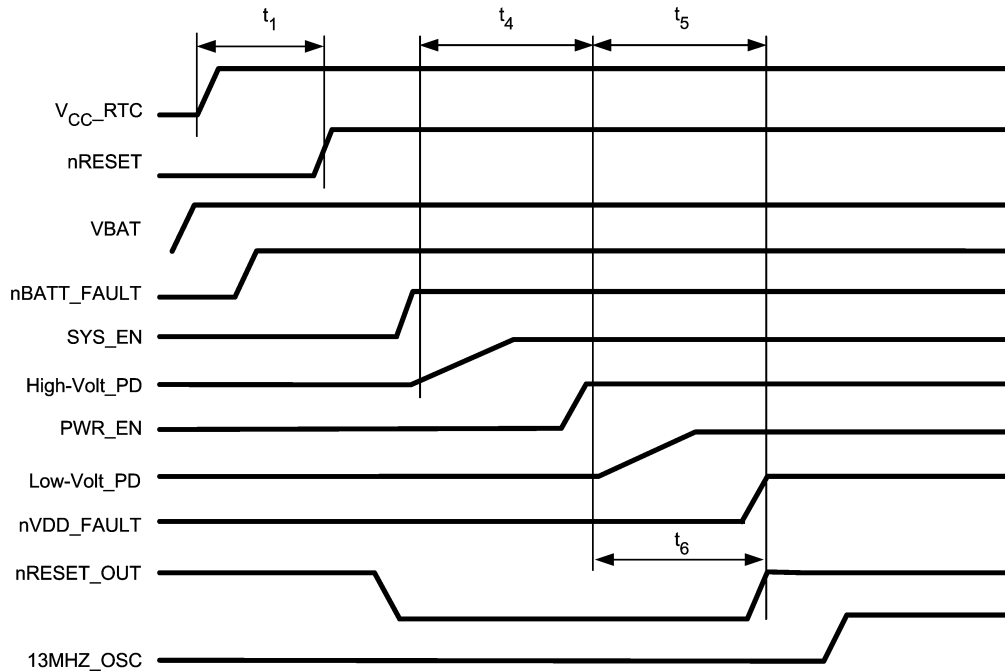

20180722

### POWER-ON TIMING

Symbol	Description	Min	Typ	Max	Units
t1	Delay from VCC_RTC assertion to nRSTO de-assertion	50			mS
t3	Delay from nRST de-assertion to SYS_EN assertion		10		mS
t4	Delay from SYS_EN assertion to PWR_EN assertion		125		mS
t5	Delay from PWR_EN assertion to nRSTO de-assertion		125		mS

### LP3971 & PXA27x RESET SEQUENCE

#### Hardware Reset Sequence

Hardware reset initiates when the nRSTI signal is asserted (low). Upon assertion of nRST the processor enters hardware reset state. The LP3971 holds the nRST low long enough (50ms typ.) to allow the processor time to initiate the reset state.

#### Reset Sequence

1. nRSTI is asserted
2. If  $V_{BATT}$  is above the set point the PMIC de-asserts nBATT\_FLT to indicate system power ( $V_{IN}$ ) is available.
3. nRSTO is asserted and will de-asserts after a minimum of 50 mS.
4. The Applications processor asserts SYS\_EN, the LP3971 enables the system high-voltage power sup-

plies. The Applications processor starts its countdown timer set to 125 mS.

5. The LP3971 enables the high-voltage power supplies.
6. Countdown timer expires; the Applications processor asserts PWR\_EN to enable the low-voltage power supplies. The processor starts the countdown timer set to 125 mS period.
7. The Applications processor asserts PWR\_EN, the LP3971 enables the low-voltage regulators.
8. Countdown timer expires; If enabled power domains are OK (I<sup>2</sup>C read) the power up sequence continues by enabling the processors 13 MHz oscillator and PLL's.
9. The Applications processor begins the execution of code.



## Application Hints

### LDO CONSIDERATIONS

#### External Capacitors

The LP3971's regulators require external capacitors for regulator stability. These are specifically designed for portable applications requiring minimum board space and smallest components. These capacitors must be correctly selected for good performance.

#### Input Capacitor

An input capacitor is required for stability. It is recommended that a 1.0  $\mu\text{F}$  capacitor be connected between the LDO input pin and ground (this capacitance value may be increased without limit).

This capacitor must be located a distance of not more than 1 cm from the input pin and returned to a clean analogue ground. Any good quality ceramic, tantalum, or film capacitor may be used at the input.

**Important:** Tantalum capacitors can suffer catastrophic failures due to surge current when connected to a low impedance source of power (like a battery or a very large capacitor). If a tantalum capacitor is used at the input, it must be guaranteed by the manufacturer to have a surge current rating sufficient for the application.

There are no requirements for the ESR (Equivalent Series Resistance) on the input capacitor, but tolerance and temperature coefficient must be considered when selecting the capacitor to ensure the capacitance will remain approximately 1.0  $\mu\text{F}$  over the entire operating temperature range.

#### Output Capacitor

The LDO's are designed specifically to work with very small ceramic output capacitors. A 1.0  $\mu\text{F}$  ceramic capacitor (temperature types Z5U, Y5V or X7R) with ESR between 5 m $\Omega$  to 500 m $\Omega$ , are suitable in the application circuit.

For this device the output capacitor should be connected between the  $V_{\text{OUT}}$  pin and ground.

It is also possible to use tantalum or film capacitors at the device output,  $C_{\text{OUT}}$  (or  $V_{\text{OUT}}$ ), but these are not as attractive for reasons of size and cost (see the section Capacitor Characteristics).

The output capacitor must meet the requirement for the minimum value of capacitance and also have an ESR value that is within the range 5 m $\Omega$  to 500 m $\Omega$  for stability.

#### No-Load Stability

The LDO's will remain stable and in regulation with no external load. This is an important consideration in some circuits, for example CMOS RAM keep-alive applications.

#### Capacitor Characteristics

The LDO's are designed to work with ceramic capacitors on the output to take advantage of the benefits they offer. For capacitance values in the range of 0.47  $\mu\text{F}$  to 4.7  $\mu\text{F}$ , ceramic capacitors are the smallest, least expensive and have the lowest ESR values, thus making them best for eliminating high frequency noise. The ESR of a typical 1.0  $\mu\text{F}$  ceramic capacitor is in the range of 20 m $\Omega$  to 40 m $\Omega$ , which easily meets the ESR requirement for stability for the LDO's.

For both input and output capacitors, careful interpretation of the capacitor specification is required to ensure correct device operation. The capacitor value can change greatly, depending on the operating conditions and capacitor type.

In particular, the output capacitor selection should take account of all the capacitor parameters, to ensure that the specification is met within the application. The capacitance can vary with DC bias conditions as well as temperature and frequency of operation. Capacitor values will also show some decrease over time due to aging. The capacitor parameters are also dependant on the particular case size, with smaller sizes giving poorer performance figures in general. As an example, *Figure 6* shows a typical graph comparing different capacitor case sizes in a Capacitance vs. DC Bias plot. As shown in the graph, increasing the DC Bias condition can result in the capacitance value falling below the minimum value given in the recommended capacitor specifications table. Note that the graph shows the capacitance out of spec for the 0402 case size capacitor at higher bias voltages. It is therefore recommended that the capacitor manufacturers' specifications for the nominal value capacitor are consulted for all conditions, as some capacitor sizes (e.g. 0402) may not be suitable in the actual application.

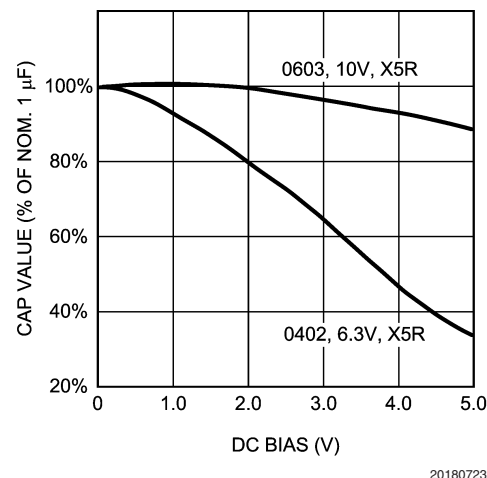

**FIGURE 6. Graph Showing a Typical Variation in Capacitance vs. DC Bias**

The ceramic capacitor's capacitance can vary with temperature. The capacitor type X7R, which operates over a temperature range of  $-55^{\circ}\text{C}$  to  $+125^{\circ}\text{C}$ , will only vary the capacitance to within  $\pm 15\%$ . The capacitor type X5R has a similar tolerance over a reduced temperature range of  $-55^{\circ}\text{C}$  to  $+85^{\circ}\text{C}$ . Many large value ceramic capacitors, larger than 1  $\mu\text{F}$  are manufactured with Z5U or Y5V temperature characteristics. Their capacitance can drop by more than 50% as the temperature varies from  $25^{\circ}\text{C}$  to  $85^{\circ}\text{C}$ . Therefore X7R is recommended over Z5U and Y5V in applications where the ambient temperature will change significantly above or below  $25^{\circ}\text{C}$ .

Tantalum capacitors are less desirable than ceramic for use as output capacitors because they are more expensive when comparing equivalent capacitance and voltage ratings in the 0.47  $\mu\text{F}$  to 4.7  $\mu\text{F}$  range.

Another important consideration is that tantalum capacitors have higher ESR values than equivalent size ceramics. This means that while it may be possible to find a tantalum capacitor with an ESR value within the stable range, it would





## Application Hints (Continued)

have to be larger in capacitance (which means bigger and more costly) than a ceramic capacitor with the same ESR value. It should also be noted that the ESR of a typical tantalum will increase about 2:1 as the temperature goes from 25°C down to -40°C, so some guard band must be allowed.

### BUCK CONSIDERATIONS

#### Inductor Selection

There are two main considerations when choosing an inductor; the inductor should not saturate, and the inductor current ripple is small enough to achieve the desired output voltage ripple. Different saturation current rating specs are followed by different manufacturers so attention must be given to details. Saturation current ratings are typically specified at 25°C so ratings at max ambient temperature of application should be requested from manufacturer.

There are two methods to choose the inductor saturation current rating.

#### Method 1:

The saturation current is greater than the sum of the maximum load current and the worst case average to peak inductor current. This can be written as

$$I_{SAT} > I_{OUTMAX} + I_{RIPPLE}$$

$$\text{where } I_{RIPPLE} = \left( \frac{V_{IN} - V_{OUT}}{2 * L} \right) * \left( \frac{V_{OUT}}{V_{IN}} \right) * \left( \frac{1}{f} \right)$$

- $I_{RIPPLE}$ : Average to peak inductor current
- $I_{OUTMAX}$ : Maximum load current (1500 mA)
- $V_{IN}$ : Maximum input voltage in application
- $L$ : Min inductor value including worst case tolerances (30% drop can be considered for method 1)
- $f$ : Minimum switching frequency (1.6 MHz)
- $V_{OUT}$ : Output voltage

#### Method 2:

A more conservative and recommended approach is to choose an inductor that has saturation current rating greater than the max current limit of 2.1A.

A 2.2 μH inductor with a saturation current rating of at least 1150 mA is recommended for most applications. The inductor's resistance should be less than 0.3Ω for good efficiency. *Table 1* lists suggested inductors and suppliers. For low-cost applications, an unshielded bobbin inductor could be considered. For noise critical applications, a toroidal or shielded bobbin inductor should be used. A good practice is to lay out the board with overlapping footprints of both types for design flexibility. This allows substitution of a low-noise shielded inductor, in the event that noise from low-cost bobbin models is unacceptable.

#### INPUT CAPACITOR SELECTION

A ceramic input capacitor of 10 μF, 6.3V is sufficient for most applications. Place the input capacitor as close as possible to the  $V_{IN}$  pin of the device. A larger value may be used for improved input voltage filtering. Use X7R or X5R types, do not use Y5V. DC bias characteristics of ceramic capacitors must be considered when selecting case sizes like 0805 and 0603. The input filter capacitor supplies current to the PFET switch of the converter in the first half of each cycle and reduces voltage ripple imposed on the input power source. A ceramic capacitor's low ESR provides the best noise filtering of the input voltage spikes due to this rapidly changing current. Select a capacitor with sufficient ripple current rating. The input current ripple can be calculated as:

$$I_{RMS} = I_{OUTMAX} * \sqrt{\frac{V_{OUT}}{V_{IN}} * \left( 1 - \frac{V_{OUT}}{V_{IN}} + \frac{r^2}{12} \right)}$$

$$r = \frac{(V_{IN} - V_{OUT}) * V_{OUT}}{L * f * I_{OUTMAX} * V_{IN}}$$

The worst case is when  $V_{IN} = 2 * V_{OUT}$

TABLE 1. Suggested Suppliers

Vendor	Dimensions LxWxH (mm)	D.C.R (Max)
Toko	2.8 x 3.0 x 1.2	70 mΩ
Toko	3.0 x 3.0 x 1.2	160 mΩ
Coilcraft	3.76 x 4.2 x 1.8	70 mΩ
Coilcraft	4.45 x 6.6 x 2.92	70 mΩ
Coilcraft	3.3 x 3.3 x 1.4	200 mΩ

#### OUTPUT CAPACITOR SELECTION

Use a 10 μF, 6.3V ceramic capacitor. Use X7R or X5R types, do not use Y5V. DC bias characteristics of ceramic capacitors must be considered when selecting case sizes like 0805 and 0603. DC bias characteristics vary from manufacturer to manufacturer and dc bias curves should be requested from them as part of the capacitor selection process. The output filter capacitor smoothes out current flow from the inductor to the load, helps maintain a steady output voltage during transient load changes and reduces output voltage ripple. These capacitors must be selected with sufficient capacitance and sufficiently low ESR to perform these functions.

The output voltage ripple is caused by the charging and discharging of the output capacitor and also due to its ESR and can be calculated as:

Voltage peak-to-peak ripple due to capacitance can be expressed as follows

$$V_{PP-C} = \frac{I_{RIPPLE}}{4 * f * C}$$

Voltage peak-to-peak ripple due to ESR can be expressed as follows

$$V_{PP-ESR} = (2 * I_{RIPPLE}) * R_{ESR}$$





## Application Hints (Continued)

Because these two components are out of phase the rms value can be used to get an approximate value of peak-to-peak ripple.

Voltage peak-to-peak ripple, root mean squared can be expressed as follows

$$V_{PP-RMS} = \sqrt{V_{PP-C}^2 + V_{PP-ESR}^2}$$

**TABLE 2. Suggested Capacitor and their Suppliers**

Model	Type	Vendor	Voltage	Case Size Inch (mm)
<b>10 <math>\mu</math>F</b>				
GRM21BR60J106K	Ceramic, X5R	Murata	6.3V	0805 (2012)
JMK212BJ106K	Ceramic, X5R	Taiyo-Yuden	6.3V	0805 (2012)
C2012X5R0J106K	Ceramic, X5R	TDK	6.3V	0805 (2012)

## Board Layout Considerations

PC board layout is an important part of DC-DC converter design. Poor board layout can disrupt the performance of a DC-DC converter and surrounding circuitry by contributing to EMI, ground bounce, and resistive voltage loss in the traces. These can send erroneous signals to the DC-DC converter IC, resulting in poor regulation or instability.

Good layout for the converters can be implemented by following a few simple design rules.

1. Place the converters, inductor and filter capacitors close together and make the traces short. The traces between these components carry relatively high switching currents and act as antennas. Following this rule reduces radiated noise. Special care must be given to place the input filter capacitor very close to the  $V_{IN}$  and GND pin.
2. Arrange the components so that the switching current loops curl in the same direction. During the first half of each cycle, current flows from the input filter capacitor through the converter and inductor to the output filter capacitor and back through ground, forming a current loop. In the second half of each cycle, current is pulled up from ground through the converter by the inductor to the output filter capacitor and then back through ground forming a second current loop. Routing these loops so the current curls in the same direction prevents magnetic field reversal between the two half-cycles and reduces radiated noise.
3. Connect the ground pins of the converter and filter capacitors together using generous component-side cop-

Note that the output voltage ripple is dependent on the inductor current ripple and the equivalent series resistance of the output capacitor ( $R_{ESR}$ ).

The  $R_{ESR}$  is frequency dependent (as well as temperature dependent); make sure the value used for calculations is at the switching frequency of the part.

per fill as a pseudo-ground plane. Then, connect this to the ground-plane (if one is used) with several vias. This reduces ground-plane noise by preventing the switching currents from circulating through the ground plane. It also reduces ground bounce at the converter by giving it a low-impedance ground connection.

4. Use wide traces between the power components and for power connections to the DC-DC converter circuit. This reduces voltage errors caused by resistive losses across the traces.
5. Route noise sensitive traces, such as the voltage feedback path, away from noisy traces between the power components. The voltage feedback trace must remain close to the converter circuit and should be direct but should be routed opposite to noisy components. This reduces EMI radiated onto the DC-DC converter's own voltage feedback trace. A good approach is to route the feedback trace on another layer and to have a ground plane between the top layer and layer on which the feedback trace is routed. In the same manner for the adjustable part it is desired to have the feedback dividers on the bottom layer.
6. Place noise sensitive circuitry, such as radio RF blocks, away from the DC-DC converter, CMOS digital blocks and other noisy circuitry. Interference with noise-sensitive circuitry in the system can be reduced through distance.



**Physical Dimensions** inches (millimeters) unless otherwise noted

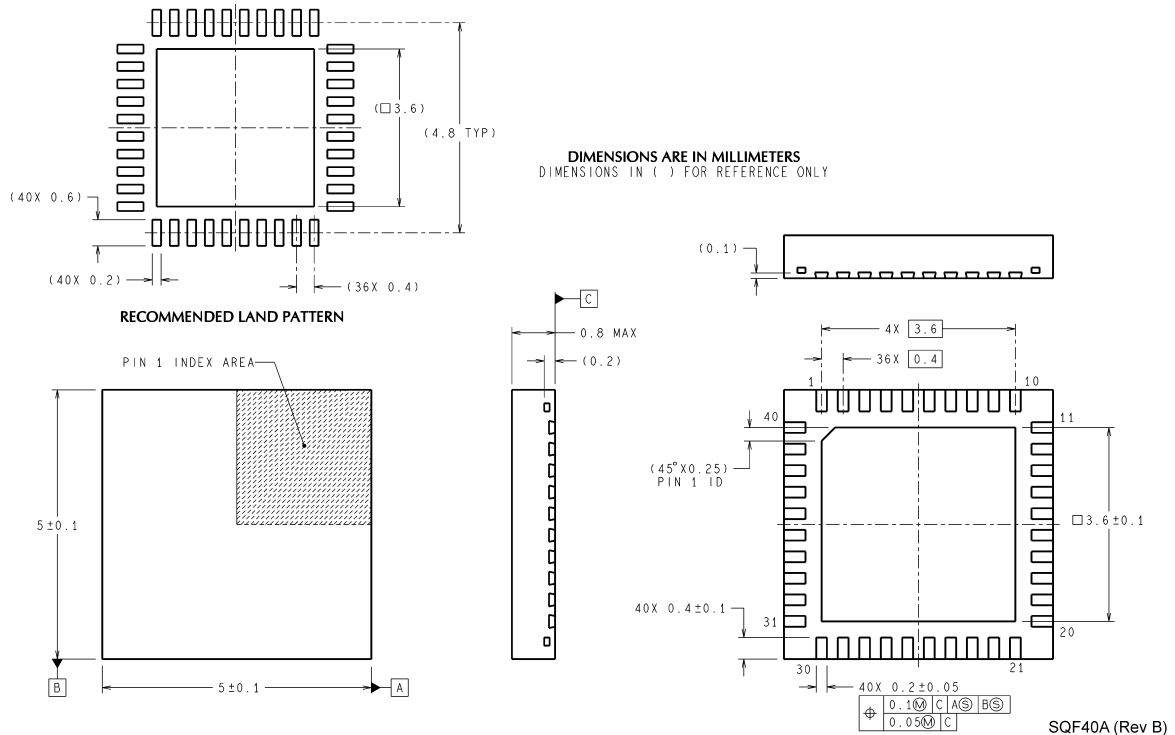

National does not assume any responsibility for use of any circuitry described, no circuit patent licenses are implied and National reserves the right at any time without notice to change said circuitry and specifications.

For the most current product information visit us at [www.national.com](http://www.national.com).

**LIFE SUPPORT POLICY**

NATIONAL'S PRODUCTS ARE NOT AUTHORIZED FOR USE AS CRITICAL COMPONENTS IN LIFE SUPPORT DEVICES OR SYSTEMS WITHOUT THE EXPRESS WRITTEN APPROVAL OF THE PRESIDENT AND GENERAL COUNSEL OF NATIONAL SEMICONDUCTOR CORPORATION. As used herein:

1. Life support devices or systems are devices or systems which, (a) are intended for surgical implant into the body, or (b) support or sustain life, and whose failure to perform when properly used in accordance with instructions for use provided in the labeling, can be reasonably expected to result in a significant injury to the user.
2. A critical component is any component of a life support device or system whose failure to perform can be reasonably expected to cause the failure of the life support device or system, or to affect its safety or effectiveness.

**BANNED SUBSTANCE COMPLIANCE**

National Semiconductor manufactures products and uses packing materials that meet the provisions of the Customer Products Stewardship Specification (CSP-9-111C2) and the Banned Substances and Materials of Interest Specification (CSP-9-111S2) and contain no "Banned Substances" as defined in CSP-9-111S2.

Leadfree products are RoHS compliant.

**National Semiconductor  
Americas Customer  
Support Center**  
Email: [new.feedback@nsc.com](mailto:new.feedback@nsc.com)  
Tel: 1-800-272-9959

**National Semiconductor  
Europe Customer Support Center**  
Fax: +49 (0) 180-530 85 86  
Email: [europe.support@nsc.com](mailto:europe.support@nsc.com)  
Deutsch Tel: +49 (0) 69 9508 6208  
English Tel: +44 (0) 870 24 0 2171  
Français Tel: +33 (0) 1 41 91 8790

**National Semiconductor  
Asia Pacific Customer  
Support Center**  
Email: [ap.support@nsc.com](mailto:ap.support@nsc.com)

**National Semiconductor  
Japan Customer Support Center**  
Fax: 81-3-5639-7507  
Email: [jpn.feedback@nsc.com](mailto:jpn.feedback@nsc.com)  
Tel: 81-3-5639-7560

