

TOSHIBA

2SC5411

TOSHIBA TRANSISTOR SILICON NPN TRIPLE DIFFUSED MESA TYPE

2SC5411

HORIZONTAL DEFLECTION OUTPUT FOR HIGH RESOLUTION DISPLAY, COLOR TV

HIGH SPEED SWITCHING APPLICATIONS

- High Voltage : $V_{CB0} = 1500\text{ V}$
- Low Saturation Voltage : $V_{CE(sat)} = 3\text{ V (Max.)}$
- High Speed : $t_f = 0.15\ \mu\text{s (Typ.)}$
- Collector Metal (Fin) is Fully Covered with Mold Resin.

MAXIMUM RATINGS ($T_a = 25^\circ\text{C}$)

CHARACTERISTIC	SYMBOL	RATING	UNIT
Collector-Base Voltage	V_{CB0}	1500	V
Collector-Emitter Voltage	V_{CEO}	600	V
Emitter-Base Voltage	V_{EBO}	5	V
Collector Current	DC	I_C	14
	Pulse	I_{CP}	28
Base Current	I_B	7	A
Collector Power Dissipation ($T_c = 25^\circ\text{C}$)	P_C	60	W
Junction Temperature	T_j	150	$^\circ\text{C}$
Storage Temperature Range	T_{stg}	-55~150	$^\circ\text{C}$

Unit in mm

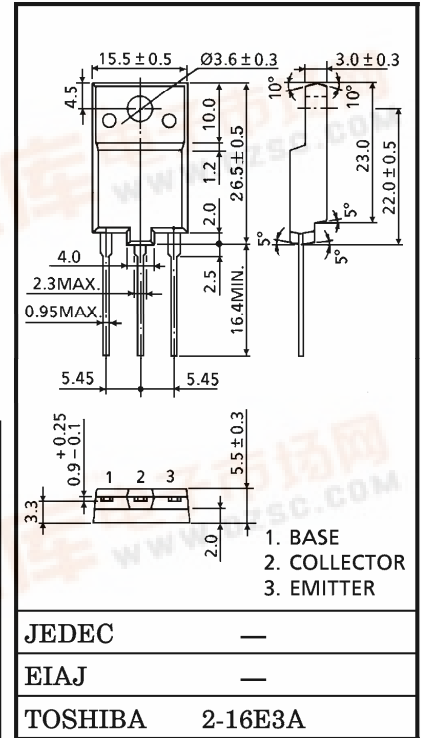

JEDEC	—
EIAJ	—
TOSHIBA	2-16E3A

Weight : 5.5 g (Typ.)

961001EAA1

- TOSHIBA is continually working to improve the quality and the reliability of its products. Nevertheless, semiconductor devices in general can malfunction or fail due to their inherent electrical sensitivity and vulnerability to physical stress. It is the responsibility of the buyer, when utilizing TOSHIBA products, to observe standards of safety, and to avoid situations in which a malfunction or failure of a TOSHIBA product could cause loss of human life, bodily injury or damage to property. In developing your designs, please ensure that TOSHIBA products are used within specified operating ranges as set forth in the most recent products specifications. Also, please keep in mind the precautions and conditions set forth in the TOSHIBA Semiconductor Reliability Handbook.
- The information contained herein is presented only as a guide for the applications of our products. No responsibility is assumed by TOSHIBA CORPORATION for any infringements of intellectual property or other rights of the third parties which may result from its use. No license is granted by implication or otherwise under any intellectual property or other rights of TOSHIBA CORPORATION or others.
- The information contained herein is subject to change without notice.

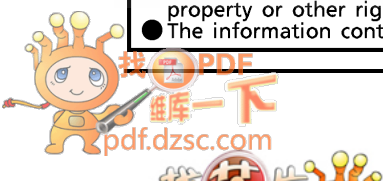

ELECTRICAL CHARACTERISTICS (Ta = 25°C)

CHARACTERISTIC		SYMBOL	TEST CONDITION	MIN.	TYP.	MAX.	UNIT
Collector Cut-off Current		I_{CBO}	$V_{CB} = 1500 \text{ V}, I_E = 0$	—	—	1	mA
Emitter Cut-off Current		I_{EBO}	$V_{EB} = 5 \text{ V}, I_C = 0$	—	—	10	μA
Emitter-Base Breakdown Voltage		$V_{(BR)CEO}$	$I_C = 10 \text{ mA}, I_B = 0$	600	—	—	V
DC Current Gain		$h_{FE(1)}$	$V_{CE} = 5 \text{ V}, I_C = 2 \text{ A}$	10	—	40	
		$h_{FE(2)}$	$V_{CE} = 5 \text{ V}, I_C = 11 \text{ A}$	4	—	8	
Collector-Emitter Saturation Voltage		$V_{CE(sat)}$	$I_C = 11 \text{ A}, I_B = 2.75 \text{ A}$	—	—	3	V
Base-Emitter Saturation Voltage		$V_{BE(sat)}$	$I_C = 11 \text{ A}, I_B = 2.75 \text{ A}$	—	1.0	1.5	V
Transition Frequency		f_T	$V_{CE} = 10 \text{ V}, I_C = 0.1 \text{ A}$	—	2	—	MHz
Collector Output Capacitance		C_{ob}	$V_{CB} = 10 \text{ V}, I_E = 0, f = 1 \text{ MHz}$	—	190	—	pF
Switching Time	Storage Time	t_{stg}	$I_{CP} = 8.5 \text{ A}, I_{B1}(\text{end}) = 1.6 \text{ A}$ $f_H = 64 \text{ kHz}$	—	2.5	3.5	μs
	Fall Time	t_f		—	0.15	0.3	



