



BIPOLAR ANALOG INTEGRATED CIRCUIT

μ PC1394C

SWITCHING REGULATOR IC FOR TV SET

The μ PC1394C is a switching regulator IC especially designed for TV sets. It can be used for both type of TV sets, insulated type and no insulated type.
 It operates in synchronizing with the horizontal retrace pulse, so does not generate any visual noise in the picture on CRT.
 The output transistor in a powersupply circuit is protected doubly by the internal protection circuit for over load.
 ON/OFF operation of the powersupply is able to be operated easily without any mechanical relay using provided terminal. So timer operation, remote control and etc. are very easy.

FEATURES

- Wide range of regulating input line voltage.
: AC 80 to 280 V
- The output power transistor is doubly protected by the current limiter and the shut down circuit.
- No visual noise due to horizontal synchronous operation.
- A terminal for remote control, timer operation and etc. of the powersupply is provided.
- Shut down circuit is easily resetable using ON/OFF terminal.
- Low stand-by and starting current. (2 mA)

PACKAGE DIMENSIONS in millimeters

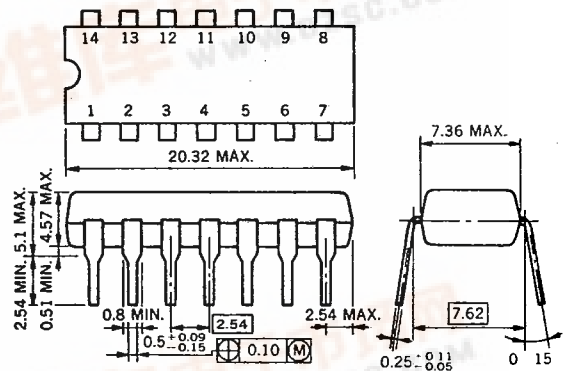

BLOCK DIAGRAM

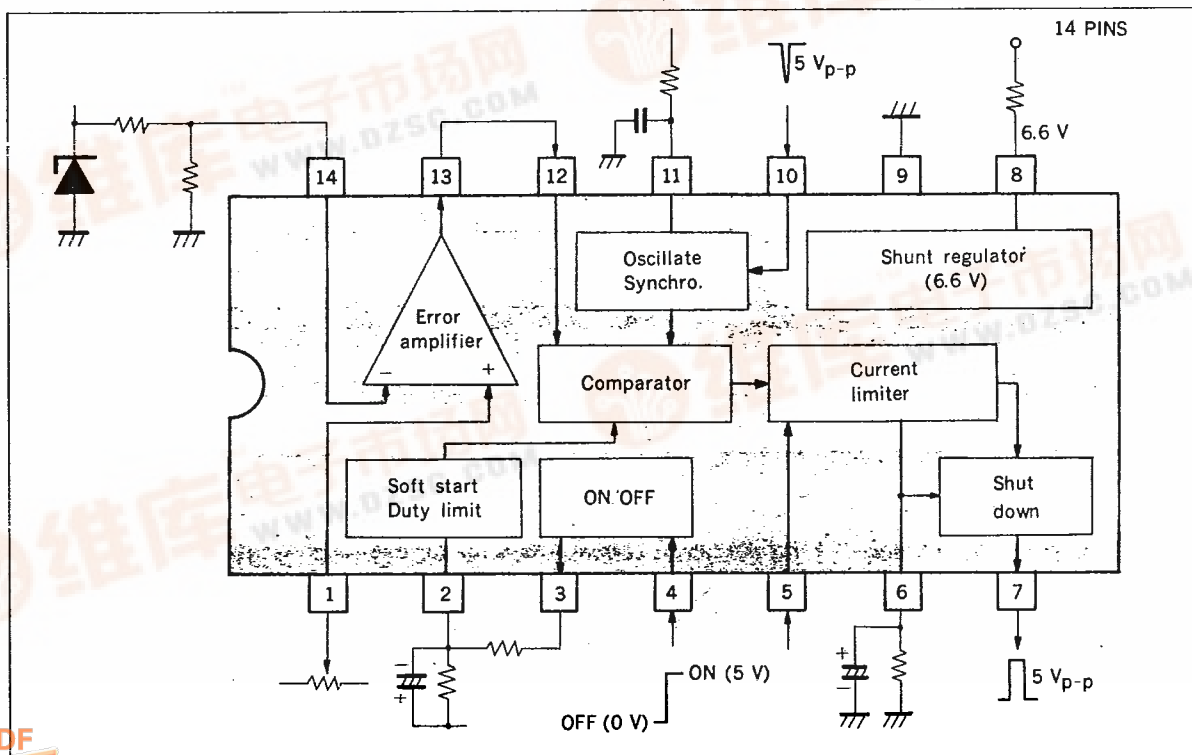

ABSOLUTE MAXIMUM RATINGS (T_a = 25 °C)

Supply Current	I ₈	30	mA
Sink of Output Terminal	I ₇	10	mA
Input Voltage of Current Limiter	V ₅	3.0	V
Input Voltage of ON/OFF Circuit	V ₄	V ₈	V
Sink of ON/OFF Circuit	I ₃	1.5	mA
Input Voltage of Duty Limit Circuit	V ₂	V ₈	V
Input Voltage of Synchronous Circuit	V ₁₀	-5 to V ₈	V
External Oscillation Resistor	R _o	5 to ∞	kΩ
External Oscillation Capacitor	C _o	0 to 1	μF
Input Voltage of Error Amplifier	V ₁	V ₈	V
Reference Voltage	V ₁₄	V ₈	V
Drain of Error Amplifier	I ₁₃	-2 to 0	mA
Input Voltage of Shut Down Circuit	V ₁₂	V ₈	V
Integration Voltage of Shut Down Circuit	V ₆	V ₈	V
Power Dissipation	P _D	150 (T _a = 75 °C)	mW
Operating Temperature	T _{opt}	-20 to +75	°C
Storage Temperature	T _{stg}	-40 to +125	°C

ELECTRICAL CHARACTERISTICS (T_a = 25 °C)

CHARACTERISTICS	SYMBOL	CONDITION	MIN.	TYP.	MAX.	UNIT
Supply Terminal Voltage	V ₈	I ₈ = 12 mA	6.1	6.6	7.1	V
Thermal Drift of V ₈	dV ₈ (T _a)	Difference of MIN. and MAX. of V ₈ in T _a from -20 °C to +75 °C			200	mV
Starting Supply Current (1)	I ₈ (1)	V ₈ = 3 V, Pin 7 : Open		1.0	1.5	mA
Starting Supply Current (2)	I ₈ (2)	V ₈ = 3 V, Pin 7 : Ground		3.0	4.2	mA
Starting Pulse Height	P ₇ (S)	V ₈ = 3 V, Pin 7 : Open, Pin 6 : Ground	1.5	2.3	3.0	V _{p-p}
Starting Supply Terminal Voltage	V ₈ (S)	Pin 7 : Open, Pulse of Pin 7 = 1.5 V _{p-p}	2.0	2.6	3.0	V
Starting Oscillation Frequency	f _o (S)	V ₈ = 3 V, Pin 10 : Open	10	13	20	kHz
Output Pulse Height	P ₇	Pin 7 : Open, Pin 6 : Ground	5.0	6.0	7.1	V _{p-p}
Drain of Output Terminal	I ₇	Pin 7 : Ground, V ₂ = V ₈	-6.3	-5.0	-3.7	mA
Saturation Voltage of Output Terminal	V ₇ (sat)	I ₇ = 5 mA			0.3	V
Integration Terminal Current (1)	I ₆ (1)	I ₅ = 100 μA	-700	-500	-300	μA
Integration Terminal Current (2)	I ₆ (2)	V ₅ = 0.8 V	-700	-500	-300	μA
Leak of Integration Terminal	-I _{6L}	V ₅ = 0.3 V	-10		0	μA
Trigger Voltage of Shut Down Circuit	V _{6T}	P ₇ < 100 mV _{p-p}	2.5		3.5	V
Drain of Duty Limit Terminal	I ₂	V ₂ = 3 V	-20		0	μA
Pulse Width set by Pin 2 Voltage	P _L	V = 2.33 V, frequency : 15.75 kHz, Low level period	25	30	35	μs
Thermal Drift of P _L	dP _L (T _a)	V ₂ = 2.33 V, Difference of MIN. and MAX. of P _L in T _a from -20 °C to +75 °C			2	μs
ON Voltage of Pin 4	V ₄ (ON)	I ₃ = 3 mA, V ₃ = 0.3 V	1.5	2.5	3.5	V
ON Current of Pin 4	I ₄ (ON)	I ₃ = 3 mA, V ₃ = 0.3 V			200	μA
Output Saturation of ON/OFF Circuit	V ₃ (sat)	I ₃ = 3 mA, V ₄ = 3.5 V			300	mV
Leak of ON/OFF Output	I _{3L}	V ₄ = 1.5 V, V ₃ = V ₈			1	μA
Offset Voltage of Error Amplifier	V(OS)	Absolute Value		8	20	mV
Opened Gain of Error Amplifier	A _{VO}	f : 1 kHz, Signal of Pin 13 : 1 V _{p-p}	45	53	80	dB
Current of Pin 1	I ₁	Pin 1 : Ground			-10	μA



CHARACTERISTICS	SYMBOL	CONDITION	MIN.	TYP.	MAX.	UNIT
Current of Pin 14	I_{14}	Pin 14 : Ground			-10	μA
Maximum Voltage of Error Amplifier Output	$V_{13(MAX.)}$	$V_1 = 3.5 V, V_{14} = 3.0 V$	5.0	5.7		V
Minimum Voltage of Error Amplifier Output	$V_{13(MIN.)}$	$V_1 = 2.5 V, V_{14} = 3.0 V$		50	300	mV
Sink of Error Amplifier Output	I_{13}	$V_1 = 2.5 V, V_{14} = 3.0 V, V_{13} = 3.0 V$	50	100	250	μA
Free Running Oscillation Amplitude	V_{fo}	Pin 10 : Open	V_{so}	3.3	4.0	V_{p-p}
Starting Oscillation Amplitude	$V_{fo(S)}$	$V_8 = 3.0 V$	0.5	1.5		V_{p-p}
Free Running Oscillation Frequency	f_o	Pin 10 : Open	12.3	13.3	14.3	kHz
Thermal Drift of f_o	$df_o(T_a)$	Pin 10 : Open, Difference of MIN. and MAX. of f_o in T_a from $-20^\circ C$ to $+75^\circ C$			500	Hz
Synchronous Oscillation Amplitude	V_{so}	Synchronous Frequency : 15.75 kHz	2.7	3.0	3.3	V_{p-p}
Thermal Drift of V_{so}	$dV_{so}(T_a)$	Difference of MIN. and MAX. of V_{so} in T_a from $-20^\circ C$ to $+75^\circ C$			150	mV
High level of Oscillation	V_{OH}			3.8	4.5	V
Starting V_{OH}	$V_{OH(S)}$	$V_8 = 3.0 V$	1.0	1.8		V
Thermal Drift of V_{OH}	$dV_{OH}(T_a)$	Difference of MIN. and MAX. of V_{OH} in T_a from $-20^\circ C$ to $+75^\circ C$			100	mV
Synchronous Signal Voltage	V_s	Oscillation is synchronizing. (15.75 kHz)	-1.0		+0.3	V
Synchronous Signal Current	I_s	Oscillation is synchronizing. (15.75 kHz)	-200	-40		μA

CONNECTION DIAGRAM (Top View)

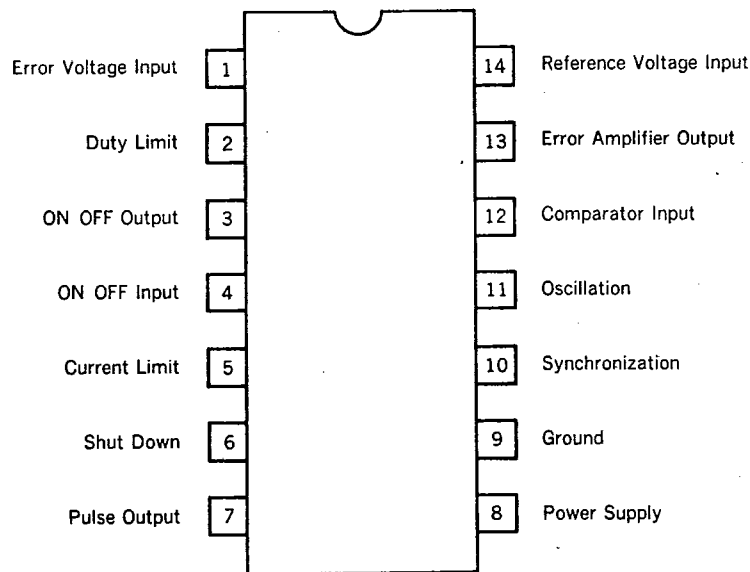

o#1 (Error Voltage Input)

This terminal is an inversion input of error amplifier. A feedback voltage of output is applied to this.

o#2 (Duty Limit)

This terminal is for setting maximum value of output transistor's on time. This value is decided by setting the ratio of the resistance value between terminal 2 and V_{CC} to one between terminal 2 and 3.

This terminal can also be used for soft-start function on applying the primary voltage.

o#3 (ON/OFF Output)

o#4 (ON/OFF Input)

These terminals are used for ON/OFF control of output, so that it is conveniently used for remote control of the power source of the set.

When terminal 3 is low level, the output is on and when it is high, the output is off. It can be directly driven for low active control signal, but for high active signal, it is convenient to use built-in ON/OFF circuit.

o#5 (Current Limit)

This terminal is used for protecting the control transistor from instantaneous overload. As input to this terminal, a waveform similar to emitter current of the output transistor, when operating the over current limiting function, terminal 7 is kept on a high level but a pulse is out again in the next period.

o#6 (Shut Down)

This terminal is used for shutting down the output when the overcurrent limiting function is operated. The voltage of this terminal is rising up gradually when operating the overcurrent limiting function and it rises up certain voltage (about 3 V), shut down function is operated.

If output shut down operation is unnecessary, terminal 6 is grounded.

o#7 (Pulse Output)

This is a Pulse output terminal for controlling the output transistor. The low level is on timing of the controller. Therefore, when overcurrent limit and shut down circuit operate, output is pulled up to high level.

o#8 (Power Supply)

This is a power supply terminal, as a shunt regulator is built in, this terminal can be connected to the primary voltage through a resistance, the recommended range of input current is 10 to 15 mA.

o#9 (Ground)

o#10 (Synchronization)

This terminal is used for synchronizing the operation to external signal. Horizontal fly-back pulse can usually be used for this. When synchronization is not needed, terminal 10 is left open.

o#11 (Oscillation)

o#12 (Comparator Input)

Output of error amplifier is input to this terminal. The change of input voltage is converted to the change of pulse width and it controls the output pulse width of terminal 7.

o#13 (Error Amplifier Output)

o#14 (Reference Voltage Input)

This terminal is a non-inversion input of error amplifier. For reference voltage, it is suitable to divide a zener diode of about 6 V into two. It can be used to the voltage of terminal 8.



EXAMPLE OF APPLICATIONS

1. Isolated type

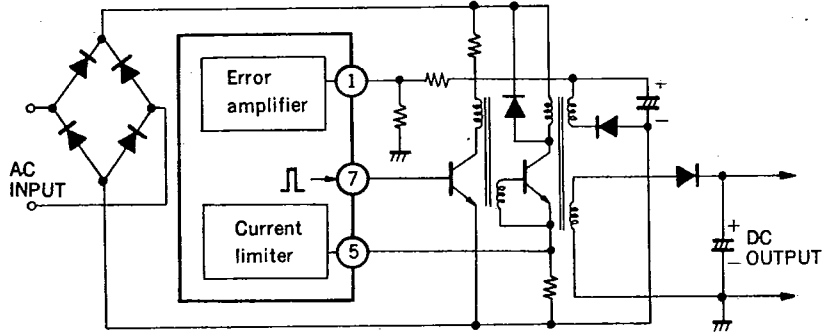

2. No isolated type

2-1 Inverting mode

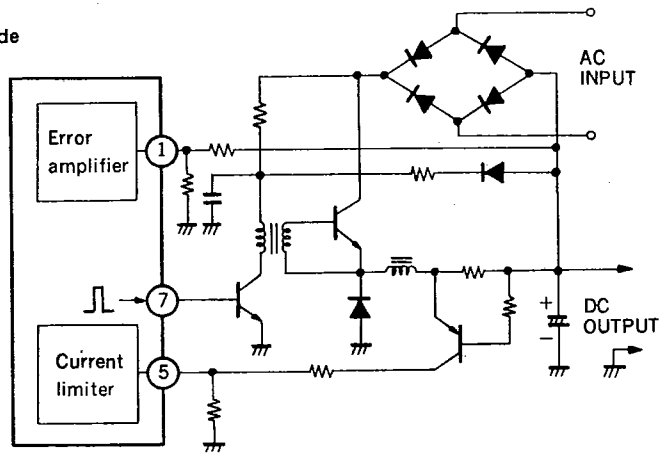

2-2 No inverting mode

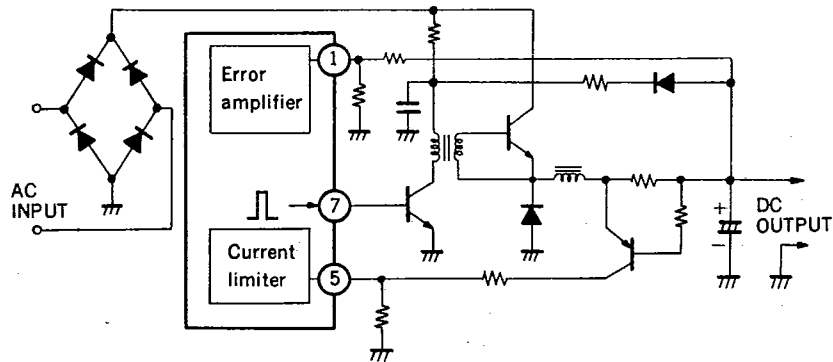

PC1394C

NEC ELECTRON DEVICE

6427525 N E C ELECTRONICS INC

72C 08701 D T-77-07-11

PATTERN OF PRINTED WIRING BOARD (Bottom View)

This printed wiring board is designed for the circuit of application 1

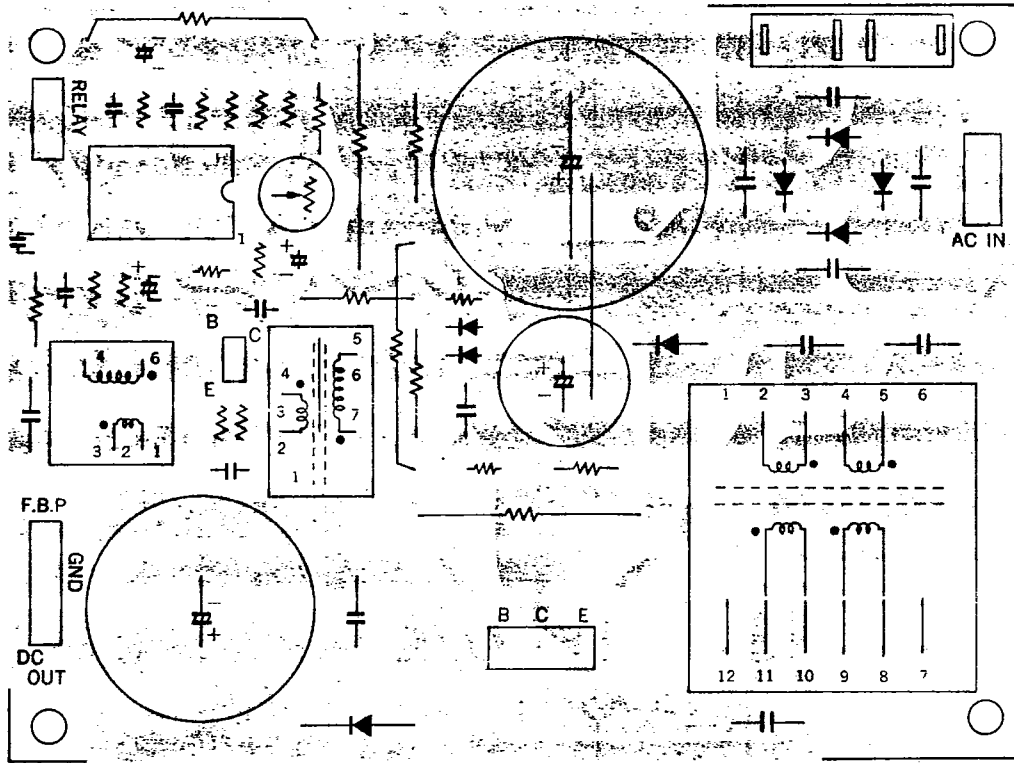

APPLICATION 1 (Isolated type)

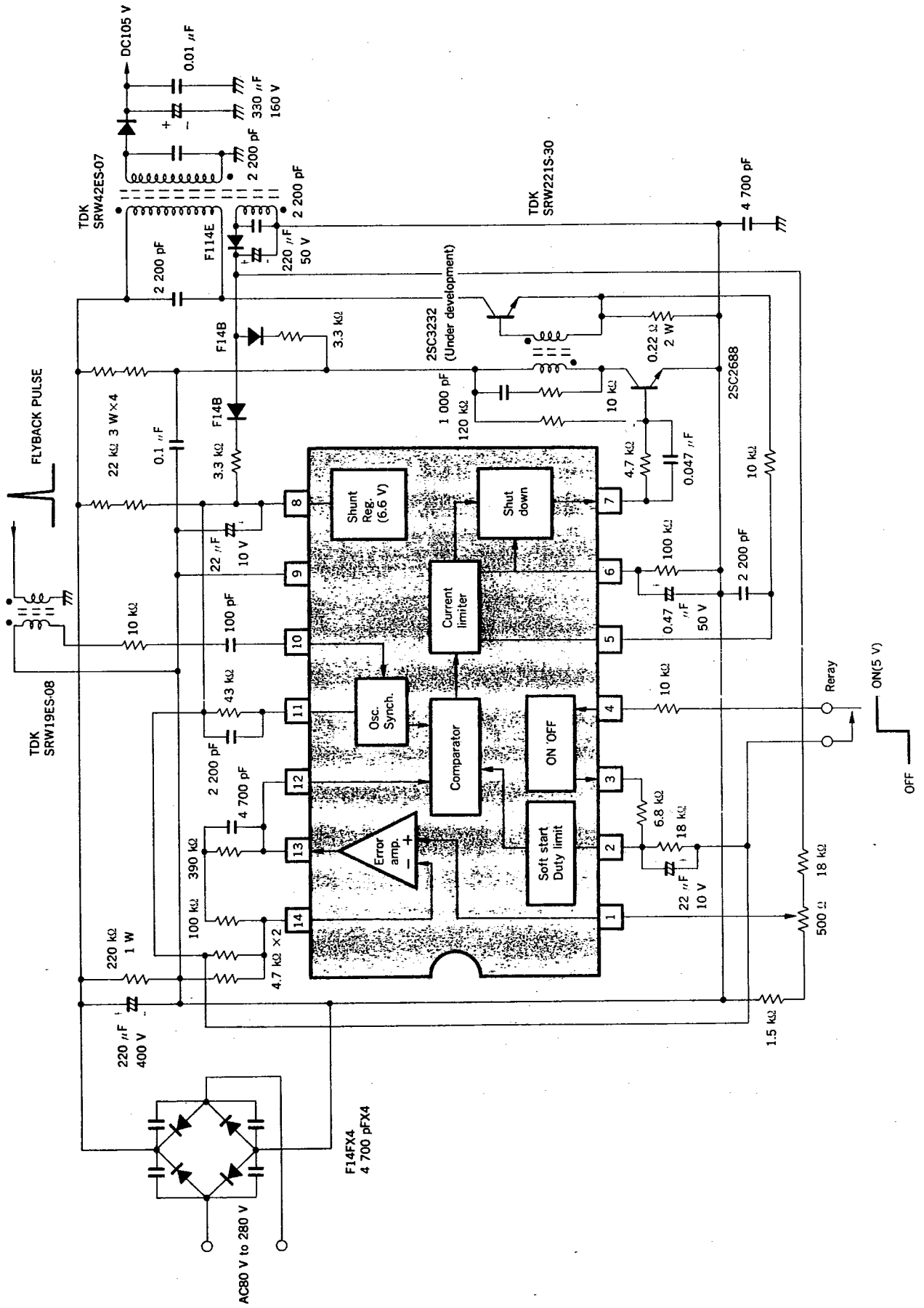

APPLICATION 2 (No Isolated type)

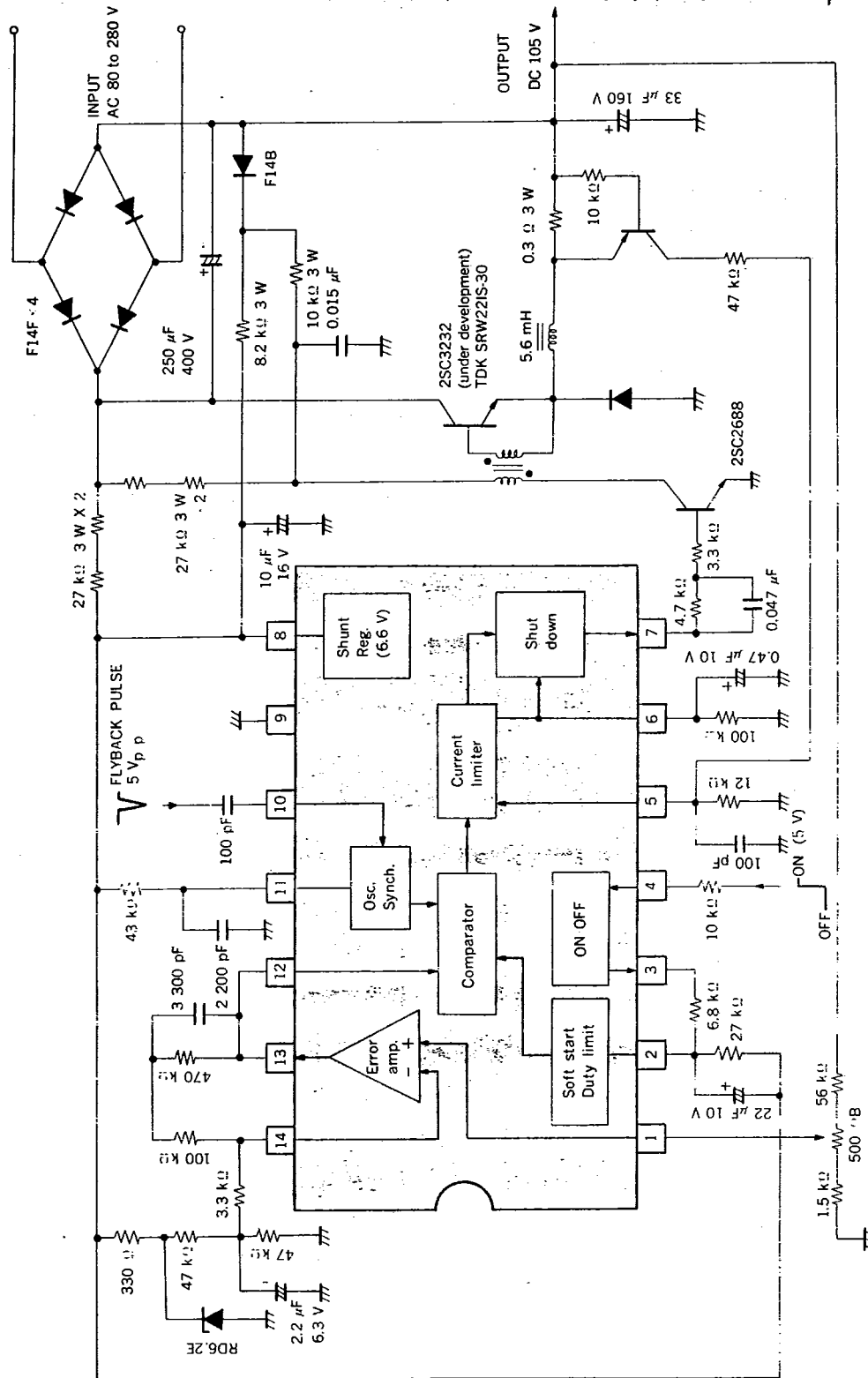

NEC Corporation

INTERNATIONAL ELECTRON DEVICES DIV.
 NEC Building, 33-1, Shiba Gochome
 Minato-ku, Tokyo 108, Japan
 Tel: Tokyo 454-1111
 Telex Address: NECTOK J22686
 Cable Address: MICROPHONE TOKYO

