



The Future of Analog IC Technology™

EV1528DQ-00A

9 Lamp, 20mA Precision WLED Driver Evaluation Board

GENERAL DESCRIPTION

The EV1528DQ-00A evaluation board is designed for driving up to nine (9) series WLEDs from a single cell Lithium Ion battery. The board is set up to obtain 20mA LED current. The current can be adjusted by varying the resistor R1.

The MP1528 uses current limited, variable frequency architecture to regulate the LED current while maintaining high efficiency. The BIAS pin measures the output voltage and turns off the converter if an over voltage condition is present to prevent damage due to an open circuit condition. The LED current is measured with an external current sense resistor. The low 0.4V full-scale regulation threshold and 0.4Ω power switch minimize power loss to improve efficiency. Either a DC voltage or a PWM signal at the BRT input can control the LED brightness.

ELECTRICAL SPECIFICATIONS

Parameter	Symbol	Value	Units
Input Voltage	V_{IN}	2.7 – 5.5	V
# of WLEDs		7 – 9	
LED Current	I_{LED}	20	mA

FEATURES

- 2.7V to 5.5V Input Voltage Range
- Drives up to 9 Series White LEDs
- Analog and Digital PWM Brightness Control Through BRT
- Surface-Mount Components
- Fully Assembled and Tested

APPLICATIONS

- Handheld Computers
- PDAs
- PDA Phones
- Digital and Video Cameras
- Small LCD Displays

"MPS" and "The Future of Analog IC Technology" are Trademarks of Monolithic Power Systems, Inc.

EV1528DQ-00A EVALUATION BOARD



(L x W x H) 2.0" x 1.5" x 0.5"
(5.0cm x 3.8cm x 1.4cm)

Board Number	MPS IC Number
EV1528DQ-00A	MP1528DQ

Efficiency vs Load Current

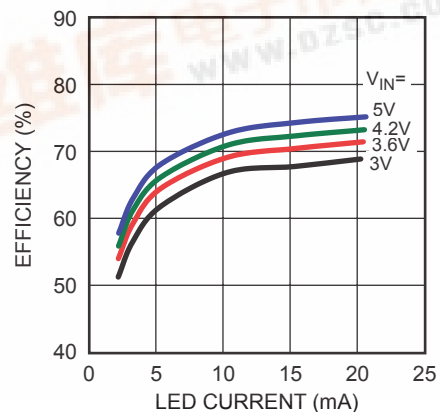

MP1528_EC01

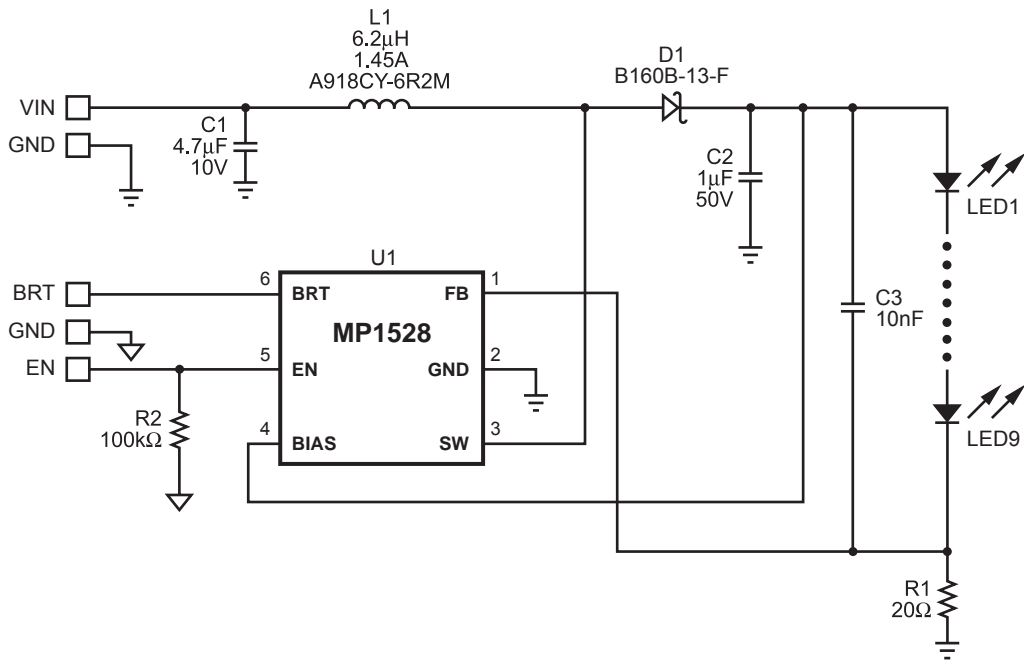
EVALUATION BOARD SCHEMATIC

EV1528_S01

EV1528DQ-00A BILL OF MATERIALS

Qty	Ref	Value	Description	Package	Manufacturer P/N	Distributor P/N
1	C1	4.7µF	Ceramic Capacitor, 10V, X5R	1206	TDK: C3216X5R1A475K	Digikey: 445-1386-1-ND
1	C2	1µF	Ceramic Capacitor, 50V, X7R	1206	TDK: C3216X7R1H105K	Digikey: 445-1423-1-ND
1	C3	10nF	Ceramic Capacitor, 50V, X7R	0805	TDK: C2012X7R1H103K	Digikey: 445-1348-1-ND
1	D1		Diode Schottky, 60V, 1A	SMA	Diodes Inc.: B160B-13-F	Digikey: B160B-FDICT-ND
1	L1	6.2µH	Inductor, 1.45A, D62LCB	SMD	Toko: A918CY-6R2M	
9	LED1 to LED9		Not Stuffed			
1	R1	20Ω	Resistor, 1%	0805	Panasonic: ERJ-6GEYJ200V	Digikey: P20ACT-ND
1	R2	100kΩ	Resistor, 5%	0805	Panasonic: ERJ-6GEYJ104V	Digikey: P100KACT-ND
1	U1		White LED Driver	QFN6	MPS: MP1528DQ	

PRINTED CIRCUIT BOARD LAYOUT

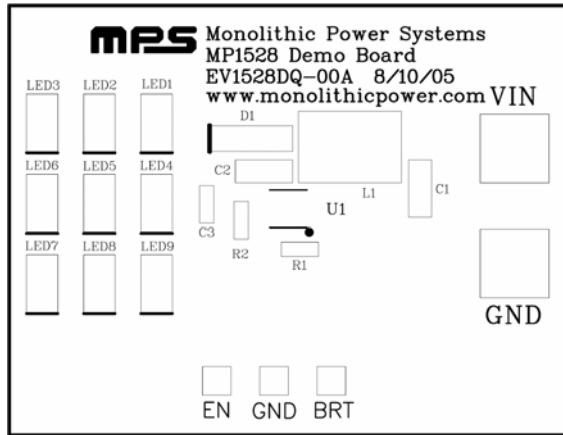

Figure 1—Top Silk Layer

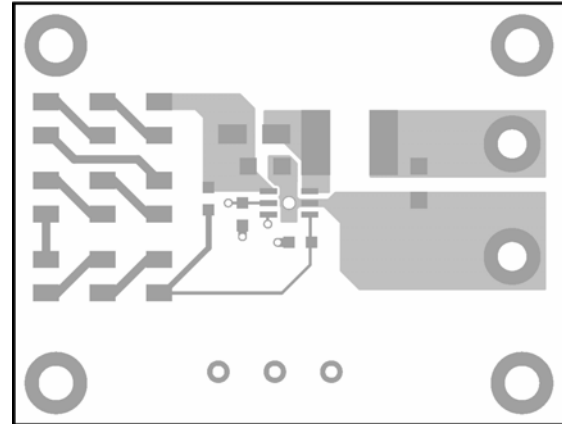

Figure 2—Top Layer

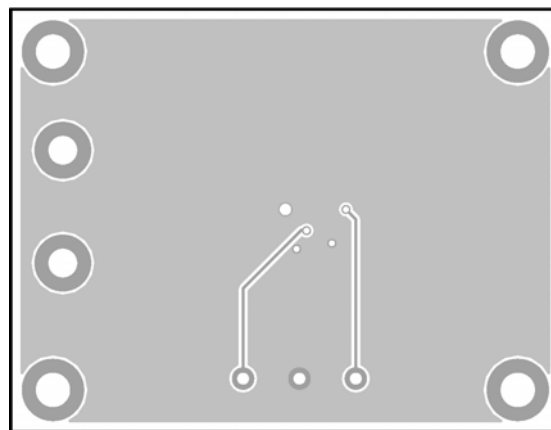

Figure 3—Bottom Layer

QUICK START GUIDE

1. Solder LED1 - LED9 to the board.
2. Attach the positive and negative terminals of the power supply (2.7V - 5.5V) to the VIN and GND pins, respectively.
3. Drive EN high to enable the MP1528.
4. Apply a DC voltage of 0.3V to 1.2V on BRT for analog dimming. Maximum brightness (20mA typical) occurs with 1.2V applied. For PWM dimming mode, apply a PWM rectangular wave with a minimum voltage less than 0.18V and a maximum greater than 1.2V. When a voltage less than 0.18V is applied to this pin, the output switch is turned off. The frequency of the PWM signal must be between 100Hz to 400Hz.

NOTICE: The information in this document is subject to change without notice. Please contact MPS for current specifications. Users should warrant and guarantee that third party Intellectual Property rights are not infringed upon when integrating MPS products into any application. MPS will not assume any legal responsibility for any said applications.