



MOTOROLA

MC1350

Monolithic IF Amplifier

The MC1350 is an integrated circuit featuring wide range AGC for use as an IF amplifier in radio and TV over an operating temperature range of 0° to +75°C.

- Power Gain: 50 dB Typ at 45 MHz
50 dB Typ at 58 MHz
- AGC Range: 60 dB Min, DC to 45 MHz
- Nearly Constant Input & Output Admittance over the Entire AGC Range
- γ_{21} Constant (-3.0 dB) to 90 MHz
- Low Reverse Transfer Admittance: $\ll 1.0 \mu\text{mho Typ}$
- 12 V Operation, Single-Polarity Power Supply

IF AMPLIFIER

SEMICONDUCTOR TECHNICAL DATA

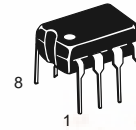

P SUFFIX
PLASTIC PACKAGE
CASE 626

D SUFFIX
PLASTIC PACKAGE
CASE 751
(SO-8)

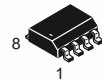

MAXIMUM RATINGS ($T_A = +25^\circ\text{C}$, unless otherwise noted.)

Rating	Symbol	Value	Unit
Power Supply Voltage	V+	+18	Vdc
Output Supply Voltage	V ₁ , V ₈	+18	Vdc
AGC Supply Voltage	V _{AGC}	V+	Vdc
Differential Input Voltage	V _{in}	5.0	Vdc
Power Dissipation (Package Limitation)	P _D	625	mW
Plastic Package		5.0	mW/°C
Derate above 25°C			
Operating Temperature Range	T _A	0 to +75	°C

ORDERING INFORMATION

Device	Operating Temperature Range	Package
MC1350P	T _A = 0° to +75°C	Plastic DIP
MC1350D		SO-8

Figure 1. Typical MC1350 Video IF Amplifier and MC1330 Low-Level Video Detector Circuit

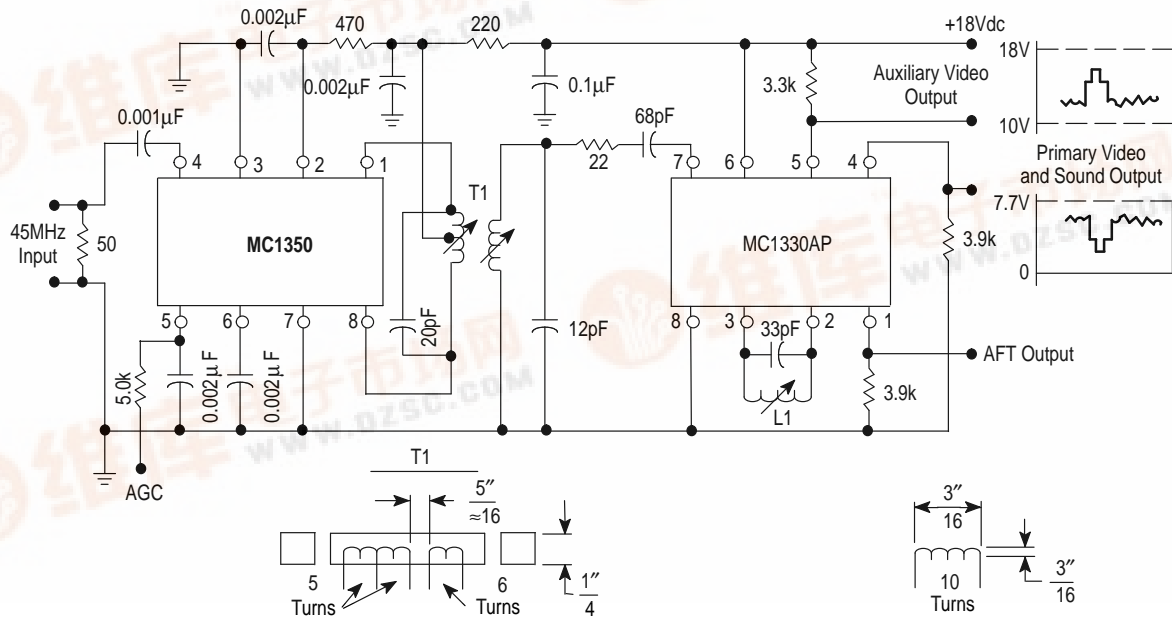

All windings #30 AWG tinned nylon acetate wire tuned with Carbonyl E or J slugs.

L1 wound with #26 AWG tinned nylon acetate wire tuned by distorting winding.



MC1350

ELECTRICAL CHARACTERISTICS ($V^+ = +12$ Vdc, $T_A = +25^\circ\text{C}$, unless otherwise noted.)

Characteristics	Symbol	Min	Typ	Max	Unit
AGC Range, 45 MHz (5.0 V to 7.0 V) (Figure 1)		60	68	–	dB
Power Gain (Pin 5 grounded via a 5.1 k Ω resistor) f = 58 MHz, BW = 4.5 MHz See Figure 6(a) f = 45 MHz, BW = 4.5 MHz See Figure 6(a), (b) f = 10.7 MHz, BW = 350 kHz See Figure 7 f = 455 kHz, BW = 20 kHz	A_p	– 46 – –	48 50 58 62	– – – –	dB
Maximum Differential Voltage Swing 0 dB AGC –30 dB AGC	V_O	– –	20 8.0	– –	V_{pp}
Output Stage Current (Pins 1 and 8)	$I_1 + I_8$	–	5.6	–	mA
Total Supply Current (Pins 1, 2 and 8)	I_S	–	14	17	mAdc
Power Dissipation	P_D	–	168	204	mW

DESIGN PARAMETERS, Typical Values ($V^+ = +12$ Vdc, $T_A = +25^\circ\text{C}$, unless otherwise noted.)

Parameter	Symbol	Frequency				Unit
		455 kHz	10.7 MHz	45 MHz	58 MHz	
Single-Ended Input Admittance	g_{11} b_{11}	0.31 0.022	0.36 0.50	0.39 2.30	0.5 2.75	mmho
Input Admittance Variations with AGC (0 dB to 60 dB)	Δg_{11} Δb_{11}	– –	– –	60 0	– –	μmho
Differential Output Admittance	g_{22} b_{22}	4.0 3.0	4.4 110	30 390	60 510	μmho
Output Admittance Variations with AGC (0 dB to 60 dB)	Δg_{22} Δb_{22}	– –	– –	4.0 90	– –	μmho
Reverse Transfer Admittance (Magnitude)	$ y_{12} $	$\ll 1.0$	$\ll 1.0$	$\ll 1.0$	$\ll 1.0$	μmho
Forward Transfer Admittance Magnitude Angle (0 dB AGC) Angle (–30 dB AGC)	$ y_{21} $ $\angle y_{21}$ $\angle y_{21}$	160 –5.0 –3.0	160 –20 –18	200 –80 –69	180 –105 –90	mmho Degrees Degrees
Single-Ended Input Capacitance	C_{in}	7.2	7.2	7.4	7.6	pF
Differential Output Capacitance	C_O	1.2	1.2	1.3	1.6	pF

Figure 2. Typical Gain Reduction

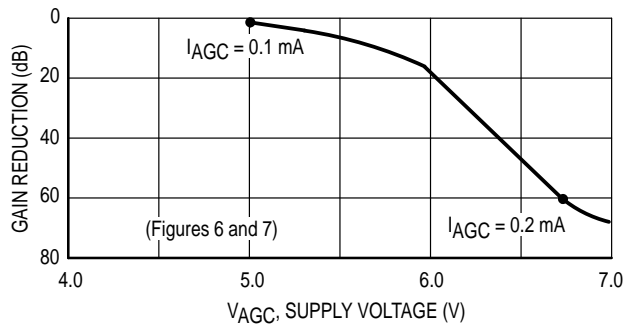
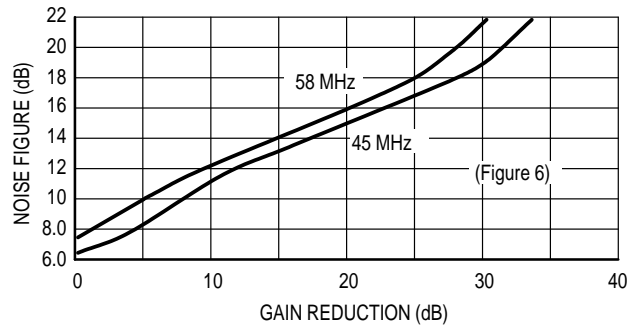

Figure 3. Noise Figure versus Gain Reduction



MC1350

GENERAL OPERATING INFORMATION

The input amplifiers (Q1 and Q2) operate at constant emitter currents so that input impedance remains independent of AGC action. Input signals may be applied single-ended or differentially (for ac) with identical results. Terminals 4 and 6 may be driven from a transformer, but a dc path from either terminal to ground is not permitted.

AGC action occurs as a result of an increasing voltage on the base of Q4 and Q5 causing these transistors to conduct more heavily thereby shunting signal current from the interstage amplifiers Q3 and Q6. The output amplifiers are supplied from an active current source to maintain constant quiescent bias thereby holding output admittance nearly constant. Collector voltage for the output amplifier must be supplied through a center-tapped tuning coil to Pins 1 and 8. The 12 V supply (V+) at Pin 2 may be used for this purpose, but output admittance remains more nearly constant if a separate 15 V supply (V+ +) is used, because the base voltage on the output amplifier varies with AGC bias.

Figure 4. Circuit Schematic

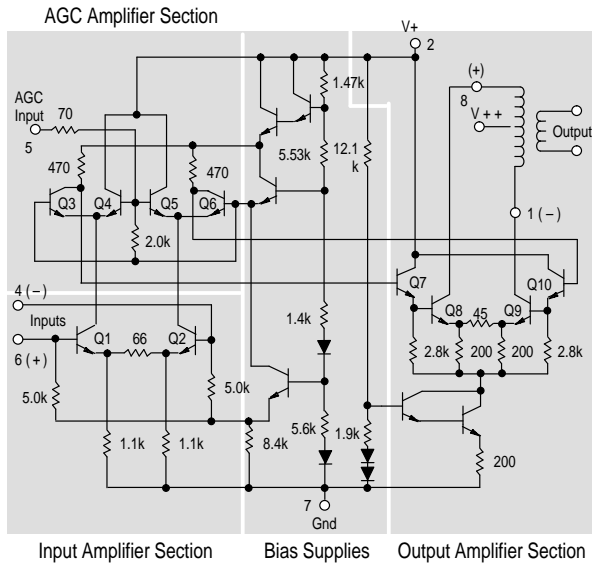

Figure 5. Frequency Response Curve (45 MHz and 58 MHz)

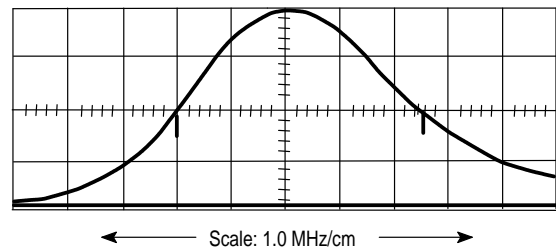
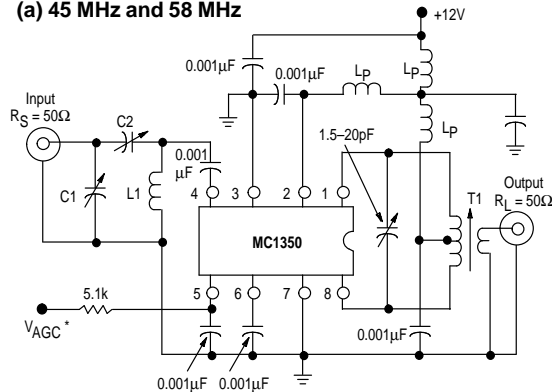
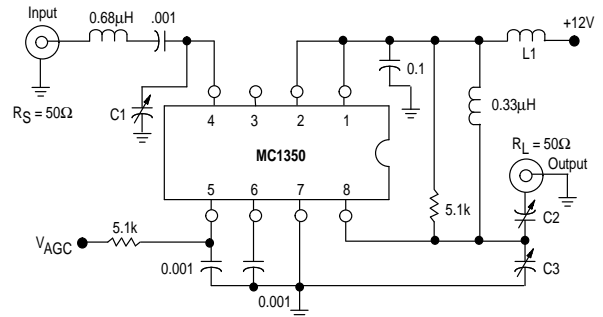

Figure 6. Power Gain, AGC and Noise Figure Test Circuits

(a) 45 MHz and 58 MHz



(b) Alternate 45 MHz



*Connect to ground for maximum power gain test.
All power supply chokes (Lp), are self-resonant at input frequency. $L_p \geq 20 \text{ k}\Omega$.
See Figure 5 for Frequency Response Curve.

L1 @ 45 MHz = 7 1/4 Turns on a 1/4" coil form
@ 58 MHz = 6 Turns on a 1/4" coil form
T1 Primary Winding = 18 Turns on a 1/4" coil form, center-tapped, #25 AWG
Secondary Winding = 2 Turns centered over Primary Winding @ 45 MHz
= 1 Turn @ 58 MHz
Slug = Carbonyl E or J

Ferrite Core 14 Turns 28 S.W.G.	
L1	
C1	5-25 pF
C2	5-25 pF
C3	5-25 pF

	45 MHz		58 MHz	
L1	0.4 μH	Q ≥ 100	0.3 μH	Q ≥ 100
T1	1.3 μH to 3.4 μH	Q ≥ 100 @ 2.0 μH	1.2 μH to 3.8 μH	Q ≥ 100 @ 2.0 μH
C1	50 pF to 160 pF		8.0 pF to 60 pF	
C2	8.0 pF to 60 pF		3.0 pF to 35 pF	

MC1350

Figure 7. Power Gain and AGC Test Circuit (455 kHz and 10.7 MHz)

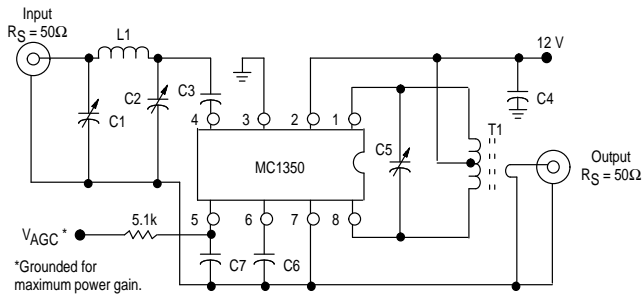

Component	Frequency	
	455 kHz	10.7 MHz
C1	—	80–450 pF
C2	—	5.0–80 pF
C3	0.05 μF	0.001 μF
C4	0.05 μF	0.05 μF
C5	0.001 μF	36 pF
C8	0.05 μF	0.05 μF
C7	0.05 μF	0.05 μF
L1	—	4.6 μH
T1	Note 1	Note 2

NOTES: 1. Primary: 120 μH (center-tapped)
 $Q_U = 140$ at 455 kHz
 Primary: Secondary turns ratio ≈ 13
 2. Primary: 6.0 μH
 Primary winding = 24 turns #36 AWG (close-wound on 1/4" dia. form)
 Core = Carbonyl E or J
 Secondary winding = 1–1/2 turns #36 AWG, 1/4" dia. (wound over center-tap)

Figure 8. Single-Ended Input Admittance

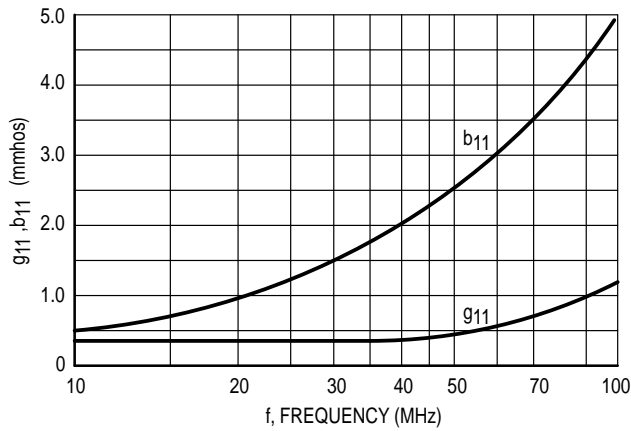

Figure 9. Forward Transfer Admittance

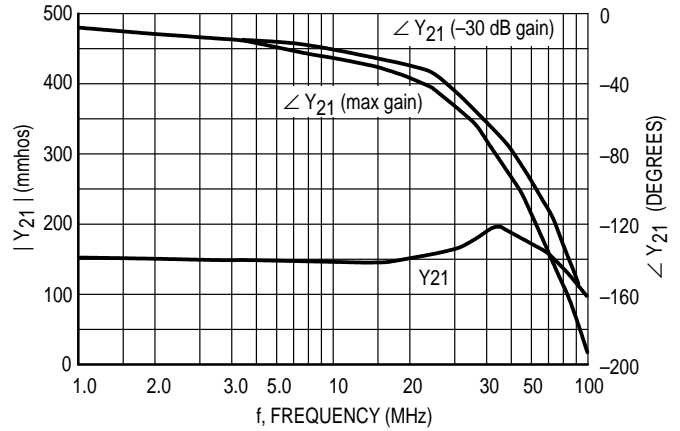

Figure 10. Differential Output Admittance

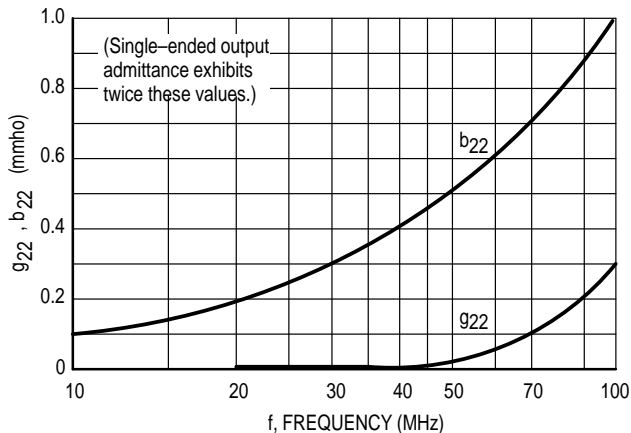
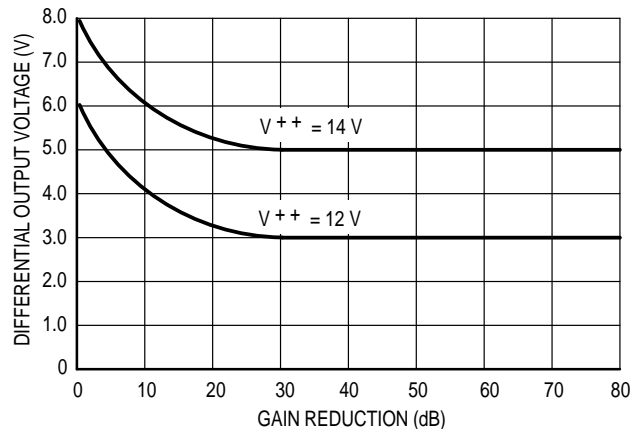

Figure 11. Differential Output Voltage



MC1350

OUTLINE DIMENSIONS

P SUFFIX PLASTIC PACKAGE CASE 626-05 ISSUE K

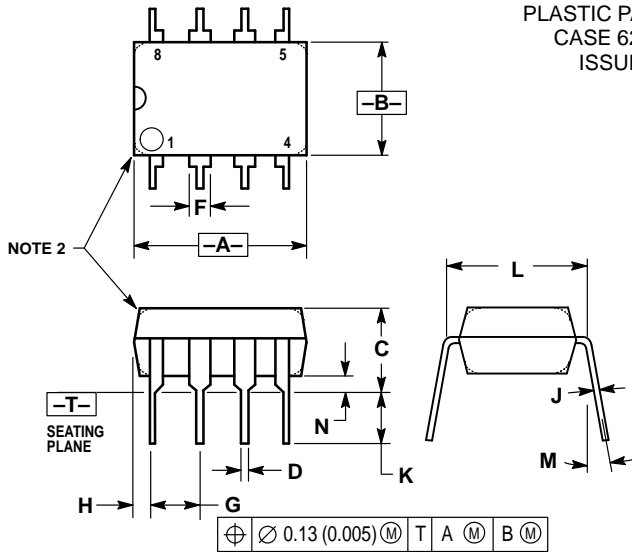

NOTES:

1. DIMENSION L TO CENTER OF LEAD WHEN FORMED PARALLEL.
2. PACKAGE CONTOUR OPTIONAL (ROUND OR SQUARE CORNERS).
3. DIMENSIONING AND TOLERANCING PER ANSI Y14.5M, 1982.

DIM	MILLIMETERS		INCHES	
	MIN	MAX	MIN	MAX
A	9.40	10.16	0.370	0.400
B	6.10	6.60	0.240	0.260
C	3.94	4.45	0.155	0.175
D	0.38	0.51	0.015	0.020
F	1.02	1.78	0.040	0.070
G	2.54 BSC		0.100 BSC	
H	0.76	1.27	0.030	0.050
J	0.20	0.30	0.008	0.012
K	2.92	3.43	0.115	0.135
L	7.62 BSC		0.300 BSC	
M	—		10°	
N	0.76	1.01	0.030	0.040

D SUFFIX PLASTIC PACKAGE CASE 751-05 (SO-8) ISSUE N

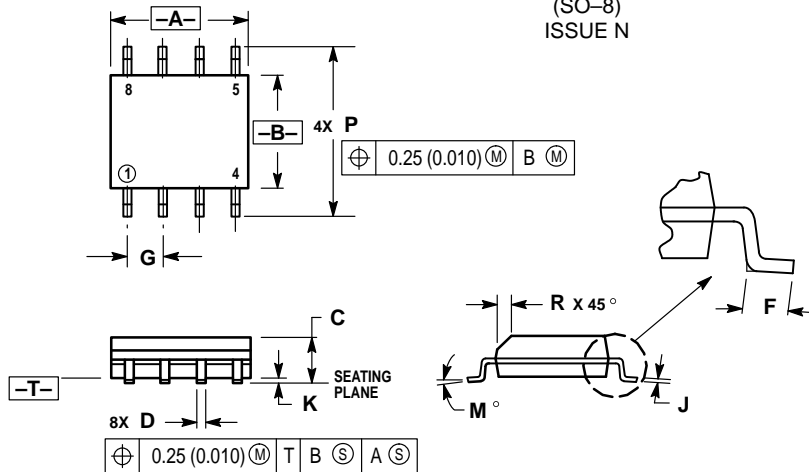

NOTES:

1. DIMENSIONING AND TOLERANCING PER ANSI Y14.5M, 1982.
2. CONTROLLING DIMENSION: MILLIMETER.
3. DIMENSIONS A AND B DO NOT INCLUDE MOLD PROTRUSION.
4. MAXIMUM MOLD PROTRUSION 0.15 (0.006) PER SIDE.
5. DIMENSION D DOES NOT INCLUDE DAMBAR PROTRUSION. ALLOWABLE DAMBAR PROTRUSION SHALL BE 0.127 (0.005) TOTAL IN EXCESS OF THE D DIMENSION AT MAXIMUM MATERIAL CONDITION.

DIM	MILLIMETERS		INCHES	
	MIN	MAX	MIN	MAX
A	4.80	5.00	0.189	0.196
B	3.80	4.00	0.150	0.157
C	1.35	1.75	0.054	0.068
D	0.35	0.49	0.014	0.019
F	0.40	1.25	0.016	0.049
G	1.27 BSC		0.050 BSC	
J	0.18	0.25	0.007	0.009
K	0.10	0.25	0.004	0.009
M	0°		7°	
P	5.80	6.20	0.229	0.244
R	0.25	0.50	0.010	0.019



MC1350

Motorola reserves the right to make changes without further notice to any products herein. Motorola makes no warranty, representation or guarantee regarding the suitability of its products for any particular purpose, nor does Motorola assume any liability arising out of the application or use of any product or circuit, and specifically disclaims any and all liability, including without limitation consequential or incidental damages. "Typical" parameters which may be provided in Motorola data sheets and/or specifications can and do vary in different applications and actual performance may vary over time. All operating parameters, including "Typicals" must be validated for each customer application by customer's technical experts. Motorola does not convey any license under its patent rights nor the rights of others. Motorola products are not designed, intended, or authorized for use as components in systems intended for surgical implant into the body, or other applications intended to support or sustain life, or for any other application in which the failure of the Motorola product could create a situation where personal injury or death may occur. Should Buyer purchase or use Motorola products for any such unintended or unauthorized application, Buyer shall indemnify and hold Motorola and its officers, employees, subsidiaries, affiliates, and distributors harmless against all claims, costs, damages, and expenses, and reasonable attorney fees arising out of, directly or indirectly, any claim of personal injury or death associated with such unintended or unauthorized use, even if such claim alleges that Motorola was negligent regarding the design or manufacture of the part. Motorola and  registered trademarks of Motorola, Inc. Motorola, Inc. is an Equal Opportunity/Affirmative Action Employer.

How to reach us:

USA/EUROPE/Locations Not Listed: Motorola Literature Distribution;
P.O. Box 20912; Phoenix, Arizona 85036. 1-800-441-2447 or 602-303-5454

MFAX: RMFAX0@email.sps.mot.com – TOUCHTONE 602-244-6609

INTERNET: <http://Design-NET.com>

JAPAN: Nippon Motorola Ltd.; Tatsumi-SPD-JLDC, 6F Seibu-Butsuryu-Center,
3-14-2 Tatsumi Koto-Ku, Tokyo 135, Japan. 03-81-3521-8315

ASIA/PACIFIC: Motorola Semiconductors H.K. Ltd.; 8B Tai Ping Industrial Park,
51 Ting Kok Road, Tai Po, N.T., Hong Kong. 852-26629298

