

SIM300

Application Note

Difference Between SIM300 and SIM100S

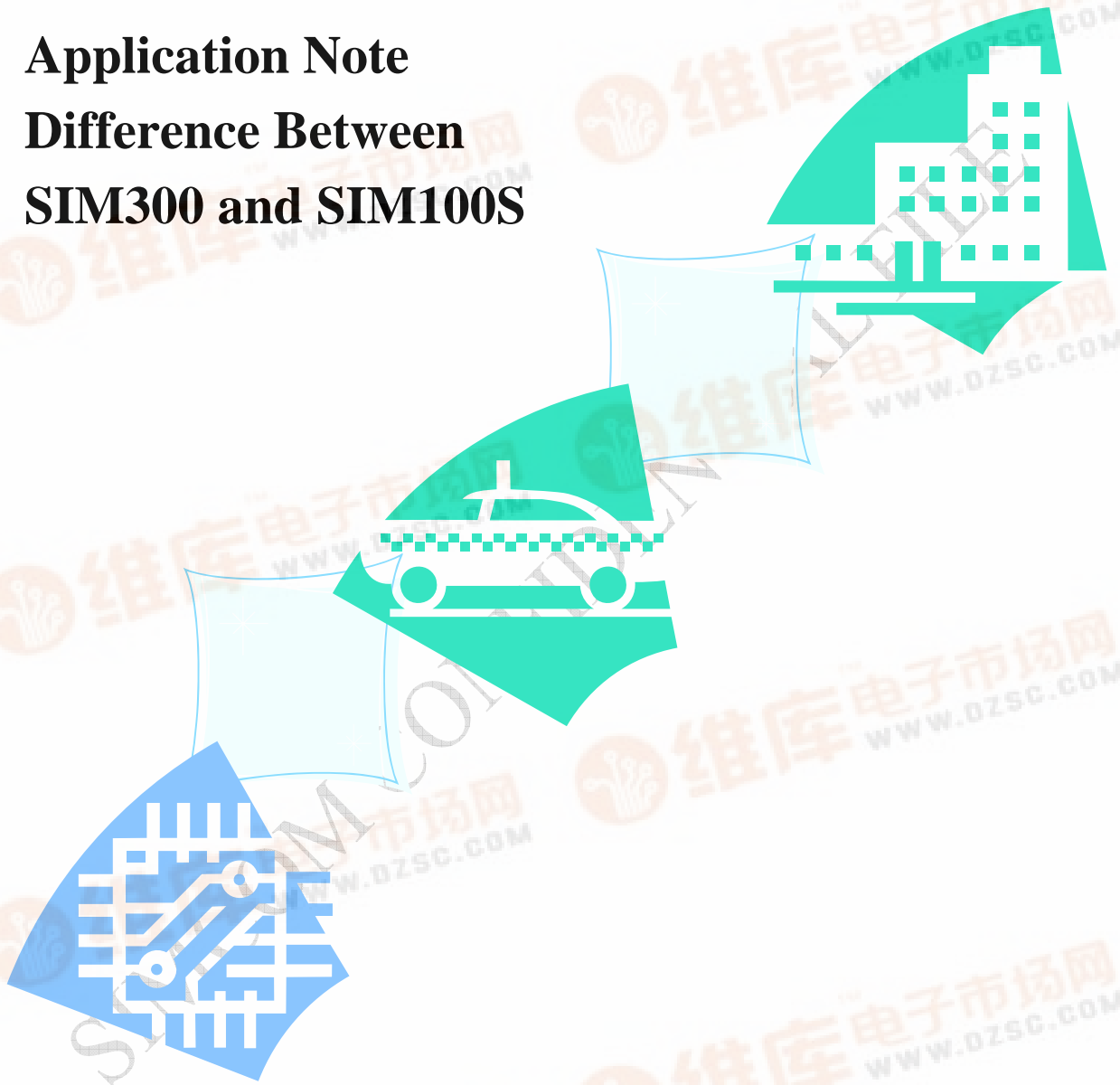

SIMCOM Ltd.,
21th Dec 2005



Difference between SIM300 and SIM100S

Confidential

SIMCOM

Document Name:	Difference between SIM300 and SIM100S
Version:	01.02
Date:	2005-12-21
Doc Id:	SIM300_AN_01_V1.02
Status:	Release

General Notes

Simcom offers this information as a service to its customers, to support application and engineering efforts that use Simcom products. The information provided is based upon requirements specifically provided to Simcom by the customers. Simcom has not undertaken any independent search for additional relevant information, including any information that may be in the customer's possession. Furthermore, system validation of this Simcom product within a larger electronic system remains the responsibility of the customer or the customer's system integrator. All specifications supplied herein are subject to change.

Copyright

This document contains proprietary technical information which is the property of SIMCOM Limited., copying of this document and giving it to others and the using or communication of the contents thereof, are forbidden without express authority. Offenders are liable to the payment of damages. All rights reserved in the event of grant of a patent or the registration of a utility model or design. All specification supplied herein are subject to change without notice at any time.

Copyright © SIMCOM Limited. 2005



Contents

Contents	2
Version History	3
1. Introduction.....	4
2. Product concept.....	4
3. The part of power on circuit.....	4
4. The serial port and software upgrade	5
5. GPIO and BUZZER	5
6. SIM card.....	6
7. Audio circuit.....	8
8. Power supply and the others	9

Figure Index

FIGURE 1: POWER ON CIRCUIT	5
FIGURE 2: GPIO INTERFACE.....	6
FIGURE 3: REFERENCE CIRCUIT OF 8PIN SIM CARD.....	7
FIGURE 4: REFERENCE CIRCUIT OF 6PIN SIM CARD.....	7
FIGURE 5: MICROPHONE CIRCUIT	8
FIGURE 6: SPEAKER CIRCUIT	8
FIGURE 7: SPEAKER CIRCUIT ABOUT AMPLIFIER	9



Version History

Data	Version	Description of change	Author
2005-08-03	01.00	Origin	anthony
2005-12-20	01.01	Modify with SIM300_V2.04	anthony
2005-12-21	01.02	Add the serial port and software upgrade	anthony

SIMCOM CONFIDENTIAL FILE

1. Introduction

This document describes the design reference of the SIMCOM SIM300 module such as design notes, reference circuit and PCB layout reference.

Reference document:

SIM300_HD_V1.05

2. Product concept

Designed for global market, SIM300 is a Tri-band GSM/GPRS engine that works on frequencies EGSM 900 MHz, DCS 1800 MHz and PCS1900 MHz. SIM300 provides GPRS multi-slot class 10 capability and support the GPRS coding schemes CS-1, CS-2, CS-3 and CS-4.

With a tiny configuration of 40mm x 33mm x 2.85 mm , SIM300 can fit almost all the space requirement in your application, such as Smart phone, PDA phone and other mobile device.

The physical interface between SIM300 and the mobile application is through a 60 pins board-to-board connector, which provides all hardware interfaces from module to customers' boards except the RF antenna interface.

- The keypad and SPI LCD interface will give you the flexibility to develop customized applications.
- Two serial ports can help you easily develop your applications.
- Two audio channels include two microphones inputs and two speaker outputs. These audio interfaces can be easily configured by AT command.
- One ADC input
- Two GPIO ports and SIM card detection port

3. The part of power on circuit

You can turn on the module by driving the PWRKEY to a low level voltage for period time. The automatic power on circuit illustrate as following figure. The PWRKEY pin is the NO.34 pin of the module interface. The value of the capacitor C155 is recommended as **330uF/16V**. The diode D2 (1N4148) is used for current discharge when power down. The diode can be modified to the other type part which discharge capability is better. You can make a decision by some experiments yourself.



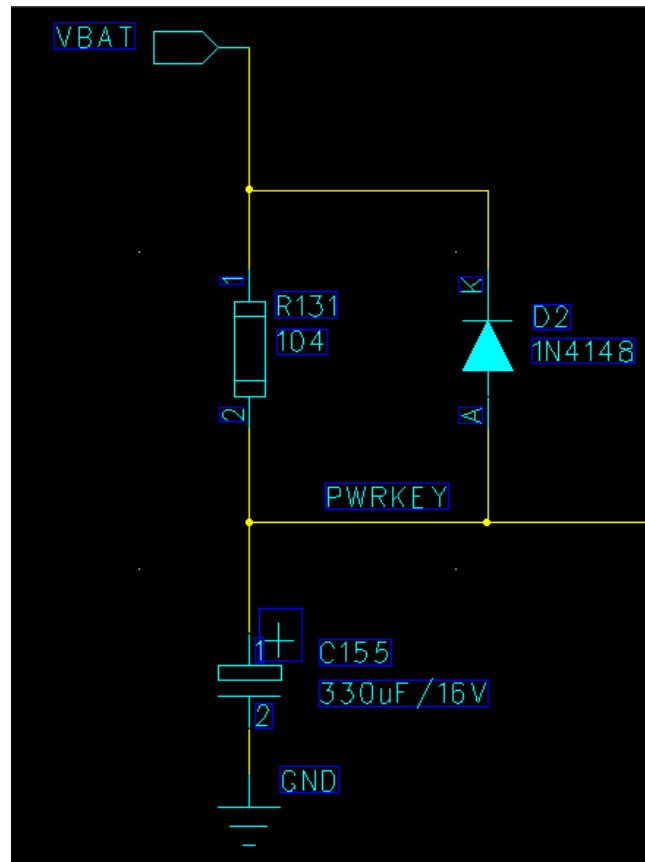

Figure 1: Power on circuit

4. The serial port and software upgrade

The TXD、RXD、DBG_TXD、DBG_RXD、GND must be connected to the IO connector when user need to upgrade software and debug software,the TXD、RXD should be used for software upgrade and the DBG_TXD、DBG_RXD for software debug.The PWRKEY pin is recommended to connect to the IO connector.,the user also can add a switch between the PWRKEY and the GND. The PWRKEY should be connected to the GND when SIM300 is upgrading software. Please refer to SIM300_HD_V1.05 for the detail.

5. GPIO and BUZZER

The PIN36 of the SIM300 is **GPIO8/BUZZER**, but the PIN36 of the SIM100S is RESET. The PIN32 of the SIM300 is **GPIO5**, but the PIN32 of the SIM100S is BUZZER. The two GPIO pins of SIM300 can set by AT command or custom-built software, showed as the following figure.

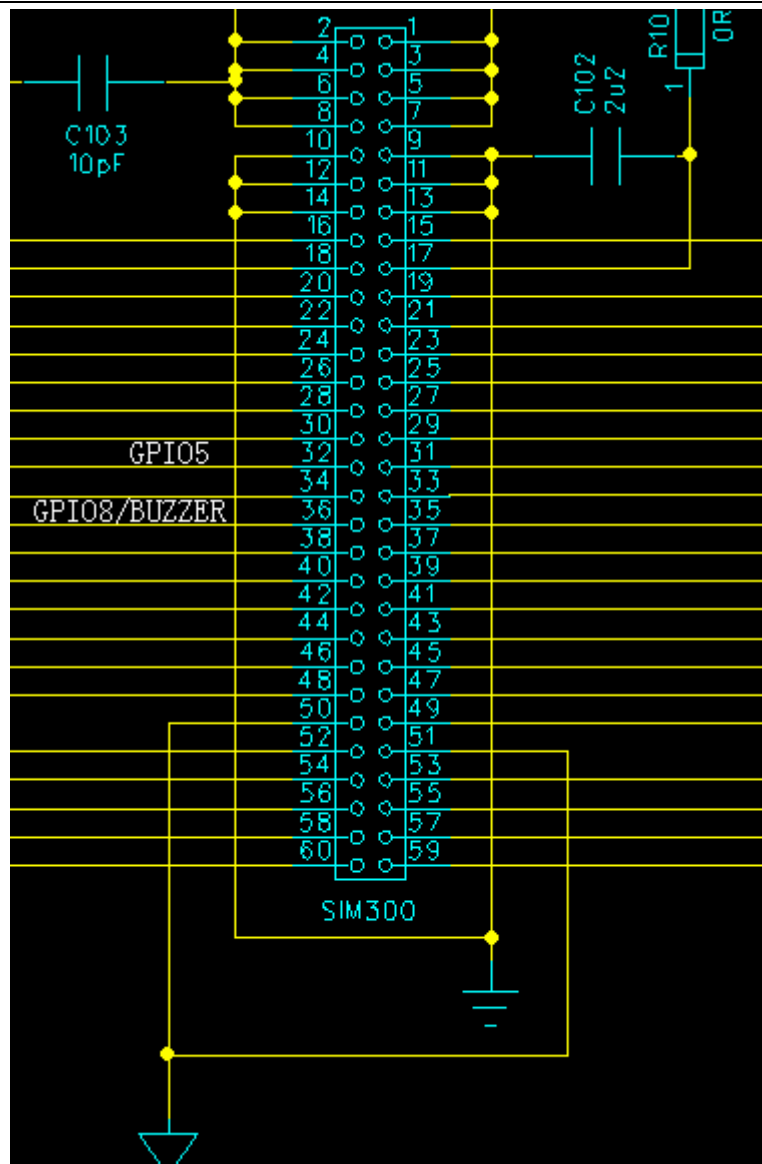

Figure 2: GPIO interface

6. SIM card

Following is the reference circuit about SIM interface. We recommend an Electro-Static discharge device ST (www.st.com) ESDA6V1W5 or ON SEMI (www.onsemi.com) SMF05C for “ESD ANTI”. The resistors (R204-R206) showed in the figure 3 should be added in series on the IO line between the module and the SIM card for matching the impedance. The SIM_PRESENCE pin is used for detecting the SIM card removal.

Note: The pull up resistor R207 must be added.

You can select the 8 pins SIM card. The reference circuit about SIM card illustrates as following figure.



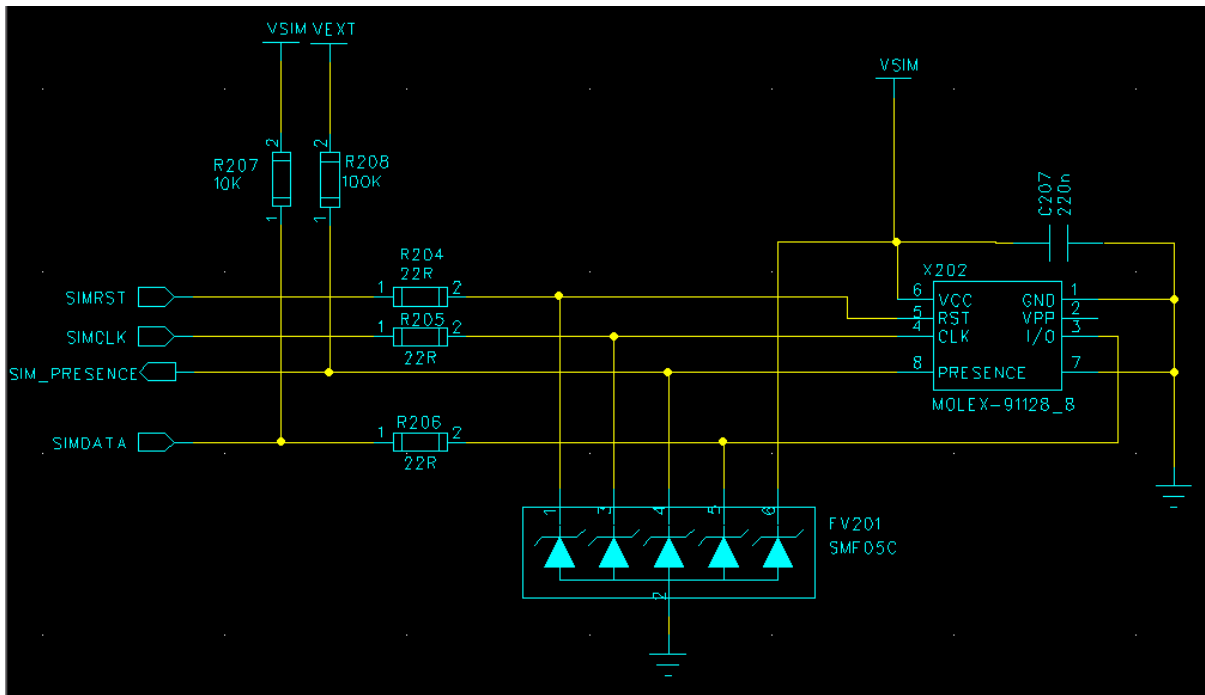

Figure 3: Reference circuit of 8PIN SIM card

If you don't use the SIM card detection function, you can let the SIM_PRESENCE pin NC or connect to the GND. The reference circuit about 6 pins SIM card illustrates as following figure.

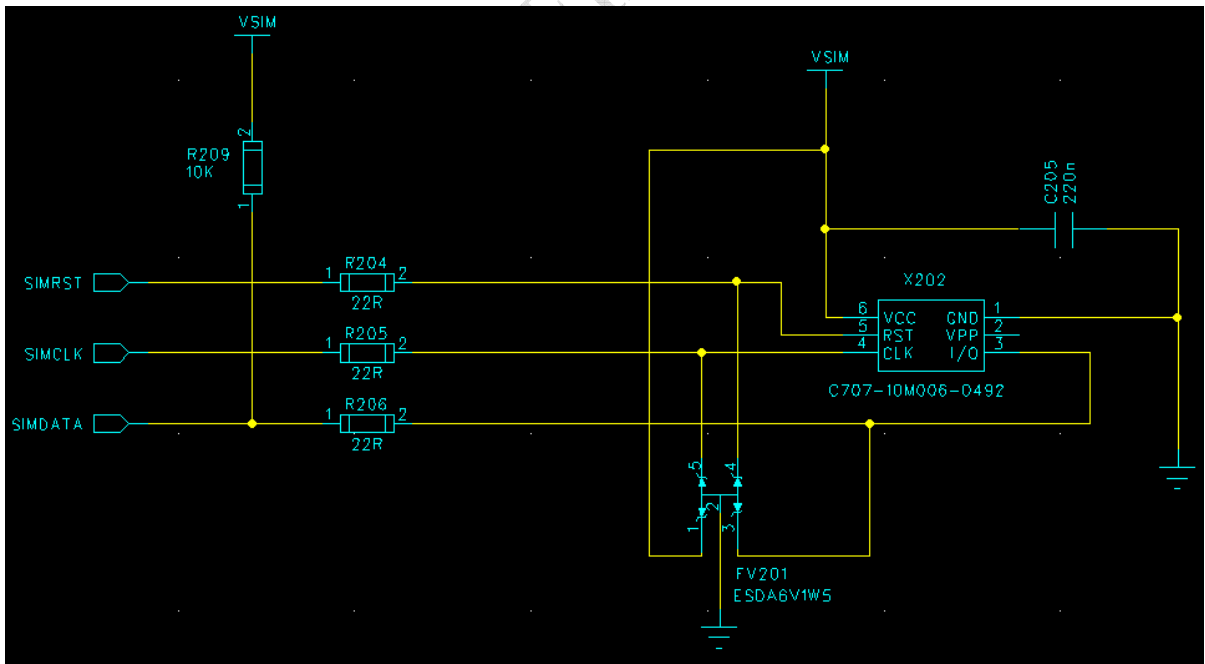

Figure 4: Reference circuit of 6PIN SIM card

7. Audio circuit

The peripheral microphone power supply circuit used in the SIM100S peripheral circuit can be deleted in SIM300. Because it has put internal to SIM300 for reduce the custom's BOM, you can connect the microphone directly to the MIC pin by differential mode or single-ended mode. The reference circuit is showed as the following figure.

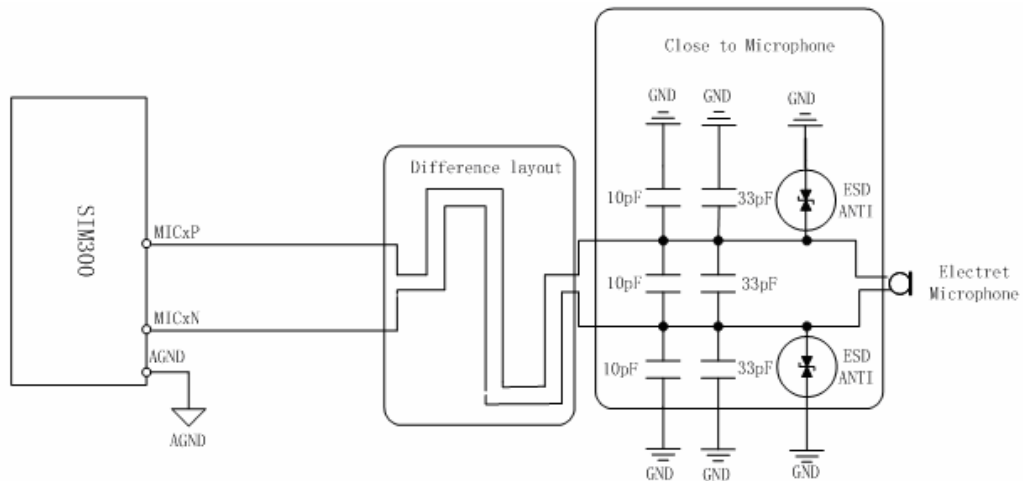

Figure 5: Microphone circuit

The Speaker circuit of SIM300 is as same as SIM100S, but we recommend customer add the ESD device to protect the voice signal to SPEAKER interface from human body electrostatic, showed as the following figure.

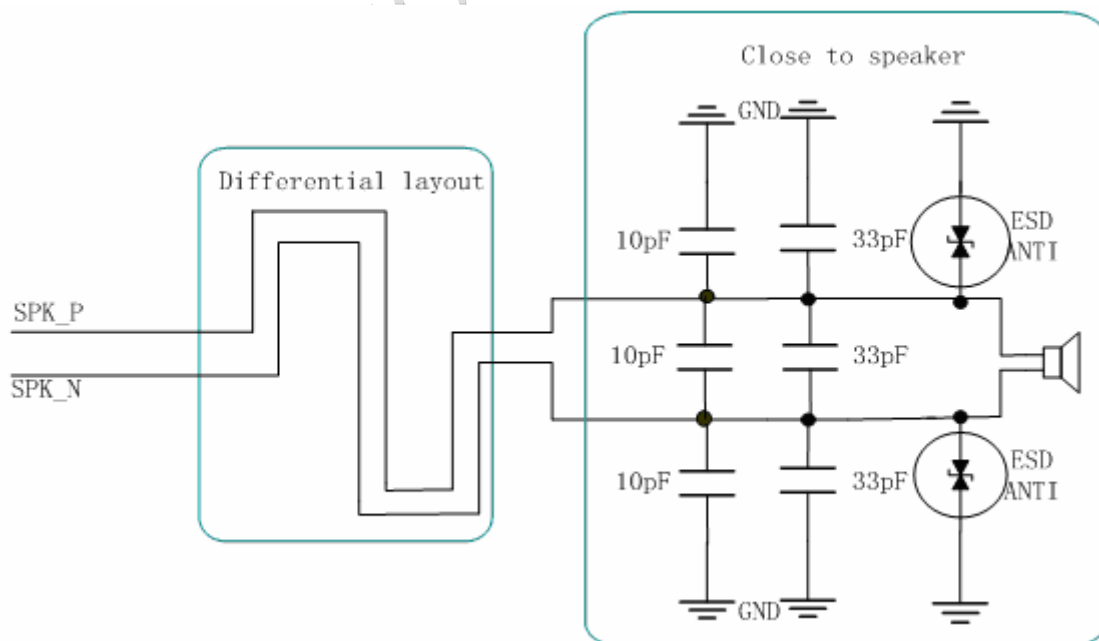

Figure 6: Speaker circuit

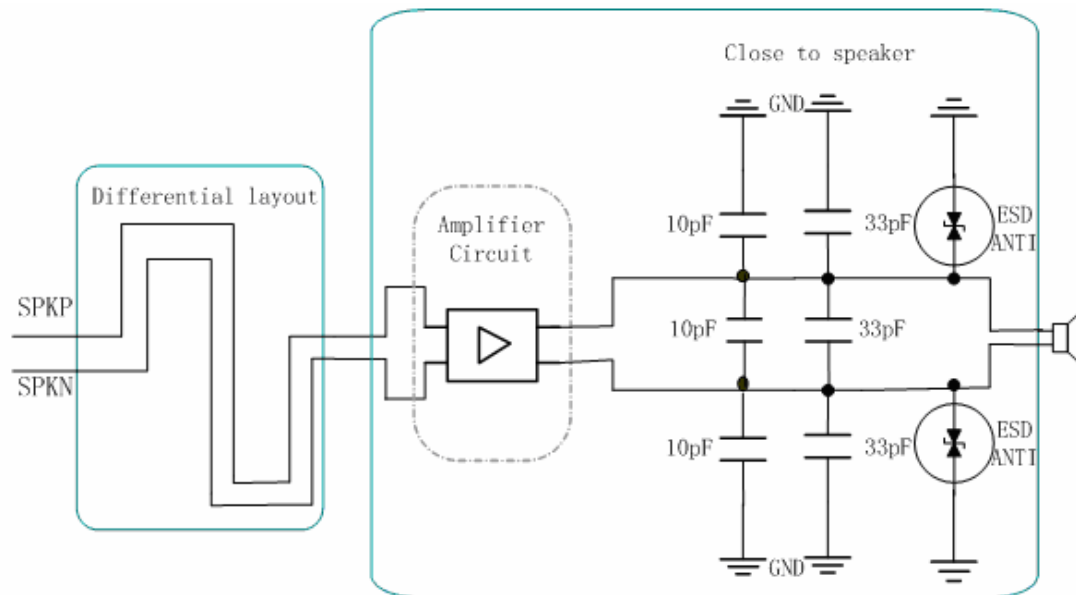

Figure 7: Speaker circuit about amplifier

8. Power supply and the others

The PIN17 of the SIM300 is power supply output pin VEXT. It is **3.0±0.15V/60mA**. The user can use it to drive the other peripheral system if it is needed.

The others, the size of SIM300 is **40 x 33 x 2.85mm**, smaller than SIM100S. The height of BTB is **2.0mm**. The connector ENTERY 1009-G60N-01R or MOLEX-52974-0608 is used in socket side (SIM300 module) and ENTERY 1008-G60N-01R or MOLEX-53729-0608 is used in pin side (user side). Please use it in couples.

Expect for the above content, the SIM300 is same as the SIM100S; including the peripheral circuit, PCB layout and the audio trace layout, etc.