

[查询MP227A供应商](#)

[捷多邦, 专业PCB打样工厂, 24小时加](#)

[急出货](#)

### Description

The Analogic **MP227A** is a precision isolation amplifier that provides an unparalleled combination of linearity, stability, isolation, and very low cost. It is designed primarily to replace relays and filter elements in multichannel data acquisition systems. However, its unique features make it attractive wherever low-level, low frequency signals must be amplified in the presence of severe common mode interference.

The **MP227A** offers user-selectable gains from 10 to 1000, input full-scale voltage ranges from  $\pm 10$  mV to  $\pm 1$  V, 3-pole (60 dB/decade) filtering from 5 Hz, extremely good linearity, superb common-mode rejection, and very low drift. All parameters are commensurate with A/D conversion at levels up to 13 bits.

The **MP227A** includes an internal power oscillator and isolated supply so that no external drivers are needed. The isolated power ( $\pm 4$  V nominal) can be used for open thermocouple indication or offsetting strain gauge inputs.

### Features

- **High Common Mode Rejection**  
170 dB
- **Excellent Linearity**  
0.0075%
- **Selectable Input Range**  
 $\pm 10$  mV FS to  $\pm 1$  V FS
- **Low Noise**  
 $< 0.5 \mu\text{V rms}$
- **Low Drift**  
 $3.0 \mu\text{V RTI}$  per month
- **Built-in 3-pole Filtering**
- **Built-in Oscillator/Driver**

### Applications

- **Thermocouple Temperature Measurement**
- **Weighing Systems**
- **Strain Gauge Measurements**
- **Remote Data Acquisition and Precision Telemetry Systems**
- **Microvolt and Millivolt Level Measurements**
- **Replacement for Classical Instrumentation Amplifier**

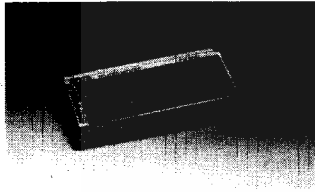

**ANALOGIC**

## MP227A

Isolation Amplifier

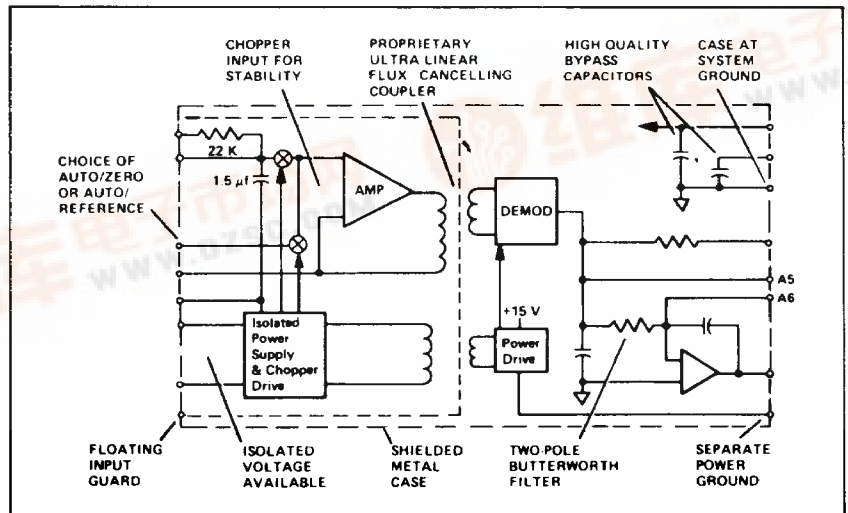

Figure 1. MP227A Block Diagram.

## SPECIFICATIONS

(All specifications guaranteed at 25°C unless otherwise noted)

### ANALOG INPUT

#### Gain Range

10 to 1000, non-inverting, resistor programmable; optimized for gains of 50 to 500

#### Non-linearity

± 0.0075% FSR maximum at G = 50 to 500;  
± 0.01% FSR maximum at G = 1000;  
± 0.05% FSR maximum at G = 10

#### Input Amplifier Type

Isolated Chopper

#### Linear Differential Input Voltage Range

± 10 mV to ± 1V full scale

#### Maximum Safe Differential Input Voltage

16V rms continuous, without damage

#### Common Mode Isolation Voltage

1000 Vdc, 750V rms, maximum

#### Common Mode Rejection Ratio

At dc, with G = 100 and 1000, 166 dB minimum;  
1 k $\Omega$  source unbalance

At 60 Hz, with G = 100 and 1000, 176 dB typical,  
160 dB minimum; 1 k $\Omega$  source unbalance

#### Common Mode Impedance

10,000 M $\Omega$  // 80 pF

#### Differential Input Impedance

At dc, 12 M $\Omega$ ; at ac, low-pass filter of 22 k $\Omega$  and  
1.5  $\mu$ F

#### Overload Input Impedance

22 k $\Omega$ , at 50/60 Hz

#### Input Bias Current

0.5 nA typical, 3.0 nA maximum; bias current increases if open input indicator circuit is used

#### Offset Voltage

At G = 10, ± 1 mV typical, ± 5 mV maximum; at  
G = 1000, ± 150  $\mu$ V maximum; all referred to input (RTI); offset voltage may be determined by interpolation for other gain values

#### Voltage Noise (0.01 to 5 Hz)

At G = 10, 1.5  $\mu$ V rms maximum; at G = 100 and  
1000, 0.5  $\mu$ V rms maximum; RTI

#### Bandwidth (See Note 1)

dc to 5 Hz nominal; 6 dB down at 5 Hz

#### Overall Filtering (See Note 2)

3-pole, 60 dB/decade roll-off (– 60 dB at 50 Hz)

#### Input Filter

1-pole RC, 3 dB cut-off at 5 Hz

#### Output Filter

2-pole Butterworth, 3 dB cut-off at 5 Hz

### ANALOG OUTPUT

#### Voltage Range

± 10V full scale

#### Output Impedance at dc

0.1 $\Omega$

#### Maximum Load

### Output Protection

Continuous short circuit to ground

### Output Chopper Noise (1 MHz BW)

± 1 mV p-p spike at approximately 10 kHz (See Note 3)

### STABILITY

#### Gain Tempco

At G = 10 and 100, ± 25 ppm FSR/°C maximum;  
at G = 1000, ± 35 ppm FSR/°C maximum; exclusive of external gain setting resistor

#### Offset Voltage Tempco

At G = 10, ± 5.0  $\mu$ V/°C maximum;  
At G = 100, ± 1.7  $\mu$ V/°C maximum;  
At G = 1000, ± 0.5  $\mu$ V/°C maximum;  
all RTI

#### Bias Current Tempco

100 pA/°C maximum, at 25°C; doubles every  
10°C (maximum)

#### Power Supply Sensitivity

At G = 1000, ± 2.0  $\mu$ V/%; at G = 10, ± 10  $\mu$ V/% maximum; RTI

#### Warm up Drift (5 Minutes)

Within 2  $\mu$ V RTI typical at G = 1000

#### Long Term Drift

3.0  $\mu$ V RTI/month typical

### ISOLATED POWER SUPPLY OUTPUT

#### Voltage

± 4 Vdc nominal, with respect to INPUT LO

#### Current

± 3 mA full load

#### Regulation

12%, no load to full load

#### Ripple

60 mV p-p at 10 kHz

### INPUT POWER SUPPLY REQUIREMENTS

+ 15V, ± 3%

3 mA, no load

– 15V, ± 3%

5 mA, no load

### ENVIRONMENTAL AND MECHANICAL

#### Operating Temperature Range

0°C to + 70°C

#### Storage Temperature Range

– 55°C to + 85°C

#### Relative Humidity

0 to 85%, non-condensing up to 40°C

#### Dimensions

1.2" x 2.8" x 0.5" (30 x 70 x 12 mm)

#### Shielding

RFI: 6 sides; EMI: 5 sides



#### NOTES:

1. Modifications for bandwidths from dc to 100 Hz, or optimized for specific settling times are available on special order. Please contact factory.
2. Filter nodes are externally accessible to allow modification of characteristics.
3. Output Chopper noise can be reduced to negligible level by suggested output multiplexer circuit.

## OPERATION DATA

### Application

The **MP227A** was designed as an economical, competitive and functionally superior alternative to the relay multiplexing circuits traditionally used in multichannel data acquisition systems. In a typical thermocouple system, the **MP227A** replaces two functional blocks for each channel — the input filter and a dual relay, as well as the common channel high gain amplifier — and permits high-level, solid-state multiplexing to be used for low cost and high reliability.

The **MP227A** provides significantly better isolation and common-mode rejection than low-level relays and it puts the gain at a point in the system where the bandwidth is lowest (prior to multiplexing), thereby reducing total system noise. Even where multiplexing is not used, the unusual combination of performance and price makes the **MP227A** attractive for a wide variety of industrial applications.

When many **MP227A**'s are used in a system, a high speed, high level analog multiplexer switches the **MP227A** outputs to a common analog output bus for subsequent A/D conversion. Any high precision isolation amplifier/filter used in such a configuration has an inherent error source of sizable magnitude that is often overlooked, ignored or simply unknown, that is, dumped charge effects. This Application Note discusses the problem, the solution, and the fringe benefits.

### Dumped Charge

Figure 2 shows the apparently straightforward connection of multiple amplifiers/filters and multiplexer to a common A/D converter.

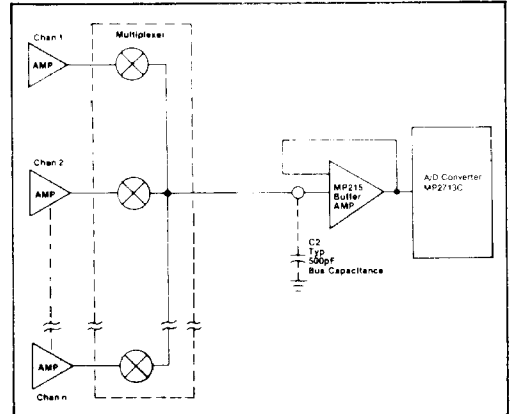

**Figure 2. Multiplexing Amplifier Outputs.**

Each time the multiplexer in Figure 2 switches channels, for instance, from Channel 1 to Channel 2, the Channel 1 output appears across C2, the capacitance of the output bus. The output stage of Channel 2 must absorb that dumped charge before it can reach a true final value dependent only on its input. The exact magnitude of the dumped charge is not important: what is significant is that the Channel 2 amplifier may be forced to deliver a peak instantaneous current beyond its design specifications.

The dumped charge (Q) is defined as,  
 $Q = idt$ ,

where  $i = C dv/dt$

In a typical example, the outputs of the two channels could be at the extreme ends of the range.

Channel 1 output = +10V.

Channel 2 output = -10V.

This makes the voltage difference (dv).

$dv = 20$  volts.

Assume that the capacitance of the output bus C2 is about 500 pF, and a reasonable turn-on time for an analog switch is 100 ns, or,

$C = 500 (10^{12})$

$dt = 100 (10^9)$

Solving first for the current and then the dumped charge, gives:

$$i = C (dv/dt) = \frac{500 (10^{12})}{100 (10^9)} 20 = 100 \text{ mA}$$

$$Q = idt = (100)(10^3)(100)(10^9) = 10,000 \text{ pico Coulomb}$$

Under these conditions, IC op amps, such as the popular 741, have been found to have full-scale current excursion lasting as long as a microsecond.

If the design factors allow a conventional IC output stage to drive the multiplexer instead of a high precision amplifier with an output/filter stage, no real harm is done by the dumped charge. The amplifier eventually recovers and C2 charges to the new value. The recovery time constant is the ON resistance of the multiplexer switch and C2 for  $R_{on} = 300\Omega$

$$C2 = 500 \text{ pF}$$

$$T = (300)(500) 10^{-12} = 0.15 \mu\text{s}$$

In high resolution systems, 10 time constants should be allowed to reach a voltage within 0.005% of final value. Therefore, the actual time should be  $1.5 \mu\text{s}$ .

The  $1.5 \mu\text{s}$  settling time required in this example is usually less than the settling time of the conventional buffer amplifier at the multiplexer output and the dumped charge effect can be safely ignored. The dumped charge cannot be safely ignored, however, when high precision amplifiers employing output filters are required.

### The Problem

Many isolation and/or instrumentation

amplifiers do not include an output filter. On the other hand, the **MP227A** has an integral two-pole Butterworth filter in the output stage. The feedback element of the **MP227A** is a capacitor and a sudden voltage step at the amplifier output, such as the dumped charge, presents a problem.

The dumped charge demands excessive current in too short a time and causes the amplifier to momentarily open-loop. The summing node changes to a large voltage, inducing current flow in the input resistor and causing an extraneous charge on the feedback capacitor.

This error source has produced observed errors as large as 0.05% in typical applications.

### The Solution

Figure 4 shows the addition of a single-pole filter (R1, C1) at the output of each **MP227A** and ahead of the multiplexer. C1 of the succeeding channel, now absorbs the charge accumulated on C2 from the preceding channel. The **MP227A** no longer sees a step but a well controlled exponential change, well within its capabilities. Hence, the output stage in the **MP227A** does not open-loop, and no spurious charge is placed on the feedback capacitor.

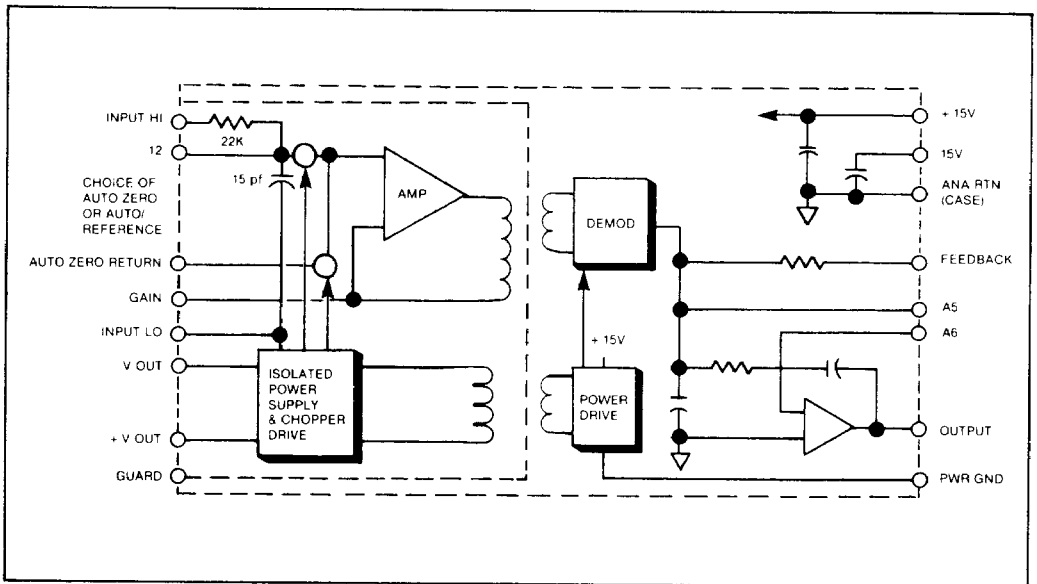

**'A Isolation Amplifier Functional Block Diagram.**

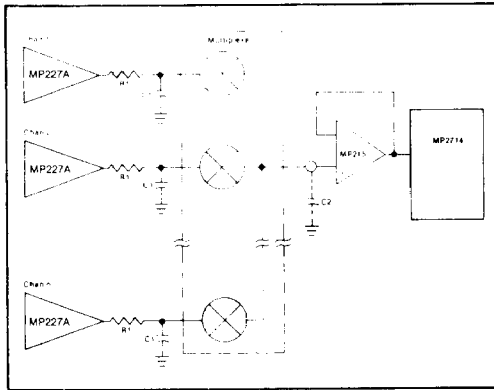

Figure 4. MP227A with Output Filters Added.

The best results are obtained with a time constant between 0.25 and 0.5  $\mu$ s. This must be short for two reasons: 1) a settling time of up to 10RC does not significantly add to multiplexer settling time and 2) the recovery time is sufficiently short for final values that are independent of the duty cycle involved in reading a channel.

R1 should be between 50 and 270 $\Omega$ : this value is kept intentionally low to reduce voltage divider error ( $R1 + R_{on}$  relative to  $R_{in}$  of the follower at the multiplexer output) to an insignificant level. These values of R1 yield values for C1 between 10,000 pF and 1,000 pF which is an acceptable range for C1. In the capacitive voltage divider, formed by C1 and the bus capacitance C2, as C1 decreases in size relative to C2, the initial voltage transferred to C1 by a succeeding channel approaches its final value and leaves a smaller exponential rise portion.

R1, C1 MUST BE INCLUDED FOR ALL HIGH RESOLUTION (>12 BITS) APPLICATIONS OF THE MP227A.

### Fringe Benefits

Noise spikes inherent in the design of high performance isolation amplifiers are attenuated by 10 dB or more by the R1 C1 output filter.

The superior isolation of the MP227A is provided by transformer coupling. A modulator/demodulator is used in the analog signal path and is driven by an integral chopper/power driver. It is impossible to avoid some stray capacitance between the driver circuitry and the output. Careful design and layout of the MP227A has reduced input noise spikes caused

by stray capacitance to 1 mVp-p, which is 0.01% relative to 10V F.S., when measured over a bandwidth of 1 MHz. The noise spikes repeat at 20 kHz, or twice the nominal 10 kHz frequency of the MP227A chopper driver.

If the output filter time constant ( $R1 C1$ ) is equal to 0.5  $\mu$ s, then

$$f_c = \frac{1}{2\pi RC} \\ = 333 \text{ kHz}$$

This low cut-off frequency ensures that the output spikes, over an effective bandwidth in excess of 1 MHz, are attenuated 10 dB or more, which is enough to reduce this error source from .01% to a negligible level.

## USING THE MP277A

### Offset Adjustment

Provision is made for external offset adjustment on the MP227A Precision Isolation Amplifier by connecting a 25k or 50 k $\Omega$  (100 ppm/ $^{\circ}$ C or better) multi-turn potentiometer (R2) with a 1 M $\Omega$  resistor as shown in Figure 2. To adjust, momentarily short INPUT HI, INPUT LO, and AZ RTN to the output ANA RTN and set the offset potentiometer for zero output at the OUTPUT terminal.

### Setting the MP227A Gain

The gain of the MP227A may be set to any value from 10 to 1000 by connecting an external resistor ( $R_G$ ) between the GAIN and INPUT LO terminals as shown in Figure 5. Gain is equal to:

$$\text{Gain} = \frac{10.375 \times 10^3}{R_G \Omega}$$

An RN55E or better resistor is recommended for temperature stability. Untrimmed, the absolute gain will be within +2% and -3% of the calculated value.

### Gain Trimming

The gain may be deliberately fine-trimmed, if desired, by connecting a 500 $\Omega$  (100 ppm/ $^{\circ}$ C or better) potentiometer (R1) between the FEED-BACK and OUTPUT terminals as shown in Figure 2. R1 compensates for the tolerance of  $R_G$  plus the unit-to-unit gain variability (3%) between multiple MP227As. This also allows standardization of the outputs of multiple MP227As to a common full-scale range. For volume production where cost is a factor, the trimpot may be replaced with a fixed resistor

## Auto-Zero Return

The signal that is amplified by the **MP227A** is actually the difference between the **INPUT LO** and the Auto-Zero (**AZ**) voltages. For normal operation, tie the **AZ** terminal directly to the **INPUT LO** terminal. In some applications, it may be convenient to offset the input deliberately by an amount that exceeds the range of the **OFFSET** trimpot (for example, to obtain expanded scale operation or to cancel out the initial or "tare" output of a load cell). To do this, connect the **AZ** terminal to a source of voltage equal to the desired offset, with noise performance and stability at least as good as the signal source.

Observe that both the **INPUT HI** signal and the **AZ** signal (if any) are measured with respect to the **INPUT LO** terminal. For best linearity, each signal must be within  $\pm 1V$  of **INPUT LO**.

## Open Input Indication

The user-accessible isolated power supply voltages make it possible to use a simple open input indication network. Connect a resistor on the order of  $180\text{ M}\Omega$  to the **INPUT HI** and either the  $+4V$  or  $-4V$  isolated power output terminal. This network produces a bleeder current of approximately  $20\text{ nA}$  through the input source circuitry. If the source should open, this bleeder current will drive the **MP227A** output into a saturated state. The speed of this response is a function of the **MP227A** gain setting and input time constant.

## Multiplexing MP227As

The outputs of multiple **MP227As** may be multiplexed to a common analog line as indicated in Figure 4. A single RC filter ahead of each MUX input is suggested.

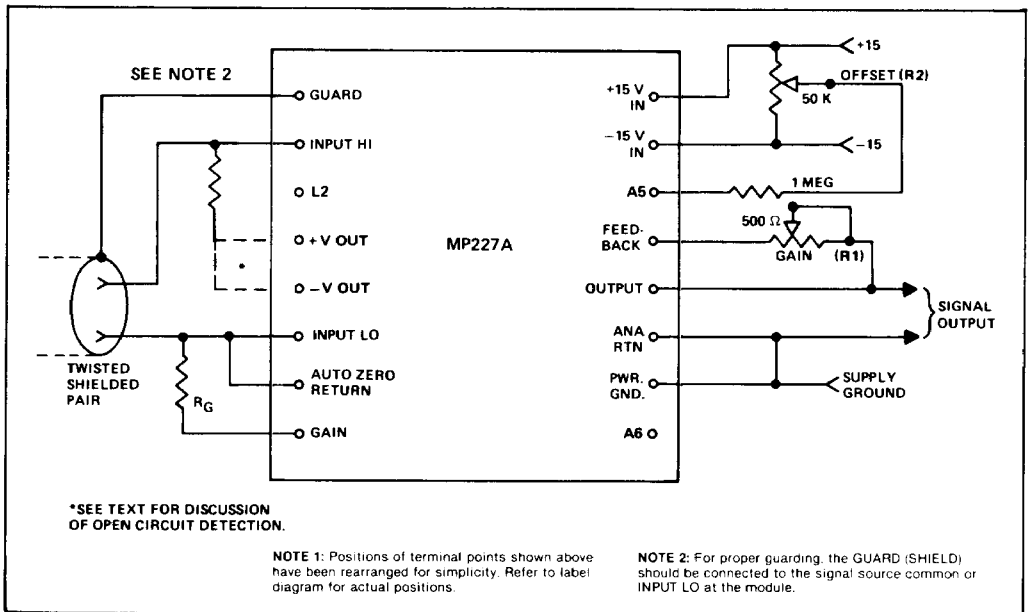
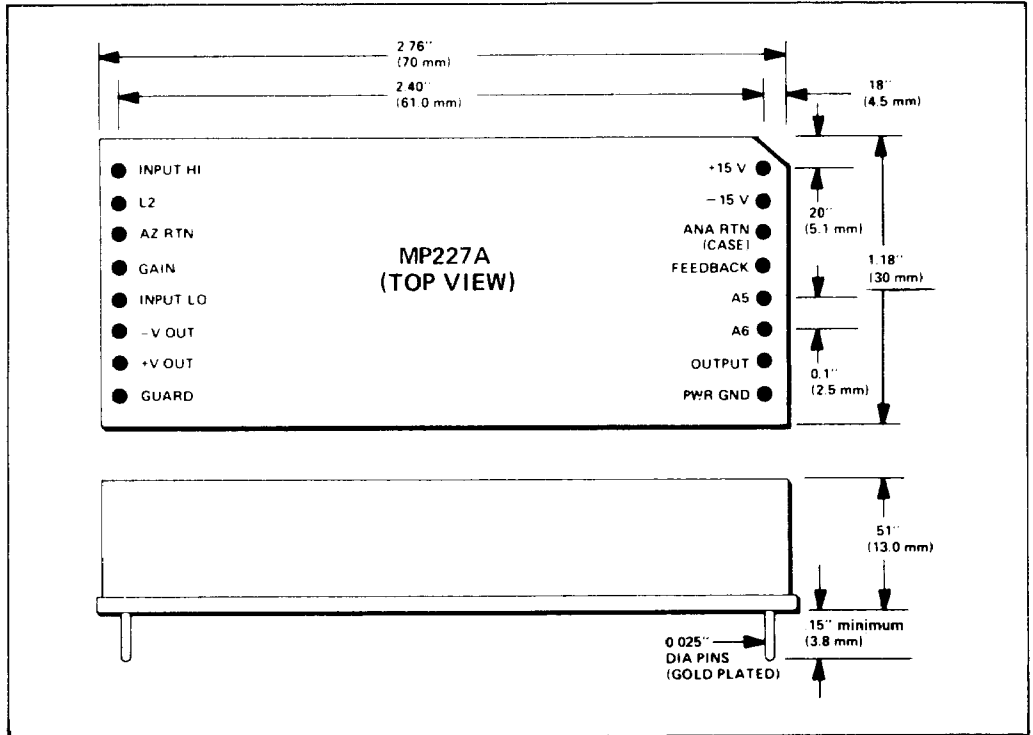

Figure 5. Typical External Connections—MP227A.



AMPLIFIERS

Figure 6. MP227A Mechanical & Pinout.

## ORDERING GUIDE

Specify MP227A

