

AuthenTec EntréPad 3400



World's Smallest Secure Touch Sensor for the PC Market

The EntréPad 3400 provides advanced security in the world's smallest, lowest cost, and most proven touch sensor for the PC market.

Widely used in a variety of notebooks, desktops and PC peripherals, the EntréPad 3400 features an integrated Universal Serial Bus, and fully supports advanced USB power states -- including selective suspend -- extending critical battery life on mobile devices.

The EntréPad 3400 includes AuthenTec's unique Power of Touch, enabling PC manufacturers to easily and cost-effectively add other convenience, navigation and personalization functions that are controlled by the simple touch of your finger. With the Power of Touch, the same sensor allows manufacturers to add features that differentiate the PC and improve the user experience.

KEY FEATURES AND BENEFITS

SUPERIOR TECHNOLOGY

- TruePrint technology provides the most accurate fingerprint image
- TrueMatch pattern matching technology runs on high-performing host processor

TRUSTED SECURITY

- Pattern matching delivers industry best false accept/false reject (FAR/FRR) performance
- Digitally signed images
- Challenge response protocol between sensor and software
- 256-bit AES encrypted fingerprint templates

USER UPGRADEABLE

- Secure HDD storage and matching algorithms and templates -- not ROM
- Users can easily upgrade matcher to latest version
- Protects users from future sensor attacks

EASY TO USE

- Able to read virtually every fingerprint
- Pattern matching technology delivers the industry's best enroll, verify and reject performance (false accept/false reject)
- BIOS features single touch to the desktop

LOW POWER

- USB low power device supports selected suspend, extending battery life

DURABILITY

- Ultra hard surface coating withstands greater than 1 million touches

ROBUST APPLICATION SOFTWARE FEATURE SET

- Supports multi-factor authentication -- combining the sensor with smartcards, TPMs, etc.
- Login and password replacement
- File/folder encryption, secure email, password replacement, and secure file sharing

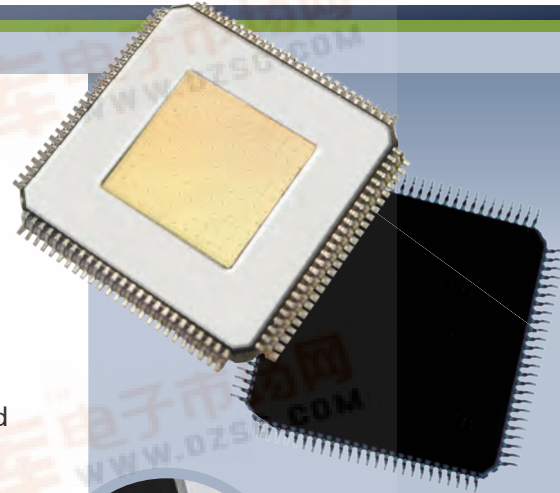

LAPTOPS



DESKTOPS



MICE



PC CARDS

THE POWER OF TOUCH

Enables unique touch powered features
Quick application launch, fast user switching, and more

The Power of Touch

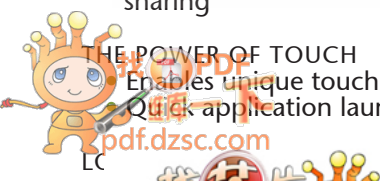

AuthenTec EntréPad 3400

THE AUTHENTEC DIFFERENCE

SUPERIOR TRUEPRINT AND TRUEMATCH TECHNOLOGIES

The EntréPad 3400 employs AuthenTec's award winning TruePrint® and TrueMatch technologies, the most accurate sensor and pattern matching technologies in the industry. These combined technologies capture the highest quality fingerprint images – resulting in significantly better performance than any other solution on the market today.

THE POWER OF TOUCH

AuthenTec's unique Power of Touch approach combines the most advanced security, with additional convenience, navigation and personalization functions controlled by the simple touch of your finger. The Power of Touch enables PC manufacturers to easily and cost-effectively add capabilities such as data protection, password replacement, finger-control scrolling, quick applications access, fast user switching and other functions.

EntréPad 3400 SPECIFICATIONS

High Performance Features	Advanced security Integrated USB interface
Small Form Factor	100-pin LQFP package 14mm x 14mm x 1.55mm
Robust Packaging	Scratch and impact resistant Ultra hard surface coating withstands greater than 1 million touches
	RoHS compliant / Lead Free
Detection Matrix	128 x 128 pixels @ 500 ppi 6.5mm x 6.5mm array size
SelectaBus	USB 1.1/2.0 full speed USB low power device Supports C3 selective suspend mode
	8-bit parallel interface Asynchronous serial interface Synchronous serial interface
Operating Voltage Range	2.7V-3.6V
Commercial Temperature Range	-20C to +70C
Current Consumption @ 3.3V	Low power USB device 500 µW finger detection 60 µW standby
	Advanced finger detection
ESD Resistance	IEC 61000-4-2 Level 3 (+/- 8KV)
Supported Operating Systems	Microsoft Windows Vista and XP Linux

EntréPad 3400 INTEGRATED FINGERPRINT MODULE

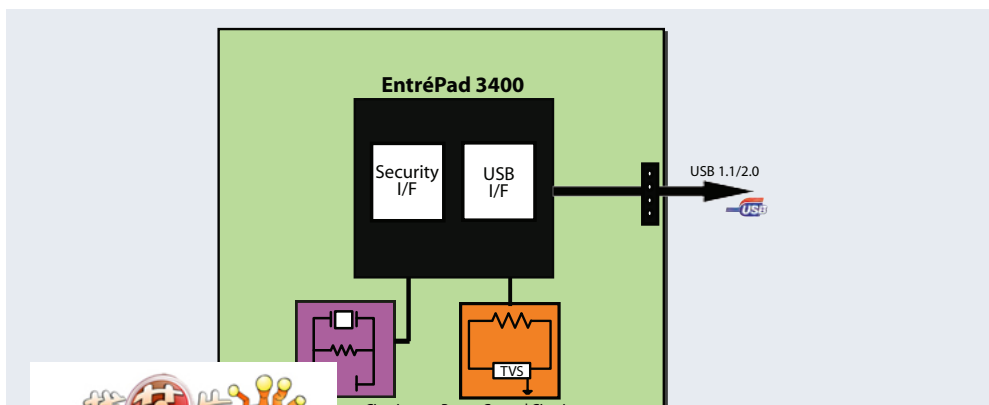

THE AUTHENTEC TOTAL SOLUTION

AuthenTec offers the most complete and flexible solution to enable manufacturers to design in advanced biometric fingerprint sensors. Our total solution approach includes a complete family of sensors; hardware and software kits for easy evaluation and integration; proven solutions from more than 50 hardware, software and design partners; and end-to-end integration support from an experienced technical staff.

CONTACT US

NORTH AMERICA

AuthenTec | U.S. Headquarters
709 South Harbor City Blvd.
Melbourne, FL 32901 USA
phone: 321-308-1300

San Jose, CA

phone: 408-879-2383

EUROPE

Germany | Munich

phone: 49 (8444) 918290

ASIA

China | Asia Headquarters
4000 Wen Xiang Road
Songjiang Shanghai 201616
phone: 86-21-5776-3300

Japan | Tokyo

phone: 81-80-5026-9710

Taiwan | Taipei

phone: 886-2-8758 2719

Korea | Seoul

phone: 82-11-380-6164

WORLDWIDE

REPRESENTATIVES NETWORK

A complete listing of AuthenTec's network of representatives is available at our web site.

www.authentec.com

