

USB2.0 PC Camera Controller

SN9C201 Preliminary Specification

Released Version 0.93

November 25, 2004



1. General Description

The SN9C201 is a high speed USB 2.0 compliant video/audio single-chip processor to pair with the resolution of VGA or 1.3M CMOS image sensor. SN9C201 integrates a USB 2.0 controller, high-performance microcontroller, color-processing engine, high-quality image CODEC interface to provide up to 30fps VGA size or 15 fps 1.3 M size video without compression in high speed mode.

2. Features

- 8 or 10 Bit CMOS image raw data input
- Up to 30fps@VGA or 10 ~ 15fps@1.3M for PC mode video
- Provide individual R/G/B digital color gains control
- Provide snapshot function
- Support lens correction and G1G2 filtering
- Support pixel offset compensation
- Support VGA/1.3M CMOS sensor, Hynix 7131R, OmniVision, Pixart 202, Micron 360/1300, Toshiba, ... etc
- Embedded two modes of AE calculation and report
- Built-in external EEPROM controller for customer V_ID, P_ID, defect pixel compensation and streaming setting
- Provide internal up to 26 various P_ID in default setting
- Provide hardware windowing, 1/2, 1/4 scaling function with smooth filter
- Built-in gamma correction and white balance gain circuit
- Support operation mode in image quality/frame rate selection
- USB 1.1/2.0 compliance and support suspend mode
- USB 4 endpoints: control, isochronous read, bulk read and interrupt read
- Support video data transfer either in USB isochronous or bulk modes
- Up to 9 alternated setting for USB isochronous transfer of video data
- 12MHz crystal and 3.3 volt only
- 48 pins LQFP package
- Embedded hardware color DSP and JPEG baseline capability of compression encoder
- No external memory needed
- Support general purpose I/O control

3. Functional Block Diagram

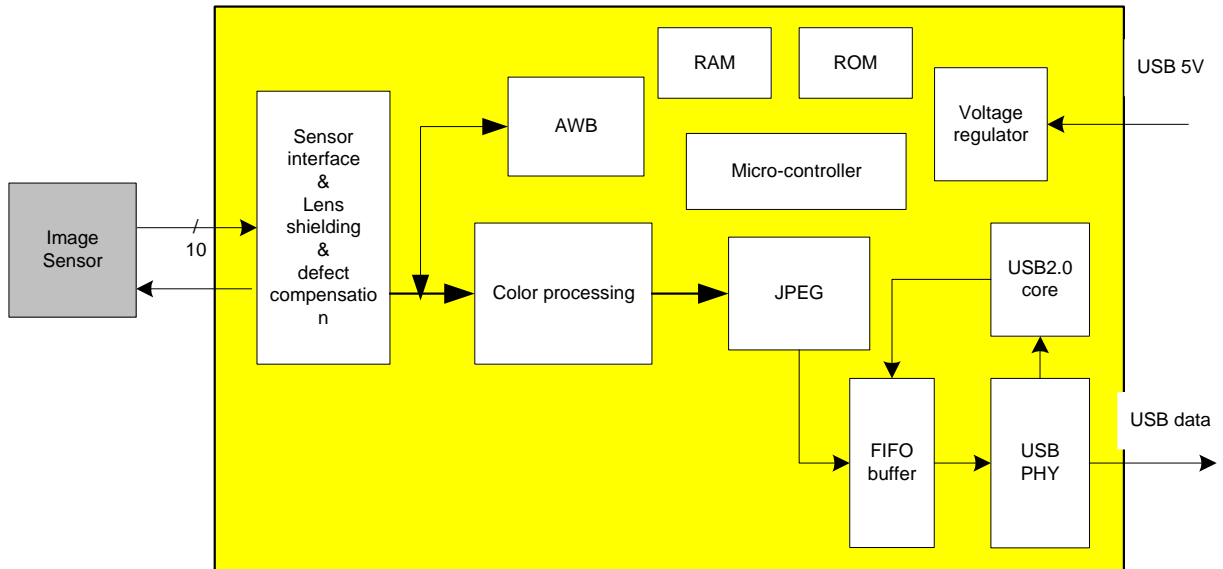

4. Pin Assignment

SN9C201	PIN NAME	DIR	Description
1	VDD	P	VDD 3.3V input for PLL
2	VSS	P	GND for PLL/USB driver
3	DM	B	D- for USB
4	DP	B	D+ for USB
5	VDD	P	VDDA for USB driver
6	VRES	B	Reference for USB driver. (R=2K-3K to GND)
7	VSS	B	GND
8	VDD	P	VDD 3.3V input for Regulator
9	VDDL1	P	Regulator output (1.8V)
10	VSDLC1	P	Regulator Gnd
11	VDD18	P	core VDD 1.8
12	GPIO_8	B	General purpose I/O
13	VSS	P	GND
14	VDD	P	VDD IO 3.3v
15	GPIO_0	B	Product ID selection (H,L,Z)**
16	GPIO_1	B	Product ID selection (H,L,Z)**
17	GPIO_2	B	Product ID selection (H,L,Z)**
18	GPIO_6	B	General purpose I/O

19	SDA	B	SDA for I2C interface (data)
20	SCL	O	SCL for I2C interface (clock)
21	S_PCK	B	Sensor pixel clock
22	SEN_CLK	O	Sensor clock
23	VDD	P	VDD IO 3.3v
24	VSS	P	GND
25	VDD18	P	core VDD 1.8
26	S_VSYNC	B	Sensor vsync
27	S_HSYNC	B	Sensor hsync
28	S_IMG_0	B	Sensor image data
29	S_IMG_1	B	Sensor image data
30	S_IMG_2	B	Sensor image data
31	S_IMG_3	B	Sensor image data
32	S_IMG_4	B	Sensor image data
33	S_IMG_5	B	Sensor image data
34	S_IMG_6	B	Sensor image data
35	S_IMG_7	B	Sensor image data
36	S_IMG_8	B	Sensor image data
37	VDD	P	VDD IO 3.3v
38	VSS	P	GND
39	VDD18	P	core VDD 1.8
40	TEST	I	Test mode
41	GPIO_9	B	General purpose I/O
42	RST	I	Chip reset
43	GPIO_4	I	Snap shot key
44	GPIO_5	I	LED
45	SD_POWER_DOWN	B	Sensor power down
46	GPIO_7	B	General purpose I/O
47	XOUT	B	OSC output (Rf=1M)
48	XIN	I	OSC input (Rf=1M) (12MHz)

5. Electrical Characteristics

5.1 DC Operating Condition

a. Absolute maximum ratings:

Symbol	Parameter	Rating	Units
VDD33	Power Supply	-0.3 to 3.6	V
VDD18	Power Supply	-0.18 to 1.98	
Vin	Input Voltage	-0.3 to Vcc+0.3	V
Vout	Output Voltage	-0.3 to Vcc+0.3	V

Tstg	Storage Temperature	-55 to 150	°C
------	---------------------	------------	----

b. Recommended operating conditions:

Symbol	Parameter	Min	Typ	Max	Units
VDD33	Power Supply	3.0	3.3	3.6	V
VDD18	Power Supply	1.62	1.8	1.98	V
Vin	Input voltage	0		Vcc	V
Topr	Operating Temperature	0		70	°C

c. DC electrical characteristics:

(Under Recommended Operating Conditions and Vcc=3.0 ~ 3.6V, Tj=0 to +115 °C)

Symbol	Parameter	Conditions	Min	Typ	Max	Units
Vil	Input low voltage	CMOS	-0.3		0.3Vcc	V
Vih	Input high voltage	CMOS	0.7Vcc		Vcc+0.3	V
Vil	Input low voltage	TTL	-0.3		0.8	V
Vih	Input high voltage	TTL	2.0		5.3	V
Iil	Input low current	no pull-up or pull-down	-1		1	uA
Iih	Input high current	no pull-up or pull-down	-1		1	uA
Ioz	Tri-state leakage current		-1		1	uA
Vil	Schmitt input low voltage	CMOS		1.20		V
Vih	Schmitt input high voltage	CMOS		2.10		V
Vol	Output Low voltage	Iol=4mA			0.4	V
Voh	Output high voltage	Ioh=4mA	2.4			V
Cin	Input capacitance			2.8		pF
Cout	Output capacitance		2.7		4.9	pF
Cbid	Bi-directional buffer Capacitance		2.7		4.9	pF

5.2 AC Operating Condition

Symbol	Description	Max operation Frequency	Notes
SEN_CLK	Sensor clock	48MHz	
XIN	Crystal input clock	12 MHz	
SCK	I2C clock frequency	400KHz	

6. System Applications

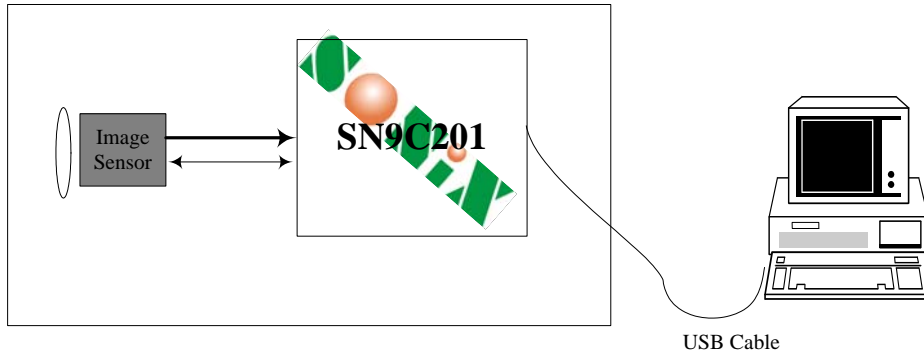

7. Application Circuit

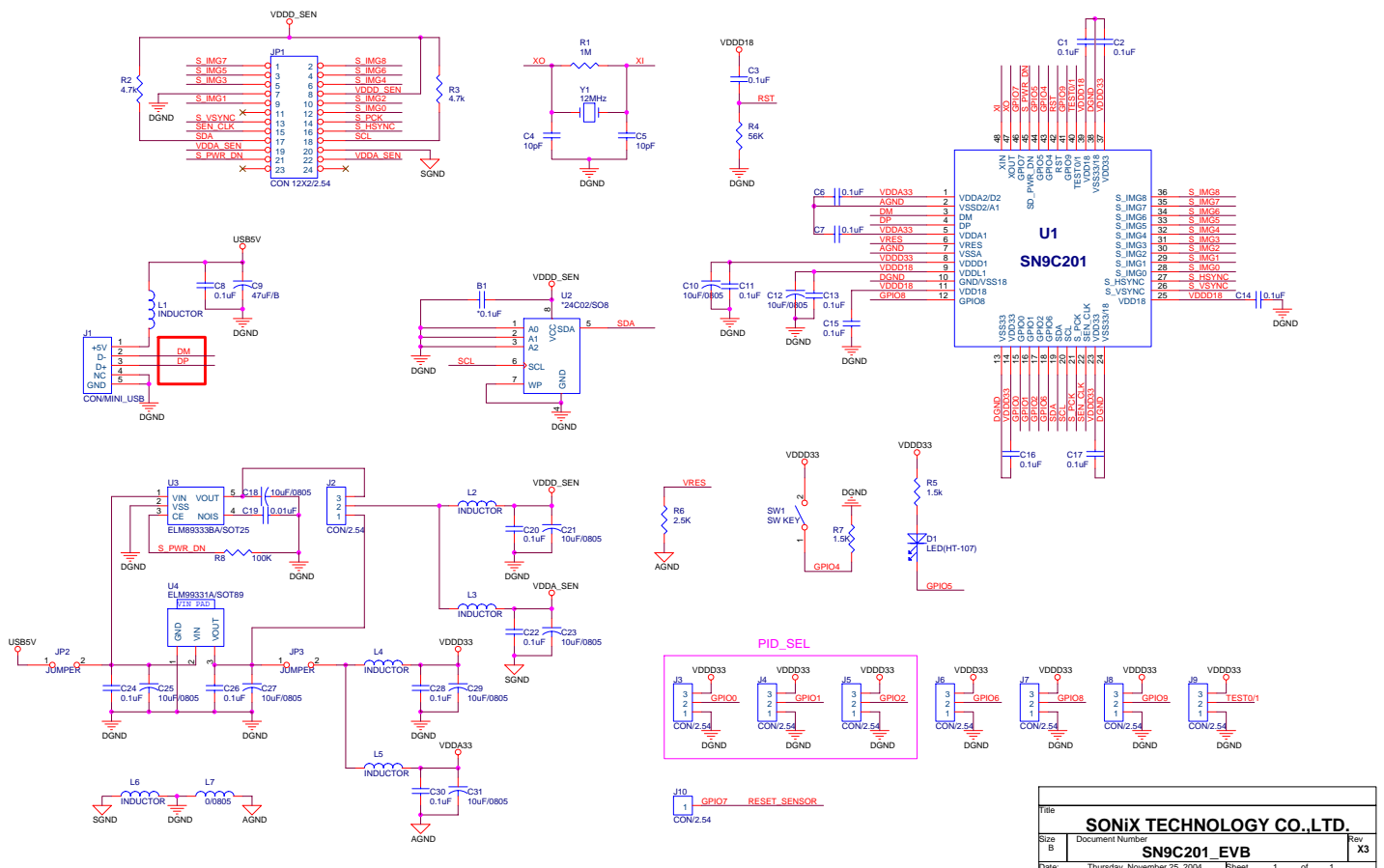

File	SONiX TECHNOLOGY CO.,LTD.		
Size	Document Number	Rev	X3
B	SN9C201_EVB		
Date:	Thursday, November 25, 2004	Sheet	1 of 1

