



PQ1CZ21H2ZxH

PQ1CZ21H2ZxH

Low Dissipation Current at OFF-state
Chopper Regulator

Features

1. Maximum switching current: 1.5A
2. Low dissipation current at OFF-state(I_{qs} :Max.1mA)
3. Built-in oscillation circuit
(Oscillation frequency: TYP.100kHz)
4. Built-in overheat, overcurrent protection functions
5. Variable output voltage
(Output variable range: V_{ref} to 35V/ $-V_{ref}$ to $-30V$)
[Possible to select step-down output/inverting output according to external connection circuit]
6. **PQ1CZ21H2ZZH**: Sleeve-packaged product
PQ1CZ21H2ZPH: Tape-packaged product
7. RoHS directive compliant

Applications

1. Facsimiles
2. Printers
3. Switching power supplies

Absolute Maximum Ratings

($T_a=25^{\circ}C$)

Parameter	Symbol	Rating	Unit
*1 Input voltage	V_{IN}	40	V
Error input voltage	V_{ADJ}	7	V
Input - output voltage	V_{I-O}	41	V
*2 Output - COM voltage	V_{OUT}	-1	V
*3 ON/OFF control voltage	V_C	-0.3 to +40	V
Switching current	I_{SW}	1.5	A
*4 Power dissipation	P_D	8	W
*5 Junction temperature	T_j	150	$^{\circ}C$
Operating temperature	T_{opr}	-40 to +85	$^{\circ}C$
Storage temperature	T_{stg}	-40 to +150	$^{\circ}C$
Soldering temperature	T_{sol}	260(10s)	$^{\circ}C$

- *1 Voltage between V_{IN} terminal and COM terminal
 *2 Voltage between V_{OUT} terminal and COM terminal
 *3 Voltage between ON/OFF control and COM terminal
 *4 P_D :With infinite heat sink
 *5 There is case that over heat protection function operates at the temperature $T_j=125^{\circ}C$ to $150^{\circ}C$, so this item cannot be used in this temperature range.

Outline Dimensions

(Unit:mm)

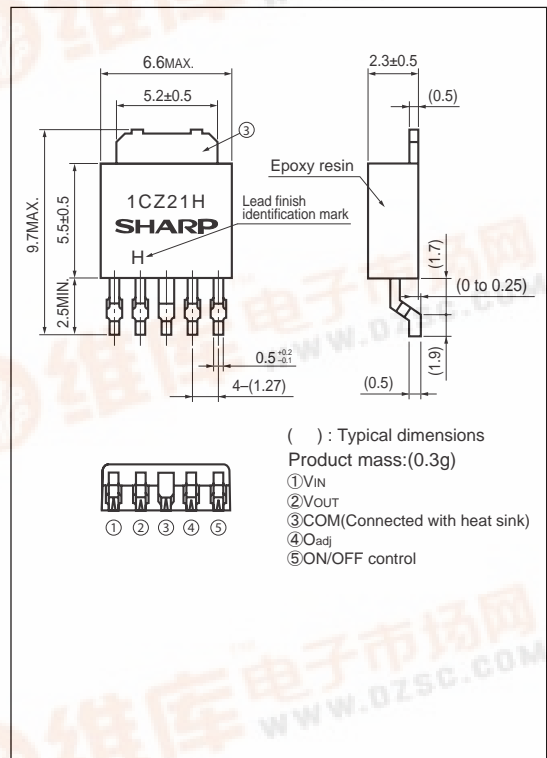

Lead finish:Lead-free solder plating
(Composition: Sn2Cu)



Electrical Characteristics

(Unless otherwise specified, condition shall be $V_{IN}=12V, I_o=0.2A, V_o=5V, ON-OFF$ terminal= $2.7V, T_a=25^\circ C$)

Parameter	Symbol	Conditions	MIN.	TYP.	MAX.	Unit
Output saturation voltage	V_{SAT}	$I_{SW}=1A$	—	0.9	1.5	V
Reference voltage	V_{ref}	—	1.235	1.26	1.285	V
Reference voltage temperature fluctuation	ΔV_{ref}	$T_j=0$ to $125^\circ C$	—	± 0.5	—	%
Load regulation	$ RegL $	$I_o=0.2$ to $1A$	—	0.1	1.5	%
Line regulation	$ RegI $	$V_{IN}=8$ to $35V$	—	0.5	2.5	%
Efficiency	η	$I_o=1A$	—	82	—	%
Oscillation frequency	f_o	—	80	100	120	kHz
Oscillation frequency temperature fluctuation	Δf_o	$T_j=0$ to $125^\circ C$	—	± 3	—	%
Overcurrent detecting level	I_L	Switching current peak	1.55	2	2.6	A
ON threshold voltage	$V_{TH(ON)}$	④ terminal= $0V, ⑤$ terminal	0.8	1.5	2	V
ON-state current for control	$I_{C(ON)}$	⑤ terminal= $2.7V$	—	—	200	μA
OFF-state current for control	$I_{C(OFF)}$	⑤ terminal= $0.4V$	—	—	2	μA
Stand-by current	I_{SD}	$V_{IN}=40V, ⑤$ terminal= $0V$	—	—	1	μA
Output OFF-state dissipation current	I_{QS}	$V_{IN}=40V, ④$ terminal= $3V$	—	8	12	mA

Fig.1 Test Circuit

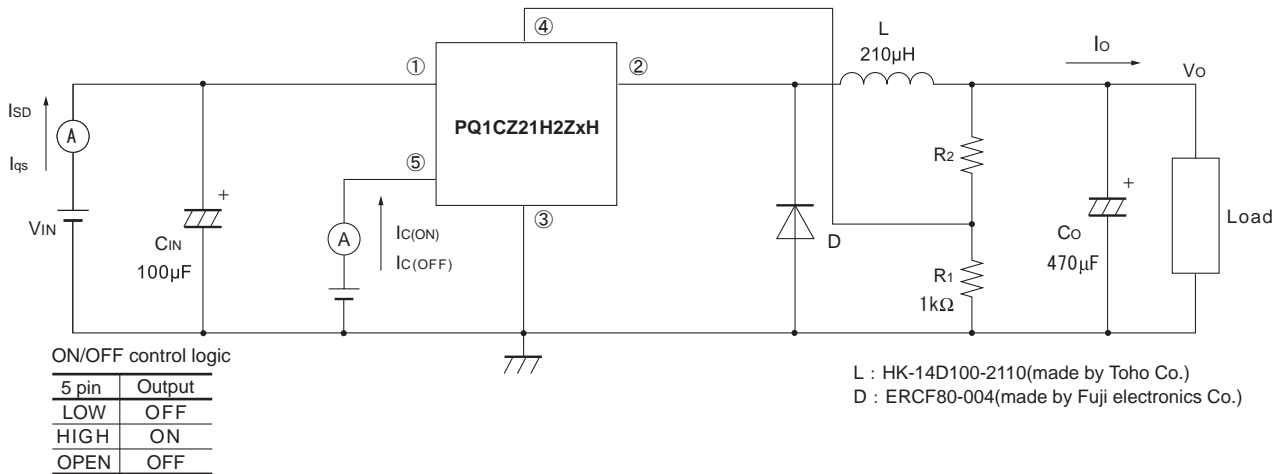
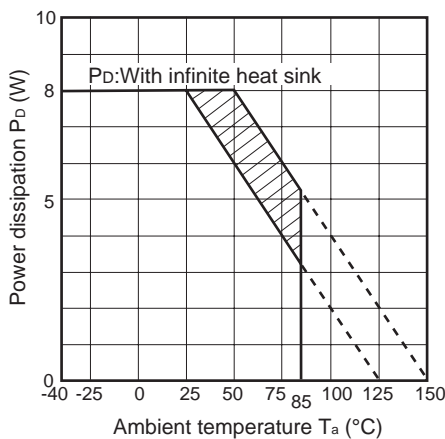

Fig.2 Power Dissipation vs.Ambient Temperature



Note) Oblique line portion:Overheat protection may operate in this area

Fig.3 Overcurrent Protection Characteristics (Typical Value)

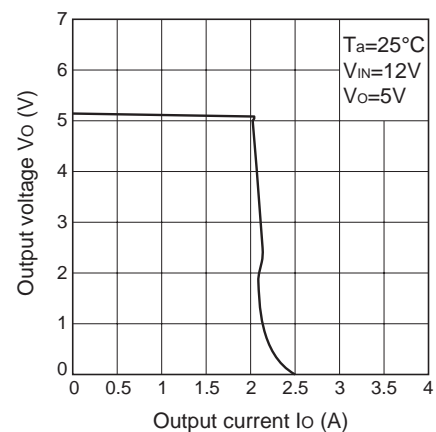

Fig.4 Efficiency vs. Input Voltage

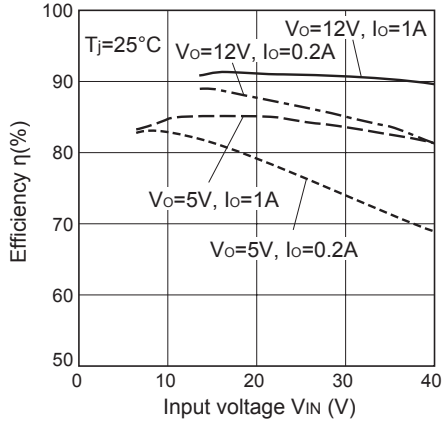

Fig.5 Output Saturation Voltage vs. Switching Current

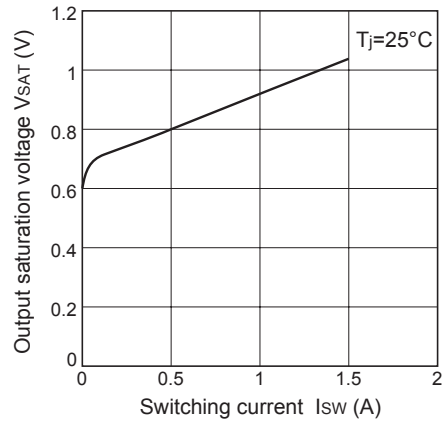

Fig.6 Reference Voltage Fluctuation vs. Junction Temperature

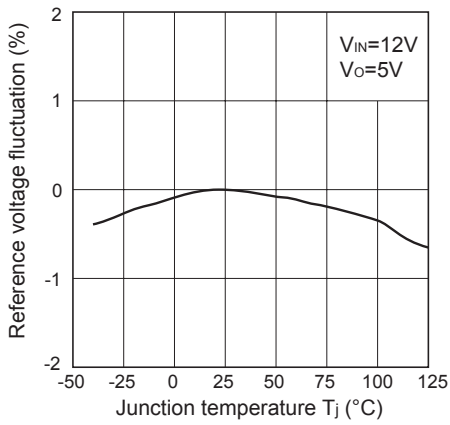

Fig.7 Load Regulation vs. Output Current

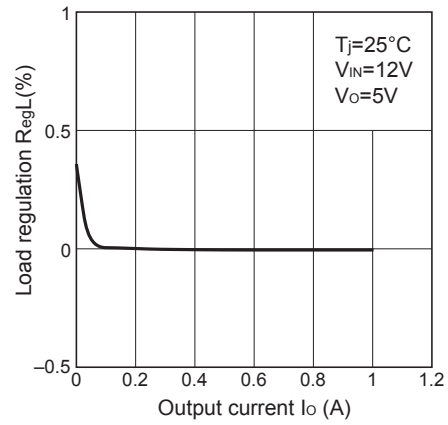

Fig.8 Line Regulation vs. Input Voltage

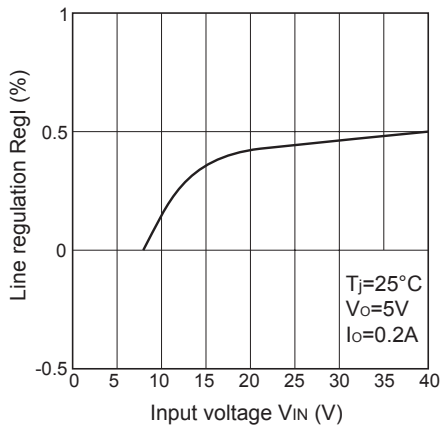

Fig.9 Oscillation Frequency Fluctuation vs. Junction Temperature

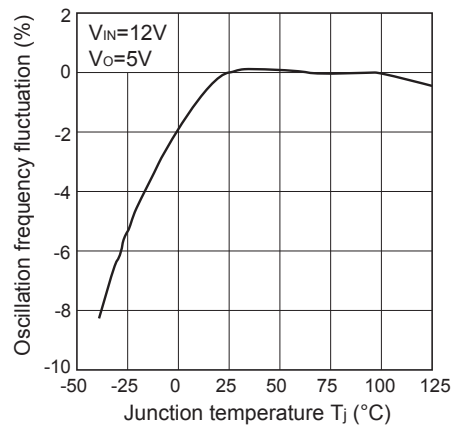

Fig.10 Overcurrent Detecting Level Fluctuation vs. Junction Temperature

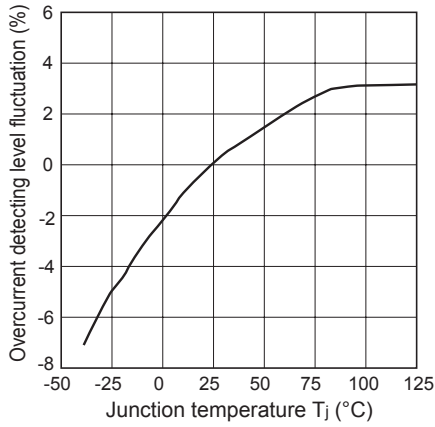

Fig.11 On Threshold Voltage vs. Junction Temperature

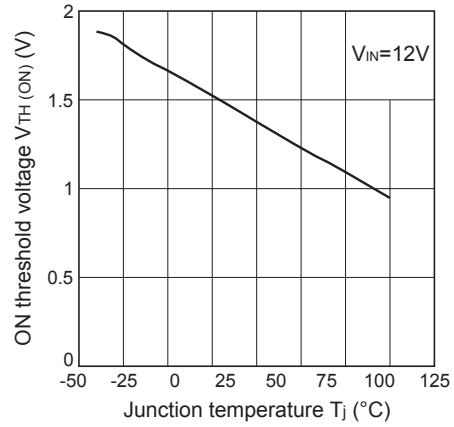

Fig.12 Operating Dissipation Current vs. Input Voltage

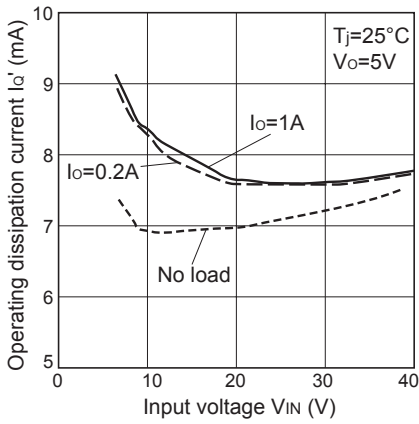
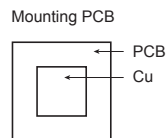
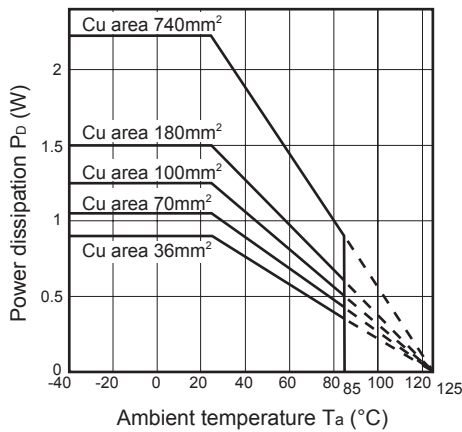

Fig.13 Power Dissipation vs. Ambient Temperature (Typical Value)



Material : Glass-cloth epoxy resin
 Size : 50×50×1.6mm
 Cu thickness : 35μm



Fig.14 Block Diagram

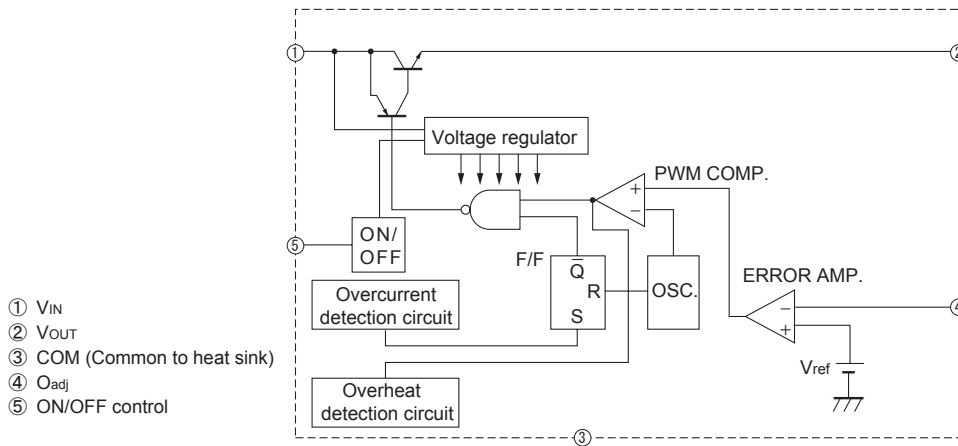

Fig.15 Step Down Type Circuit Diagram

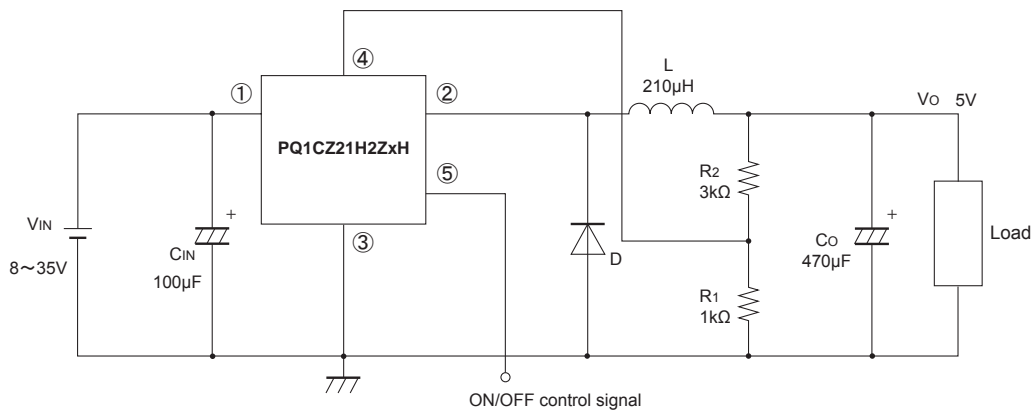
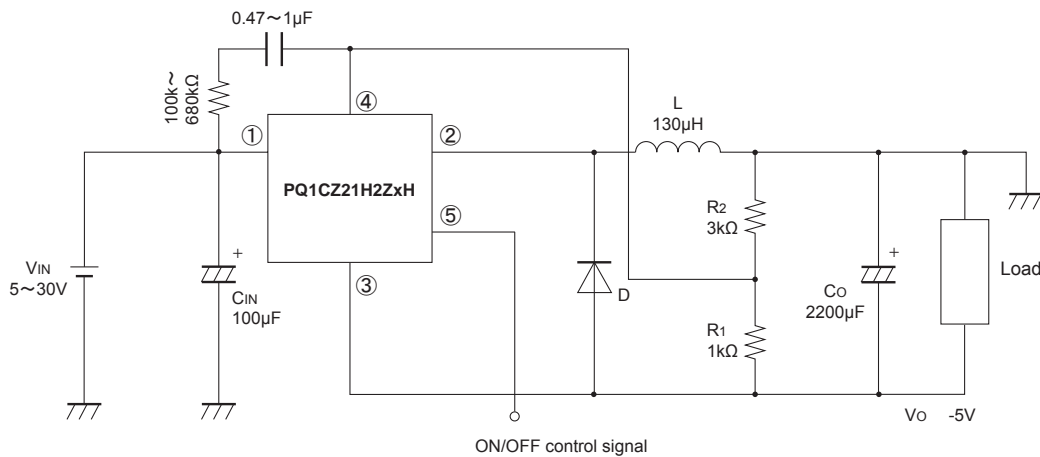

Fig.16 Polarity Inversion Type Circuit Diagram



In case that polarity is reverse, depending on the conditions, there is cases that output voltage can not gain, please use this device after confirming the output voltage at the actual conditions.

