

RF SOLUTIONS

DATA SHEET

TD1300A(L)F mk3

Tuner modules for analog and digital terrestrial (OFDM) applications

Objective specification

Approved by :

Name / Date :

PHILIPS



Tuner modules for analog and digital terrestrial (OFDM) applications

TD1300A(L)F-3

FEATURES



- Highly integrated single conversion tuner with active loopthrough
 - Versions for different frequency ranges available
 - +5V supply voltage only; no external tuning voltage required
 - DC – power output through RF-input connector (e.g. indoor antenna supply)
 - Superior low noise and high sensitivity performance
 - Tuners are suitable for analog and digital applications;
 - Compliant to relevant standards e.g. CENELEC and Nordig
 - Tuners are available in vertical and horizontal mounting
 - Small size (50mm x 44mm x 14mm)
-
- RF-in to RF-out loopthrough amplifiers
 - Low noise and excellent linearity
 - Full VHF to UHF frequency range coverage
 - Standard connectors for in- and output e.g. IEC, F- and RCA-connector on request
-
- High performance and cost effective single conversion tuner
 - I²C programmable
 - 3.3V and 5V Bus compliant with max. 400kHz clock
 - Fast PLL tuning speed (programmable step size e.g. 62.5kHz and 166.67kHz)
 - Tuner internal gain control loop with selectable TakeOverPoint settings via I²C Bus
 - External gain control possible with internal loop disabled
 - 4.0V (max. gain) to 0V (min. gain) gain control voltage
 - Flat overall frequency response
 - Low Phase Noise PLL
 - 4 MHz crystal reference frequency output
 - SAW-filter and IF-amplifier included
 - Switchable 7/8 MHz or fixed 8MHz SAW filter
 - IF-amplification controllable over a wide range
 - Differential IF-output filtered by SAW filter; can directly drive the channel decoder
 - Unbalanced (wide-band) IF-output for analog applications



Tuner modules for analog and digital terrestrial (OFDM) applications

TD1300A(L)F-3

ORDERING INFORMATION

	Type name	Ordering code	Specialities
VHF – UHF full-band PLL tuner	With RF-Loopthrough		
	TD1316ALF/IHP-3	Tbd	horizontal mounting
	TD1316ALF/IVP-2	Tbd	vertical mounting
	Without RF-loopthrough		
	TD1316AF/IHP-3	Tbd	horizontal mounting
	TD1316AF/IVP-3	tbd	vertical mounting
VHF – UHF 2-Band PLL tuner	With RF-Loopthrough		
	TD1311ALF/IHP-3	tbd	horizontal mounting
	TD1311ALF/IVP-3	tbd	vertical mounting
	Without RF-loopthrough		
	TD1311AF/IHP-3	tbd	horizontal mounting
	TD1311AF/IVP-3	tbd	vertical mounting
UHF – only PLL tuner	With RF-Loopthrough		
	TD1344ALF/IHP-3	tbd	horizontal mounting
	TD1344ALF/IVP-3	tbd	vertical mounting
	Without RF-loopthrough		
	TD1344AF/IHP-3	www.DataSheet.U.com tbd	horizontal mounting
	TD1344AF/IVP-3	tbd	vertical mounting



Tuner modules for analog and digital terrestrial (OFDM) applications

TD1300A(L)F-3

PRODUCT DESCRIPTION

TD1300ALF-3 belong to the 3rd generation of terrestrial tuners designed to cope with digital COFDM and analog transmission standards.

From function point-of-view these tuners can be divided into two high-frequency sections, a RF-loopthrough and a single conversion tuner part.

In the loopthrough section broadband low-noise amplifiers are used. The loopthrough frequency response covers the entire frequency range from VHF to UHF.

The RF-downstream section is equipped with a state-of-the-art 3-band single conversion tuner, which makes use of a highly integrated MOPLL IC that provides the required high level of performance necessary for COFDM signal processing.

The tuners are provided with a DC/DC converter to generate the tuning voltage internally.

The internal 4MHz PLL crystal reference frequency is fed through one of the pin-terminals and can be used as a clock for a 2nd device e.g. the channel decoder.

Two IF-outputs are provided, one is a wideband, non filtered IF-output, while the other, narrow-band IF-output is equipped with a SAW-filter and a gain controllable IF-amplifier. This narrow-IF-output matches the A-to-D converter input of currently available channel decoders.

All tuners out of this family can be equipped with two standard IEC-connectors, RF-in is IEC-female, RF-out is IEC-male. The tuner housing is available in a vertical or horizontal mountable execution; the pinning pitch corresponds to the World Standard Pinning convention.

Apart from the RF-connectors, all other terminals are made with wire pins at the bottom side of the tuner.

Frequency allocation table:

	TD1316A(L)F	TD1311A(L)F	TD1344A(L)F
RF frequency range	51MHz – 858MHz (*)	174MHz – 858MHz (*)	474MHz – 858MHz (*)
Channel bandwidth	7/8MHz	7/8	8 MHz
RF-loopthrough range	Ch E2 - ch E69	ch E2 - ch E69	ch E2 - ch E69
IF-center frequency	36.13MHz	36.13MHz	36.13MHz
RF input connector	IEC female	IEC female	IEC female
RF output connector	IEC male	IEC male	IEC male

(*) data refer to RF-channel center frequency.



Tuner modules for analog and digital terrestrial (OFDM) applications

TD1300A(L)F-3

BLOCK DIAGRAMM

TD1316A(L)F-3 , TD1344A(L)F-3 , TD1311A(L)F-3

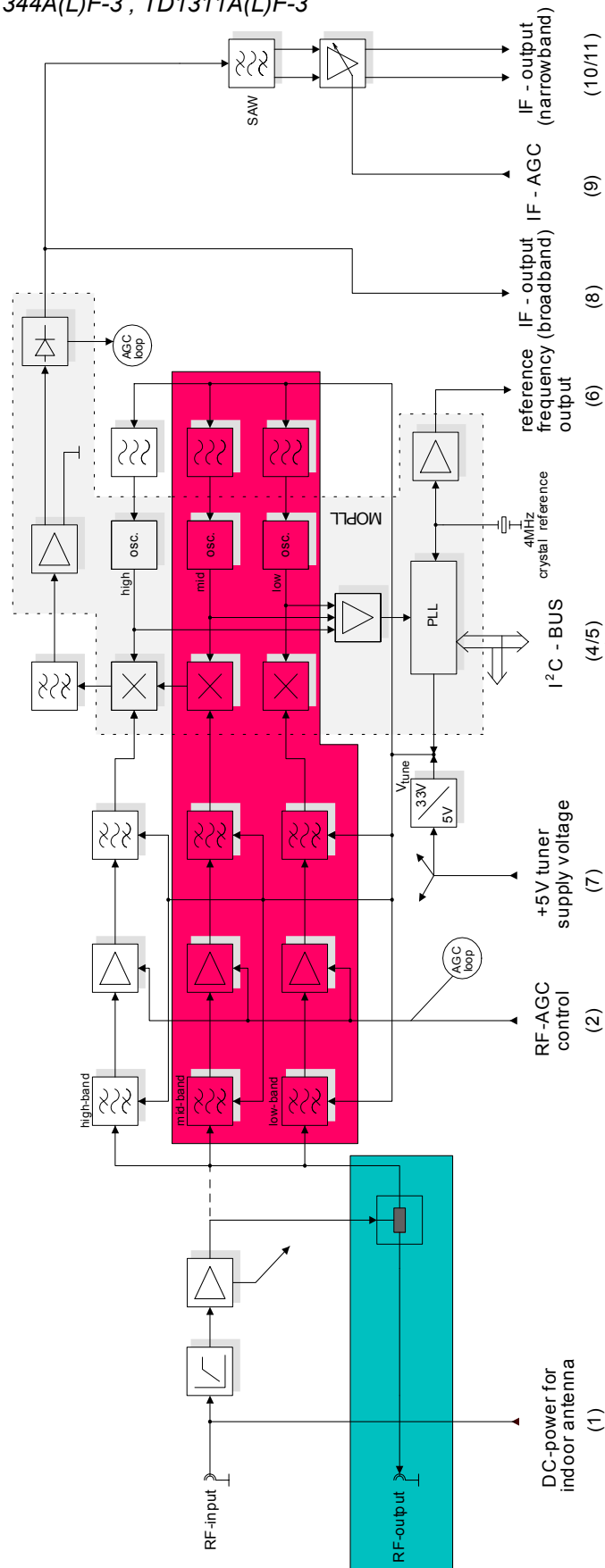

Tuner modules for analog and digital terrestrial (OFDM) applications

TD1300A(L)F-3

DEFINITION OF TERMINALS / SUPPLY DATA

TD1316A(L)F / TD1344A(L)F / TD1311A(L)F

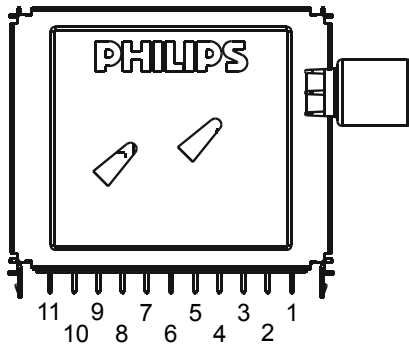

Terminal	Function	Remark
1	DC-power option for tuners with P-extension	Max. permissible current: 100mA
2	External RF-gain control voltage (0.5V - 4.0V)	Source impedance limited to 1kohms
3	PLL chip address select (I ² C / tuner)	see application notes
4	SCL (I ² C / tuner)	
5	SDA (I ² C / tuner)	
6	4MHz reference frequency output;	AC coupled
7	+5V \pm 5% supply tuner (V _{TU})	
8	'broadband' IF - output	AC coupled
9	IF-gain control voltage	max. gain at 3V min. gain at 0V (see application notes)
10	'narrowband' IF - output	AC coupled
11	'narrowband' IF - output	AC coupled



Tuner modules for analog and digital terrestrial (OFDM) applications

TD1300A(L)F-3

RATINGS

Environmental conditions

SYMBOL	PARAMETER	CONDITIONS	MIN.	MAX.	UNIT
Non-operational Conditions					
T_{AMB}	Ambient temperature		-25	+85	°C
RH	Relative humidity		-	95	%
g_B	Bump acceleration	25g	-	245	m/s ²
g_S	Shock acceleration	50g	-	490	m/s ²
	Vibration amplitude	10 to 55 Hz	-	0.35	mm
Operational conditions					
T_{AMB}	Ambient temperature		-10	+60	°C
RH	Relative humidity		-	95	%

Limiting values under operational conditions

The tuner can be guaranteed to function properly under the following conditions.

www.DataSheet4U.com

SYMBOL	PARAMETER	PIN	MIN	TYP.	MAX.	UNIT
V_L	DC-loopthrough to input connector (optional) Max. permissible current	1			20	V
I_L					100	mA
V_{TU}	Tuner supply voltage Relevant supply current	7	4.75	5.00	5.25	V
I_{TU}			-	185	205	mA
V_{ripple}	Max. permissible ripple voltage (50Hz – 100kHz) ⁽¹⁾	7			10 ⁽¹⁾	mVpp
V_{AGC}	Tuner AGC voltage	2	-	4.0	4.5	V
ΔV_{AGC}	AGC voltage range		0.3	-	4.0	V



Tuner modules for analog and digital terrestrial (OFDM) applications

TD1300A(L)F-3

I_{AGC}	AGC control current		-	-	t.b.f.	mA
V_{IF-AGC}	IF- AGC input voltage	9	-	3.0	4.0	V
ΔV_{IF-AGC}	IF- AGC input voltage range		0	-	3.5	V
I_{IF-AGC}	IF- AGC input current		-	-	10	μ A
V_{AS}	Address select input voltage	3	-	-	5.25	V
V_{SCL}	Serial clock input voltage	4	-0.3	-	5.25	V
V_{SDA}	Serial data input voltage	5	-0.3	-	5.25	V
I_{SDA}	Serial data input current		-1	-	5	mA

Note 1: Maximum allowable ripple voltage superimposed on the +5V supply voltage in the frequency range 50Hz to 100kHz;

Worst case the combination of tuner plus COFDM channel decoder (e.g. Philips Semiconductors COFDM reference board OM5754)

can withstand a max. +5V supply voltage ripple of 10mVpp of which the most sensitive ripple frequency is between 500Hz and 1kHz.

Specification criteria is: 8k OFDM, 64QAM, BER 2×10^{-4} post Viterbi



Tuner modules for analog and digital terrestrial (OFDM) applications

TD1300A(L)F-3

SPECIFICATION DATA

If not otherwise stated the electrical performance refers to:

- ambient temperature : 22°C ±2°C
- relative humidity : 60% ±10%
- supply voltages : 5V ±0.1V
- RF-gain control voltage : 4.0V ±0.1V (internal AGC detector disabled; see application notes)
- IF-gain control voltage : 1V max.
- RF-input termination : 75 ohms
- RF-output termination : 75 ohms

Next specification data refer to the overall performance from RF-input to IF-output.

If not otherwise stated, all data are assigned to broadband IF-output.

The tuner has to be tuned as such that coincidence between RF-channel center and IF-center frequency of 36.13MHz is given.

	MIN.	TYP.	MAX.
<i>Frequency ranges (VHF/UHF) ⁽¹⁾</i>			
<i>(VHF low) low-band</i>	49MHz		159MHz
<i>(VHF high) mid-band</i>	162MHz		444MHz
<i>(UHF) high-band</i>	448MHz		861MHz
<i>UHF only tuners</i>	474MHz		861MHz
<i>RF voltage gain ⁽²⁾</i>	44dB	49dB	
<i>Overall gain taper</i>	<small>www.DataSheet4U.com</small>	6dB	
<i>RF AGC range</i>			
<i>Low band</i>	40dB		
<i>Mid band</i>	40dB		
<i>High band</i>	35dB		
<i>Image rejection</i> <i>(referred to IF-center frequency)</i>			
<i>(VHF low) low-band</i>	66dB	70dB	
<i>(VHF high) mid-band</i>	66dB	70dB	
<i>(UHF) high-band</i>	55dB	60dB	
<i>Osc. voltage at aerial input</i> <i>(f < 1000MHz)</i>		<20dBμV	
<i>RF-input return loss (75ohms)</i>	5dB	>7dB	
<i>In-channel return loss ⁽³⁾</i>		8dB	
<i>Noise figure (at nom. gain)</i>		5dB	7dB
<i>ESD protection of terminals</i>	2kV		
<i>Surge protection at RF-input</i>	5kV		
<i>Osc. phase noise ⁽⁴⁾</i> <i>(1kHz)</i> <i>(10kHz)</i>			-73dBc/Hz -73dBc/Hz
<i>Overall voltage gain ⁽⁵⁾</i>		80dB	

Note 1: channel center including tuning margin

Note 2: to be measured at 'broadband' IF-output with 1kohms load

Note 3: to be measured at RF-input in the range channel-center ± 3MHz

Note 4: PLL step size 166.667kHz; CP as recommended (see application notes)

Note 5: measured at narrow band IF-output terminals 10/11; IF-AGC voltage (terminal 9) set to 3V



Tuner modules for analog and digital terrestrial (OFDM) applications

TD1300A(L)F-3

Cross-modulation:

Definition: The cross-modulation is defined as the transfer of the adjacent channels' modulation depth to the wanted carrier.

Measurement:

- Unwanted carriers (f_{unw}) = wanted carrier (f_w) \pm 8MHz
- Level of all carriers = 70dB μ V
- Modulation = AM, 50%, 15kHz
- IF-output loaded with 1k Ω // 15pF // 1.2uH (load compensation)
- IF-output level limited to 104dB μ V

Spec. limit: max. cross-modulation is less or equal 1% (typ. 0.3%)

Flatness (tilt) of overall responds curve (to be measured at broad-band IF-output):

Definition: tilt of curve is defined in the specified IF-range from highest to lowest gain point at nom. gain

Measured at broadband IF-output:

- in the range IF-center \pm 3MHz : 3dB max.
- in the range IF-center \pm 4MHz : 4dB max.

Deterioration of flatness during AGC (0dB to 30dB) : 1.0dB max.

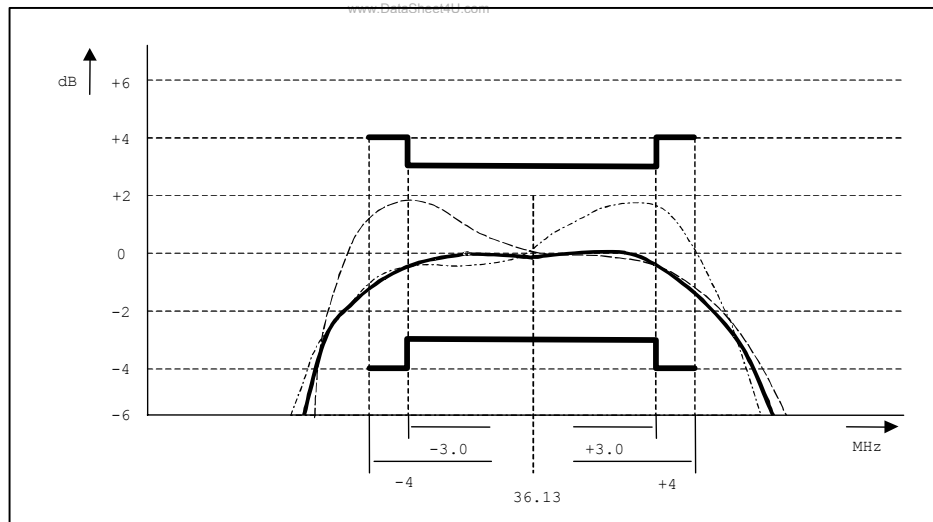

Input sensitivity:

The typical input sensitivity, when measured in an adequate application (i.e. Philips Semiconductors COFDM reference board OM5754) is: - 82dBm , BER 2×10^{-4} post Viterbi

Conditions: Gaussian channel w/o added noise, 8k OFDM, 64QAM, code rate 2/3, guard interval 1/8



Tuner modules for analog and digital terrestrial (OFDM) applications

TD1300A(L)F-3

Typical response curves at narrowband IF-output (tuner set to 470MHz):

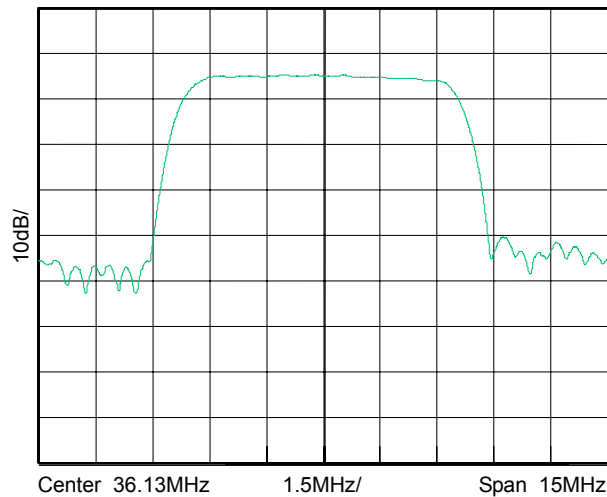

7MHz wide SAW-filter selected

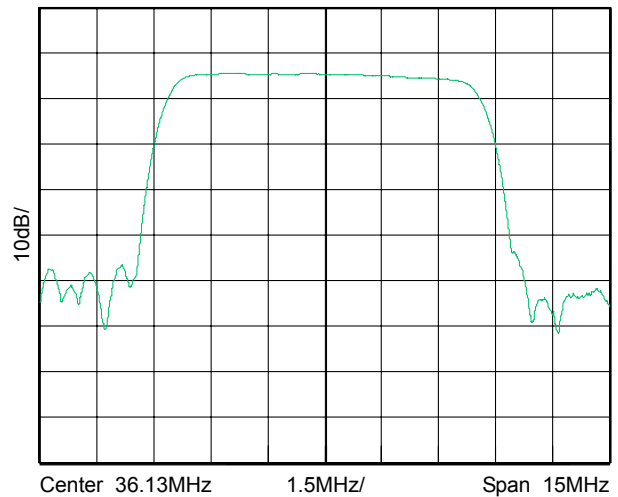

8MHz wide SAW-filter selected (UHF only tuners)

4MHz reference output (terminal 6):

www.DataSheet4U.com

- Frequency accuracy : 80ppm max.
- Max. permissible load : t.b.f.
- Output level : 440mVpp typ.
- [0°C - 60°C ;
- supply voltage (terminal 7) +5V±5% ;
- loaded with min. t.b.d.]
- Phase Noise @ 1kHz : -104dBc/Hz typ.

Next specification data refer to the overall performance from RF-input to RF-output. (valid for all tuners with loopthrough)

	MIN.	TYP.	MAX.
Frequency range (referred to channel center)	51MHz		858MHz
Power gain		3dB	
Overall gain taper		2.5dB	
Noise figure		5dB	
CSO / CTB (acc. EN50083)	-57dBc		
RF-output return loss (referred to 75Ω)		10dB	



Tuner modules for analog and digital terrestrial (OFDM) applications

TD1300A(L)F-3

APPLICATION NOTES

Programming of tuner PLL

The tuner control (frequency selection and band switching) is done via the I²C bus.

One address byte and four data bytes are needed to fully program the tuner.

A PLL lock flag can be read from the tuner during 'READ' - mode.

Four independent PLL addresses are available; which one is actually valid depends on the address select voltage that is connected to terminal 3.

All tuners out of this family are 3.3V and 5V I²C Bus level compliant.

I²C-bus data format , ' WRITE ' - mode:

NAME	BYTE	MSB							LSB	ACK
Addressbyte	1	1	1	0	0	0	CA1	CA0	R/W=0	A
Prog. Divider Byte 1	2	0	N14	N13	N12	N11	N10	N9	N8	A
Prog. Divider Byte 2	3	N7	N6	N5	N4	N3	N2	N1	N0	A
Control Data Byte	4	1	CP	T2	T1	T0	R1	R0	0	A
Switchport Byte	5a	0	0	0	SP4	SP3	SP2	SP1	SP0	A
Auxiliary Byte (*)	5b	AGC	AL2	AL1	AL0	0	0	0	0	A

A = acknowledge

Description of used symbols:

www.DataSheet4U.com

CA1, CA0 : chip address selection bits (see table: Programmable address selection bits)

R/W : Read / Write bit ; Bit = 0 ⇒ Write mode
Bit = 1 ⇒ Read mode

N14 to N0 : LO frequency divider bits

CP,T2, T1, T0 : PLL charge pump settings;
T2, T1, T0 = 0, 1, 1 ⇒ Switchport byte (5a) is replaced by Auxiliary byte (5b)

R1, R0 : reference divider bits

SP4 SP0 : Band selection and SAW filter switch ports; Stand-by on: SP1, SP0 = 1, 1

AGC : AGC time constant Bit; AGC = 0 ⇒ low AGC current result in high time constant
AGC = 1 ⇒ high AGC current result in low time constant

AL2, AL1, AL0 : RF-AGC loop Take Over Point (TOP) bits

CA1, CA0: Programmable address selection bits

CA1	CA0	Voltage applied to terminal 3
0	0	0V to 0.1xV _{TU}
0	1	terminal open
1	0	0.4xV _{TU} to 0.6xV _{TU}
1	1	0.9xV _{TU} to 1.0xV _{TU}



Tuner modules for analog and digital terrestrial (OFDM) applications

TD1300A(L)F-3

N14 to N0: programmable divider bits

divider ratio: $N = N14 \times 2^{14} + N13 \times 2^{13} + \dots + N1 \times 2^1 + N0$

How to calculate the programmable divider ratio N :

$$N = \frac{(f_{input} + f_{IF})}{f_{ref}} \left[\frac{Hz}{Hz} \right] \quad \text{whereby} \quad f_{ref} = \frac{4 \cdot 10^6}{64^{(1)}} [Hz] = 62.5kHz$$

$$f_{ref} = \frac{4 \cdot 10^6}{24^{(1)}} [Hz] = 166.6\bar{6}kHz$$

Note ⁽¹⁾ : reference divider ratio to be set with Bits ' R1/ R0 ' (see table below)

Do not set the divider ratio as such that the tuner is tuned into extreme conditions i.e. far below or far above the specified ranges.

T2, T1, T0: PLL charge pump current settings (**Control Data Byte**):

Note: during search tuning it is recommended to set the PLL charge pump current to 'low'. After channel acquisition the charge pump current should be set to conditions as indicated in below table.

www.DataSheet4U.com

CP	T2	T1	T0	PLL charge pump	Oscillator frequency
0	1	1	1	Low CP	84MHz < Low-band oscillator <180MHz 197MHz < Mid-band oscillator <366MHz 484MHz < High-band oscillator <646MHz
1	1	1	0	Medium CP	Low-band oscillator >180MHz Mid-band oscillator >366MHz 646MHz < High-band oscillator <790MHz
1	1	1	1	High CP	High-band oscillator >790MHz
0/1 *	0	1	1		Auxiliary byte enabled

*** NOTE:** After the CP-Bit has been set and the auxiliary byte is going to be addressed , the CP-Bit must remain unchanged !

R1, R0: PLL reference divider settings (**Control Data Byte**):

PLL step size	PLL ref. divider ratio	R1	R0
166.67 kHz	24	1	0
62.5 kHz	64	1	1



Tuner modules for analog and digital terrestrial (OFDM) applications

TD1300A(L)F-3

SP4 SP0: Band and SAW-filter selection table (**Switchport Byte**):

	SP4	SP3	SP2	SP1	SP0
Low - band	0	X	0	0	1
mid - band	0	X	0	1	0
High - band	0	X	1	0	0
7 MHz SAW - filter	0	0	X	X	X
8 MHz SAW - filter	0	1	X	X	X
Stand-By mode	X	X	X	1	1

AL2, AL1, AL0 : tuner internal gain control loop settings (**Auxiliary Byte**):

To have access to the AGC loop 'Take Over Point' bits, the control byte bits T2, T1, T0 must be set to 0, 1, 1 .

External AGC mode: The tuner can be controlled by an external gain control voltage applied to terminal 2 of the tuner.

In that case the ALx - bits need to be set as shown in table below.

AL2	AL1	AL0	AGC loop TOP	Remarks
0	0	1	High (0dB reference)	Range recommended for DVB-T applications
0	1	0	Medium -3dB	
0	1	1	Low -6dB	
1	0	0	-9dB	Recommended for PAL applications
1	0	1	-12dB	
1	1	0	$I_{AGC} = 0$	External AGC (1)
1	1	1	$V_{AGC} = 3.5V$	Loop disabled (2)

Note 1: The tuner internal AGC current sources are disabled

Note 2: The tuner internal AGC detector is disabled. With no external AGC voltage applied to the tuner, the RF-gain is always set to maximum.

I²C-bus data format , 'READ' - mode:

Name	MSB						LSB			
Address byte	1	1	0	0	0	CA1	CA0	R/W=1	A	
Status byte	POR	FL	1	1	AGC	0	0	0	A	

A : Acknowledge

CA1 / CA0 = chip address (see address selection table)

POR = power-on-reset-flag ; POR = 1 after power-on

FL = in-lock-flag ; FL = 1 when PLL is phase locked

AGC = internal AGC flag ; AGC = 1 when internal AGC is active



Tuner modules for analog and digital terrestrial (OFDM) applications

TD1300A(L)F-3

Default settings of tuner PLL at power-on reset:

NAME	BYTE	MSB							LSB	
Addressbyte	1	1	1	0	0	0	CA1	CA0	0	
Prog. Divider Byte 1	2	0	X	X	X	X	X	X	X	
Prog. Divider Byte 2	3	X	X	X	X	X	X	X	X	
Control Data Byte	4	1	1	0	0	1	X	X	1	
Switchport Byte	5a	0	0	0	0	0	0	0	0	
Auxiliary Byte (*)	5b	0	0	1	0	0	0	0	0	

X = don't care

Telegram Examples:

START – addressbyte – divider byte1 – divider byte 2 – control byte – switchport byte - STOP

START – addressbyte – divider byte1 – divider byte 2 – control byte – auxiliary byte - STOP

START – addressbyte – divider byte1 – divider byte 2 – STOP

START – addressbyte – control byte – switchport byte – STOP

START – addressbyte – control byte – auxiliary byte – STOP

I²C-bus timing:

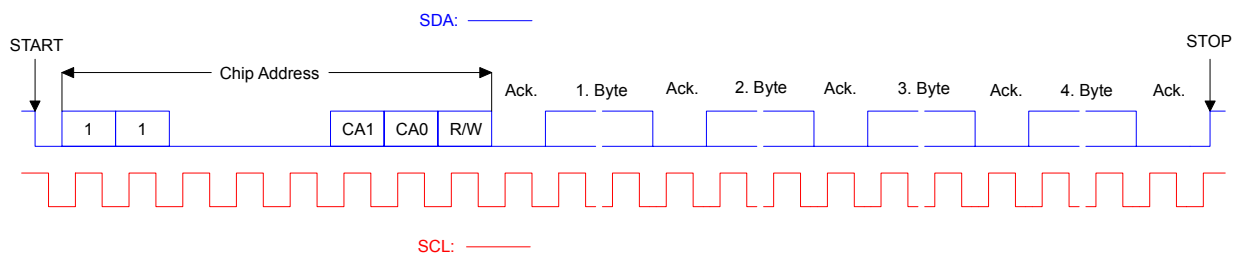

Tuner modules for analog and digital terrestrial (OFDM) applications

TD1300A(L)F-3

Max. IF-output level:

For analog, PAL applications it is advisable to set the internal RF-gain control loop Take Over Point to:

$$AL2, AL1, AL0 = 1, 0, 1$$

Max. Permissible IF-load impedance:

The max. load applied to the ' broadband ' IF-output of the tuner should not exceed:

$$1k\Omega \text{ min.} // 15pF \text{ max.}$$

The reactive load has to be compensated (tuned-out to the IF-center frequency) by an inductance connected in parallel to the load.

The max. load applied to the ' narrowband ' balanced IF-output of the tuner is limited to $1k\Omega \text{ min.}$.

Gain control characteristic of IF-amplifier (terminal 9) :

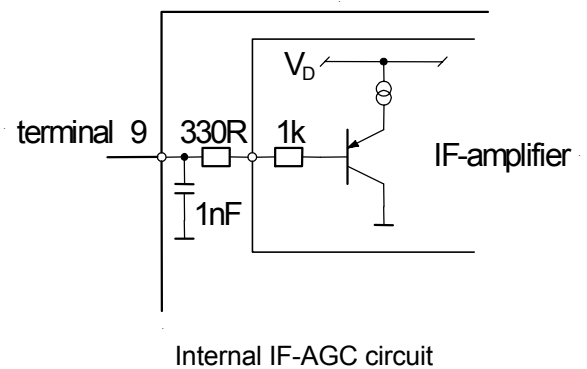
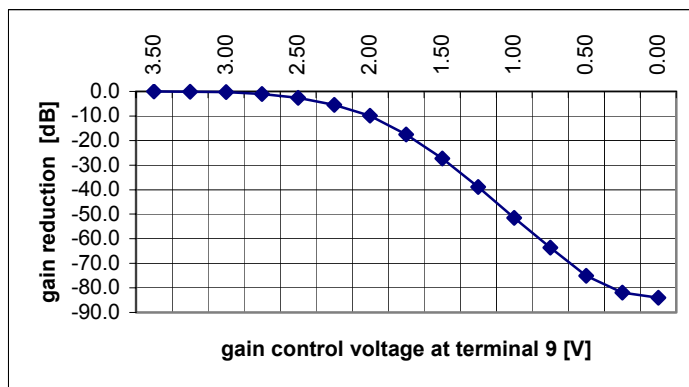

Tuner modules for analog and digital terrestrial (OFDM) applications

TD1300A(L)F-3

External RF-Gain Control Voltage and Tuner Supply Voltage; recommended schematic

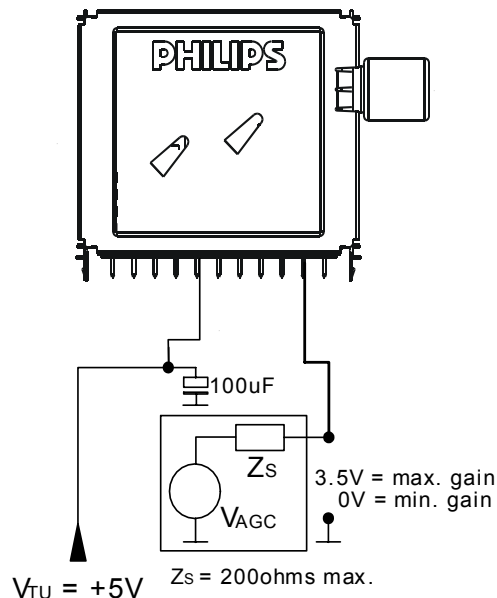

www.DataSheet4U.com

Phase noise, I²C bus traffic and crosstalk

The low noise PLL used in these tuners will clean up the noise spectrum of the VCOs close to the carrier to reach noise levels @ 1 kHz offset from the carrier compatible with e.g. OFDM reception.

Linked to this noise improvement, some disturbances may become visible while they were not visible because they were hidden into the noise in analog dedicated applications and circuits.

This is especially true for disturbances coming from the I²C bus traffic, whatever this traffic is intended for the MOPLL or for another slave on the bus.

To avoid this I²C bus crosstalk and be able to have a clean noise spectrum, it is necessary to use a bus gate that enables the signal on the bus to drive the MOPLL. This is used only when the communication is intended for the tuner part (such a kind of I²C bus gate is included into the Philips terrestrial channel decoders), and to avoid unnecessary repeated sending of the same information.

Main board recommendations :

The tracks on the main board connected to the tuners' terminals should be kept as short as possible in order to avoid interferences because of immunity problems and/or to avoid problems with regard to radiation of the local oscillator.

For tuners with antenna-power function (tuners with type name extension "P")

Attention:

Tuners with type name extension 'P' do have the DC-supply option through out the RF-input connector on board. The max. permissible current drive is limited to 100mA .



Tuner modules for analog and digital terrestrial (OFDM) applications

TD1300A(L)F-3

PACKAGING INFO

The products are packed in the carton box and transferred to customers by Pallet Transport.

IEC types	Dimension b x w x h (cm)	No. of sets	Gross Wt (Kg)
Carton	46 x 34 x 12.2	98	4.1
Pallet	120 x 105 x 105	7742	345.1

Carton Boxes are made of Corrugated Fibreboard which are free of environmentally banned substances.

Example of Carton Box:

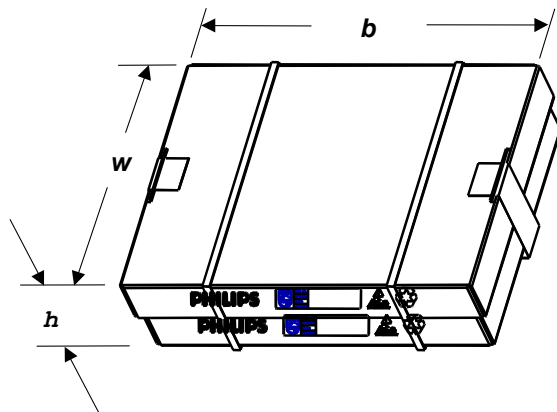

Tuner modules for analog and digital terrestrial (OFDM) applications

TD1300A(L)F-3

MECHANICAL DIMENSIONS

general tolerances $\pm 0.5\text{mm}$ unless otherwise stated / all dimensions in millimeter / drawings not to scale

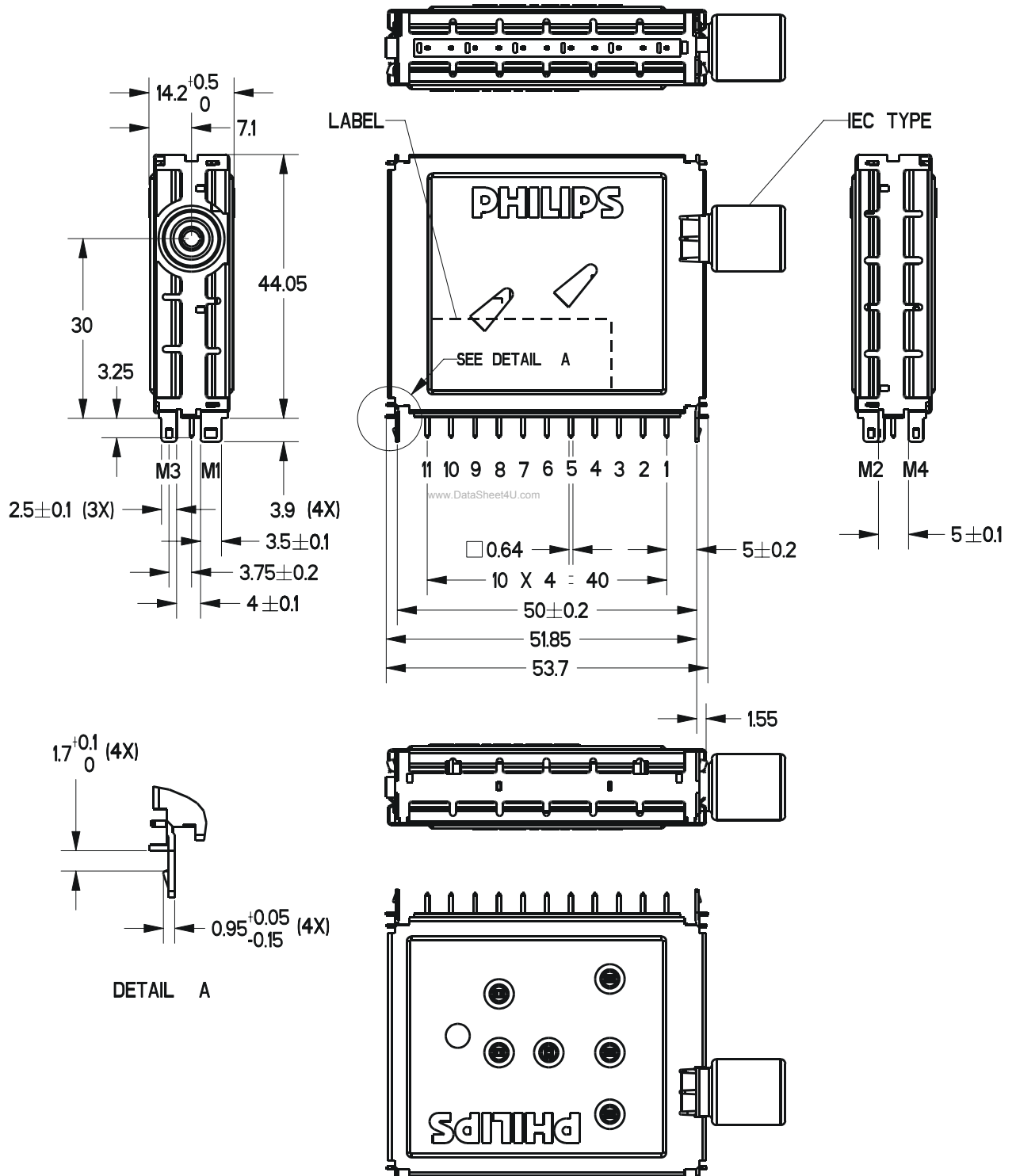

VERTICAL MOUNTING



Tuner modules for analog and digital terrestrial (OFDM) applications

TD1300A(L)F-3

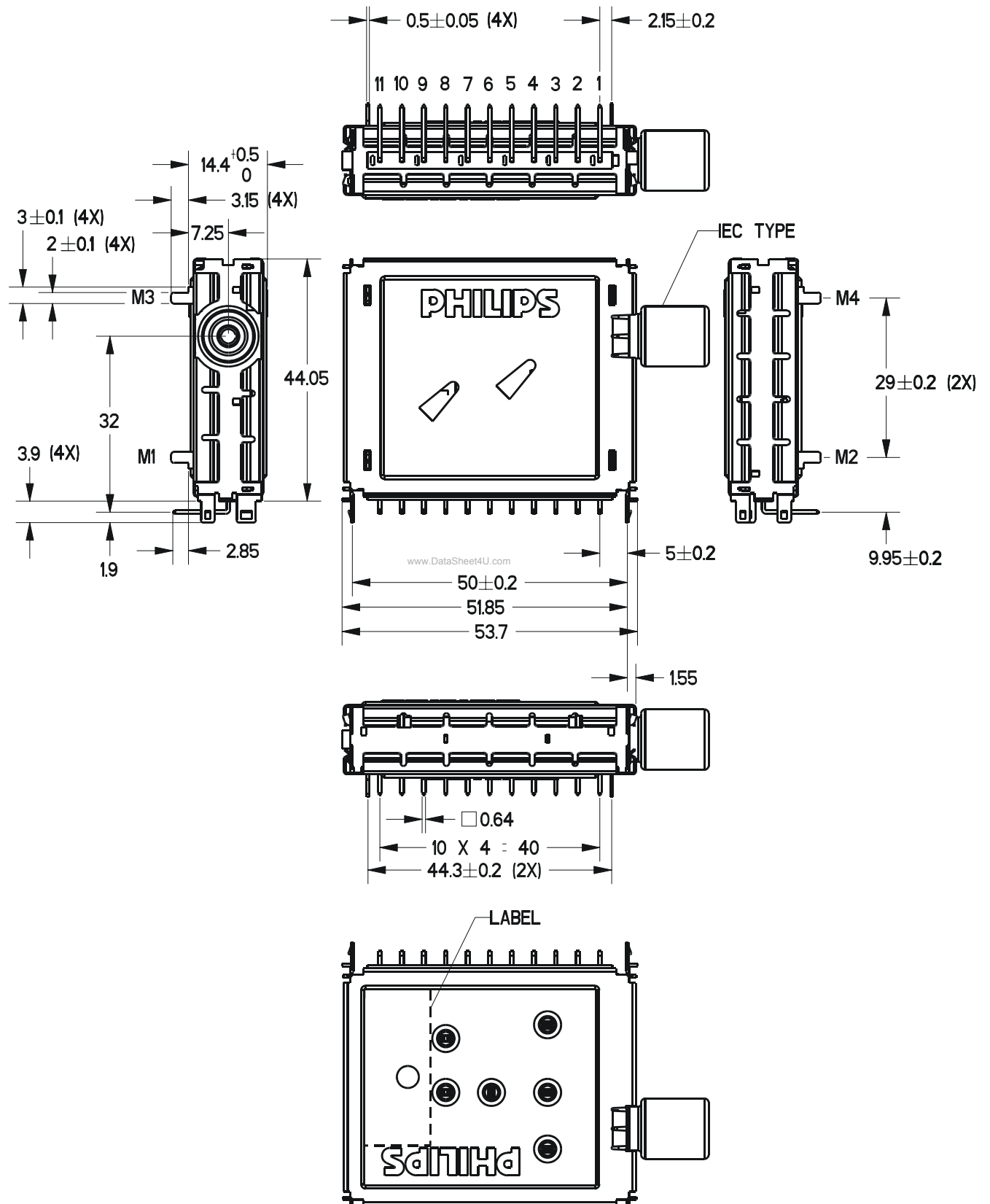

HORIZONTAL MOUNTING



Tuner modules for analog and digital terrestrial (OFDM) applications

TD1300A(L)F-3

PUNCHING PATTERN OF CHASSIS PCB

PUNCHING PATTERN SEEN FROM SOLDER SIDE

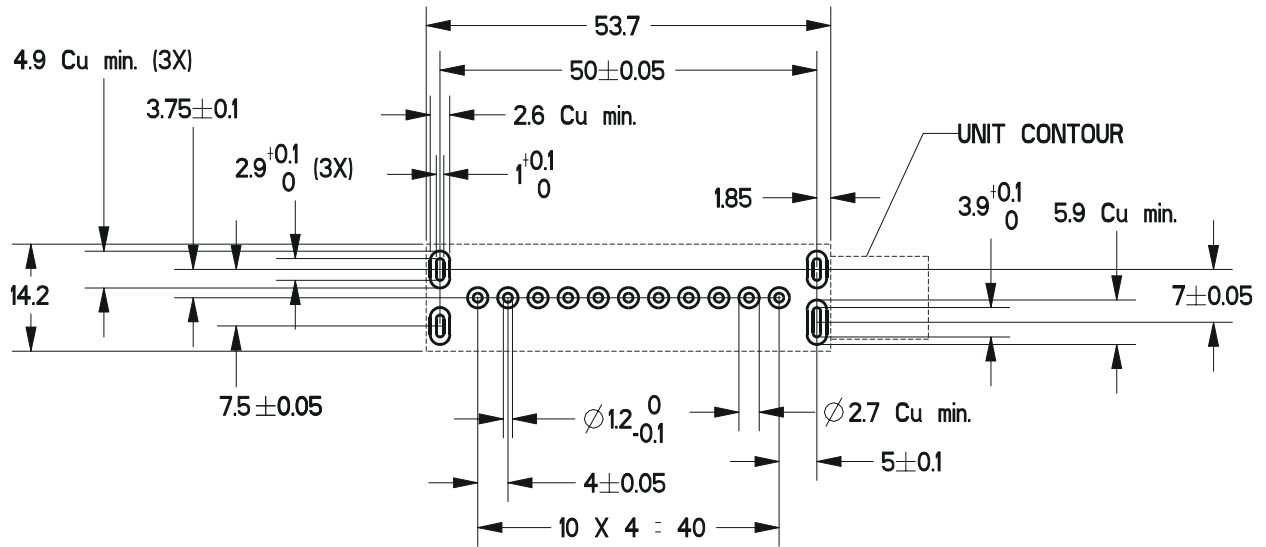

VERTICAL MOUNTING

www.DataSheet4U.com

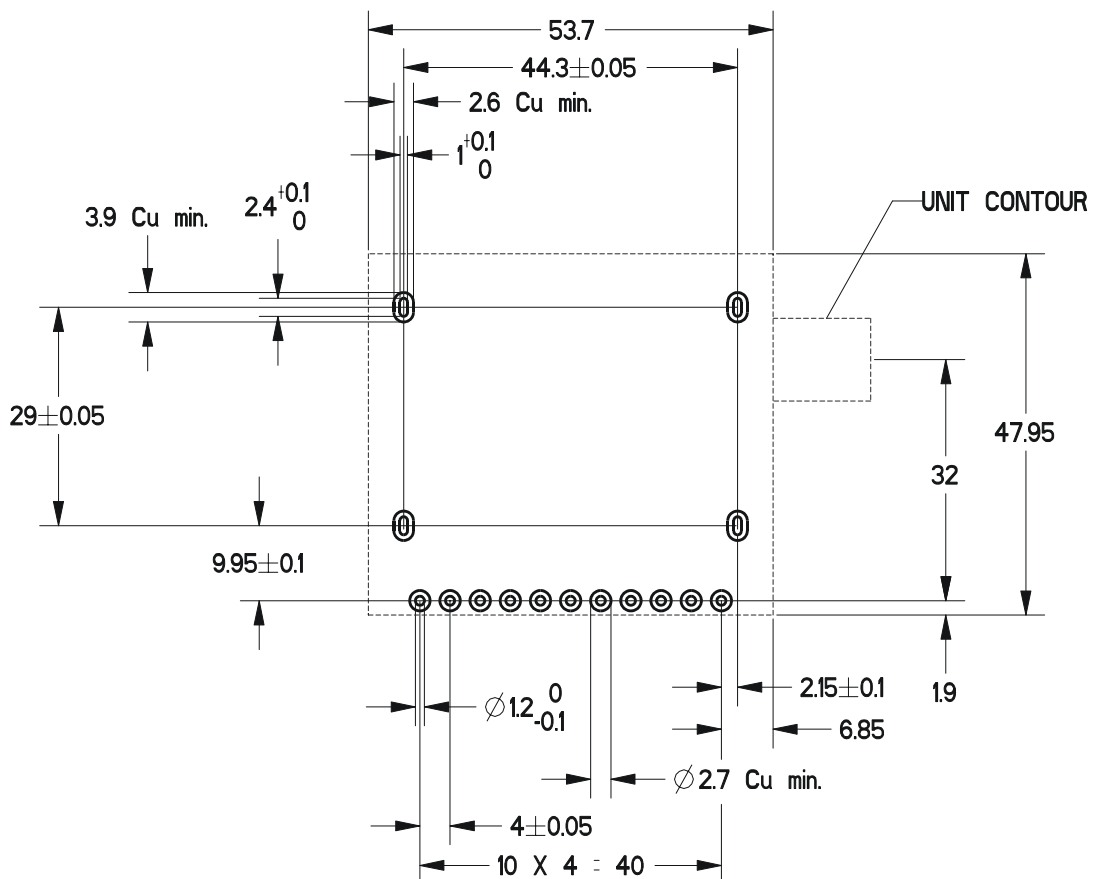

HORIZONTAL MOUNTING



Tuner modules for analog and digital terrestrial (OFDM) applications

TD1300A(L)F-3

RF-connector data; RF-input is standard IEC female; RF-output is standard IEC male:

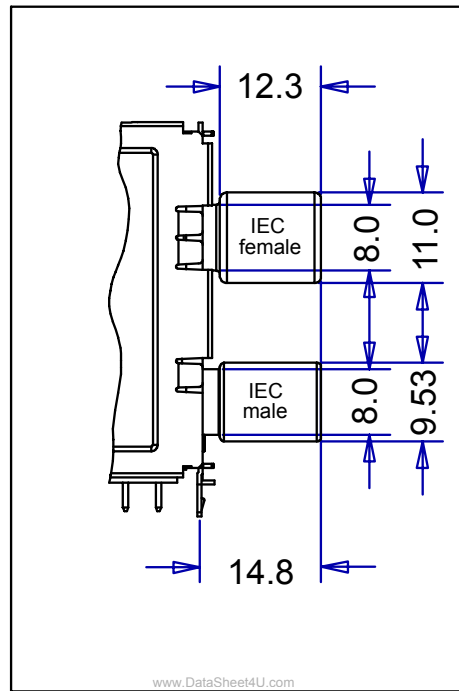

Tuner modules for analog and digital terrestrial (OFDM) applications**TD1300A(L)F-3****DOCUMENT REVISION HISTORY**

<i>Date</i>	<i>Document status</i>	<i>Rev. no.</i>	<i>Revised by</i>	<i>Revision details</i>
03.05.2005	Objective spec.	a	Y.Kalafat	First draft



Tuner modules for analog and digital terrestrial (OFDM) applications

TD1300A(L)F-3

DEFINITIONS

Data sheet status	
Objective specification	This data sheet contains target or goal specifications for product development.
Preliminary specification	This data sheet contains preliminary data; supplementary data may be published later.
Product specification	This data sheet contains final product specification.
Application Information	
Where application information is given, it is advisory and does not form part of the specification	

LIFE SUPPORT APPLICATIONS

These products are not designed for use in life support appliances, devices, or systems where malfunction of these products can reasonably be expected to result in personal injury. Philips customers using or selling these products for use in such applications do so at their own risk and agree to fully indemnify Philips for any damages resulting from such improper use or sale.

PURCHASE OF PHILIPS I²C COMPONENTS



Purchase of Philips I²C components conveys a license under the Philips I²C patent to use the components in the I²C systems to the I²C specification defined by Philips. This specification can be ordered using the code 9398 393 40011.

RF Solutions Sales Offices

Refer to : Internet: www.rfsolutions.philips.com

© Philips Electronics N.V. 2005.

All rights are reserved. Reproduction in whole or in part is prohibited without the prior written consent of the copyright owner. The information presented in this document does not form part of any quotation or contract, is believed to be accurate and reliable and may be changed without notice. No liability will be accepted by the publisher for any consequence of its use. Publication thereof does not convey nor imply any license under patent- or other industrial or intellectual property rights.

