



---

## DISTINCTIVE CHARACTERISTICS (continued)

- Transposition of ternary to binary data and vice versa (coding, decoding, scrambling, descrambling, phase adaptation)
- Built-in wake-up unit for activation from power-down state
- Activation and deactivation procedure according to CCITT I.430 and to FTZ Guideline 1R 210 of the DBP
- Adaptation of internal interfaces to the current signal direction by programmable operation modes:  
LT: Line Terminator in public or private exchange  
NT: Network Terminator connected to SBC  
NT-PABX: Trunk Module (TMD)  
NT-TE: Terminal equipment  
LT-RP: U Repeater unit subscriber side  
NT-RP: U Repeater unit exchange side
- Optimized for working in conjunction with SBC via IOM interface
- Data speed conversion between the  $U_{30}$  frames and the IOM frames. In the LT and NT-PABX modes absorption of received phase-wander of up to 18  $\mu$ sec peak to peak (CCITT Rec. Q.512)
- Handling of commands and indications contained in the IOM C/I channel for (de-) activation, supervision of power supply unit and equipment for wire testing
- Data availability via the MONITOR channel:
  - accumulated RDS transmission errors; in the LT mode for the whole  $U_{30}$  link, in the NT mode only for those detected in the circuit itself
  - measurement value of the loop current
  - Echo canceller coefficients and status values, which can be used to give evidence of the state of "U" interface link
- Switching of an analog test loop at the  $U_{30}$  interface for testing as many units of the IEC as possible (loop 1 in LT, loop 4 in the repeater and loop 3 in the NT-PABX mode in reverse direction to the public exchange)
- Switching of a digital test loop as near to IOM as possible (loop 2 in NT-PABX and NT-TE)
- Remote control of test loop switching via maintenance channel
  - Test loop 2 in the SBC (NT mode)
  - Test loop 2 in the IEC near to the IOM interface in the NT-PABX and TE modes
  - Test loop 4 in the IEC LT-repeater mode near to the U-line
- Generation of a synchronized 7.68 MHz clock for the SBC in the mode

---

## GENERAL DESCRIPTION

The Am20901/20902 ISDN Echo Cancellation Circuit (IEC) is an advanced CMOS circuit for transmission over the  $U_{30}$  interface. The adaptive filter concept of the IEC is based on a highly digital approach which utilizes a sophisticated digital signal processing capability.

The Am20901/20902 enables digital full duplex voice/data transmission via the standard twisted pair telephone cable. (U interface) with a user bit rate of 144 kbps according to the ISDN standards. Together with the flexible IOM interface, it is fully compatible to operate with the Am2080 (SBC) devices and also enables a repeater (two IEC's back to back) for longer telephone loops.

The IEC is capable of operating in the following applications by means of pin strapping: the exchange, the net-

work termination, the terminal equipment, and the trunk model connecting a PABX to the public network.

At the present the IEC is available in a two chip set only.

A "Digital" Circuit, called IEC-D (PEB 20901) contains the digital receiver functions and the IOM™ - $U_{30}$  interface functions.

An "Analog" Circuit, called IEC-A (PEB 20902) contains the crystal oscillator and all of the analog functions of the line port, namely the A/D converter in the receive path and pulse shaping D/A converter and line driver in the transmit path.



# CONNECTION DIAGRAMS

## Top View

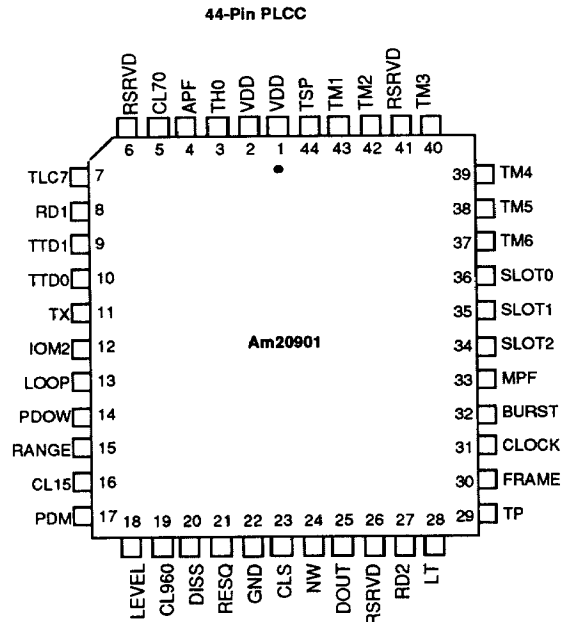
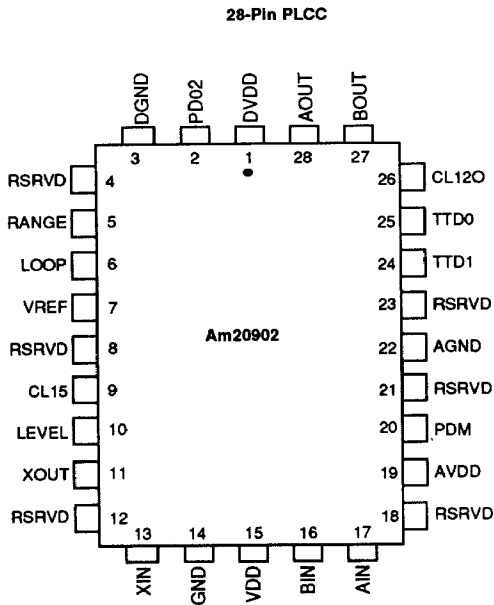
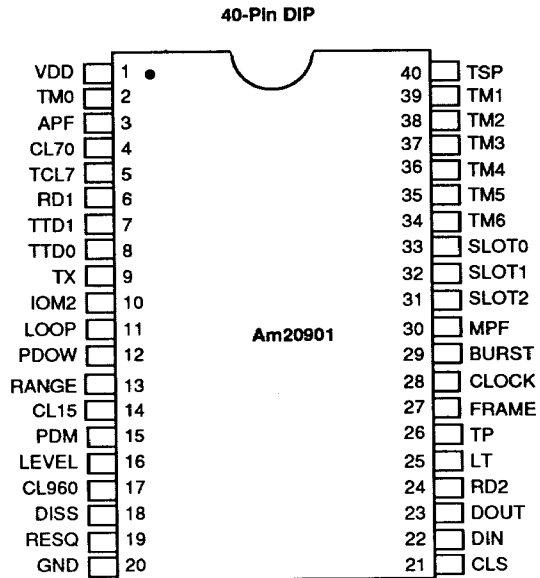
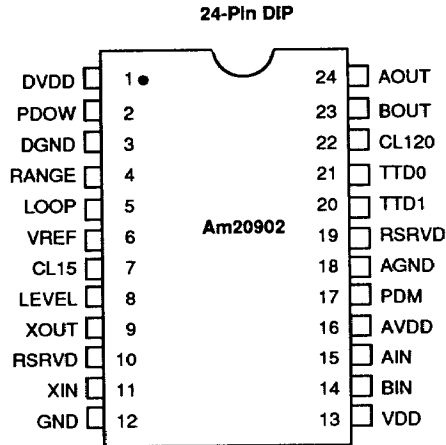

Note: Pin 1 is marked for orientation.



# LOGIC SYMBOL

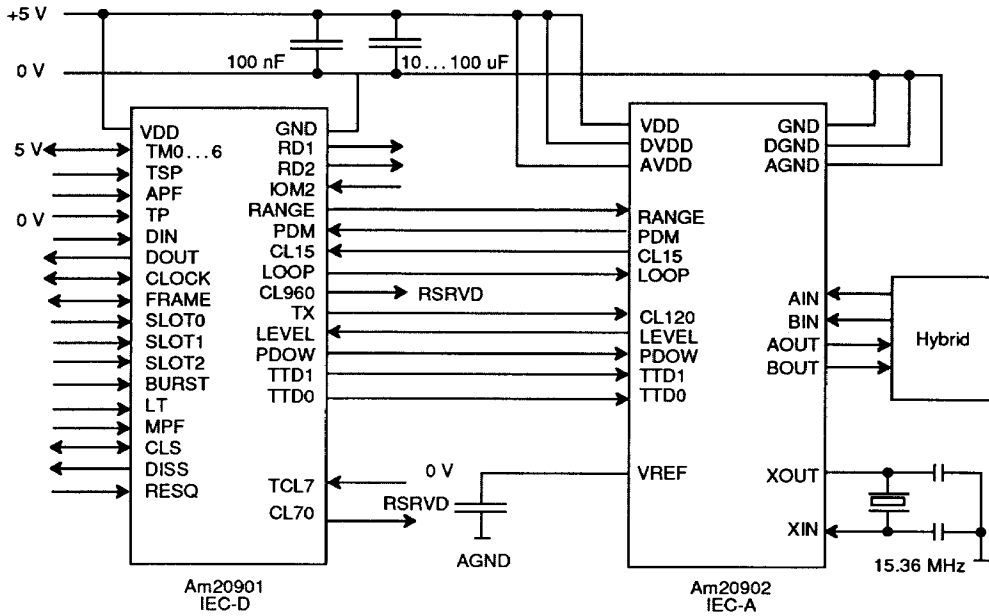

## ORDERING INFORMATION

### Standard Products

AMD standard products are available in several packages and operating ranges. The ordering number (Valid Combination) is formed by a combination of:

- a. Device Number
- b. Speed Option (If applicable)
- c. Package Type
- d. Temperature Range
- e. Optional Processing

**AM20901**  
**AM20902**

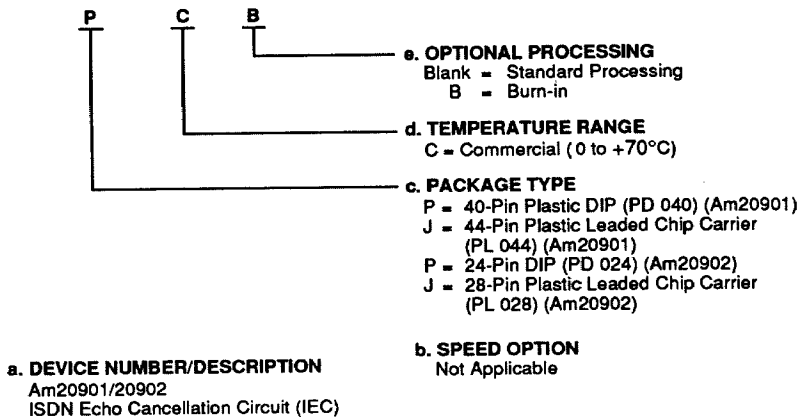

| Valid Combinations |                  |
|--------------------|------------------|
| AM20901            | PC, JC, PCB, JCB |
| AM20902            | PC, JC, PCB, JCB |

#### Valid Combinations

Valid Combinations list configurations planned to be supported in volume for this device. Consult the local AMD sales office to confirm availability of specific valid combinations, to check on newly released combinations, and to obtain additional data on AMD's standard military grade products.

\*The Am2090 is a two-chip set. It is ordered as an Am20901 and Am20902.

