

AN5179K

VIF/SIF signal processor IC for TV and VCR

Overview

The AN5179K is an integrated circuit for TV/VCR VIF and SIF, and improves the audio performance by using the QSS (Quasi Separate Sound) method and provides low power consumption with power supply of 5V.

Features

- PLL complete synchronous detection
- Reduction of buzz by QSS (Quasi Separate Sound) circuit
- External AGC pin for CATV de-scramble attached
- Video/audio mute SW built-in for external AV
- AFC output circuit uses another power supply V_{CC2} (V_{CC1} to 12V)
- DC volume circuit built-in
- Power supply operating range V_{CC1} : 5V (4.5 to 5.5V) typ.
- 30-pin shrunk DIL-plastic package

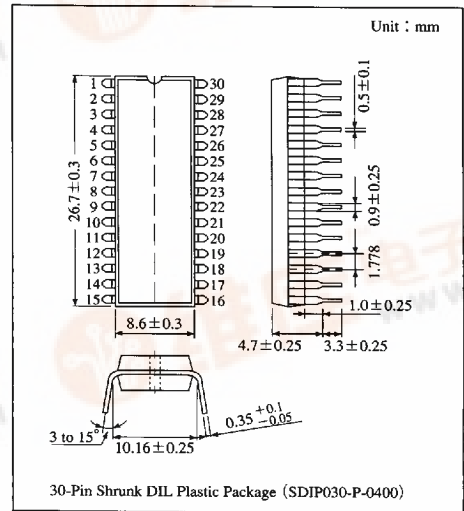

ICs for TV

Block Diagram

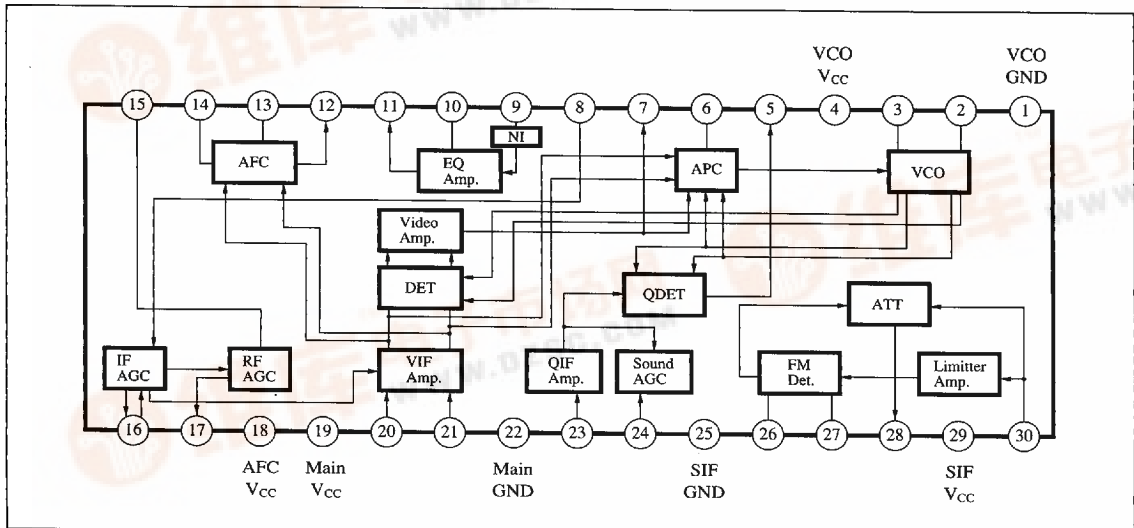

■ Absolute Maximum Ratings (Ta=25°C)

Parameter	Symbol	Rating	Unit
Supply voltage	V _{CC1}	6	V
	V _{CC2}	12.5	
Supply current	I _{CC}	120	mA
Power dissipation (Ta=70°C)	P _D	720	mW
Operating ambient temperature	T _{opr}	-20 to +70	°C
Storage temperature	T _{stg}	-55 to +150	°C

■ Recommended Operating Range (Ta=25°C)

Parameter	Symbol	Range
Supply voltage	V _{CC1}	4.5V to 5.5V
	V _{CC2}	V _{CC1} to 12V

■ Electrical Characteristics (Ta=25°C)

Parameter	Symbol	Condition	min	typ	max	Unit
Video System						
Video detection output	V _{OD}	Typical color signal (white color contained) m=87.5%, V _{in} =80dB μ	1.75	2	2.25	V _{PP}
Synchronous peak voltage	V _p		0.75	0.95	1.15	V
Input sensitivity	V _{SV}	V _{OD} =-3dB	—	52	56	dB μ
Max. allowable input	V _{max. V}		105	110	—	dB μ
Video frequency characteristics (2)	f _{C(2)}	V _{OD} =-3dB	8	10	12	MHz
SN ratio	S/N		50	55	—	dB
Differential gain	DG		—	2	6	%
Differential phase	DP		—	2	5	deg
Inter-modulation	IM		43	49	—	dB
AFC phase detector sensitivity	μ _{APC}	R _L =68k Ω //82k Ω	20	30	40	mV/kHz
APC pull-in range <h>	f _{ph}		1.5	—	—	MHz
APC pull-in range <l>	f _{pl}		—	—	-1.5	MHz
VCO oscillator sensitivity	β	V ₆ =2 to 2.2V	3.5	5.5	7.5	kHz/mV
APC detection sensitivity	μ _{APC}	f _{in} =f ₀ ±500kHz	0.12	0.2	0.3	mV/kHz
Audio System						
QDET output level	V _{QDET}		110	115	120	dB μ
Input sensitivity	V _{SQ}	V _{QDET} =-3dB	—	55	60	dB μ
Max. allowable input	V _{max. Q}		105	110	—	dB μ
Audio detection output	V _{O\otimes}	f ₀ =4.5MHz, V _{in} =100dB μ Δ f=±25kHz, f _m =400Hz	500	630	760	mVrms
Input limiting voltage	V _{i(lim)}	V _{O\otimes} =-3dB	—	48	—	dB μ
AM rejection	AMR	V _{in} =90dB μ	46	60	—	dB
Total harmonics distortion ratio	THD		0	0.3	1	%
Max. attenuation	Att	V _⊗ ≤1.5V	70	—	—	dB
DC Characteristics						
Circuit current Pins ④, ⑱, ⑳	I ₄₊₁₈₊₁₉₊₂₉		55	70	90	mA
Video output pin voltage	V _{I1}		3	3.5	4	V
Audio output pin voltage	V ₂₈		1.1	1.5	1.9	V









■ Pin Descriptions

Pin No.	Symbol	Typ. waveform	Description	I/O impedance	Equivalent circuit
1	GND (VCO)	—	GND pin (VCO system)	—	
2	VCO COIL	—	External pin for VCO-oscillation coil.	—	
3	VCO COIL	—			
4	V _{cc} (VCO)	—	Power supply pin : 5V (VCO System)	—	
5	QDET OUT		Output pin when an audio carrier was detected using the QSS method.	170Ω	
6	APC LPF	—	Pin for external time constant of APC filter.	10kΩ	
7	DET OUT		VIF detection signal output pin.	30Ω	
8	AGC IN		Pin for inputting VIF AGC voltage from the outside.	—	

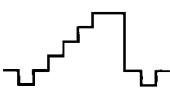
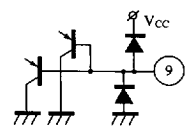
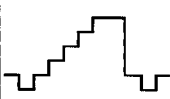
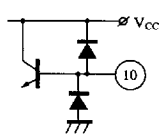
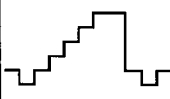
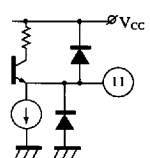
6932852 0014192 359

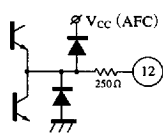

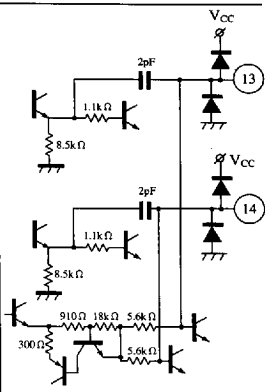
■ Pin Descriptions (cont.)

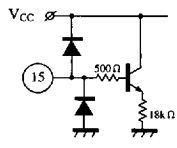
Pin No.	Symbol	Typ. waveform	Description	I/O impedance	Equivalent circuit
9	NI IN		Input pin for noise inverter circuit.	—	
10	FB		Pin for negative feedback circuit of equalizer amp.	—	
11	VOUT		Video signal output pin.	20 Ω	
12	AFC OUT		AFC voltage output pin.	—	
13	AFC COIL		Pin for external AFC coil.	—	
14	AFC COIL				
15	RF AGC ADJ		RF-AGC-setting voltage-adjusting pin.	—	

ICs for TV

6932852 0014193 295

Panasonic

Pin Descriptions (cont.)

Pin No.	Symbol	Typ. waveform	Description	I/O impedance	Equivalent circuit
16	IF AGC	—	Pin for external time constant of VIF AGC filter.	—	
17	RF AGC OUT	—	RF AGC voltage output pin.	—	
18	V _{CC} (AFC)	—	Power supply pin : 5 to 12V (AFC output circuit)	—	
19	V _{CC}	—	Power supply pin : 5V (VIF system)	—	
20	IF IN	<p>Video carrier input pin</p>	Video carrier input pin.	1k Ω	
21	IF IN				
22	GND (VIF)	—	GND pin (VIF system)	—	
23	QIF IN	<p>(FM)</p>	Input pin when an audio carrier is detected using the QSS method.	1k Ω	



■ Pin Descriptions (cont.)

Pin No.	Symbol	Typ. waveform	Description	I/O impedance	Equivalent circuit
24	QAGC	—	Pin for external time constant of audio carrier AGC filter when the QSS method used.	—	
25	GND (SIF)	—	GND pin (SIF system)	—	
26	SIF COIL	—	Pin for external SIF detecting coil.	3.5kΩ	
27	SIF COIL	—		3.5kΩ	
28	SOUT		Audio signal output pin.	200Ω	
29	Vcc (SIF)	—	Power supply pin : 5V (SIF system)	—	
30	SIF IN		SIF signal input pin.	1.8kΩ	

ICs for TV

6932852 0014195 068

Panasonic